

## Index 430-001 Miscellaneous Drainage Details

### Design Criteria

*FDOT Design Manual (FDM); Drainage Manual (DM);*

### Design Assumptions and Limitations

Supplemental Details for use with other Drainage Indexes.

### Plan Content Requirements

Included with other Drainage items.

### Payment

Item number	Item Description	Unit Measure
N/A	Included in other Pay Items	N/A

### Example: Stub Connection Detail

Stub connections require approval of the District Drainage Engineer.

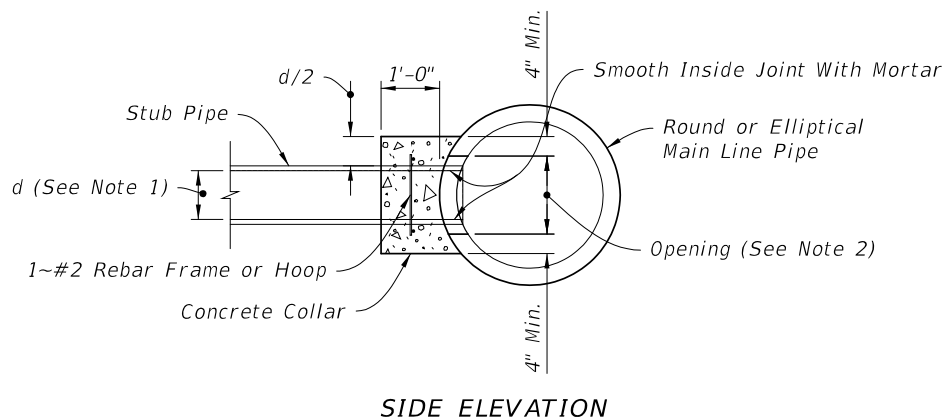
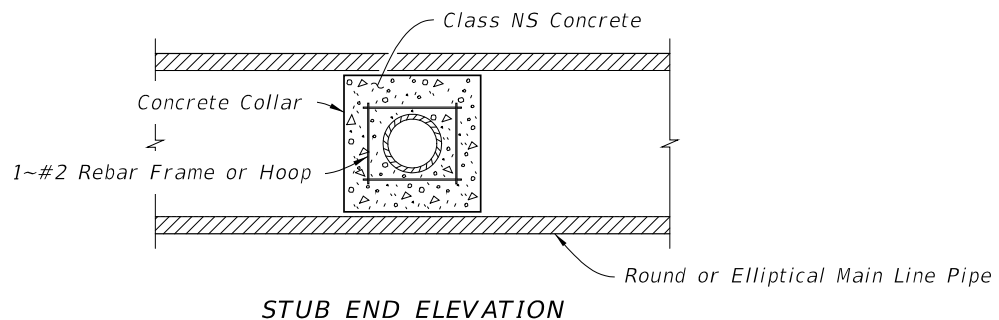

### JOINING MAINLINE PIPE TO STUB PIPE

#### NOTES:

1. Stub Pipes maximum diameter:  $\frac{1}{2}$  of a round main line pipe diameter, or  $\frac{1}{2}$  the height of elliptical main line pipes.
2. Opening by Pipe Manufacturer.