

STEP 1: Calculate the area and the centroid for an individual sign or a sign cluster. Note that the centroid and areas have been calculated for frequently used sign clusters. These are shown on Sheets 7, 8, and 9.

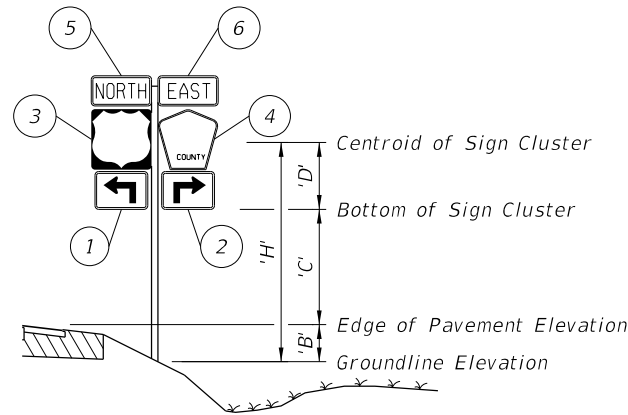

Size a x h	Centroid			'A _n '	'X' _n ' x 'A _n '	'Y' _n ' x 'A _n '
	Local 'Y' _n	Global 'X' _n	Global 'Y' _n			
(in. x in.)	(in.)	(in.)	(in.)	(in. ²)	(in. ³)	(in. ³)
① 21 x 15	7.5	-10.5-1.5-1.5 = -13.5	7.5	315	-4,252.5	2,362.5
② 21 x 15	7.5	10.5+1.5+1.5 = 13.5	7.5	315	+4,252.5	2,362.5
③ 24 x 24	12	-12-1.5 = -13.5	15+1+12 = 28	576	-7,776	16,128
④ 24 x 24	12	12+1.5 = 13.5	15+1+12 = 28	436	5,886	12,208
⑤ 24 x 12	6	-12-1.5 = -13.5	15+1+24+1+6 = 47	288	-3,888	13,536
⑥ 24 x 12	6	12+1.5 = 13.5	15+1+24+1+6 = 47	288	3,888	13,536
TOTALS				2,218	-1,890	60,133

$$\Sigma ('A'_n) = 2,218 \text{ in.}^2 = 15.4 \text{ ft.}^2 \quad \Sigma ('X'_n \times 'A'_n) = -1,890 \text{ in.}^3 = -1.09 \text{ ft.}^3 \quad \Sigma ('Y'_n \times 'A'_n) = 60,133 \text{ in.}^3 = 34.8 \text{ ft.}^3$$

$$'X'_c = \frac{\Sigma ('X'_n \times 'A'_n)}{\Sigma 'A'_n} = -0.1 \text{ ft.} \quad 'Y'_c = \frac{\Sigma ('Y'_n \times 'A'_n)}{\Sigma 'A'_n} = 2.26 \text{ ft.}$$

STEP 2: Determine the height 'H' from groundline to the centroid of the individual sign or sign cluster.

Assume: 'B' = 1 ft., 'C' = 7 ft.
Calculated: X_c' = -0.1 ft., Y_c' = 'D' 2.26 ft.

'H' = 'B' + 'C' + 'D' = 10.26 ft. ==> **USE 11 ft.** Σ ('A_n') = 15.4 ft.² ==> **USE 16 ft.²**

STEP 3: Refer to the Aluminum Column (Post) Selection Tables and find the intersection point. See Sheet 3.

TOTAL PANEL AREA (SF)	'H' (FT)												
	8 ft	9 ft	10 ft	11 ft	12 ft	13 ft	14 ft	15 ft	16 ft	17 ft	18 ft	19 ft	20 ft
3 sf	2	2.5	2.5	2.5	3	3	3	3	3.5	3.5	3.5	3.5	3.5
4 sf	2.5	2.5	3	3	3	3	3.5	3.5	3.5	3.5	3.5	3.5	3.5
5 sf	2.5	3	3	3	3.5	3.5	3.5	3.5	3.5	3.5	3.5	4	4
6 sf	3	3	3.5	3.5	3.5	3.5	3.5	3.5	3.5	3.5	4	4	4
7 sf	3	3.5	3.5	3.5	3.5	3.5	3.5	3.5	4	4	4	4	4
8 sf	3.5	3.5	3.5	3.5	3.5	3.5	3.5	4	4	4	4	4	4
9 sf	3.5	3.5	3.5	3.5	3.5	3.5	4	4	4	4	4	4	4
10 sf	3.5	3.5	3.5	3.5	3.5	4	4	4	4	4	4	4.5	4.5
11 sf	3.5	3.5	3.5	3.5	4	4	4	4	4	4	4	4.5	4.5
12 sf	3.5	3.5	3.5	4	4	4	4	4	4	4	4	4.5	4.5
13 sf	3.5	3.5	4	4	4	4	4	4	4	4	4.5	4.5	5
14 sf	3.5	3.5	4	4	4	4	4	4	4	4.5	4.5	4.5	5
15 sf	3.5	4	4	4	4	4	4	4.5	4.5	4.5	5	5	5
16 sf	3.5	4	4	4	4	4	4	4.5	4.5	5	5	5	6
17 sf	4	4	4	4	4	4	4	4.5	4.5	5	5	5	6
18 sf	4	4	4	4	4	4	4.5	4.5	4.5	5	5	5	6
19 sf	4	4	4	4	4	4	4.5	4.5	4.5	5	5	6	6
20 sf	4	4	4	4	4	4.5	4.5	4.5	5	5	5	6	6
21 sf	4	4	4	4	4.5	4.5	5	5	5	6	6	6	6
22 sf	4	4	4	4.5	4.5	4.5	5	5	6	6	6	6	6
23 sf	4	4	4	4.5	4.5	5	5	5	6	6	6	6	6
24 sf	4	4	4.5	4.5	4.5	5	5	6	6	6	6	6	6
25 sf	4	4	4.5	4.5	5	5	5	6	6	6	6	6	8
26 sf	4	4.5	4.5	4.5	5	5	5	6	6	6	6	8	8
27 sf	4	4.5	4.5	4.5	5	5	6	6	6	6	6	8	8
28 sf	4	4.5	4.5	5	5	5	6	6	6	6	6	8	8
29 sf	4.5	4.5	4.5	5	5	6	6	6	6	6	6	8	8
30 sf	4.5	4.5	5	5	5	6	6	6	6	6	8	8	8

For 'H' = 11 ft., Area = 16 ft.²

- Refer to the Aluminum Column (Post) Selection Table, from Sheet 3 and shown here for reference.

- To determine the required post size, find the intersection of the row labeled "16 SF" and the column labeled "11 FT". For the example the intersection value is "4" (4" OD).

- In the Column (Post) and Foundation Table, the value "4" shows the design requires a 4.0" diameter and 1/4" thick Aluminum Column (Post) and a 2.0' diameter and 3.5' deep Concrete Foundation and 3.0' Stub.

STEP 4: For sign assemblies with signs oriented in two directions, only the sign with the largest area should be analyzed to determine the Column (Post) requirements.

GUIDE TO USE THIS INDEX

SHEET	CONTENTS
1	General Notes and Design Example
2	Design Example - Centroid
3	Column and Foundation Tables
4	Slip Base and Foundation Details
5	Driven Post, Concrete Stub, and Soil Plate Details
6	Wind Beam Connection
7	Wind Beam Connection for Flip Down Sign
8	Slam-Latch Detail
9, 10, & 11	Frequently Used Sign Clusters

GENERAL NOTES:

- Shop Drawings:
This Index is considered fully detailed. Submit Shop Drawings only for minor modifications not detailed in the Plans.
- Aluminum Sign, Wind Beams and Column (Post) Materials:
A. Aluminum Plates: ASTM B209, Alloy 6061-T6
B. Aluminum Bars and Extruded Shapes: ASTM B221, Alloy 6061-T6
C. Aluminum Structural Shapes: ASTM B221 Alloy 6061-T6
D. Cast Aluminum: ASTM B26 Alloy A356-T6
E. Aluminum Weld Material: ER 5556 or 5356
- Galvanized Steel Slip Base Stub Materials:
A. Steel Plate and Structural Shapes: ASTM A36 or ASTM A709, Grade 36
B. Steel Weld Metal: E70XX
- Sign Mounting Bolts, Nuts and Washers:
A. Aluminum Button Head and Flat Head Bolts: ASTM F468 Alloy 2024-T4
B. Aluminum Hex Nuts: ASTM F467 Alloy 6061-T6 or 6262-T9
C. Aluminum Washers: ASTM B221, Alloy 7075-T6
- Stainless Steel Bolts, Nuts and Washers may be used in lieu of the Aluminum button head and flat head bolts as follows:
A. Stainless Steel Bolts: ASTM F593 Alloy Group 2, Condition A, CW1 or SH1
B. Stainless Steel Nuts: ASTM F594
- Sign Column (Post) Bolts, Nuts and Washers:
A. Galvanized U-Bolt (Column): ASTM A449 or ASTM A193 B7 according to ASTM F2329 with double nuts (nut and lock washer optional).
B. Aluminum Bolts (Sleeve): ASTM F468, Alloy 6061-T6 or 2024-T4 with Hex Nuts F467 6061-T6 or 6262-T9 and Washers B221, Al clad 2024-T4
C. Galvanized High Strength Hex Head Bolts (BaseBolts): ASTM F3125, Grade A325, Type 1
D. Galvanized Hex Nuts: ASTM A563 Grade D
E. Galvanized Washers: ASTM F436
F. Galvanized Bolts (Sleeve): ASTM A307 with Galvanized Hex Nuts and Washers
- Coatings:
A. Aluminum Fasteners: Anodic coating (0.0002 inches mint.) and chromate sealed
B. High Strength Steel Bolts Nuts and Washers: ASTM F2329
C. All other steel items (excluding stainless steel): Hot-dip Galvanize-ASTM A123
D. Repair damaged galvanizing in accordance with Specification 562
- BREAKAWAY SUPPORTS REQUIREMENTS: Install non-frangible aluminum column (post) (larger than 3 1/2") with breakaway supports as shown on Sheet 4. Signs shielded by barrier wall or guardrail do not require breakaway support.

GENERAL NOTES AND DESIGN EXAMPLE

6/8/2022 8:32:23 AM

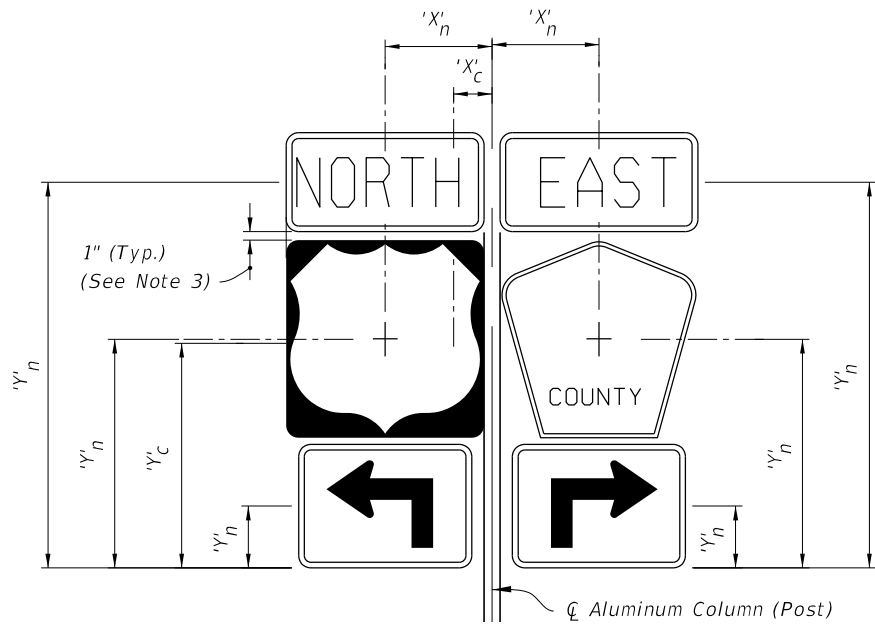

SIGN CLUSTER

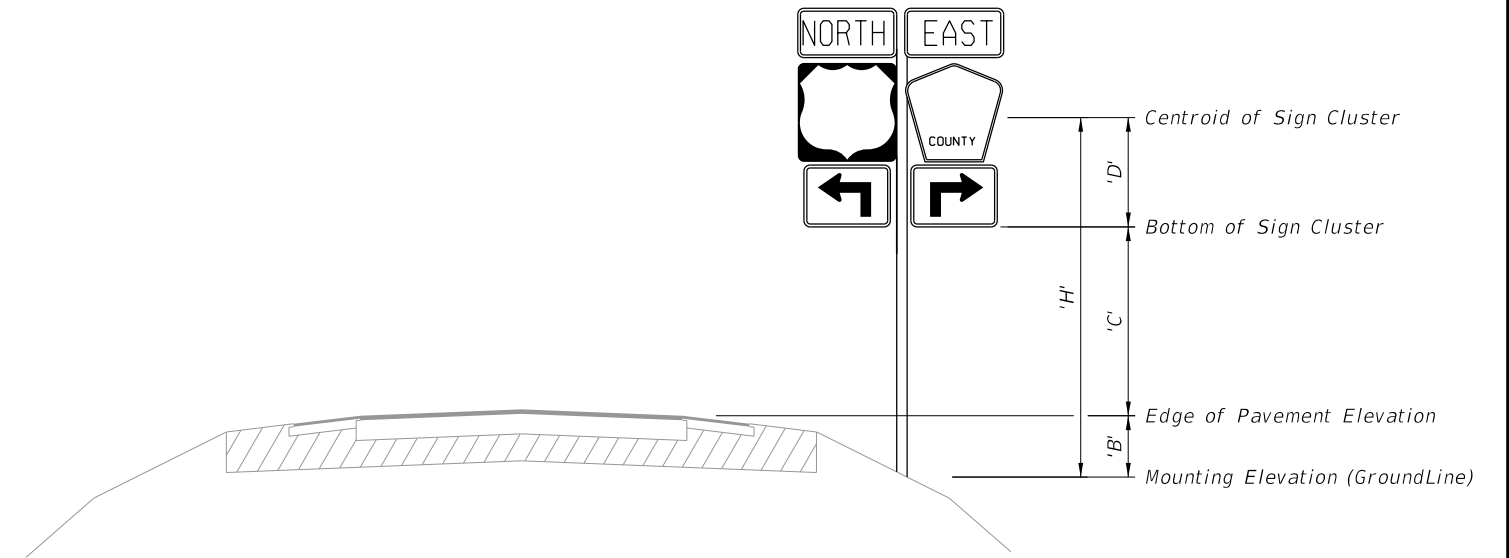

TYPICAL SECTION

$$'X'_c = \frac{\sum ('X'_n \times 'A'_n)}{\sum 'A'_n} \quad 'C' = 'Y'_c = \frac{\sum ('Y'_n \times 'A'_n)}{\sum 'A'_n}$$

- 'A'_n = Area of individual sign
- 'B' = Height of the edge of pavement from the mounting elevation
- 'C' = Height of the the bottom of the sign or cluster from the edge of pavement elevation
- 'D' = Height of the centroid of the sign or cluster from the bottom of the sign or cluster
- h = Individual sign height
- 'H' = Height of sign or cluster centroid from groundline
- a = Individual sign width
- 'X'_c = Centroid horizontal location of sign or cluster from ϕ Aluminum Column (Post)
- 'Y'_c = Centroid height of sign or cluster from bottom of sign cluster
- 'X'_n = Individual sign centroid horizontal location from ϕ Aluminum Column (Post)
- 'Y'_n = Individual Sign centroid height from bottom of sign cluster

NOTES:

1. For 'B' & 'C' see Index 700-101 and Roadway Plans.
2. Do not exceed an area of 30 SF or a width of 60 inches for a sign or a sign cluster, including rotated sign panels.
3. Vertical sign spacing (1" shown on Sign Cluster detail) also applies to rotated signs.

CALCULATION OF SIGN CLUSTER CENTROID

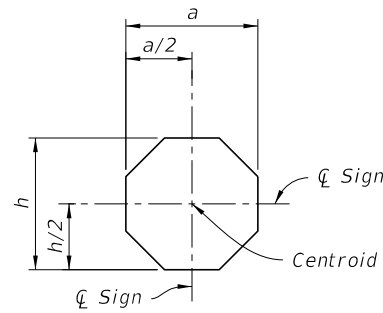

STOP

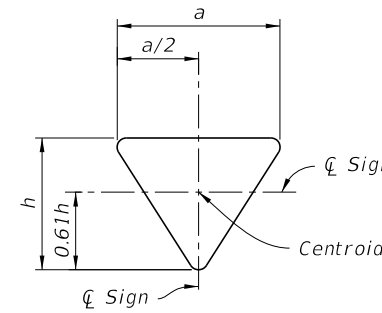

YIELD

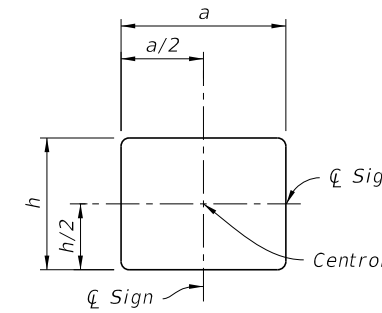

RECTANGLE

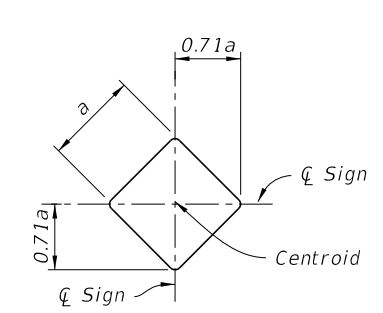

DIAMOND

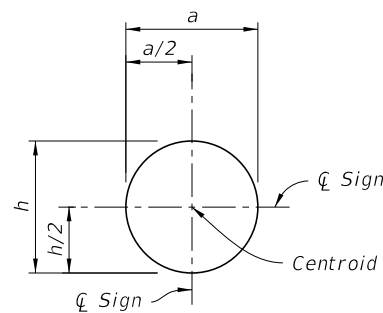

RAILROAD

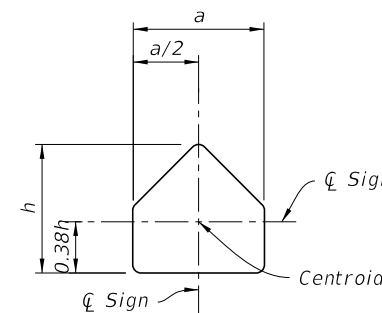

SCHOOL

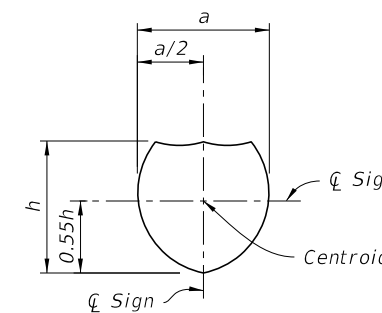

SHIELD

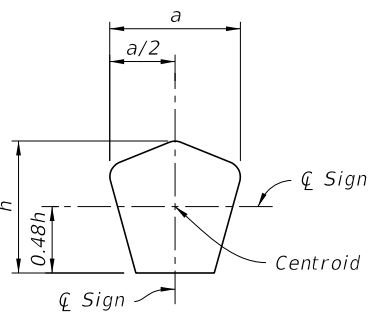

COUNTY

6/8/2022 8:32:26 AM

DESIGN EXAMPLE - CENTROID

LAST REVISION 06/08/22	REVISION	DESCRIPTION: Renumbered Sheet.		FY 2022-23 STANDARD PLANS	SINGLE COLUMN GROUND SIGNS	INDEX 700-010-1	SHEET 2 of 11
---------------------------	----------	-----------------------------------	--	--------------------------------------	-----------------------------------	---------------------------	-------------------------

ALUMINUM COLUMN (POST) SELECTION TABLE (O.D. in.)

TOTAL PANEL AREA (SF)	ALUMINUM COLUMN (POST) SELECTION TABLE (O.D. in.)													
	'H' (FT)													
	8 ft	9 ft	10 ft	11 ft	12 ft	13 ft	14 ft	15 ft	16 ft	17 ft	18 ft	19 ft	20 ft	
3 sf	2	2.5	2.5	2.5	3	3	3	3	3.5	3.5	3.5	3.5	3.5	
4 sf	2.5	2.5	3	3	3	3	3.5	3.5	3.5	3.5	3.5	3.5	3.5	
5 sf	2.5	3	3	3	3.5	3.5	3.5	3.5	3.5	3.5	3.5	4	4	
6 sf	3	3	3.5	3.5	3.5	3.5	3.5	3.5	3.5	3.5	4	4	4	
7 sf	3	3.5	3.5	3.5	3.5	3.5	3.5	3.5	4	4	4	4	4	
8 sf	3.5	3.5	3.5	3.5	3.5	3.5	3.5	4	4	4	4	4	4	
9 sf	3.5	3.5	3.5	3.5	3.5	3.5	4	4	4	4	4	4	4	
10 sf	3.5	3.5	3.5	3.5	3.5	4	4	4	4	4	4	4.5	4.5	
11 sf	3.5	3.5	3.5	3.5	4	4	4	4	4	4	4.5	4.5	4.5	
12 sf	3.5	3.5	3.5	4	4	4	4	4	4	4	4.5	4.5	4.5	
13 sf	3.5	3.5	4	4	4	4	4	4	4	4.5	4.5	4.5	5	
14 sf	3.5	3.5	4	4	4	4	4	4	4.5	4.5	4.5	5	5	
15 sf	3.5	4	4	4	4	4	4	4.5	4.5	4.5	5	5	5	
16 sf	3.5	4	4	4	4	4	4	4.5	4.5	5	5	5	6	
17 sf	4	4	4	4	4	4	4.5	4.5	4.5	5	5	6	6	
18 sf	4	4	4	4	4	4.5	4.5	4.5	5	5	5	6	6	
19 sf	4	4	4	4	4	4.5	4.5	4.5	5	5	6	6	6	
20 sf	4	4	4	4	4.5	4.5	4.5	5	5	5	6	6	6	
21 sf	4	4	4	4	4.5	4.5	5	5	5	6	6	6	6	
22 sf	4	4	4	4.5	4.5	4.5	5	5	6	6	6	6	6	
23 sf	4	4	4	4.5	4.5	5	5	5	6	6	6	6	6	
24 sf	4	4	4.5	4.5	4.5	5	5	6	6	6	6	6	6	
25 sf	4	4	4.5	4.5	5	5	5	6	6	6	6	6	8	
26 sf	4	4.5	4.5	4.5	5	5	5	6	6	6	6	8	8	
27 sf	4	4.5	4.5	4.5	5	5	6	6	6	6	6	8	8	
28 sf	4	4.5	4.5	5	5	5	6	6	6	6	6	8	8	
29 sf	4.5	4.5	4.5	5	5	6	6	6	6	6	6	8	8	
30 sf	4.5	4.5	5	5	5	6	6	6	6	6	6	8	8	

FOUNDATION TABLE

Column (Post) Size		Foundation Alternatives				
		Driven Post *		Concrete (Class II)		
Outside Diameter (in)	Wall Thk. (in)	Embedment Depth (ft)		Diameter (ft)	Embedment Depth (ft)	Stub Length (ft)
		without Soil Plate	with Soil Plate			
2.0	1/8	4.5	2.5	---	---	---
2.5	1/8	5.0	3.0	---	---	---
3.0	1/8	5.0	3.5	---	---	---
3.5	3/16	6.0	4.5	---	---	---
4.0	1/4	---	---	2.0	3.5	3.0
4.5	1/4	---	---	2.0	4.0	3.0
5.0	1/4	---	---	2.0	4.5	3.0
6.0	1/4	---	---	2.0	5.0	3.0
8.0	1/4	---	---	2.0	5.5	3.0

* INSTALLING FRANGIBLE COLUMN SUPPORTS:

Columns (posts) 3 1/2" O.D. and less are considered frangible and may be installed either by driving the post or setting the posts in preformed holes. Backfill preformed holes with suitable material tamped in layers not thicker than 6" (to provide adequate compaction) or filled with flowable fill or bagged concrete.

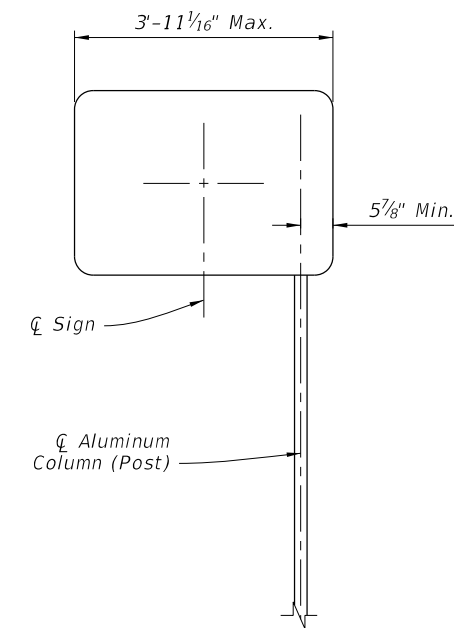

OFFSET SIGN

NOTES:

1. For offset sign placement see Index 700-101.
2. For signs with widths greater than 4' see Index 700-011.
3. Offset signs with driven posts require a soil plate.

COLUMN AND FOUNDATION TABLES

6/8/2022 8:32:27 AM

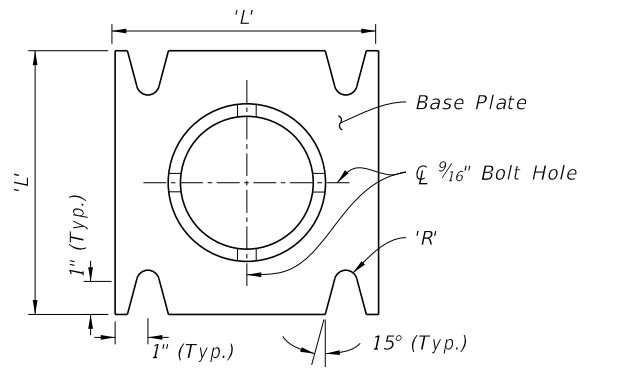
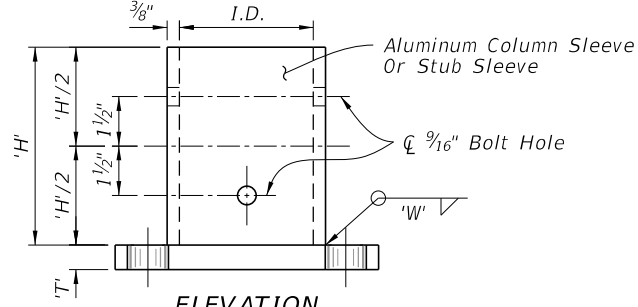

STUB/SLEEVE & BASE PLATE DETAILS
(Welded Or Sandcast)

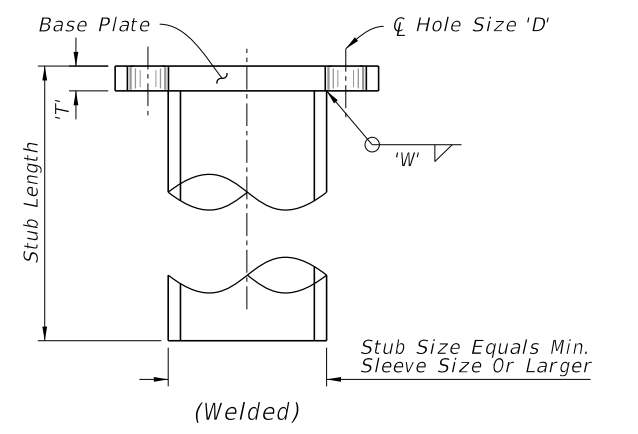

STUB DETAIL

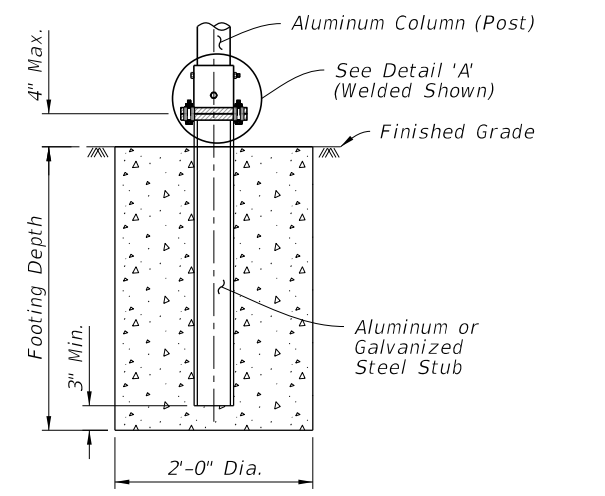

SLIP BASE AND FOUNDATION DETAIL
(Non-Frangible Column, Typ.)

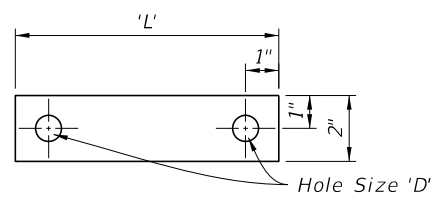

28 Ga. Thick Aluminum Strip
2 Req. Per Base
BOLT KEEPER PLATE DETAIL

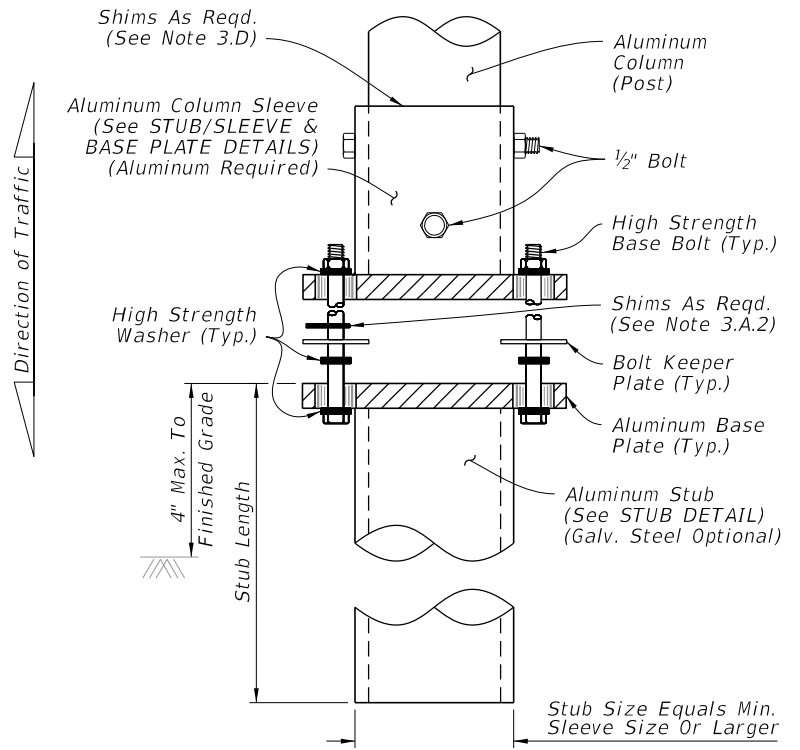

WELDED STUB BASE

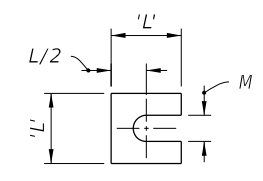

Provide 2~0.0149" Thick (28 gauge)
and 2~0.0329" Thick (21 gauge)
Brass Shims Per Post
SHIM DETAIL

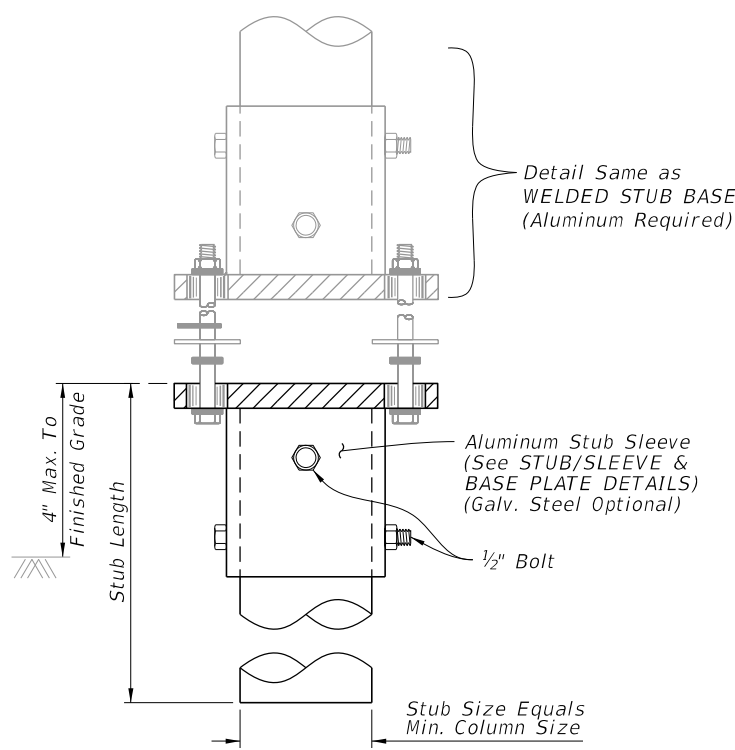

BOLTED STUB/SLEEVE BASE

DETAIL 'A'

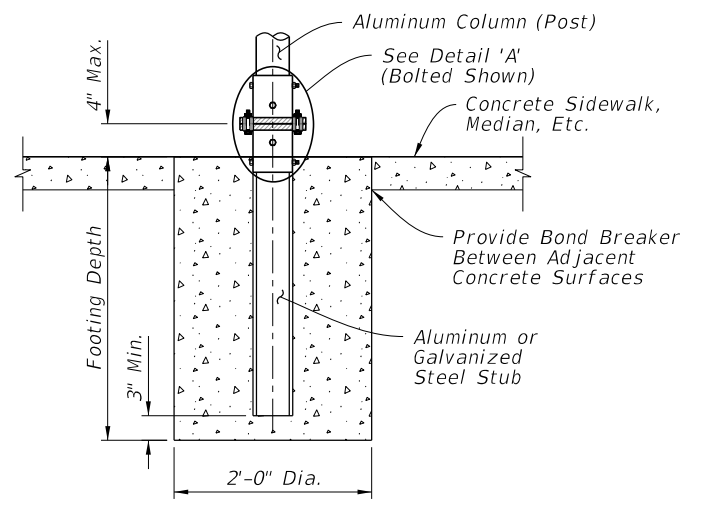

SLIP BASE AND FOUNDATION DETAIL IN CONCRETE
(Non-Frangible Column In Crossovers, Medians & Sidewalks)

NOTES:

- Foundation Notes for Slip Base:**
 - Place Stub into concrete foundation given in the FOUNDATION TABLE using Class II Concrete.
- Slip Base Fabrication Notes:**
 - The difference between the O.D. of the post and I.D. of the Sleeve must be 1/16" or less.
 - The WELDED STUB BASE and lower STUB/SLEEVE BASE PLATE may be fabricated using galvanized steel as an option to aluminum. The upper portion of the SLIP BASE must be aluminum.
 - Either a Welded Stub Base or Bolted Stub/Sleeve Base may be used in Slip Base.
 - For cast base plates bolted to foundation stubs, use a foundation stub the same size as the sign column (Post).
- Slip-Base Assembly Instructions:**
 - Assemble the Slip Base as follows:
 - Insert Post into Sleeve and connect using 2 ~ 1/2" diameter Sleeve Bolts.
 - Assemble top base plate to bottom Base Plate using Base Bolts (High strength) with 3 washers per bolt. (See Detail 'A'):
 - Place one washer on each Base Bolt between the bottom Base Plate and the Base Bolt head.
 - Place the next washer between the Bottom Base Plate and the Bolt Keeper Plate.
 - Use brass or galvanized steel shims to plumb the post.
 - Add the top base plate section.
 - Place the third washer between the Top Base Plate and the Nut.
 - Orient the Bolt Keeper Plates in the Direction of Traffic.
 - Tighten Base Bolts as follows:
 - Tighten Base Bolts to the maximum possible with a 12" to 15" wrench (this will bed the washers and shims and clear the bolt threads).
 - Loosen each Base Bolt one turn.
 - Under the supervision of the Engineer, use a calibrated wrench to tighten bolts to the torque prescribed in the SLIP BASE DETAILS Table. Over tightened Base Bolts are not permitted.
 - Distort bolt threads at the junction with nuts to prevent loosening. Repair damaged galvanizing.
 - Obtain a tight sleeve connection by placing 4 galvanized steel shims between the column (post) and sleeve. Space the shims evenly around the perimeter of the column (1 between each bolt hole, 4 total). Use shims that are 1" shorter than the height of the sleeve.

Column (Post) Size		SLIP BASE DETAILS												
Outside Dia.	Wall Thickness	Sleeve I.D. (Max.)	Sleeve Height 'H'	Weld 'W'	Base Plate		Radius 'R'	Base Bolt Size	Base Bolt Length	Base Plate Torque		Hole Size 'D'	SHIM	
					'L'	'T'				ft.-lbs	in.-lbs		L	M
4"	1/4"	4 1/16"	6"	1/4"	8"	3/4"	1 1/32"	5/8"	3"	29	345	1 1/16"	1 3/8"	1 1/16"
4 1/2"	1/4"	4 9/16"	6"	1/4"	8"	7/8"	1 1/32"	5/8"	3 1/4"	29	345	1 1/16"	1 3/8"	1 1/16"
5"	1/4"	5 1/16"	7"	1/4"	8"	7/8"	1 1/32"	5/8"	3 1/4"	29	345	1 1/16"	1 3/8"	1 1/16"
6"	1/4"	6 1/16"	8"	1/4"	9"	1"	1 3/32"	3/4"	3 1/2"	46	554	1 3/16"	1 3/4"	1 3/16"
8"	1/4"	8 1/16"	10"	1/4"	11"	1"	1 5/32"	7/8"	3 3/4"	53	640	1 5/16"	2 3/8"	1 1/16"

SLIP BASE AND FOUNDATION DETAILS

6/6/2022 8:32:28 AM

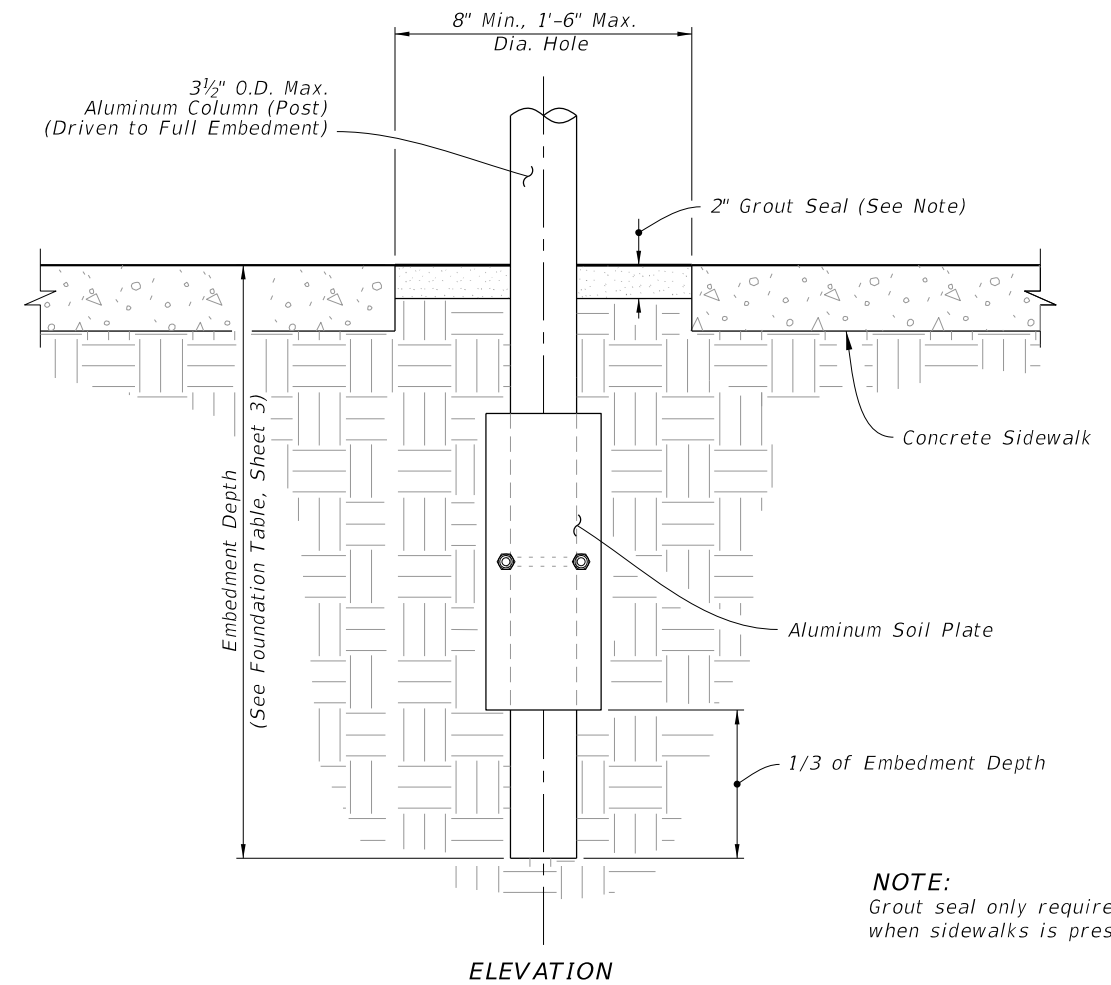
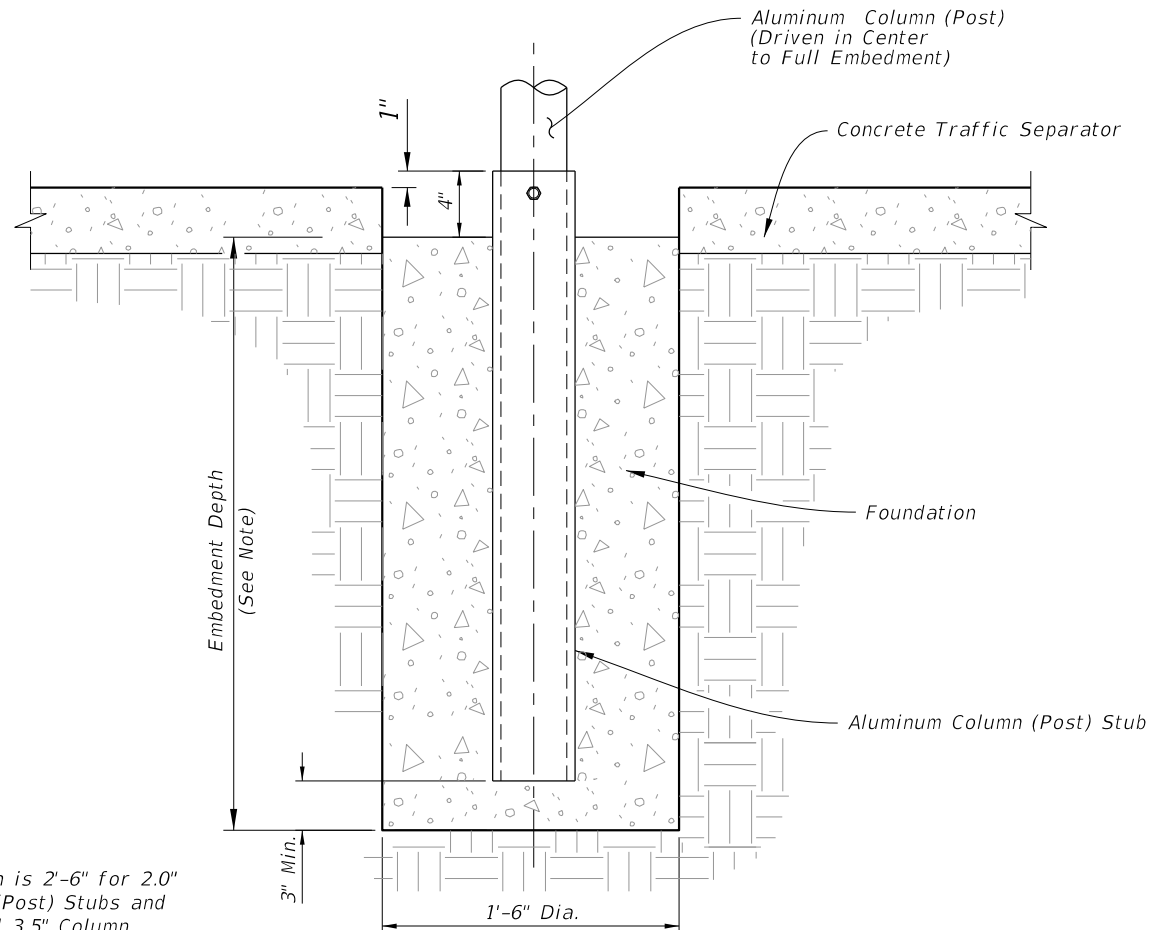
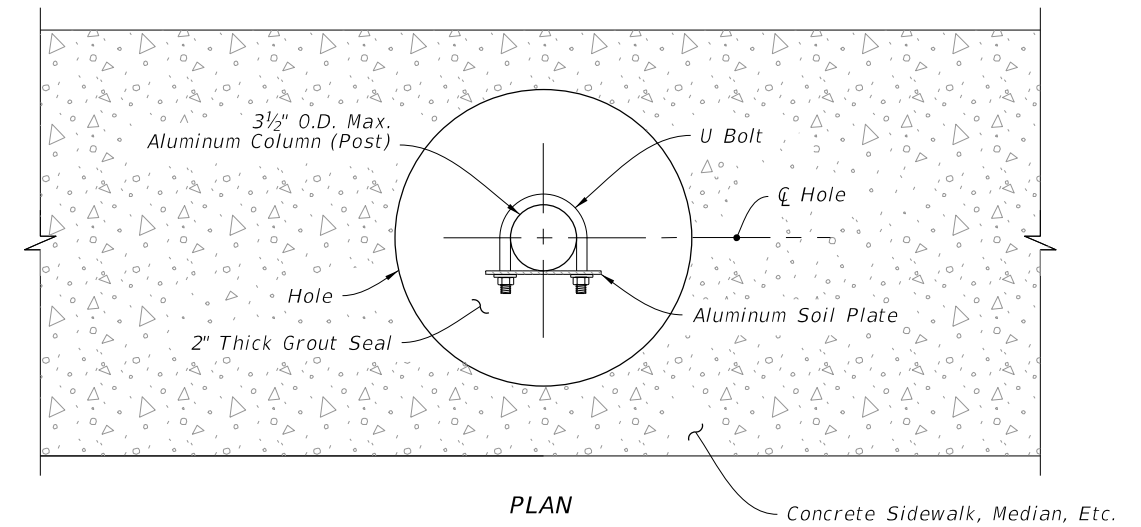
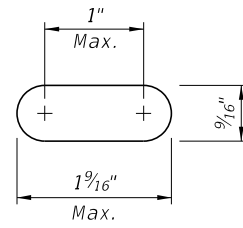
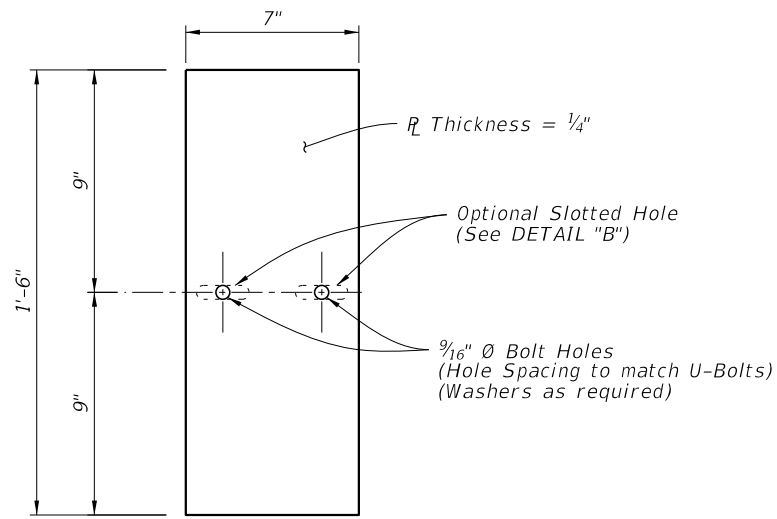

NOTE:
Embedment Depth is 2'-6" for 2.0" and 2.5" Column (Post) Stubs and 3'-6" for 3.0" and 3.5" Column (Post) Stubs.

NOTE:
Grout seal only required when sidewalks is present.

6/8/2022 8:32:29 AM

LAST REVISION 06/08/22	DESCRIPTION: Renumbered Sheet.
---------------------------	-----------------------------------



FY 2022-23
STANDARD PLANS

SINGLE COLUMN GROUND SIGNS

INDEX
700-010-1

SHEET
5 of 11

DRIVEN POST, CONCRETE/STUB, AND SOIL PLATE DETAILS

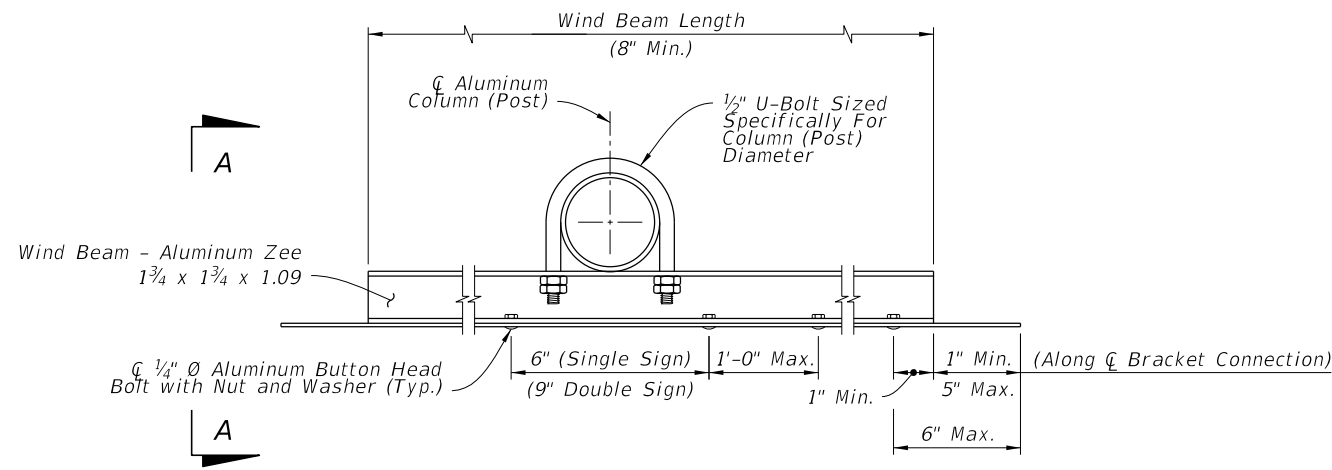

NOTES:

1. $\frac{5}{16}$ " \emptyset stainless steel hex head bolts with nylon washer under head and washer under nut may be used in lieu of $\frac{1}{4}$ " \emptyset aluminum button or flat head bolts.
2. Use nylon washers (provided by the sheeting supplier) under the bolt heads to protect sign sheeting.
3. Slots up to 2" long are allowed in wind beams to accommodate U-Bolts for varying Column (Post) diameters.
4. Wind beams may be oriented in either direction.
5. For signs greater than 66" in height, install a third wind beam evenly spaced between the top and bottom wind beams. For signs up to 12" in height, use only one wind beam at \emptyset Sign. Install two wind beams on signs with heights greater than 12" and less than or equal to 66".

WIND BEAM CONNECTIONS DETAILS

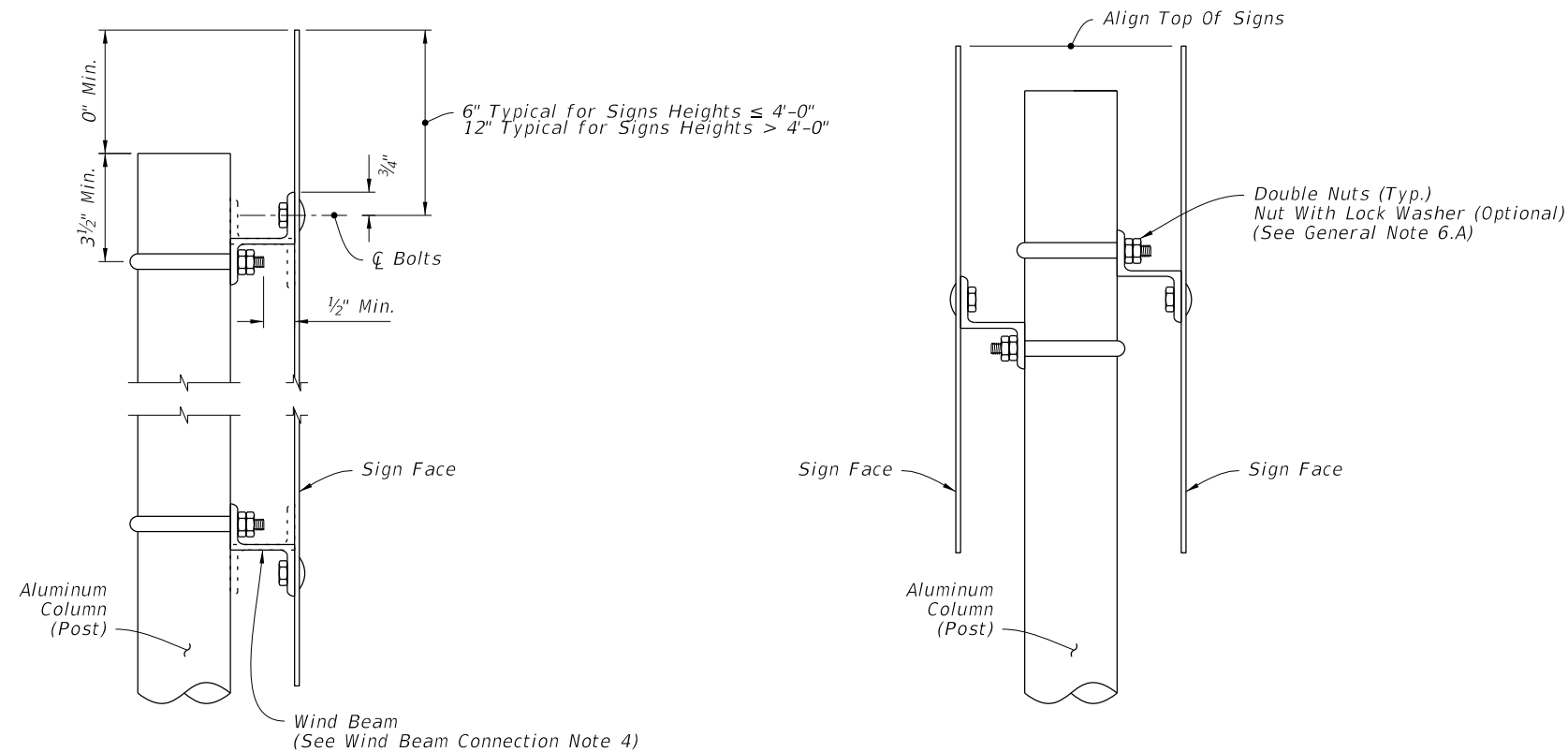

NOTE: Use the area and the centroid location of the largest sign to determine aluminum column (post) size.

SINGLE SIGN DETAIL

BACK-TO-BACK SIGN DETAIL

VIEW A-A

8:32:29 AM
6/6/2022

WIND BEAM CONNECTION

LAST REVISION 06/08/22	REVISION	DESCRIPTION: Renumbered Sheet.		FY 2022-23 STANDARD PLANS	SINGLE COLUMN GROUND SIGNS	INDEX 700-010-1	SHEET 6 of 11
---------------------------	----------	-----------------------------------	--	------------------------------	----------------------------	--------------------	------------------

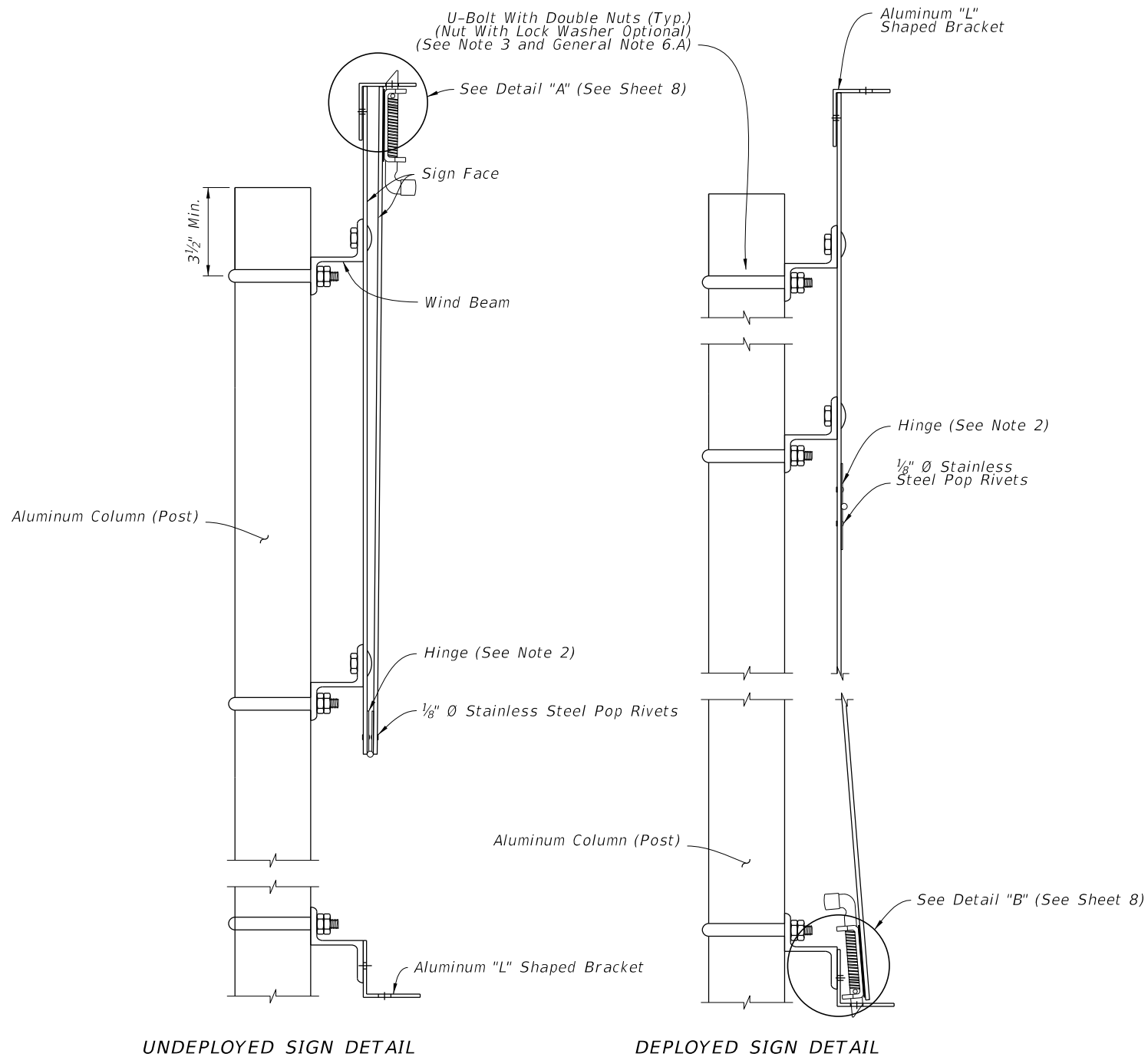

UNDEPLOYED SIGN DETAIL

DEPLOYED SIGN DETAIL

SIGN PANEL SIDE VIEW

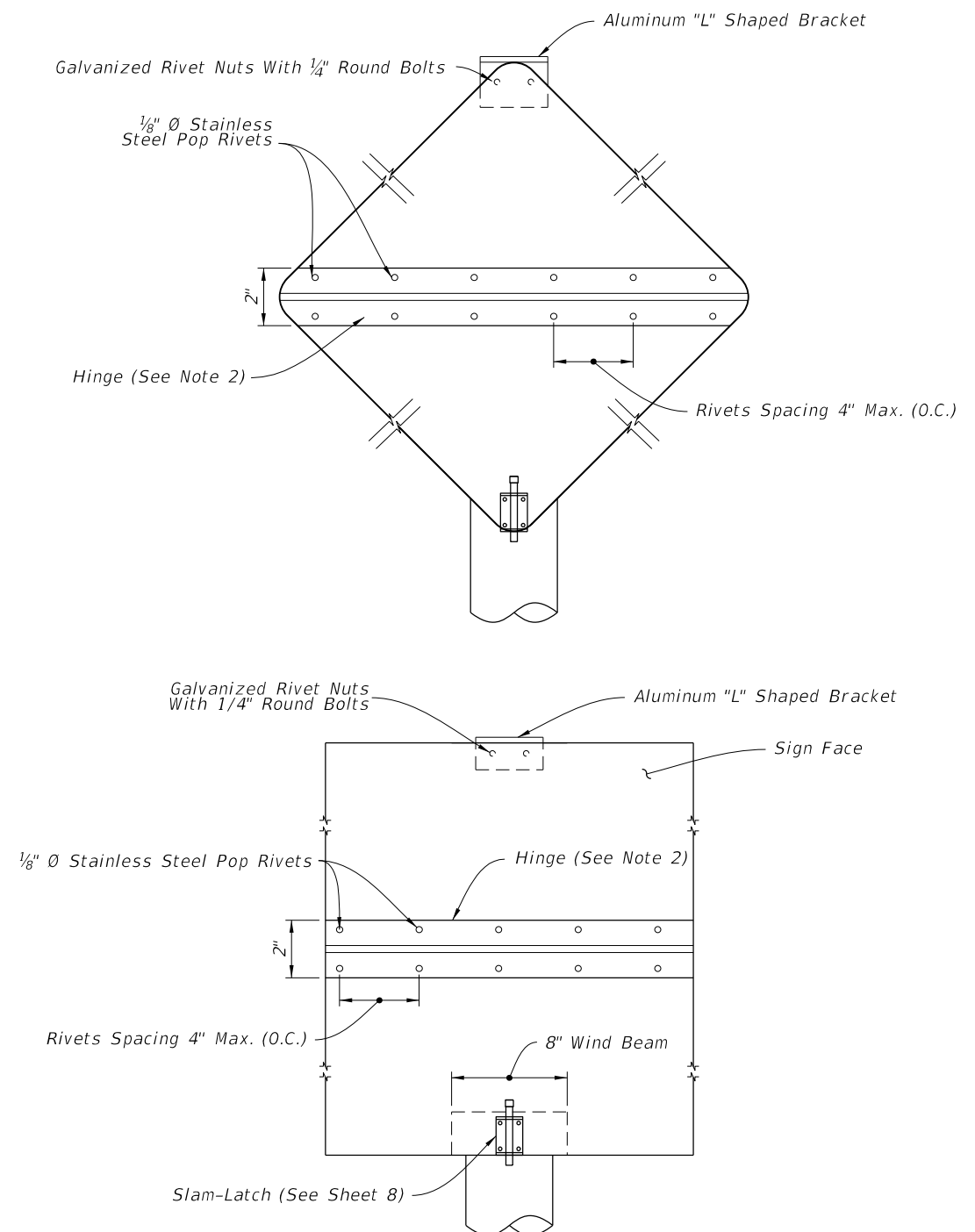

SIGN PANEL FRONT VIEW

NOTES:

1. Install sign in the undeployed (up) position.
2. Provide a continuous stainless steel hinge with minimum 0.060" leaf thickness, 2" open width and 0.120" pin diameter. Stake the hinge at both ends to prevent pin movement.
3. Install Stainless Steel Spring Loaded Slam-Latch with cover to bottom face of flip sign per manufacturer's recommendations.
4. Punch or drill a 3/4" diameter hole in the "L" shaped bracket on site to match location of 1/2" wide slam-latch pin. Remove any burrs or sharp edges.

WIND BEAM CONNECTION FOR FLIP DOWN SIGN

6/8/2022 8:32:30 AM

LAST REVISION 06/08/22	DESCRIPTION: Added new "Wind Beam Connection For Flip Down Sign", detailing the Spring Slam-Latch.	 FY 2022-23 STANDARD PLANS	SINGLE COLUMN GROUND SIGNS	INDEX 700-010-1	SHEET 7 of 11
---------------------------	---	---	----------------------------	--------------------	------------------

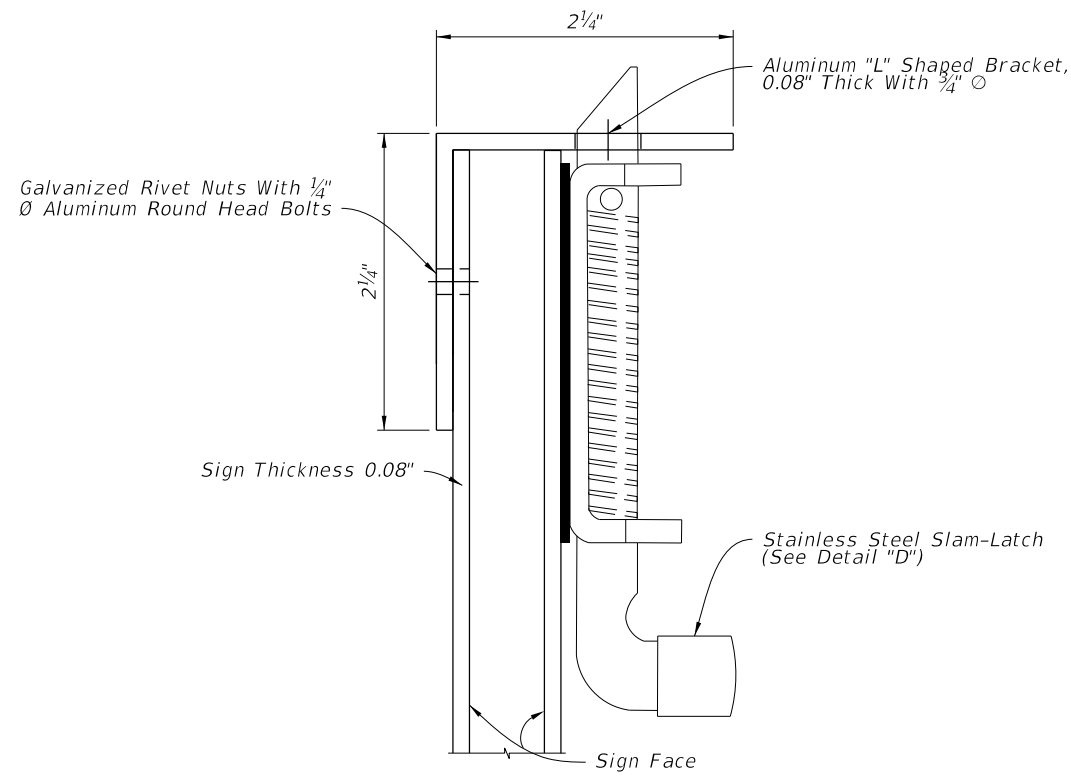

DETAIL "A"

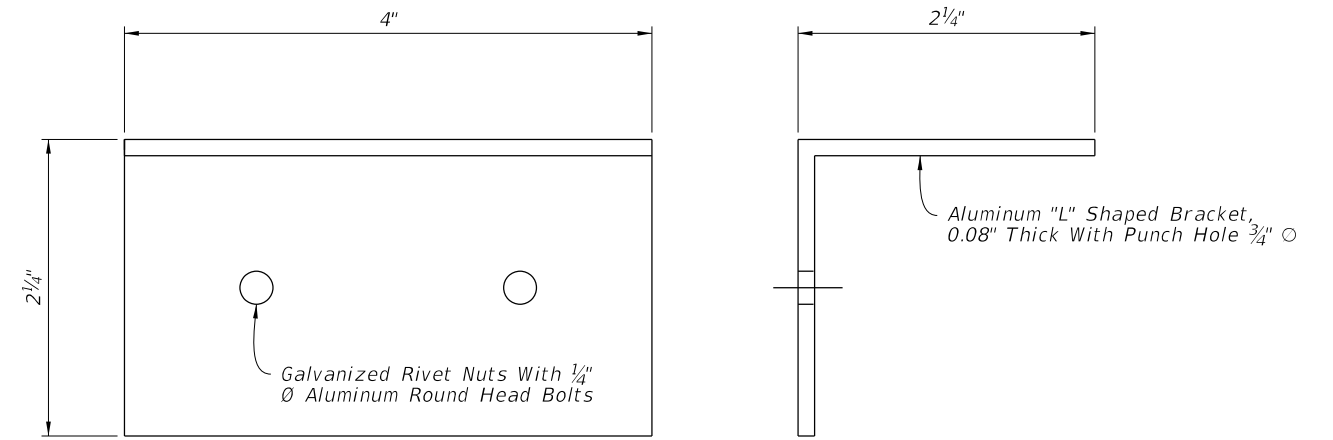

"L" Shaped Bracket

DETAIL "C"

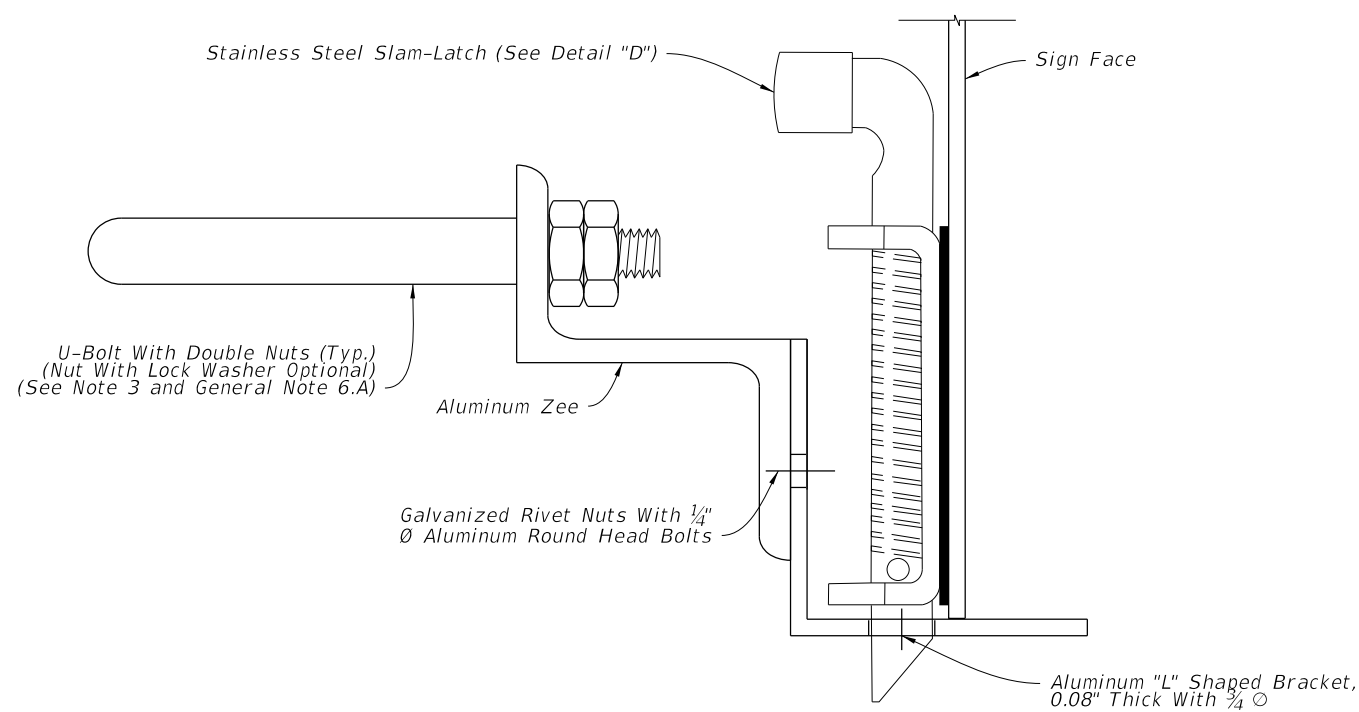

DETAIL "B"

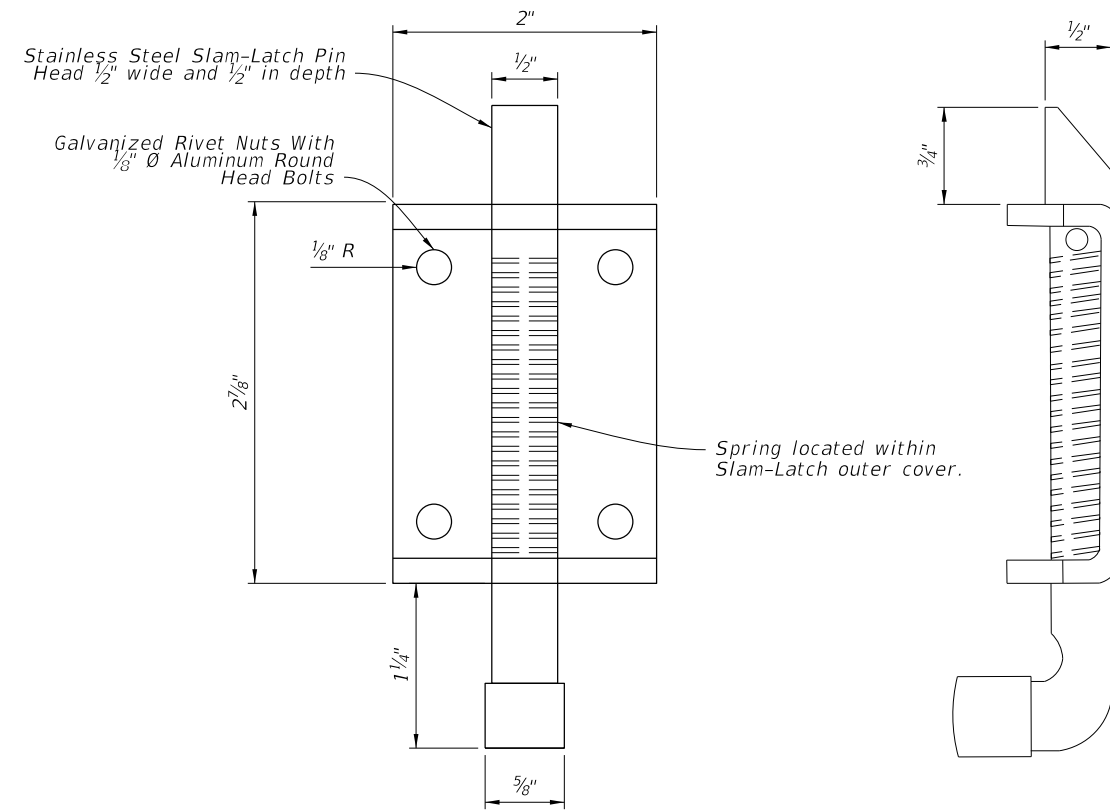

Stainless Steel Slam-Latch

DETAIL "D"

SLAM-LATCH DETAIL

6/6/2022 8:32:31 AM

<p>LAST REVISION 06/08/22</p>	<p>REVISION</p> <p>DESCRIPTION: Added new sheet showing the Spring Slam-Latch details.</p>	 <p>FY 2022-23 STANDARD PLANS</p>	<p>SINGLE COLUMN GROUND SIGNS</p>	<p>INDEX 700-010-1</p>	<p>SHEET 8 of 11</p>
-----------------------------------	--	--	-----------------------------------	----------------------------	--------------------------

6/8/2022 8:32:32 AM

	Size	Area	Total Area	Centroid
	36x12	3.00 SF	6.31 SF	1.75 Ft.
	24x24	3.31 SF		
	36x12	3.00 SF	8.18 SF	1.92 Ft.
	30x30	5.18 SF		
	36x12	3.00 SF	10.46 SF	2.10 Ft.
	36x36	7.46 SF		
	36x12	3.00 SF	16.25 SF	2.48 Ft.
	48x48	13.25 SF		
	24x24	3.31 SF	6.31 SF	1.71 Ft.
	24x18	3.00 SF		
	30x30	5.18 SF	10.18 SF	2.19 Ft.
	30x24	5.00 SF		
	36x36	7.46 SF	12.46 SF	2.55 Ft.
	30x24	5.00 SF		

	Size	Area	Total Area	Centroid
	36x12	3.00 SF	13.18 SF	2.87 Ft.
	30x30	5.18 SF		
	30x24	5.00 SF	15.46 SF	3.15 Ft.
	36x36	7.46 SF		
	36x12	3.00 SF	30x24	5.00 SF
	36x36	7.46 SF		
	21x15	2.19 SF	6.19 SF	1.60 Ft.
	24x24	4.00 SF		
	21x15	2.19 SF	7.19 SF	1.52 Ft.
	30x24	5.00 SF		
	24x12	2.00 SF	6.00 SF	1.53 Ft.
	24x24	4.00 SF		
	24x12	2.00 SF	7.00 SF	1.45 Ft.
	30x24	5.00 SF		
	30x15	3.13 SF	8.13 SF	1.66 Ft.
	30x24	5.00 SF		

	Size	Area	Total Area	Centroid
	24x24	4.00 SF	6.19 SF	1.73 Ft.
	21x15	2.19 SF		
	30x24	5.00 SF	7.19 SF	1.81 Ft.
	21x15	2.19 SF		
	24x12	2.00 SF	8.19 SF	2.26 Ft.
	24x24	4.00 SF		
	24x12	2.00 SF	9.19 SF	2.27 Ft.
	30x24	5.00 SF		
	30x15	3.13 SF	10.32 SF	2.49 Ft.
	30x24	5.00 SF		
	24x12	2.00 SF	10.19 SF	2.80 Ft.
	24x12	2.00 SF		
	24x24	4.00 SF	8.13 SF	1.66 Ft.
	21x15	2.19 SF		

LAST REVISION 06/08/22

DESCRIPTION: Renumbered Sheet.







FY 2022-23 STANDARD PLANS





SINGLE COLUMN GROUND SIGNS

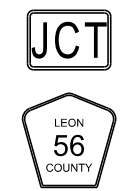
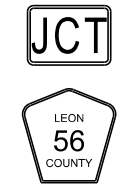

INDEX 700-010-1

SHEET 9 of 11

6/8/2022 8:32:33 AM

	Size	Area	Total Area	Centroid
	24x12	2.00 SF	11.19 SF	2.76 Ft.
	24x12	2.00 SF		
	30x24	5.00 SF		
	21x15	2.19 SF		
	Size	Area	Total Area	Centroid
	30x15	3.13 SF	13.45 SF	3.16 Ft.
	30x15	3.13 SF		
	30x24	5.00 SF		
	21x15	2.19 SF		
	Size	Area	Total Area	Centroid
	21x15	2.19 SF	3.90 SF	1.57 Ft.
	18x18	1.71 SF		
	Size	Area	Total Area	Centroid
	21x15	2.19 SF	5.22 SF	1.72 Ft.
	24x24	3.03 SF		
	Size	Area	Total Area	Centroid
	21x15	2.19 SF	6.95 SF	1.87 Ft.
	30x30	4.76 SF		

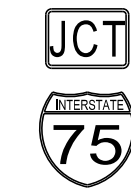
	Size	Area	Total Area	Centroid
	18x18	1.71 SF	3.90 SF	1.26 Ft.
	21x15	2.19 SF		
	Size	Area	Total Area	Centroid
	24x24	3.03 SF	5.22 SF	1.62 Ft.
	21x15	2.19 SF		
	Size	Area	Total Area	Centroid
	30x30	4.76 SF	6.95 SF	1.97 Ft.
	21x15	2.19 SF		
	Size	Area	Total Area	Centroid
	24x12	2.00 SF	9.39 SF	2.87 Ft.
	24x12	2.00 SF		
	24x24	3.20 SF		
	21x15	2.19 SF		
	Size	Area	Total Area	Centroid
	24x12	2.00 SF	10.18 SF	2.84 Ft.
	24x12	2.00 SF		
	30x24	3.99 SF		
	21x15	2.19 SF		

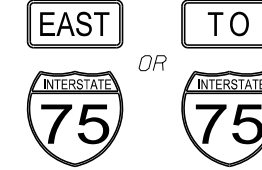
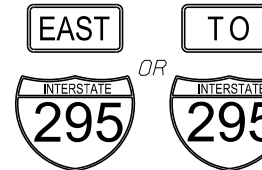
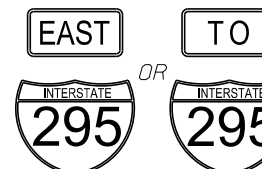
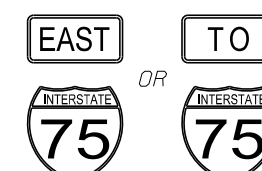
	Size	Area	Total Area	Centroid
	30x15	3.13 SF	12.44 SF	3.26 Ft.
	30x15	3.13 SF		
	30x24	3.99 SF		
	21x15	2.19 SF		
	Size	Area	Total Area	Centroid
	21x15	2.19 SF	5.39 SF	1.75 Ft.
	24x24	3.20 SF		
	Size	Area	Total Area	Centroid
	21x15	2.19 SF	6.18 SF	1.67 Ft.
	30x24	3.99 SF		
	Size	Area	Total Area	Centroid
	24x12	2.00 SF	5.20 SF	1.67 Ft.
	24x24	3.20 SF		
	Size	Area	Total Area	Centroid
	24x12	2.00 SF	5.99 SF	1.60 Ft.
	30x24	3.99 SF		
	Size	Area	Total Area	Centroid
	30x15	3.13 SF	7.12 SF	1.81 Ft.
	30x24	3.99 SF		
	Size	Area	Total Area	Centroid
	30x15	3.13 SF	10.33 SF	2.27 Ft.
	36x36	7.20 SF		

LAST REVISION 06/08/22

DESCRIPTION: Renumbered Sheet.



FY 2022-23 STANDARD PLANS

SINGLE COLUMN GROUND SIGNS

INDEX 700-010-1

SHEET 10 of 11

6/8/2022 8:32:33 AM

Size	Area	Total Area	Centroid
30x15	3.13 SF	12.12 SF	2.18 Ft.
45x36	8.99 SF		
24x12	2.00 SF	7.39 SF	2.30 Ft.
24x24	3.20 SF		
21x15	2.19 SF		
24x12	2.00 SF	8.18 SF	2.31 Ft.
30x24	3.99 SF		
21x15	2.19 SF		
30x15	3.13 SF	9.31 SF	2.55 Ft.
30x24	3.99 SF		
21x15	2.19 SF		
30x30	4.69 SF	6.69 SF	1.61 Ft.
24x12	2.00 SF		
30x30	4.69 SF	8.44 SF	1.77 Ft.
30x18	3.75 SF		
36x36	6.75 SF	10.50 SF	2.06 Ft.
30x18	3.75 SF		
30x30	4.69 SF	12.75 SF	2.84 Ft.
30x18	3.75 SF		
30x30	4.69 SF	10.25 SF	2.74 Ft.
24x24	4.00 SF		
36x36	6.75 SF	15.25 SF	3.29 Ft.
30x30	6.25 SF		

Size	Area	Total Area	Centroid
30X30	4.69 SF	6.69 SF	1.61 Ft.
24X12	2.00 SF		
30X30	4.69 SF	8.44 SF	1.77 Ft.
30X18	3.75 SF		
36X36	6.75 SF	10.50 SF	2.06 Ft.
30X18	3.75 SF		
30X30	6.25 SF	8.25 SF	2.28 Ft.
24X12	2.00 SF		
36X36	9.00 SF	12.75 SF	2.84 Ft.
30X18	3.75 SF		
30X30	6.25 SF	10.25 SF	2.74 Ft.
24X24	4.00 SF		
36X36	9.00 SF	15.25 SF	3.29 Ft.
30X30	6.25 SF		

Size	Area	Total Area	Centroid
30X30	6.25 SF	9.25 SF	2.51 Ft.
24X18	3.00 SF		
36X36	9.00 SF	14.00 SF	3.06 Ft.
30X24	5.00 SF		

LAST REVISION 06/08/22

DESCRIPTION: Renumbered Sheet.



FY 2022-23
STANDARD PLANS

SINGLE COLUMN GROUND SIGNS

INDEX
700-010-1

SHEET
11 of 11