

GENERAL NOTES:

1. LUMINAIRE LOAD: Poles are designed to support the following:
 - A. Luminaire Effective Projected Area (EPA): 1.55 SF
 - B. Luminaire Weight: 75 lb.
2. SHOP DRAWINGS: This Index is considered fully detailed; only submit shop drawings for minor modifications not included in the Plans.
3. MATERIALS:
 - A. Pole, Arm Tubes, Strut Tubes, Bars, Plates, Stiffeners: ASTM B221, Alloy 6063-T6 or Alloy 6061-T6
 - B. Pole Connection Extrusion Clamp: ASTM B221, Alloy 6061-T6
 - C. Caps and Covers: ASTM B-26, Alloy 319-F
 - D. Aluminum Weld Material: ER 4043
 - E. Transformer and Frangible Base Materials: ASTM B26 or ASTM B108, Alloy 356-T6
 - F. Base Bolts, Nuts and Washers:
 - a. Shoe Base Bolts: ASTM F3125, Grade A325, Type 1
 - b. Nuts: ASTM A563 Grade DH Heavy-Hex
 - c. Washer: ASTM F436 Type 1
 - G. Anchor Bolts, Nuts, and Washers:
 - a. Anchor Bolts: ASTM F1554 Grade 55
 - b. Nuts: ASTM A563 Grade A Heavy-Hex
 - H. Clamp Hardware: See Sheet 2
 - I. Stainless Steel Cap Fasteners: ASTM F593 Alloy Group 2, Condition A, CW1 or SH1
 - J. Nut Covers: ASTM B26 (319-F)
 - K. Concrete: Class II
 - L. Reinforcing Steel: Specification 415
4. FABRICATION:
 - A. Weld Arm and Pole Alloy in the T4 temper using 4043 filler. Age the Arm and Pole artificially to the T6 temper after welding.
 - B. Transverse welds are only allowed at the base.
 - C. Light Pole Properties: Taper as required to provide a round top O.D. of 8" and a base O.D. of 10" for all pole heights. Portions of the pole near the base shoe and at the arm connections may be held constant to simplify fabrication. Maintain pole wall thickness of 0.313" Min.
 - D. Fixture Arm Tube Properties: See Sheet 2.
 - E. Provide 'J', 'S' or 'C' hook at top of pole for electrical wires.
 - F. Perform all welding in accordance with AWS D1.2.
 - G. Identification Tag: (Submit details for approval.)
 - a. 2" x 4" (Max.) aluminum identification tag.
 - b. Locate on the inside of the transformer base and visible from the door opening.
 - c. Secure to transformer base with 1/8" diameter stainless steel rivets or screws.
 - d. Include the following information on the ID Tag:
 1. Financial Project ID
 2. Pole Height
 3. Manufacturer's Name
5. COATINGS/FINISH:
 - A. Pole and Arm Finish: 50 grit satin rubbed.
 - B. Galvanize Steel Bolts, Screws, Nuts and Washers: ASTM F2329
 - C. Hot Dip Galvanize miscellaneous steel items: ASTM A123
6. CONSTRUCTION:
 - A. Foundation: Specification 455, except payment for the foundation is included in the cost of the pole.
 - B. Frangible Base, Base Shoe, and Pole Connection Extrusion Clamp:
 - a. Certify that the Pole Connection Extrusion Clamp, Frangible Transformer Base, and Base Shoe Design are capable of providing the required capacity, assuming a design wind speed of 160 MPH.
 - b. Certify the Base conforms to the FHWA required AASHTO Frangibility Requirements, tested under NCHRP Report 350 Guidelines (e.g. Akron Foundry TB1-17).
 - c. Do not erect pole without Luminaire attached.

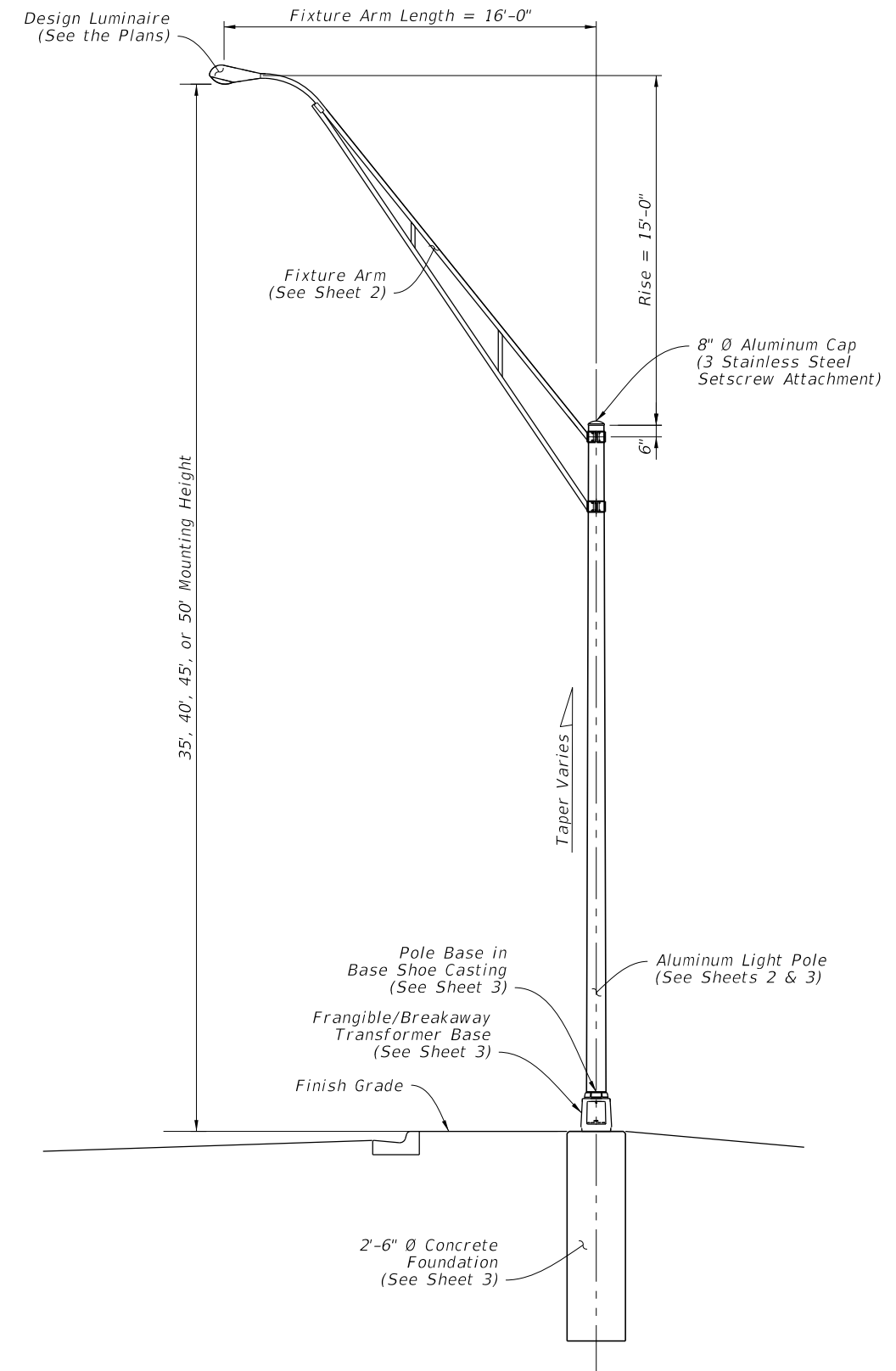

LIGHT POLE - ELEVATION

9/23/2021 7:54:47 AM

LAST REVISION 11/01/21	REVISION	DESCRIPTION:	 FY 2022-23 STANDARD PLANS	UTILITY CONFLICT POLE	INDEX 715-003	SHEET 1 of 3
---------------------------	----------	--------------	---	-----------------------	------------------	-----------------

9/23/2021 7:55:00 AM

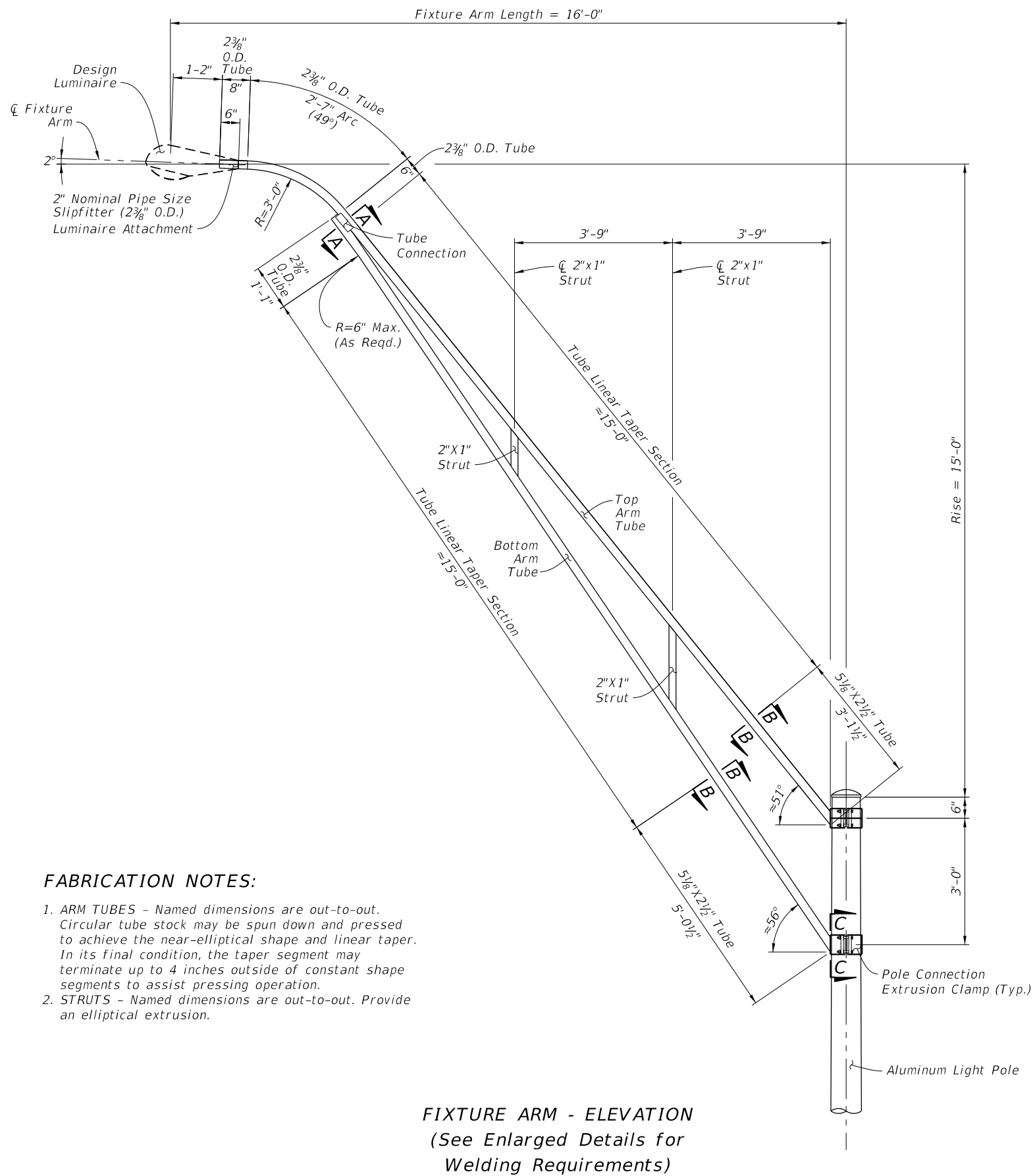

FIXTURE ARM - ELEVATION
(See Enlarged Details for Welding Requirements)

FABRICATION NOTES:

1. **ARM TUBES** - Named dimensions are out-to-out. Circular tube stock may be spun down and pressed to achieve the near-elliptical shape and linear taper. In its final condition, the taper segment may terminate up to 4 inches outside of constant shape segments to assist pressing operation.
2. **STRUTS** - Named dimensions are out-to-out. Provide an elliptical extrusion.

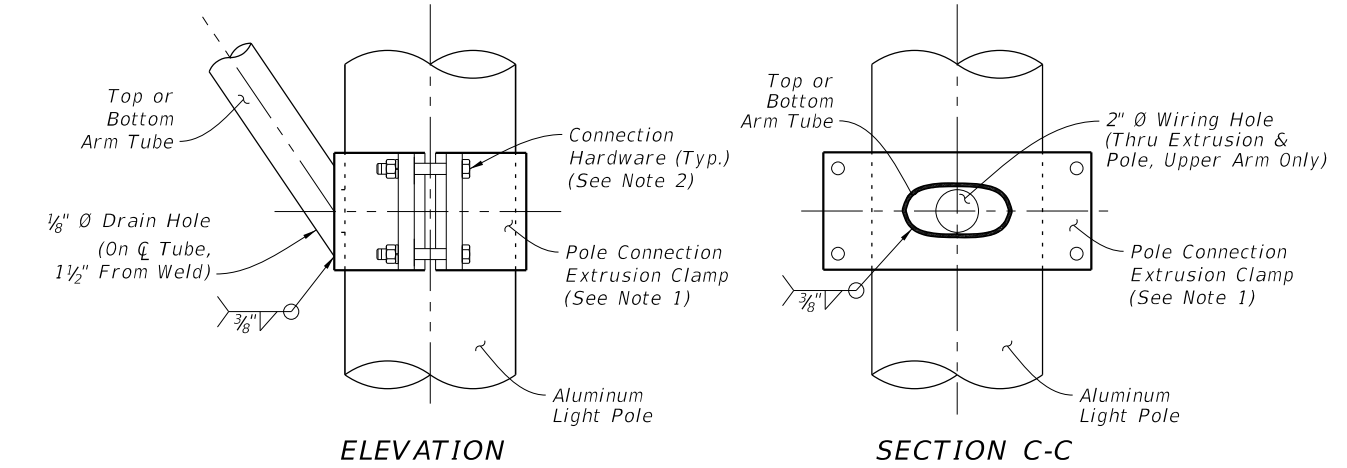

ELEVATION

SECTION C-C

POLE CONNECTION NOTES:

1. The Pole Connection Extrusion Clamp shown may vary by manufacturer. Provide a design that meets the requirements of General Note 6.B.a., including the connection hardware sizing.
2. Provide connection hardware with 13NC AISI Grade 316 stainless steel 1/2 inch min. bolts, nuts, and spring lock washers. Use flat washers per ASTM F593G & F594G, Alloy Group 2, Condition CW1.

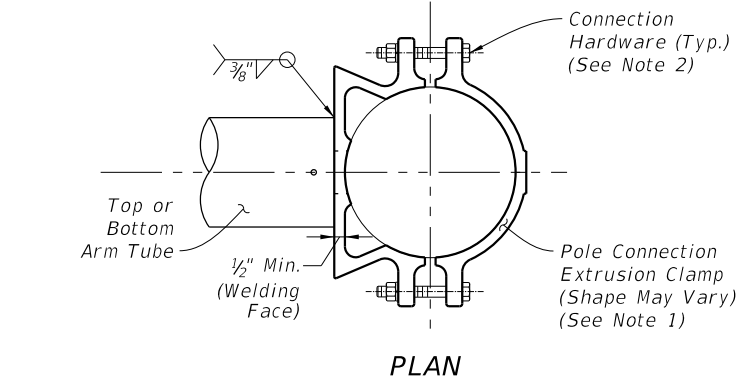

PLAN

POLE CONNECTION DETAILS

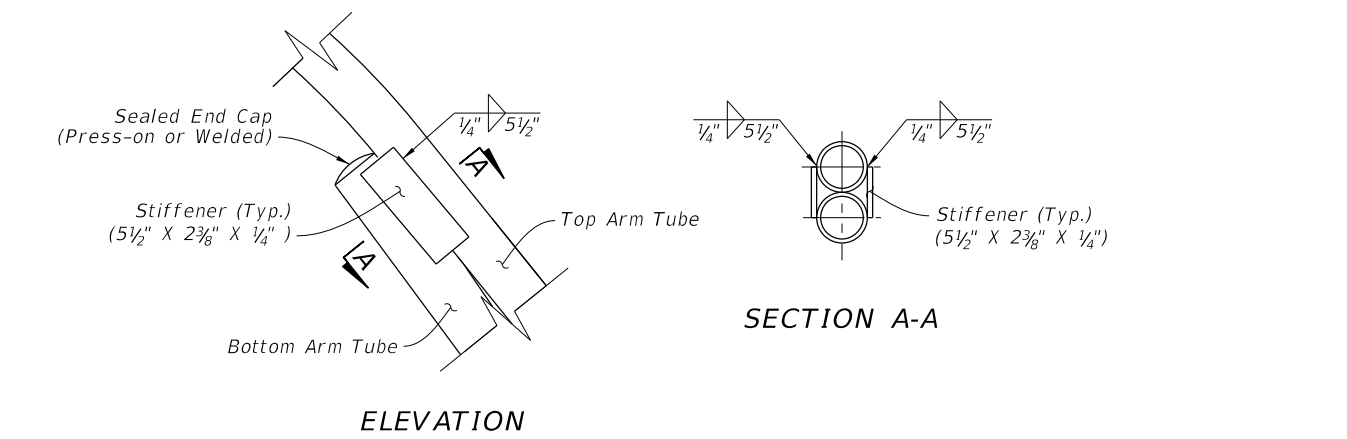

ELEVATION

SECTION A-A

TUBE CONNECTION DETAILS

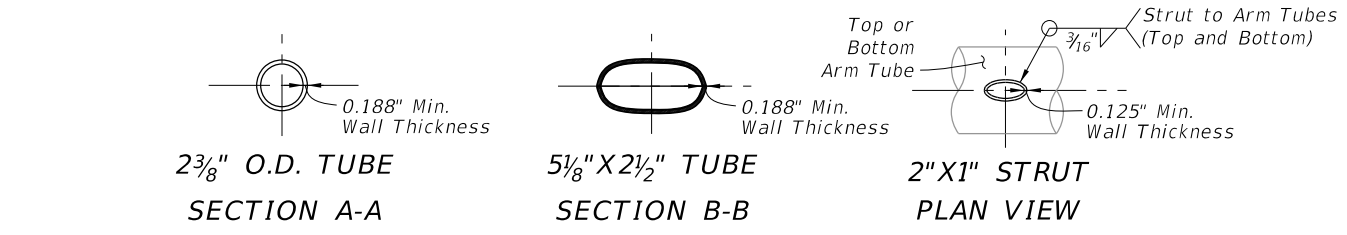

2 3/8" O.D. TUBE SECTION A-A

5 1/8" X 2 1/2" TUBE SECTION B-B

2" X 1" STRUT PLAN VIEW

TUBE SECTION DETAILS

FIXTURE ARM ASSEMBLY

LAST REVISION 11/01/21	DESCRIPTION:	 FY 2022-23 STANDARD PLANS	UTILITY CONFLICT POLE	INDEX 715-003	SHEET 2 of 3
---------------------------	--------------	----------------------------------	------------------------------	------------------	-----------------

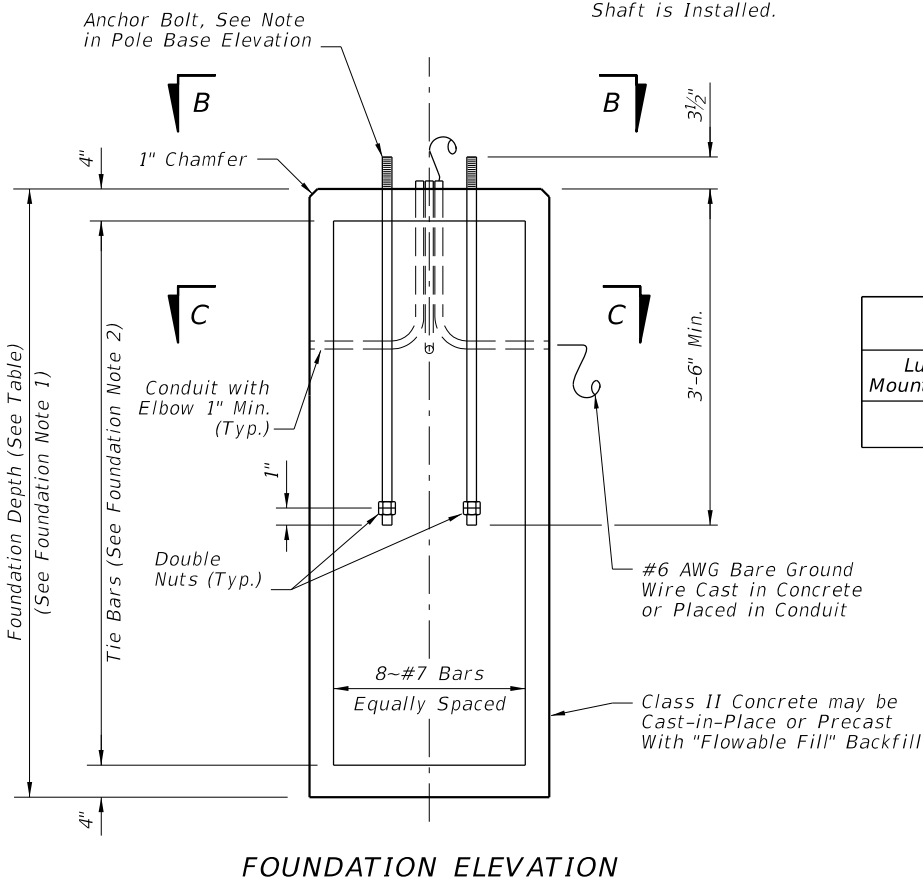
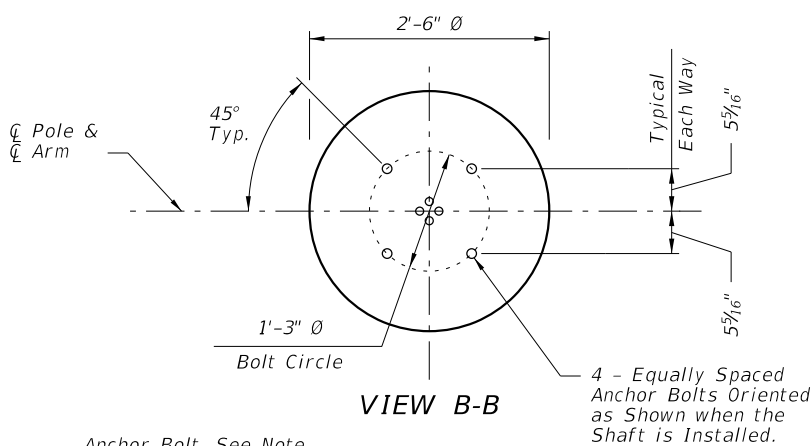
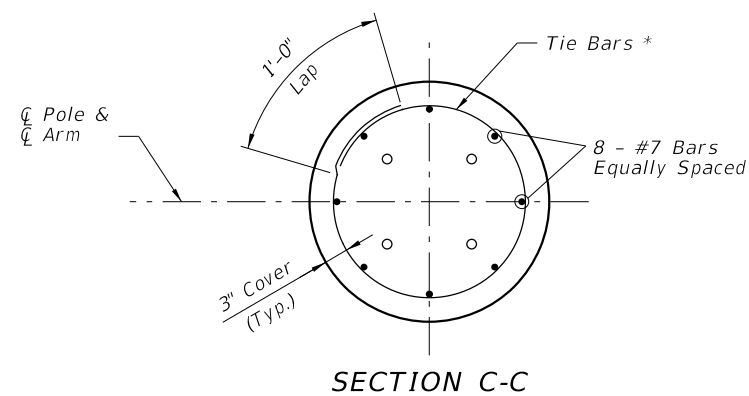

FOUNDATION DEPTHS		
Luminaire Mounting Height	≤ 40 Ft.	45-50 Ft.
Depth	8'-0"	9'-0"

FOUNDATION NOTES:

1. Depths shown are for slopes equal to or flatter than 1:4. For slopes steeper than 1:4 and equal to or flatter than 1:2 add 2'-6" to foundation depths shown.
2. Foundation Tie Bars: #4 Tie Bars @ 12" centers (max.) or D10 (or W10) spiral @ 6" pitch, 3 flat turns top and 1 flat turn bottom.

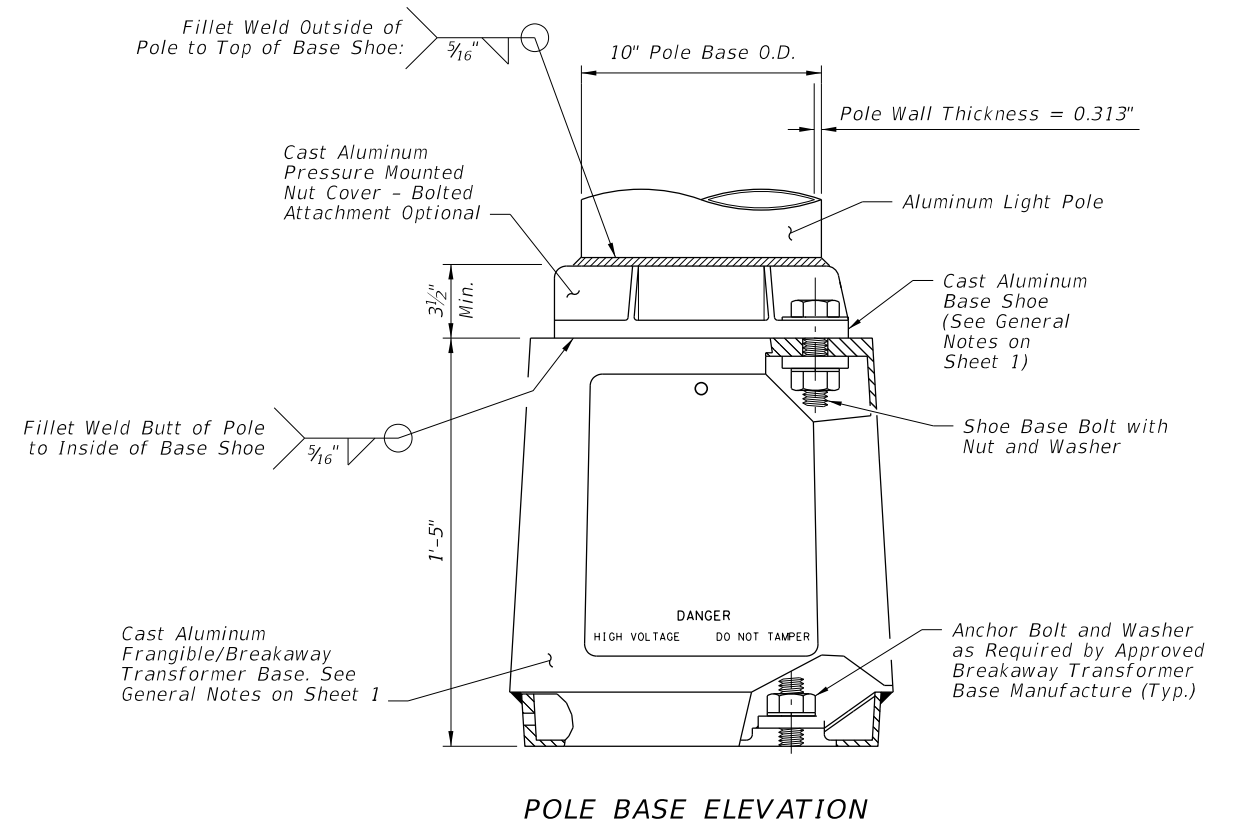
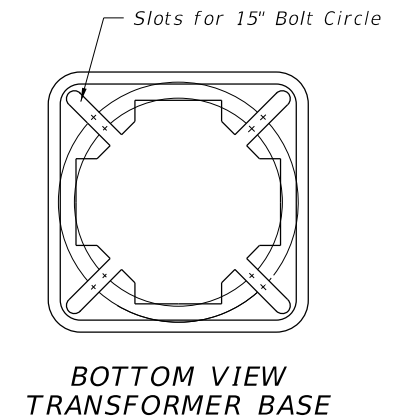
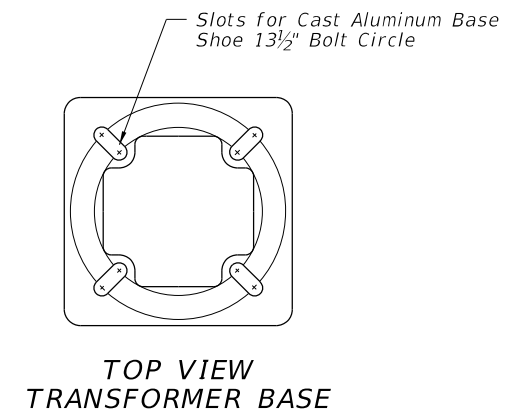

FOUNDATION AND BASE DETAILS

9/23/2021 7:55:01 AM

LAST REVISION 11/01/21	DESCRIPTION:
---------------------------	--------------

**FY 2022-23
STANDARD PLANS**

UTILITY CONFLICT POLE

INDEX 715-003	SHEET 3 of 3
------------------	-----------------