

GENERAL NOTES:

1. Refer to Index 700-010 for additional notes, assembly of base connection and material specifications not given in this Index.
2. Aluminum Columns: ASTM B429 Alloy 6061-T6.
3. Place galvanized steel shims between the Sleeve and Post to obtain a tight fit between the Post and Sleeve.
4. Wind Beam and Vertical Brace: Aluminum Z 3 x 2¹/₁₆ x 3.38. Install Vertical Brace on 7'-0" to 8'-0" signs only.
5. Provide 2 ~ 0.0149" Thick (28 gauge) and 2 ~ 0.0329" Thick (21 gauge) Brass Shims Per Post. Used brass shims to plumb the post.
6. Use nylon washers under the button bolt heads to protect sign sheeting. Use aluminum washers under nut.

COLUMN SELECTION AND FOOTING SIZE TABLE							
Sign Size Height x Length	Column Size Diameter x Thickness	Sleeve Size Diameter x Thickness	U-bolt Diameter	Base Bolt Diameter x Length	Torque lbs./in	Base Plate Thickness	Footing Depth
4'-0" x 5'-0"	4 NPS Schedule 80 (4.5" x 0.337")	5 NPS Schedule 120 (5.563" x 0.5")	1/2"	5/8" x 3 1/2"	270 ± 45	1"	6'-0"
4'-0" x 6'-0"							
4'-0" x 7'-0"	5 NPS Schedule 80 (5.563" x 0.375")	6 NPS Schedule 80 (6.625" x 0.432")	5/8"	3/4" x 4"	445 ± 75	1 1/8"	6'-6"
4'-0" x 8'-0"							7'-0"

TYPICAL SECTION

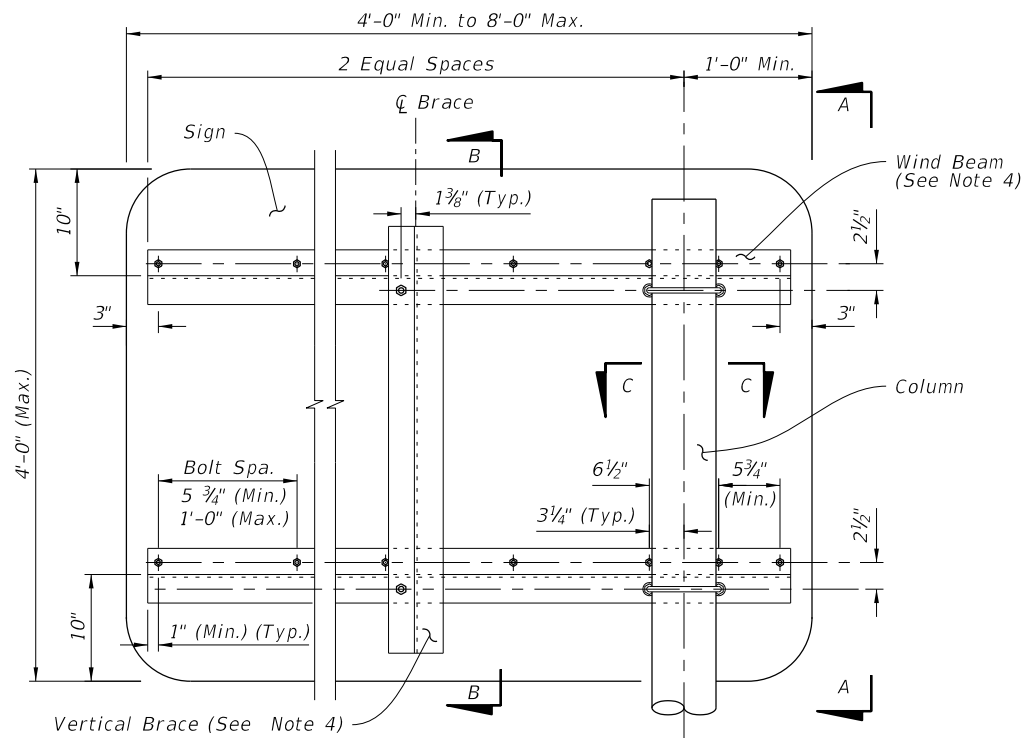

SIGN DETAIL

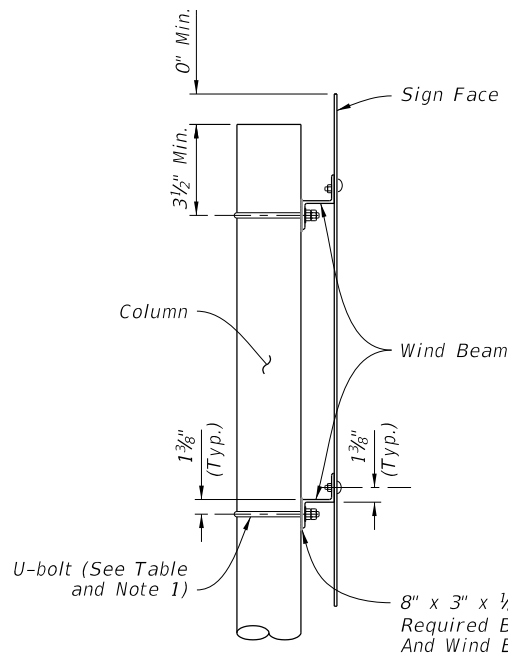

VIEW A-A

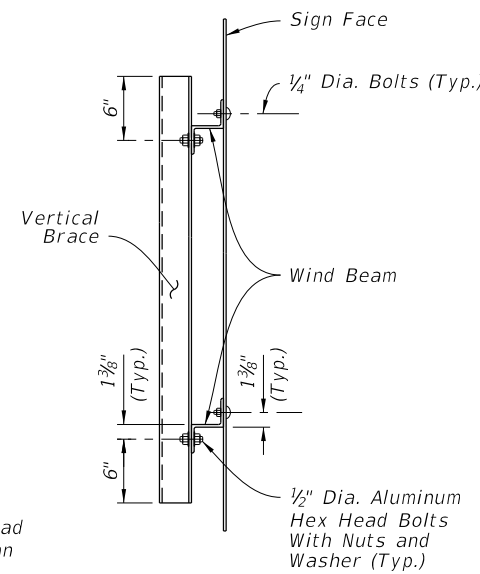

SECTION B-B

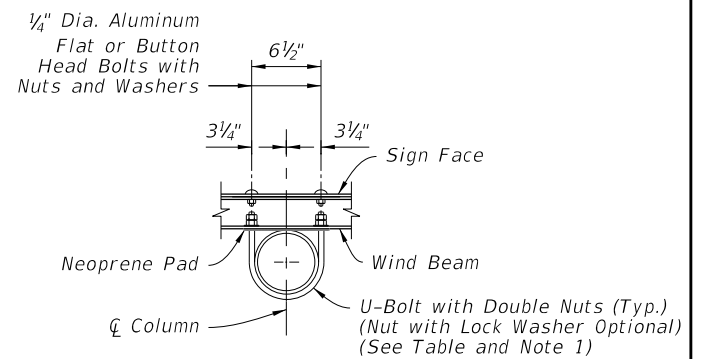

SECTION C-C

9/22/2021 1:43:37 PM

LAST REVISION	DESCRIPTION:
11/01/20	



**FY 2022-23
STANDARD PLANS**

**SINGLE COLUMN CANTILEVER
GROUND MOUNTED SIGN**

INDEX
700-011

SHEET
1 of 2

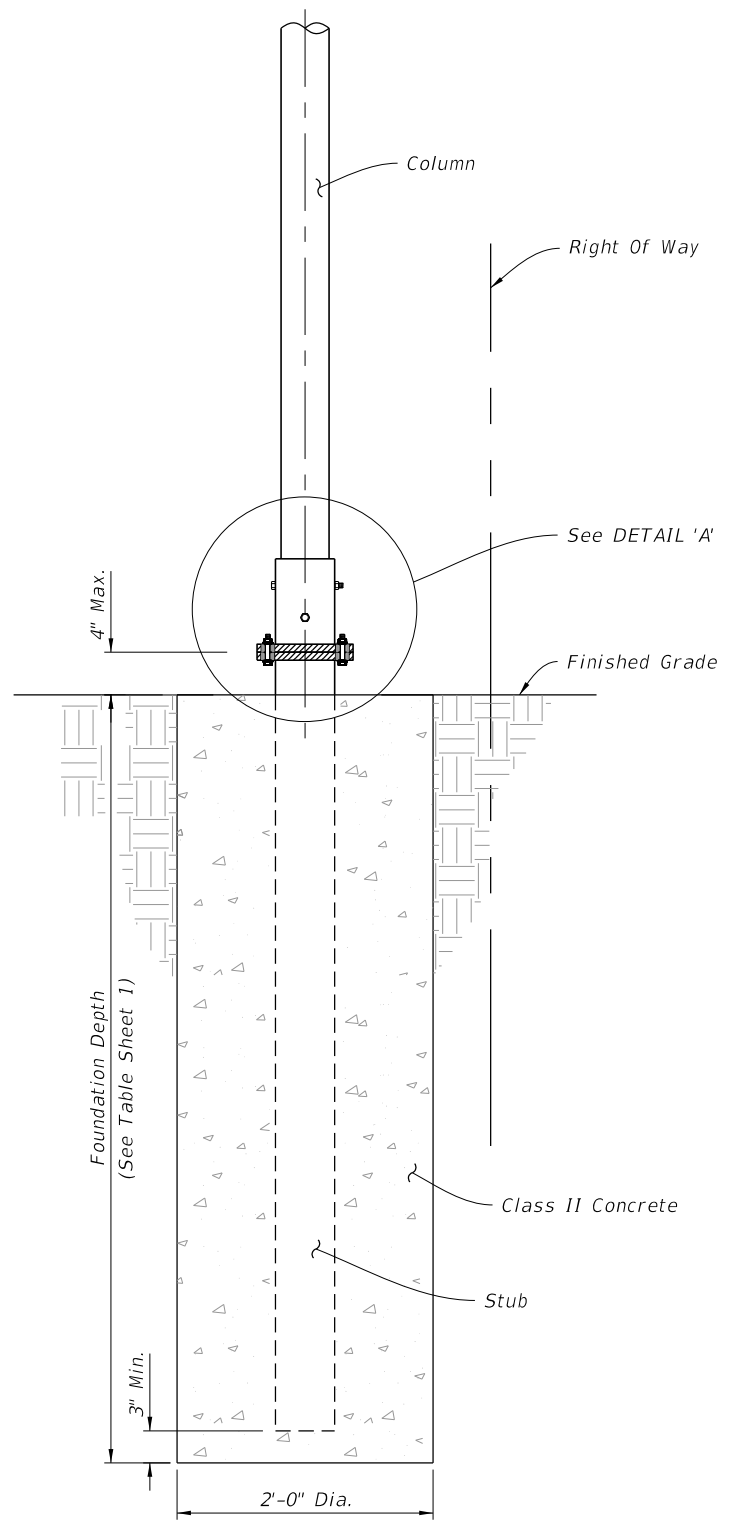

BASE AND FOUNDATION DETAIL

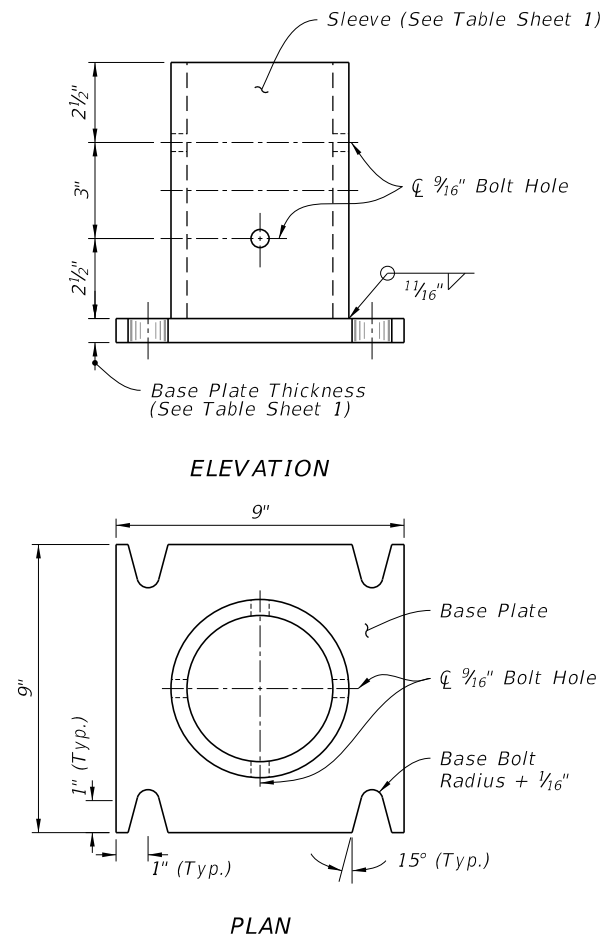

SLEEVE & BASE PLATE DETAILS

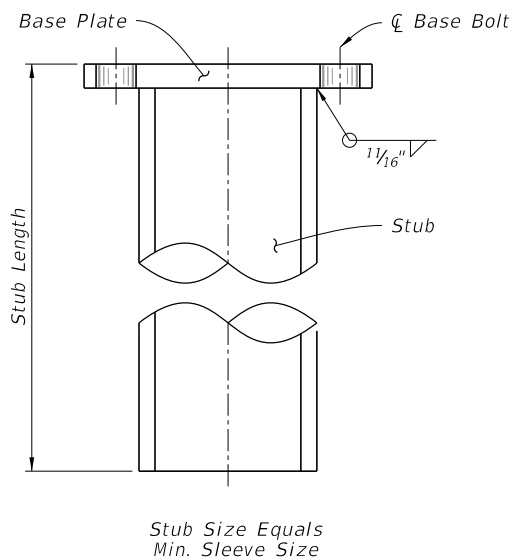

STUB DETAIL

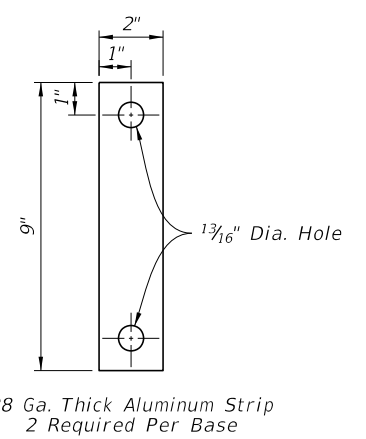

BOLT KEEPER PLATE DETAIL

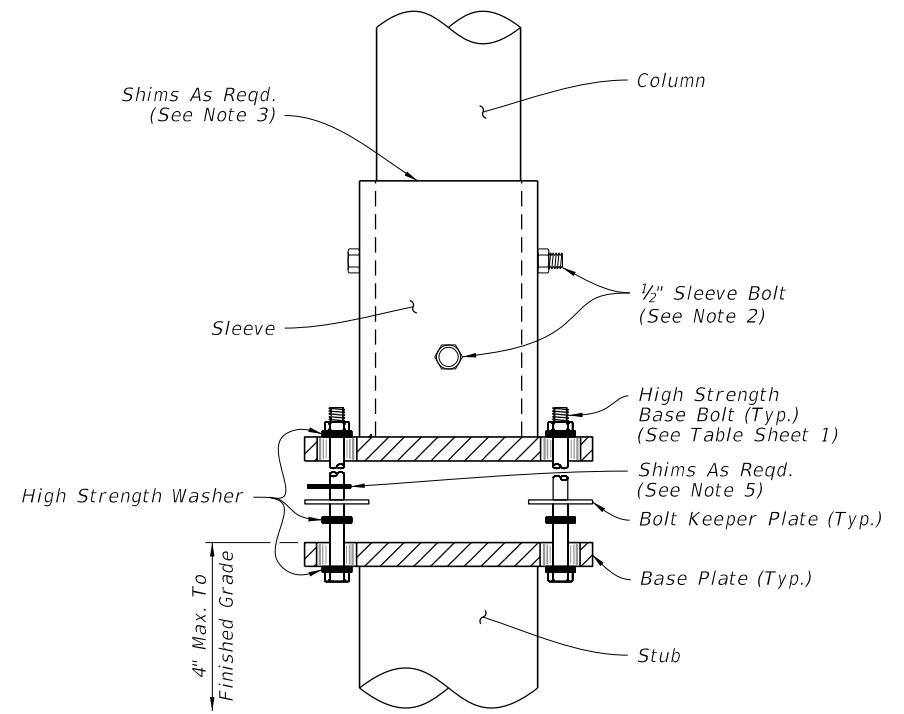

DETAIL 'A'

9/22/2021 1:43:40 PM

LAST REVISION 11/01/21	REVISION	DESCRIPTION:		FY 2022-23 STANDARD PLANS	SINGLE COLUMN CANTILEVER GROUND MOUNTED SIGN	INDEX 700-011	SHEET 2 of 2
---------------------------	----------	--------------	--	------------------------------	---	------------------	-----------------