

SECTION MATTING FOR DITCH

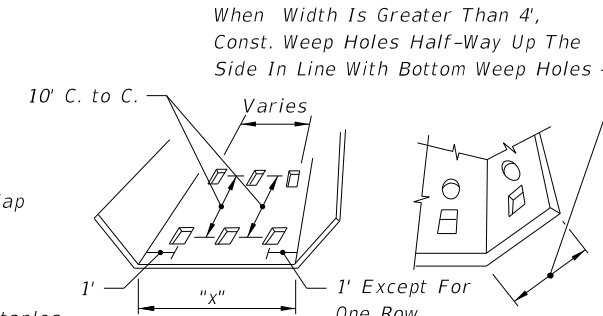

When "x" = 1' To 4' Const. 1 Row (Centered)
 "x" = 5' To 7' Const. 2 Rows
 "x" = 8' To 12' Const. 3 Rows
 "x" = 13' To 17' Const. 4 Rows
 "x" = 18' To 22' Const. 5 Rows

Note: All weep holes to be 3"x4" rectangle or 4" or 5" dia. circle hole. 1/2 cu. ft. (12" x 12" x 6") of No. 6 aggregate to be placed under each hole. 1 sq. ft. of galv. wire mesh (1/4" openings) shall be placed between the aggregate and the ditch pavement. Cost of holes, aggregate and wire mesh to be included in the cost of ditch pavement.

WEEP HOLE ARRANGEMENT

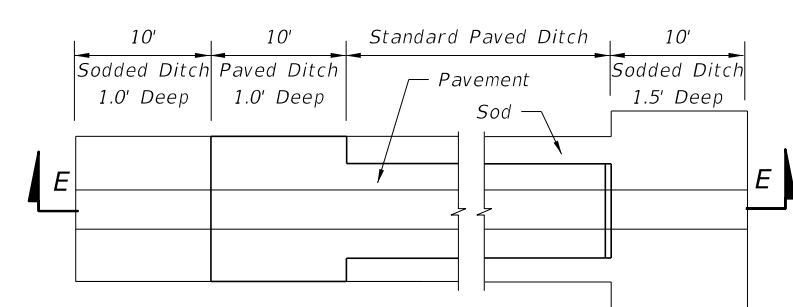
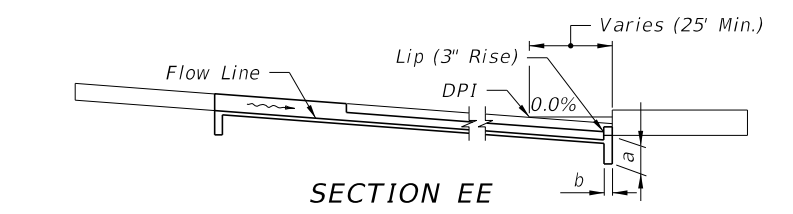

PAVED DITCH END TREATMENT

TO REPLACE:	W	d	R	Rows Of Weep Holes	Arc Length
6' Median Swale	6'	0.24'	19'	0	6.0'
1:6 Front Slopes; 1:4 Back Slope					
5' Ditch Bottom Width	10'	0.67'	19'	2	10.1'
4' Ditch Bottom Width	9'	0.54'	19'	2	9.1'
1:4 Front Slopes & Back Slope					
5' Ditch Bottom Width	9'	0.74'	14'	2	9.2'
4' Ditch Bottom Width	8'	0.58'	14'	1 (in center)	8.1'

For use only where side slopes are 1:4 or flatter. Point "A" and "B" are to be the same elevation and should be used to locate the paved section.

ALTERNATE DITCH PAVEMENT

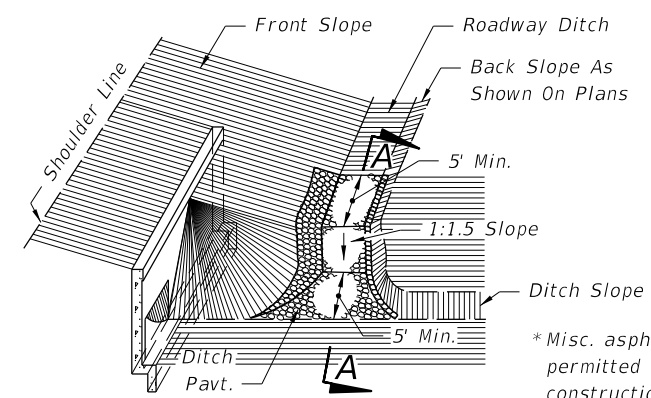

JUNCTION OF ROADWAY DITCH* AND LATERAL DITCH

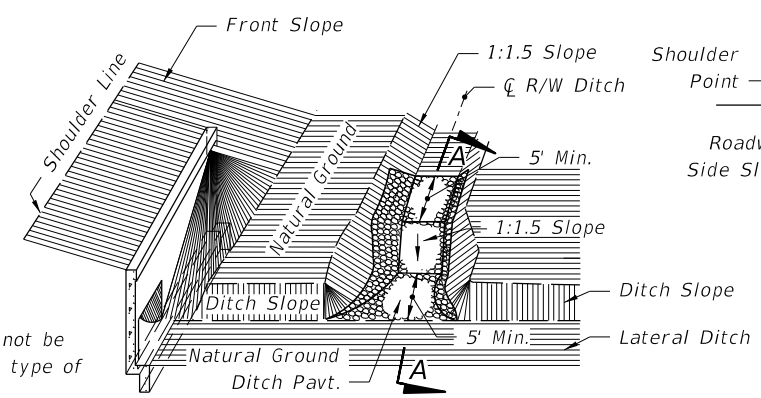

JUNCTION OF R/W DITCH* AND LATERAL DITCH

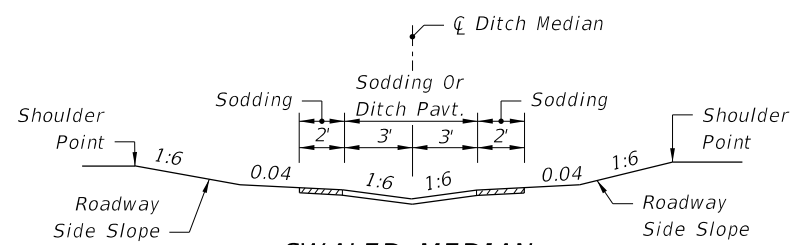

SWALED MEDIAN (No Weep Holes)

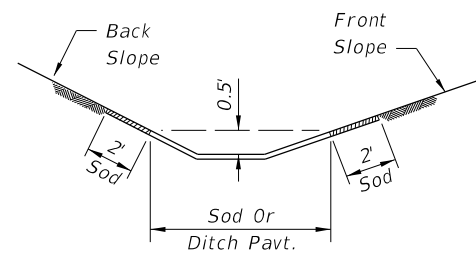

ROADWAY SIDE DITCH

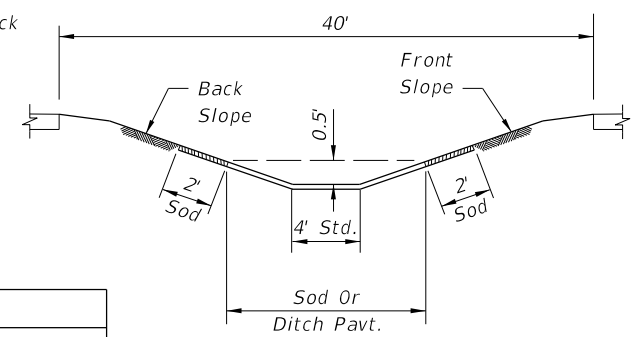

40' MEDIAN

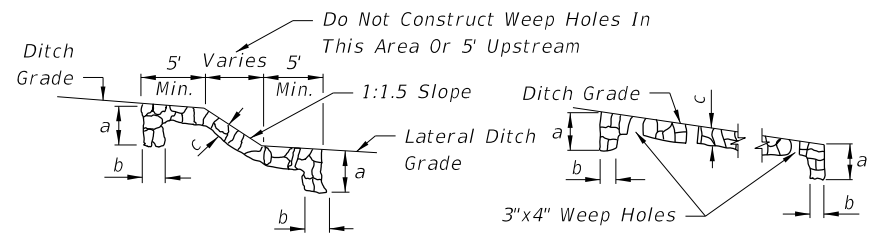

SECTION AA PROFILE OF DITCH PAVEMENT AT LOCATIONS OTHER THAN JUNCTION WITH LATERAL DITCH

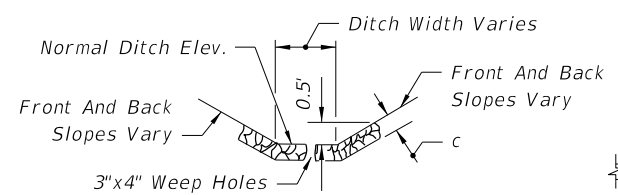

TYPICAL SECTION

TABLE 1: DITCH PAVEMENT

Pavement Type	Dimensions			Payment Unit	Basis Of Estimate	Filter Fabric Type	Velocity Range	References & Remarks
	a	b	c					
Concrete	24"	6"	Varies	SY	SY	D-4	Low-High	Specification 524
Miscellaneous Asphalt	24"	12"	4"	TN	0.2 TN/SY	None	Low-Moderate	Specification 339
Riprap (Sand-Cement)	24"	12"	4"	CY	0.11 CY/SY	D-4	Low-Moderate	Specification 530, Grouting of joints required
Riprap (Ditch Lining)				TN	TN	D-2	Moderate-High	Specification 530

- GENERAL NOTES**
- Type of ditch pavement shall be as shown on plans.
 - In concrete ditch pavement, contraction joints are to be spaced at 25' maximum intervals, or as directed by the Engineer. Contraction joints may be either formed (construction joint) or tooled. No open joints will be permitted in concrete ditch pavement.

Expansion joints with 1/2" preformed joint filler shall be constructed at all inlets, endwalls, and at intervals of not more than 200'.
 - Lip at end of ditch pavement shall normally be located downstream of DPI or on flatter grades where there is a decrease in ditch velocity.
 - Toewalls are to be used with all ditch paving. A toewall is not required adjacent to drainage structures.
 - When directed by the Engineer, weep hole spacing may be reduced to 5' minimum.
 - For junction of R/W ditch spillway and lateral ditch, sides of paving to be 1' high minimum.
 - Filter fabric is required under all ditch pavement, except for miscellaneous asphalt, regardless of the pavement thickness. Place the filter fabric directly beneath the pavement for the entire length and width of the pavement. See Specification 985 for fabric requirements and application.
 - When weep holes with aggregate are used, place filter fabric below the aggregate to form a mat continuous with the pavement filter fabric or underlapping the pavement filter fabric, if present.
 - Ditch pavement requiring reinforcement shall be detailed in the plans.
 - Cost of plastic filter fabric to be included in the contract unit price for ditch pavement.
 - Sodding to be paid for under contract unit price for Performance Turf, SY

9/22/2021 8:52:25 AM

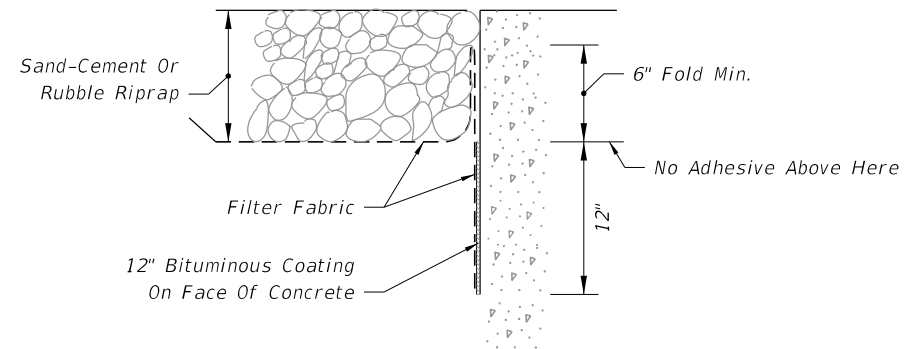

BONDED OPTION

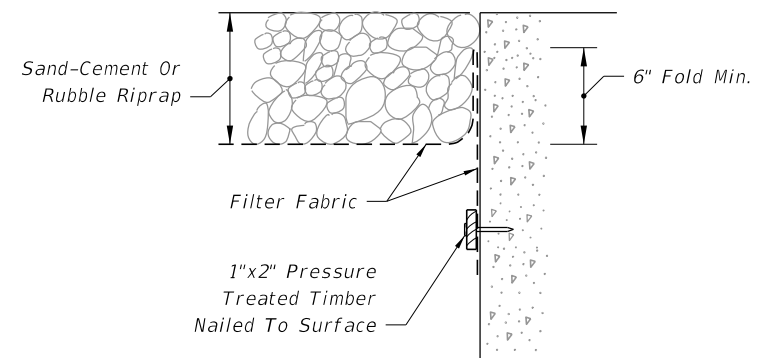

NAILED OPTION

Note: Either option may be used unless otherwise called for in the plans.

FILTER FABRIC PLACEMENT AT CONCRETE STRUCTURE

9/22/2021 8:52:28 AM

LAST REVISION 11/01/19	REVISION	DESCRIPTION:	 FY 2022-23 STANDARD PLANS	DITCH PAVEMENT AND SODDING	INDEX 524-001	SHEET 2 of 2
------------------------------	----------	--------------	---	-----------------------------------	-------------------------	------------------------