

GENERAL NOTES:

1. Cross Slopes and Grades:

- A. Sidewalk, ramp, and landing slopes (i.e. 0.02, 0.05, and 1:12) shown in this Index are maximums. With approval of the Engineer, provide the minimum feasible slope where the requirements cannot be met.
- B. Landings must have cross-slopes less than or equal to 0.02 in any direction.
- C. Maintain a single longitudinal slope along each side of the curb ramp. Ramp slopes are not required to exceed 15 feet in length.
- D. Joints permitted at the location of Slope Breaks. Otherwise locate joints in accordance with Index 522-001. No joints are permitted within the ramp portion of the Curb Ramp.

2. Curb, Curb and Gutter and/or Sidewalk:

- A. Refer to Index 522-001 for concrete thickness and sidewalk details.
- B. Remove any existing curb, curb and gutter, or sidewalk to the nearest joint beyond the curb transition or to the extent that no remaining section is less than 5 feet long.
- C. Width of Curb Ramp is 4'-0" minimum. Match sidewalk or Shared Use Path width as shown in the Plans.

3. Curb Ramp Alpha-Identification:

- A. Sidewalk curb ramp alpha-identifications (e.g. CR-A) are provided for reference purposes in the Plans.
- B. Alpha-identifications CR-I and CR-J are intentionally omitted.

4. Detectable Warnings:

- A. Install detectable warnings in accordance with Specification 527.
- B. Place detectable warnings across the full width of the ramp or landing, to a minimum depth of 2 feet measured perpendicular to the curb line and no greater than 5 feet from the back of the curb or edge of pavement.
- C. If detectable warnings are shown in the Plans on slopes greater than 5%, align the truncated domes with the centerline of the ramp; otherwise, the truncated domes are not required to be aligned.

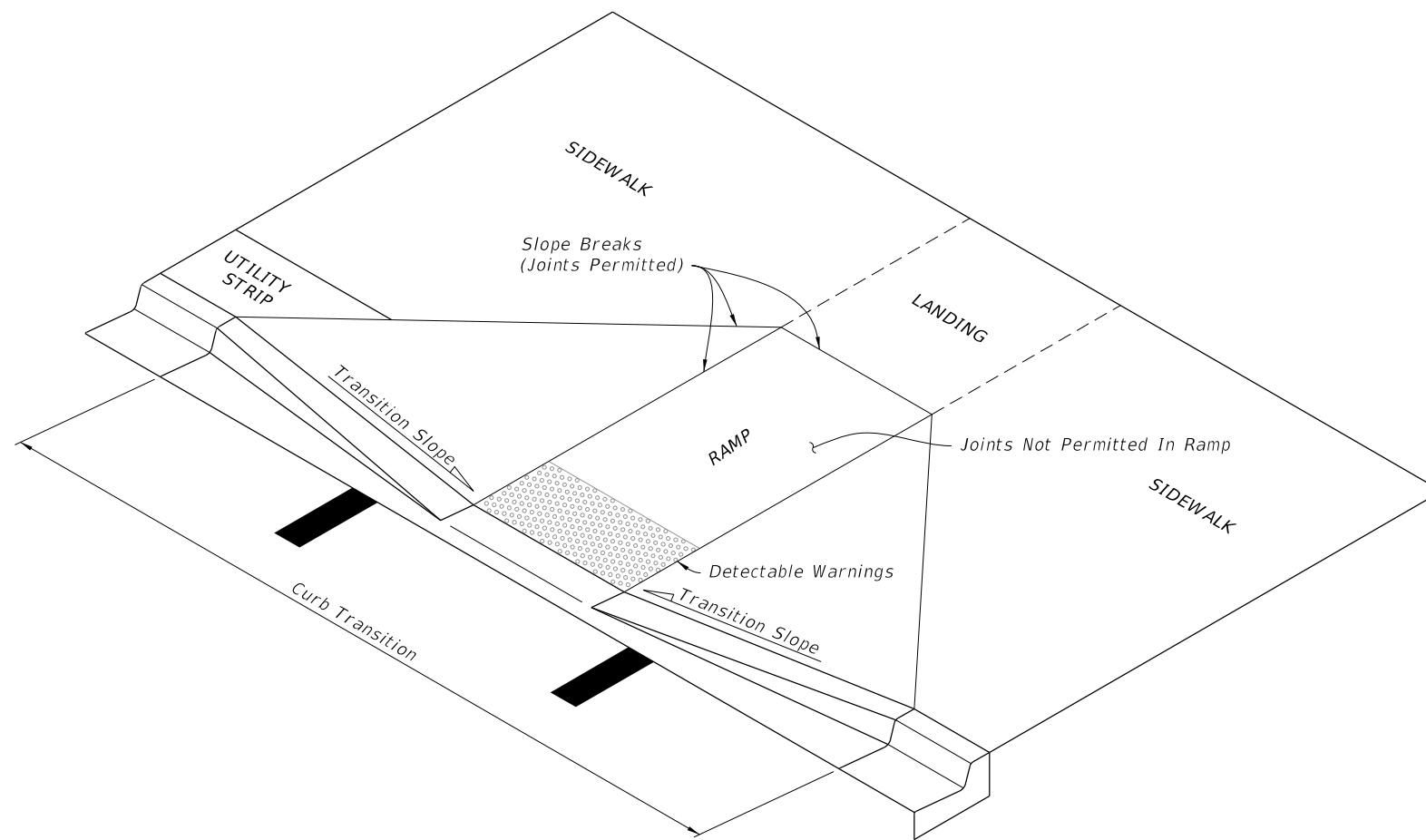

==== CURB RAMP NOMENCLATURE ====

9/22/2021 8:50:28 AM

LAST REVISION 11/01/21	REVISION	DESCRIPTION:	 FY 2022-23 STANDARD PLANS	DETECTABLE WARNINGS AND SIDEWALK CURB RAMPS	INDEX 522-002	SHEET 1 of 7
------------------------------	----------	--------------	---	---	------------------	-----------------

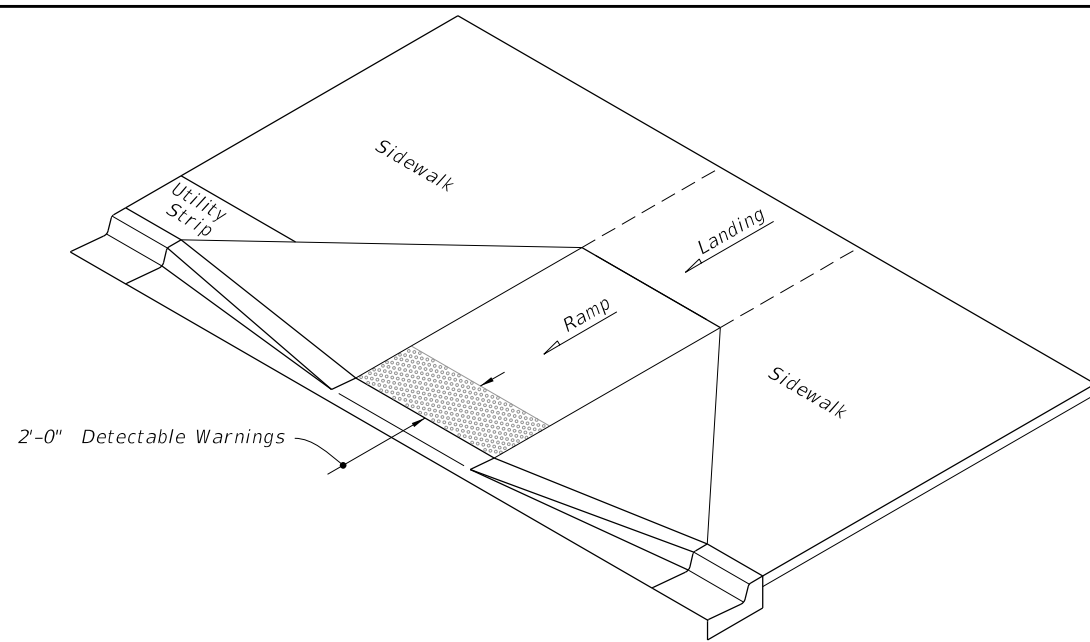

ISOMETRIC VIEW

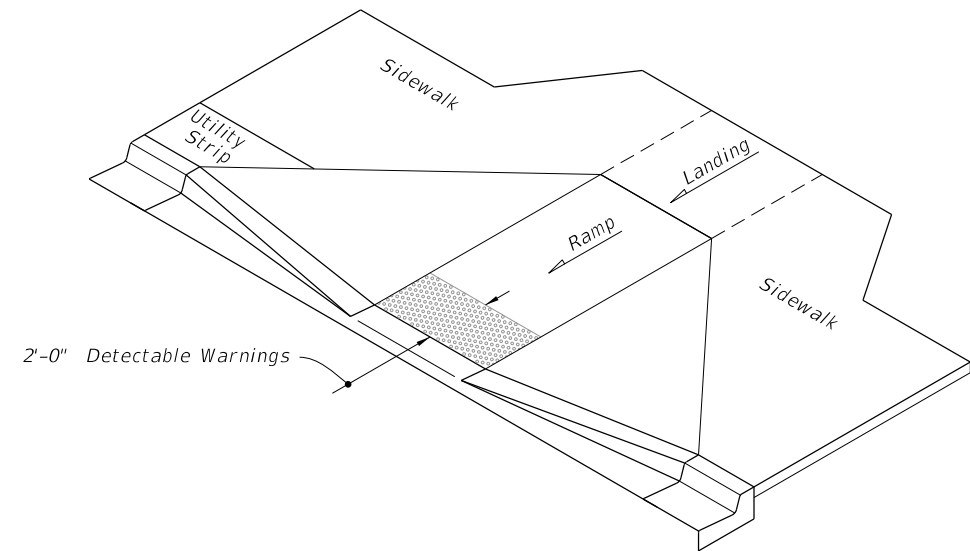

ISOMETRIC VIEW

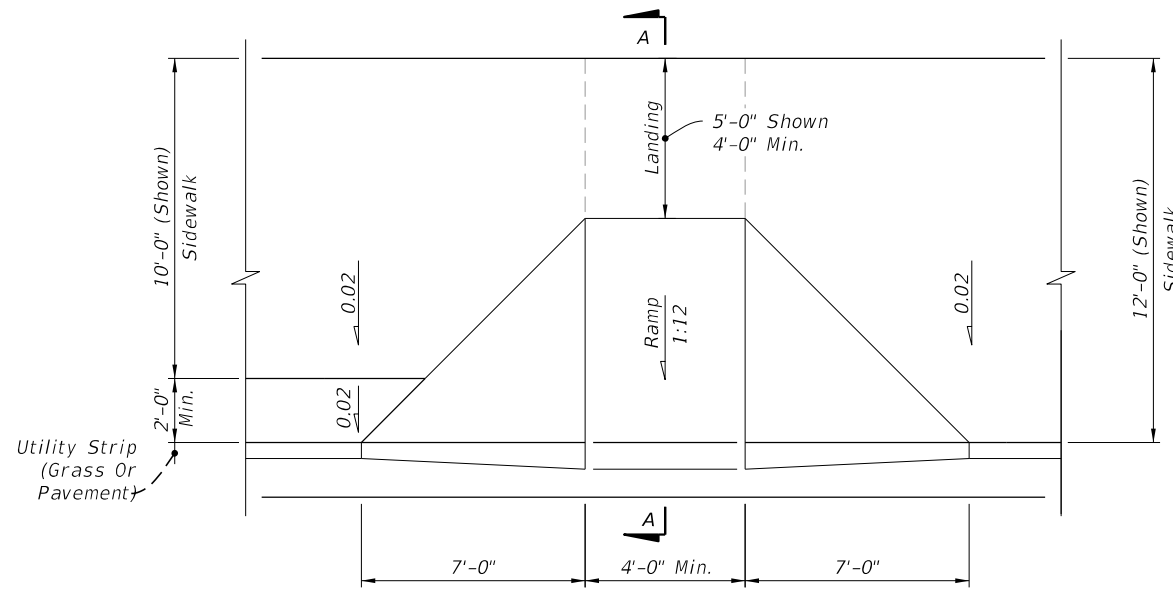

PLAN VIEW

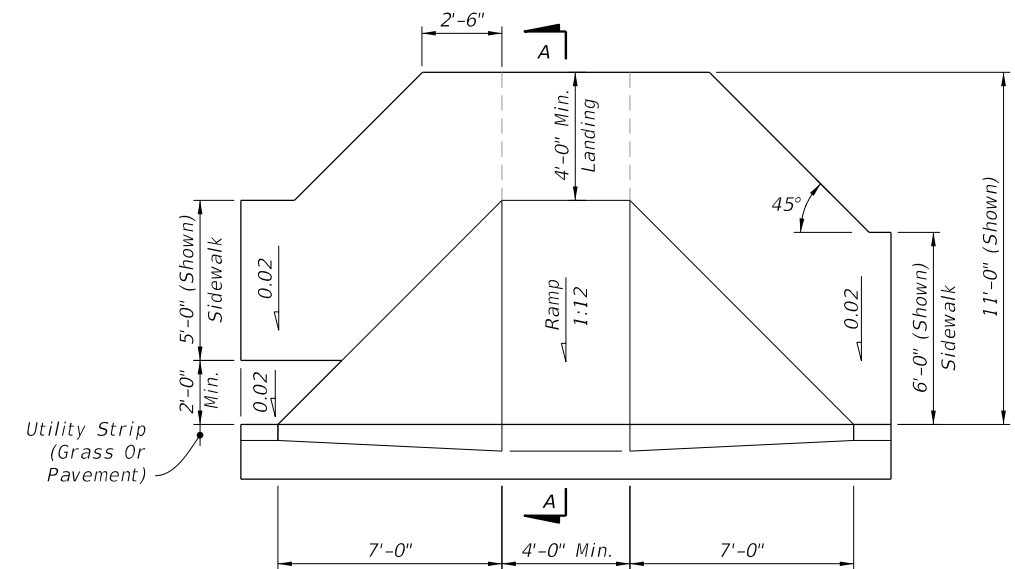

PLAN VIEW

NOTE: For Example of CR-A used in Radial Curb Returns, See Sheet 8.

CR-A

CR-B

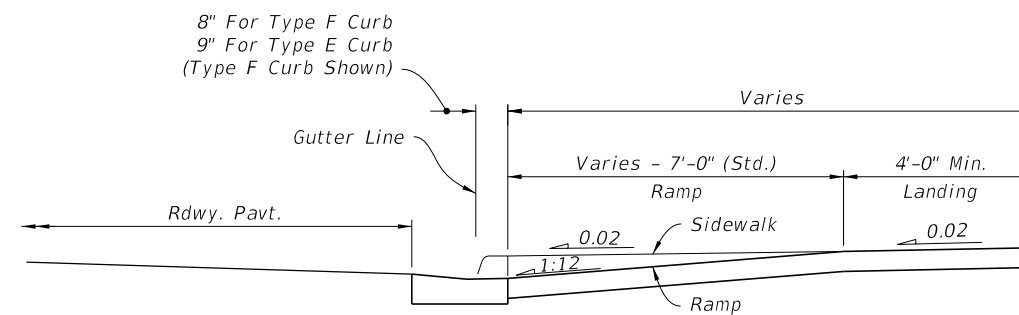

SECTION A-A

SIDEWALK CURB RAMPS CR-A AND CR-B

9/22/2021 8:50:30 AM

LAST REVISION 11/01/20	DESCRIPTION:
---------------------------	--------------

FY 2022-23
 STANDARD PLANS

DETECTABLE WARNINGS AND SIDEWALK CURB RAMPS

INDEX
522-002

SHEET
2 of 7

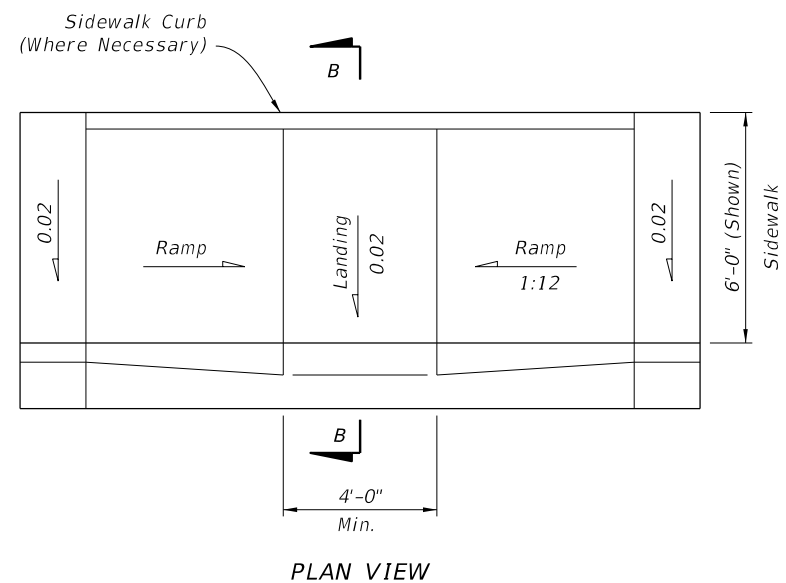

PLAN VIEW

CR-C

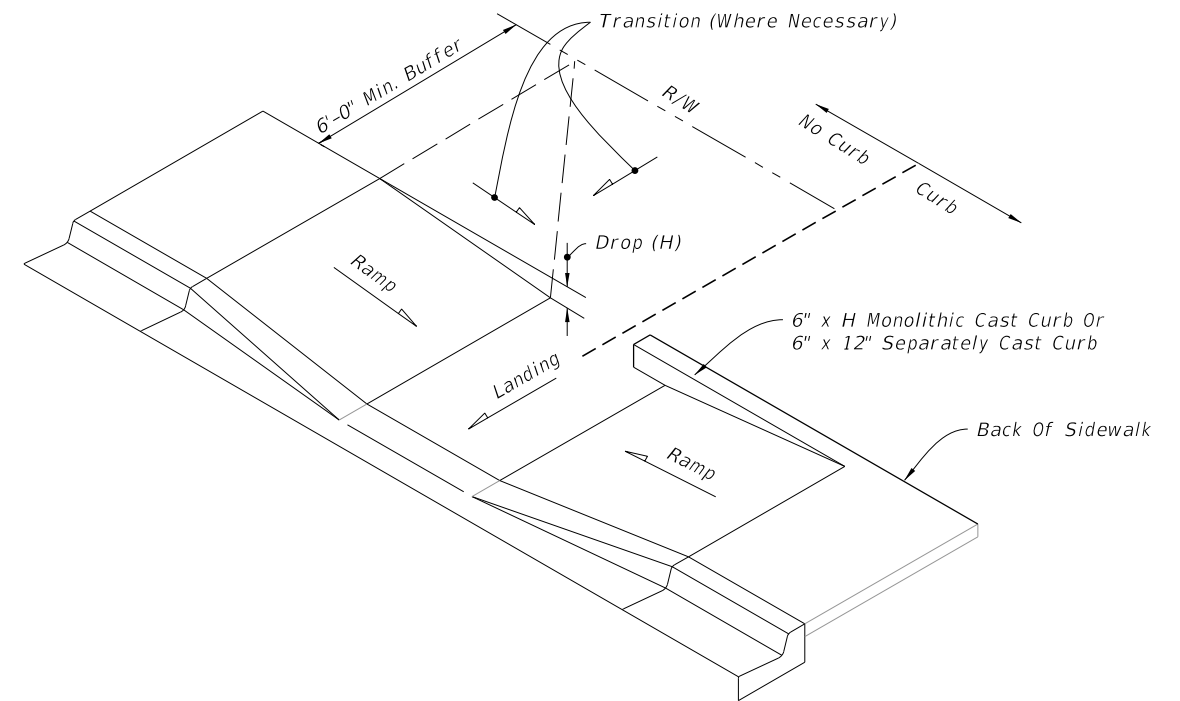

CONSTRUCTION OF SIDEWALK CURB IN CUT SECTIONS

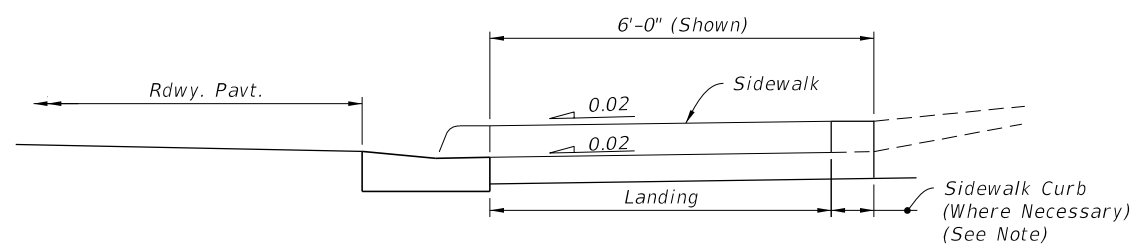

SECTION B-B

NOTE: For additional information on sidewalk curb construction, see SIDEWALK CURB OPTIONS details.

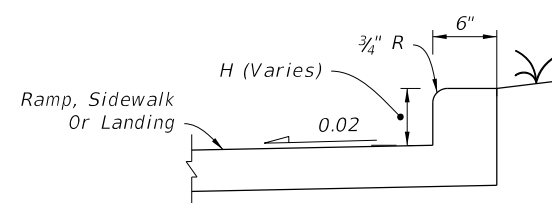

MONOLITHIC CAST CURB

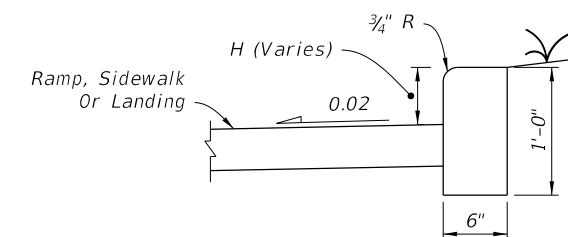

SEPARATELY CAST CURB

SIDEWALK CURB OPTIONS

SIDEWALK CURB RAMPS CR-C AND SIDEWALK CURB

9/22/2021 8:50:34 AM

LAST REVISION 11/01/20	REVISION	DESCRIPTION:	 FY 2022-23 STANDARD PLANS	DETECTABLE WARNINGS AND SIDEWALK CURB RAMPS	INDEX 522-002	SHEET 3 of 7
---------------------------	----------	--------------	--	---	------------------	-----------------

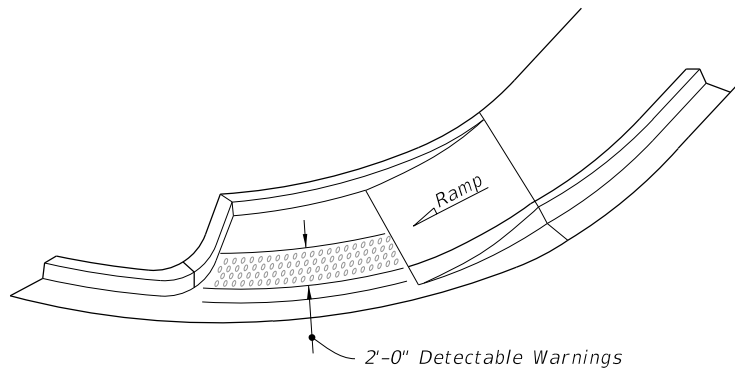

ISOMETRIC VIEW

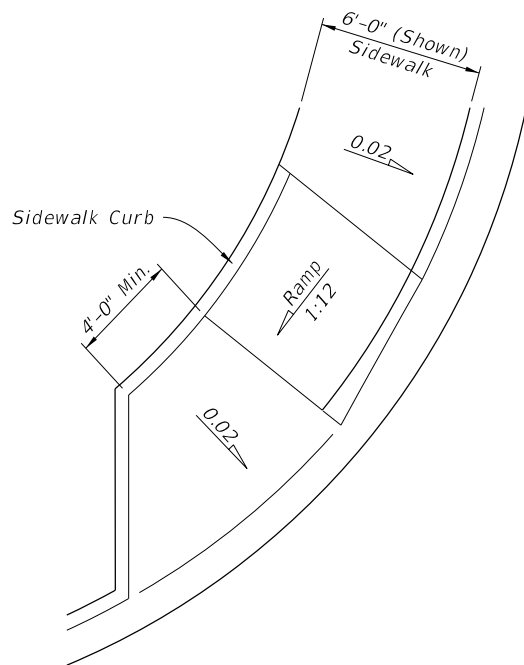

PLAN VIEW

CR-D

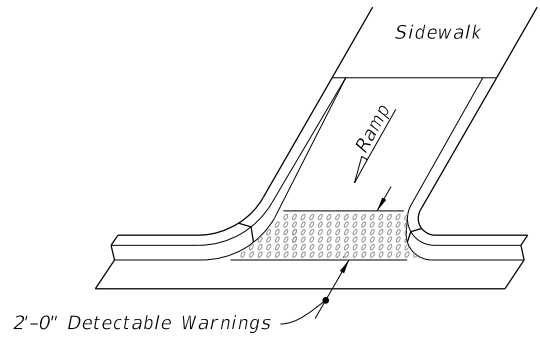

OPTION A

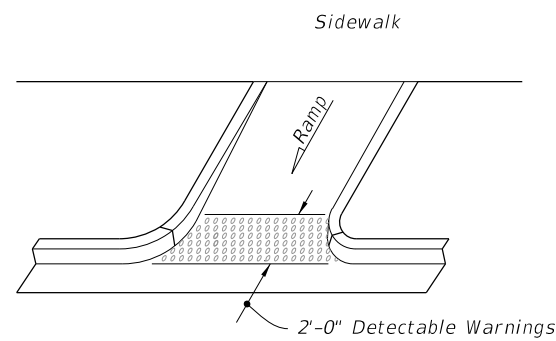

OPTION B
ISOMETRIC VIEW

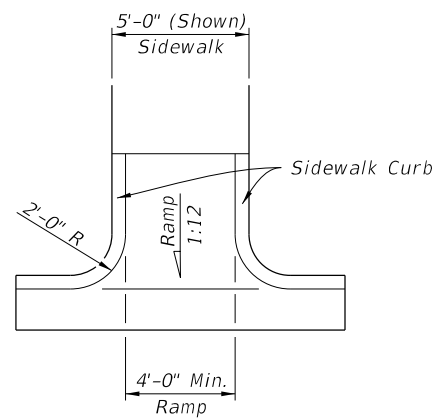

PLAN VIEW

CR-E

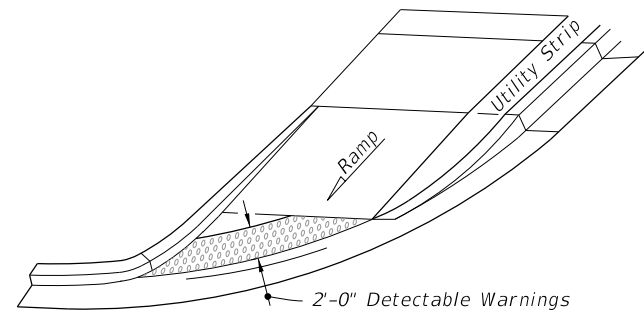

OPTION A

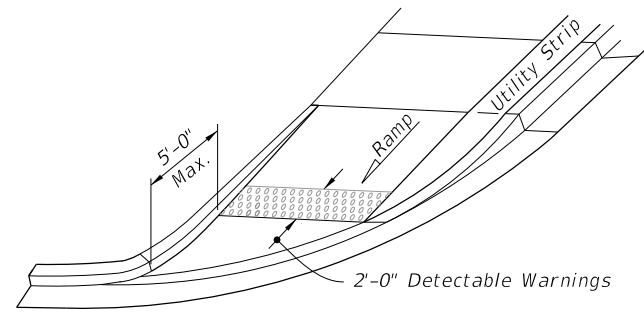

OPTION B
ISOMETRIC VIEW

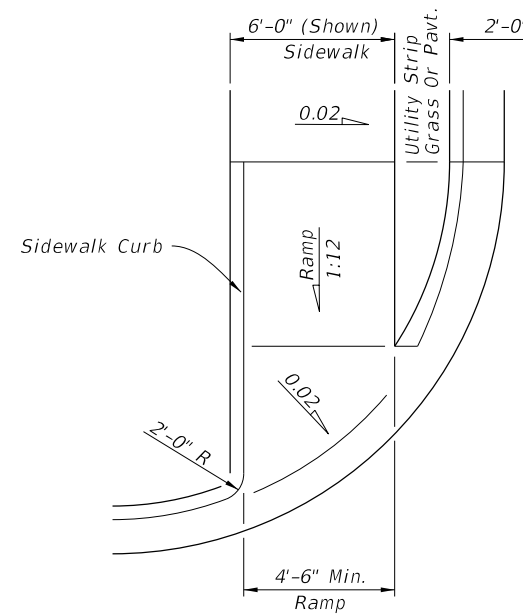

PLAN VIEW

CR-F

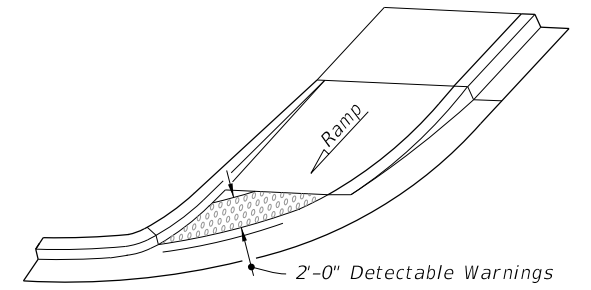

OPTION A

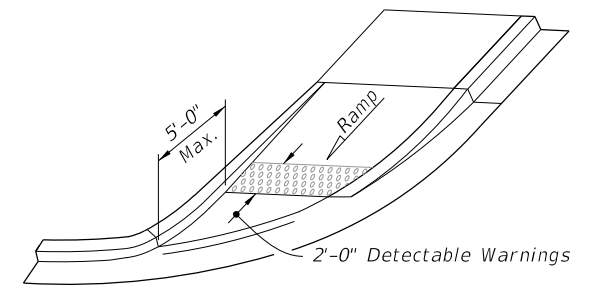

OPTION B
ISOMETRIC VIEW

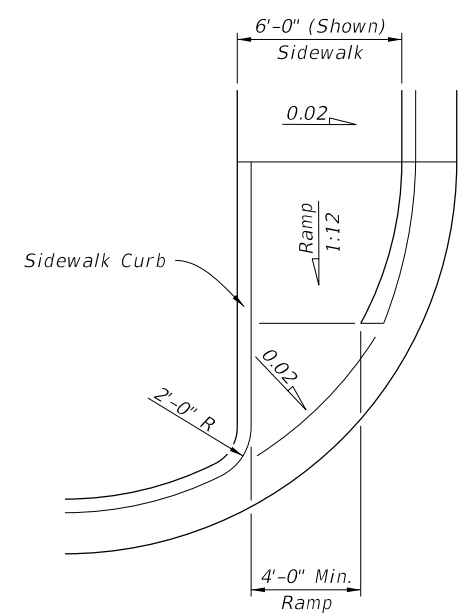

PLAN VIEW

CR-G

SIDEWALK CURB RAMPS CR-D, CR-E, CR-F & CR-G

9/22/2021 8:50:35 AM

LAST REVISION 11/01/21	DESCRIPTION:
---------------------------	--------------



FY 2022-23
STANDARD PLANS

DETECTABLE WARNINGS AND SIDEWALK CURB RAMPS

INDEX
522-002

SHEET
4 of 7

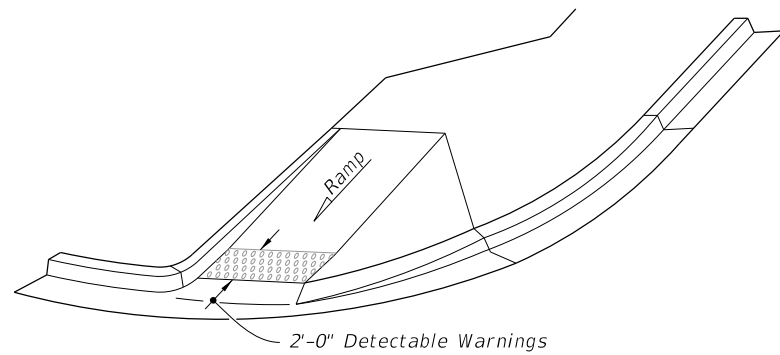

ISOMETRIC VIEW

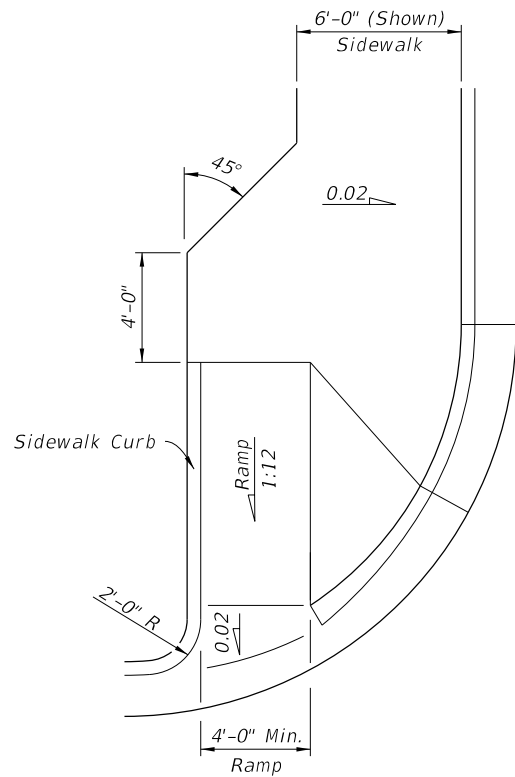

PLAN VIEW

CR-H

8" For Type F Curb
9" For Type E Curb
(Type F Curb Shown)

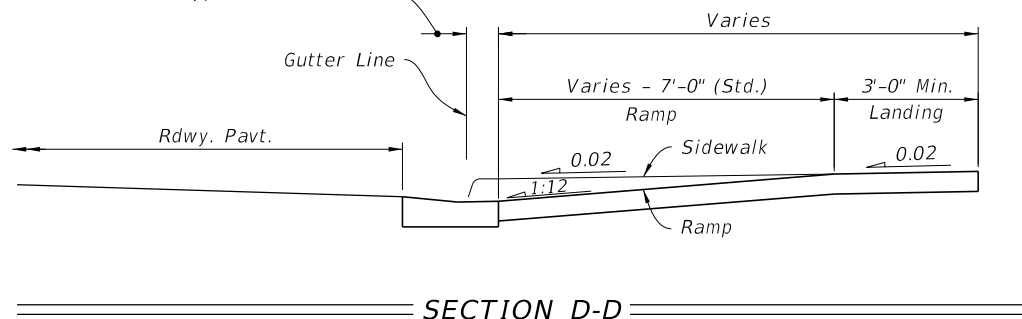

SECTION D-D

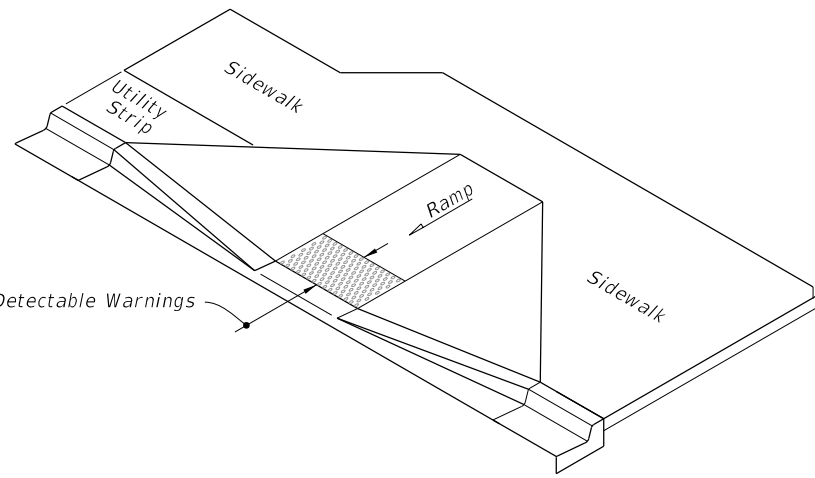

ISOMETRIC VIEW

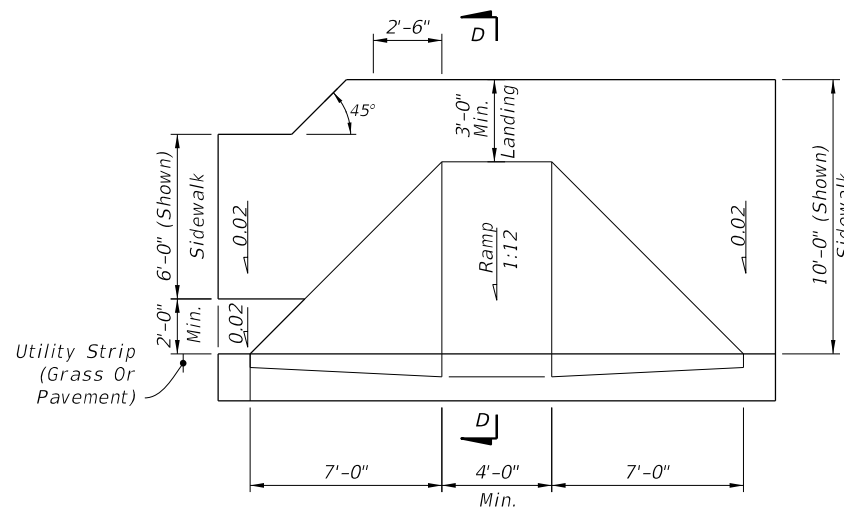

PLAN VIEW

CR-K

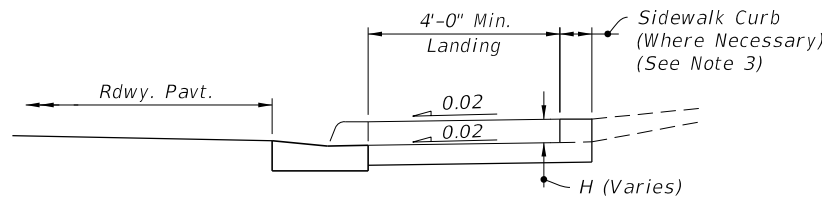

SECTION E-E

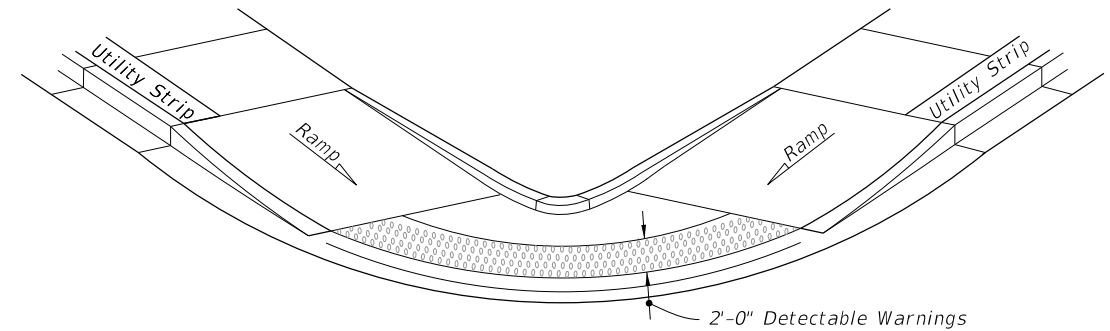

OPTION A

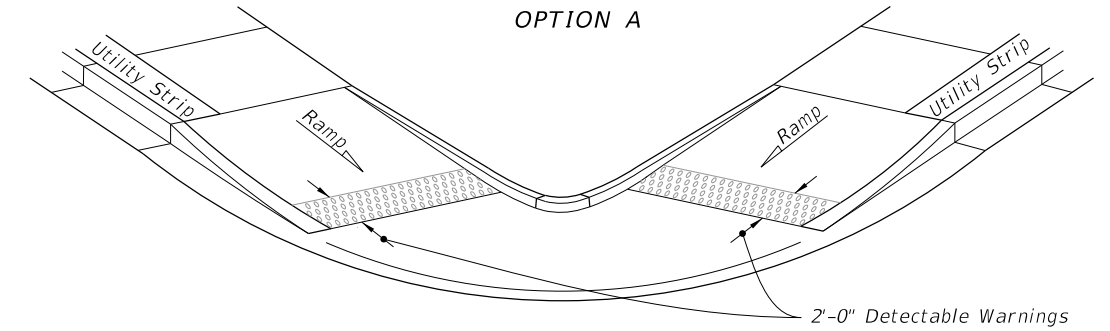

OPTION B

ISOMETRIC VIEW

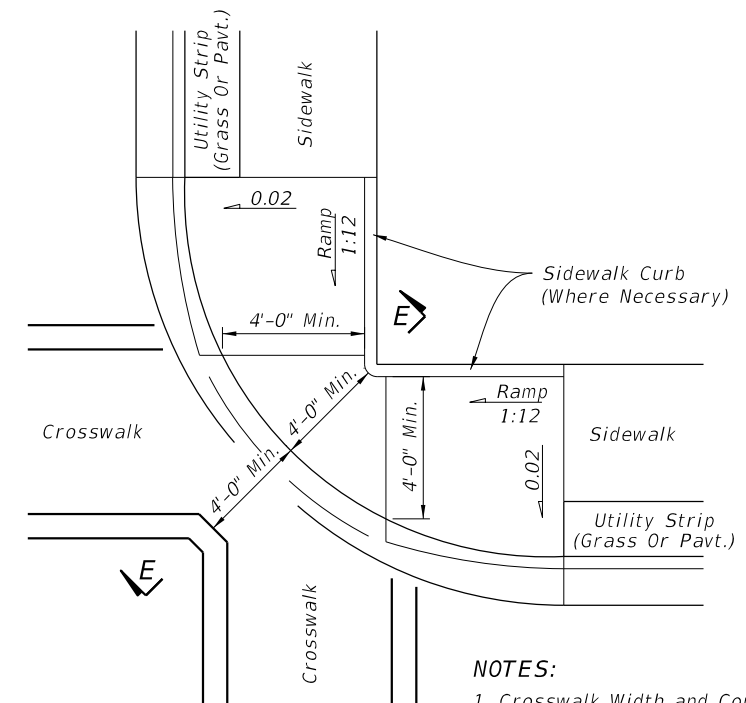

PLAN VIEW

CR-L

NOTES:

1. Crosswalk Width and Configuration Vary; Must Conform to Index 711-001.
2. 15' Radius Curve Shown for CR-L.
3. For additional information on sidewalk curb construction, see SIDEWALK CURB OPTIONS details, on Sheet 3.

SIDEWALK CURB RAMPS CR-H, CR-K & CR-L

9/22/2021 8:50:38 AM

LAST REVISION 11/01/20	DESCRIPTION:	 FY 2022-23 STANDARD PLANS	DETECTABLE WARNINGS AND SIDEWALK CURB RAMPS	INDEX 522-002	SHEET 5 of 7
---------------------------	--------------	--	---	------------------	-----------------

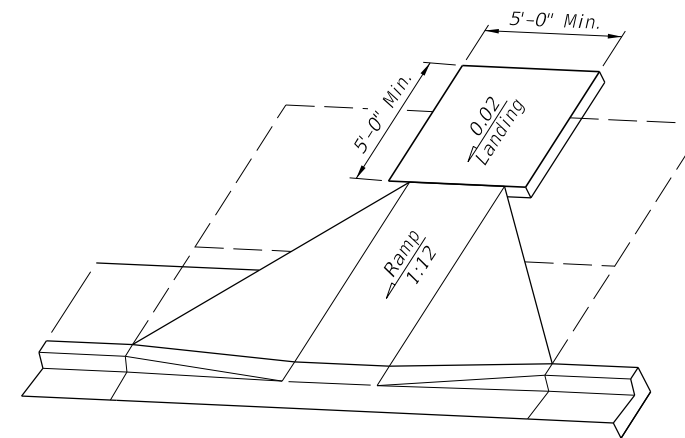
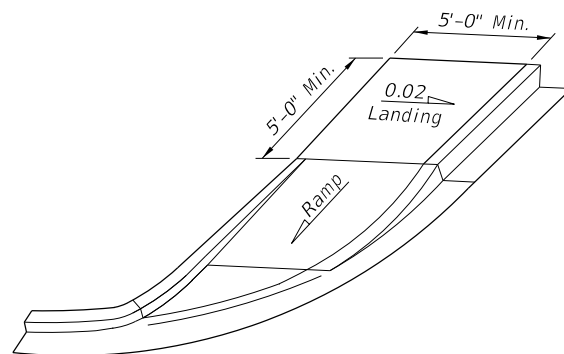
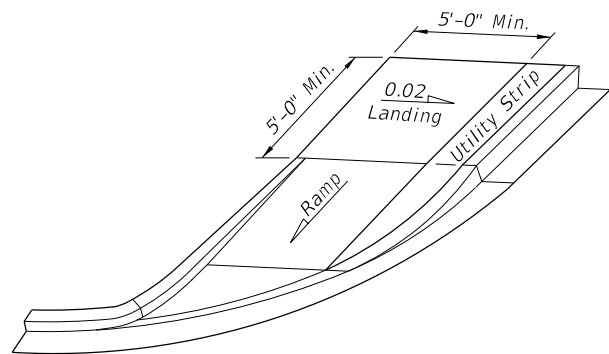

LANDINGS FOR CURB RAMPS WITHOUT SIDEWALKS

(See CR-F, CR-G & CR-K Respectively For Detectable Warning Details/Options)

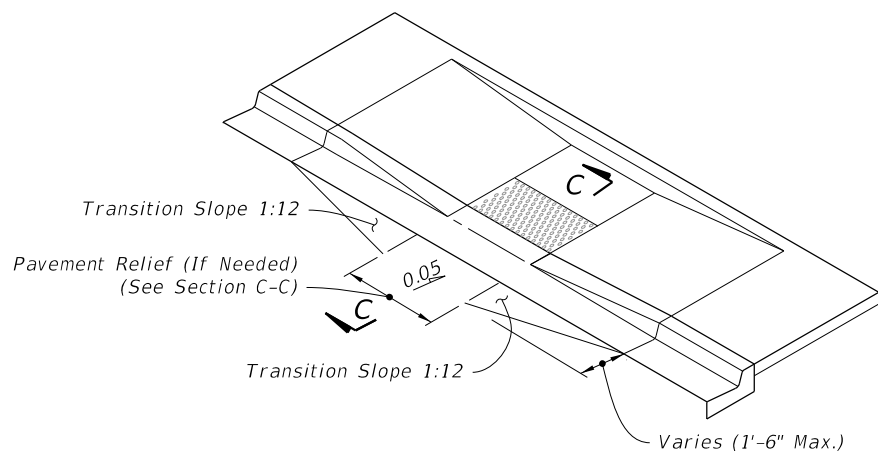

ISOMETRIC VIEW
(CR-C Shown, Other Similar)

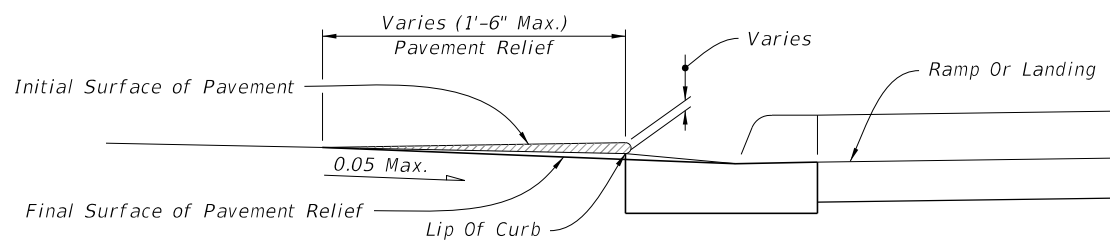

SECTION C-C

PAVEMENT RELIEF DETAILS

NOTE: Remove Elevated Pavement By Spading And Rolling, Smooth Milling, or Grinding.

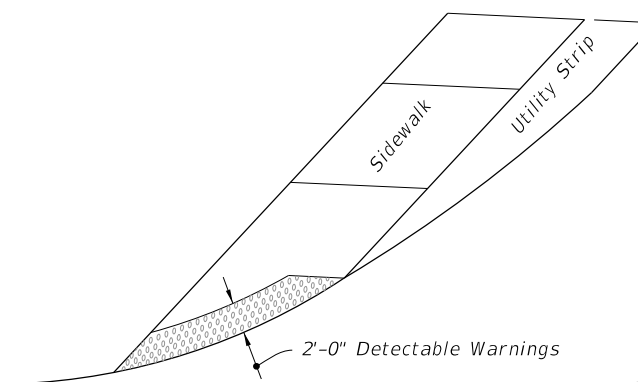

OPTION A

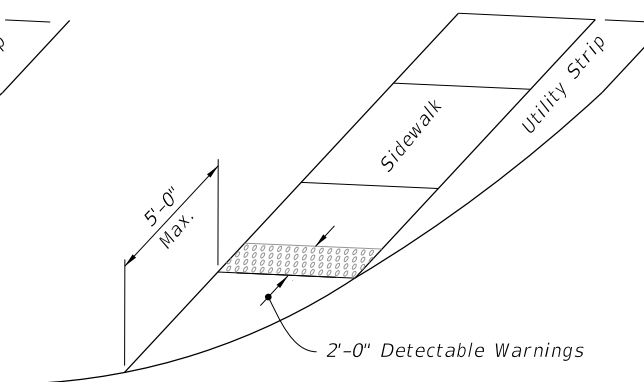

OPTION B

DETECTABLE WARNING ON FLUSH SHOULDER SIDEWALKS

CURB RAMPS WITHOUT SIDEWALKS AND FLUSH SHOULDER SIDEWALKS

9/22/2021 8:50:40 AM

LAST REVISION 11/01/20	DESCRIPTION:
---------------------------	--------------



FY 2022-23
STANDARD PLANS

DETECTABLE WARNINGS AND SIDEWALK CURB RAMPS

INDEX
522-002

SHEET
6 of 7

NOTES:

1. Where crosswalk markings are used, ramps must fall within the crosswalk limits. A clear space of 48" minimum is required at the bottom of the ramp within a marked crosswalk. If crosswalk markings are not present, a clear space of 48" minimum is required at the bottom of the ramp outside of active travel lanes.
2. Crosswalk widths and configurations vary; must conform to Index 711-001.
3. Flangeway Gap may be up to 3" for Freight-only Railways.

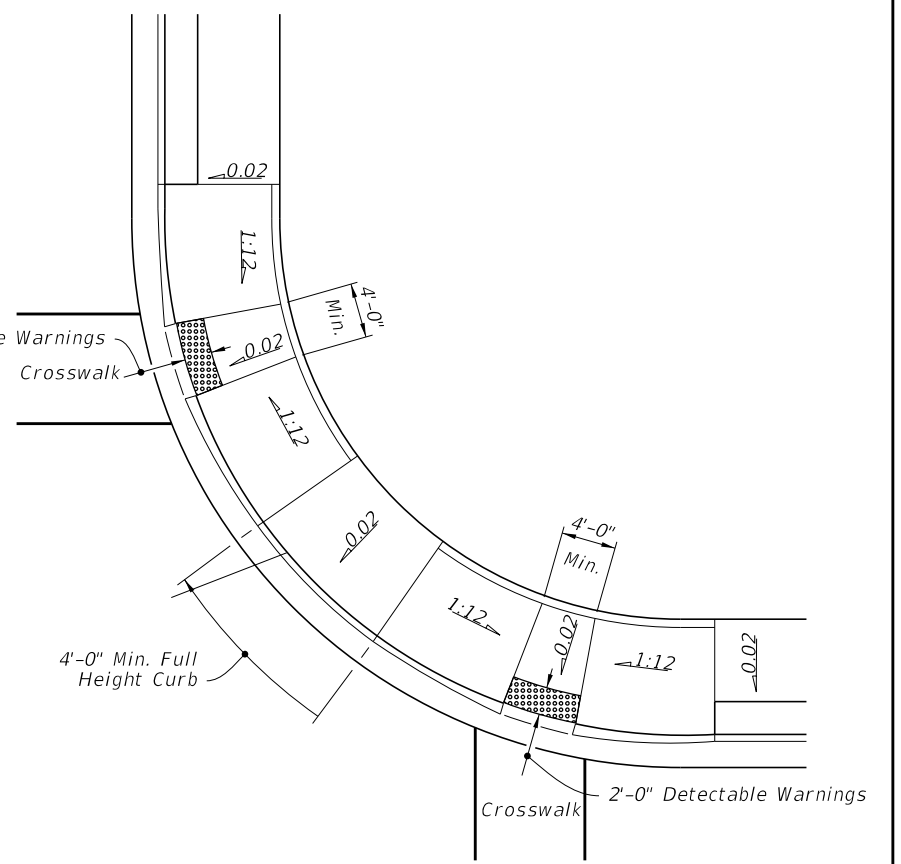
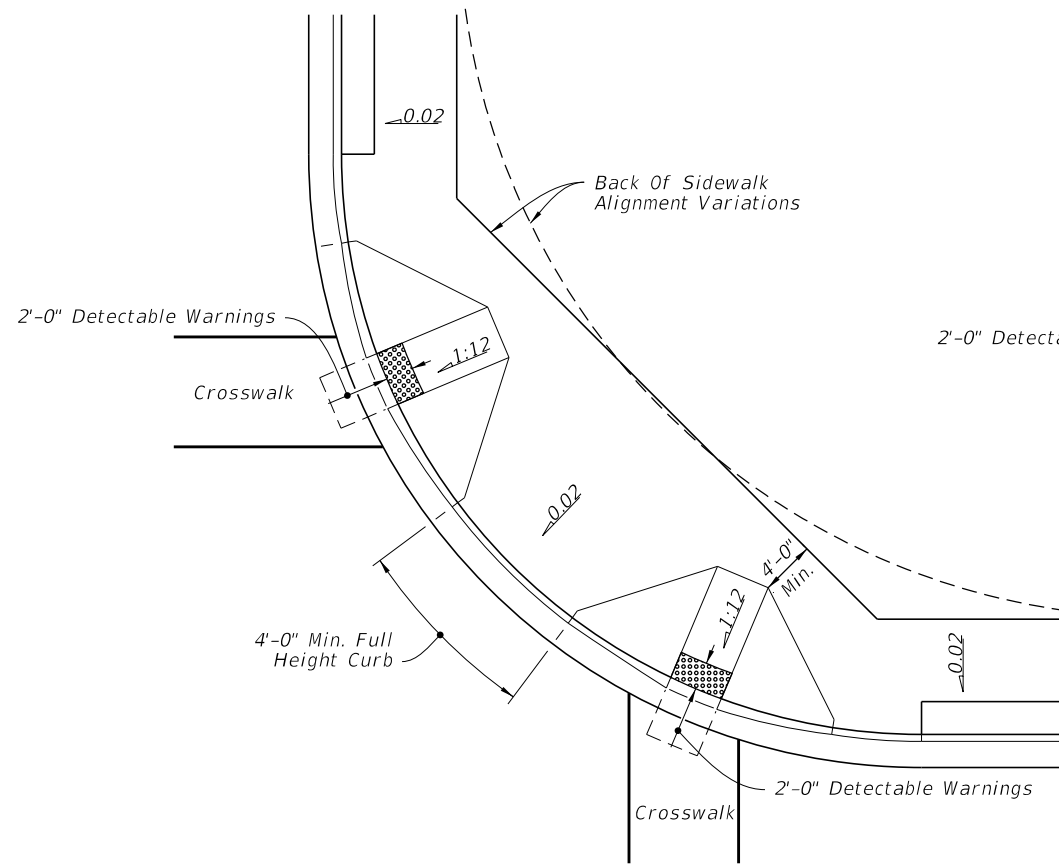
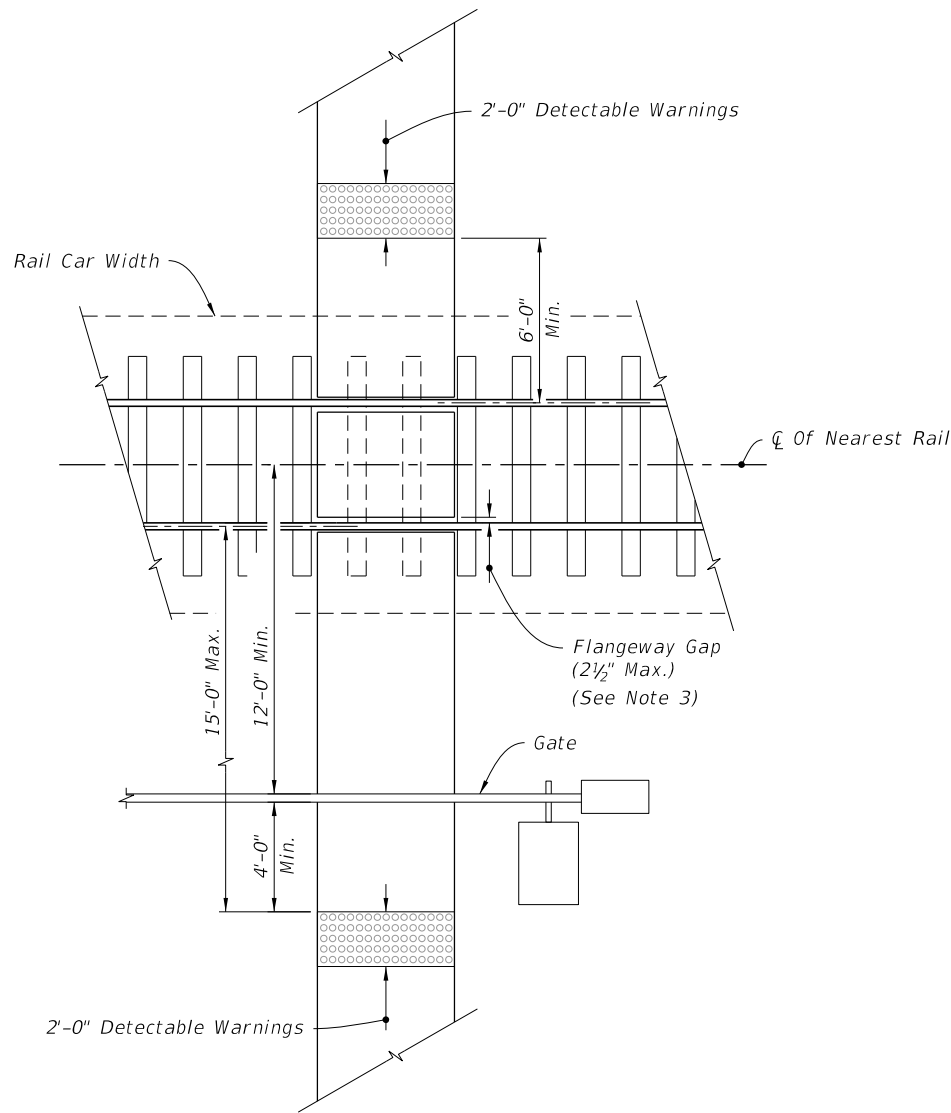

CURB RAMPS WITHIN RADIAL RETURN

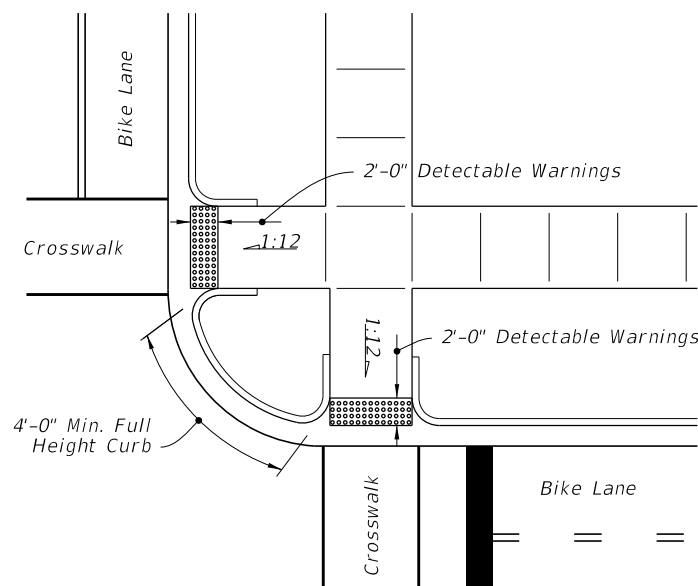

CURB RAMPS OUTSIDE RADIAL RETURN

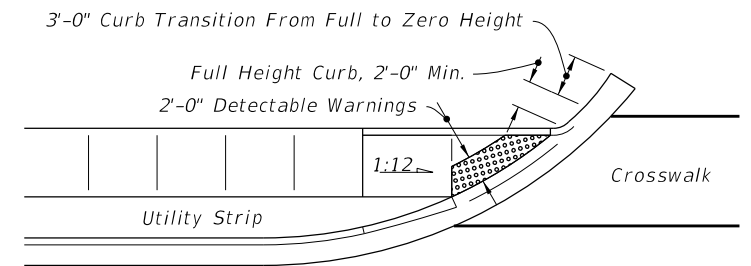

LINEAR SIDEWALK RAMPS

RAILROAD CROSSING

PLACEMENT OF SIDEWALK CURB RAMPS AT CURBED RETURNS (TYP.)

RAILROAD CROSSING AND CURB RAMPS AT CURBED RETURNS

9/22/2021 8:50:43 AM

LAST REVISION 11/01/20	DESCRIPTION:
---------------------------	--------------



FY 2022-23
STANDARD PLANS

DETECTABLE WARNINGS AND SIDEWALK CURB RAMPS

INDEX
522-002

SHEET
7 of 7