

ELEVATION

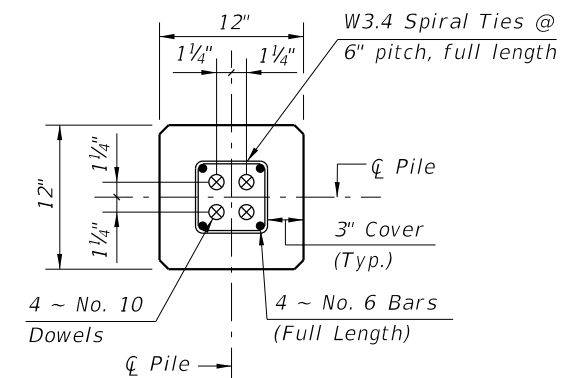

SECTION D-D
(See Non-Drivable Unforescen Reinforced Precast Pile Splice Detail)

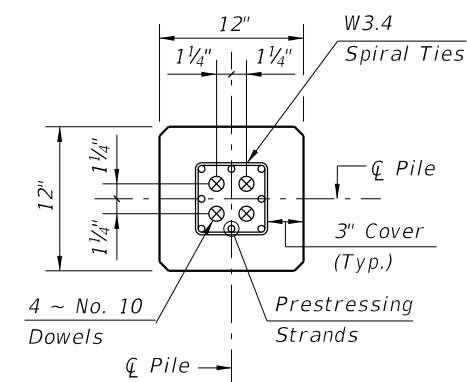

SECTION E-E
(See Drivable Unforescen Prestressed Precast Pile Splice Detail)

ALTERNATE STRAND PATTERNS

- 4 ~ 0.6" Ø, Grade 270 LRS, at 44 kips
- 8 ~ 1/2" Ø (Special), Grade 270 LRS, at 25 kips
- 8 ~ 1/2" Ø, Grade 270 LRS, at 24 kips
- 8 ~ 7/16" Ø, Grade 270 LRS, at 23 kips
- 12 ~ 3/8" Ø, Grade 270 LRS, at 16 kips

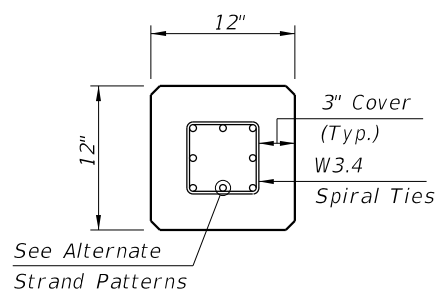

SECTION A-A

PILE SPLICE REINFORCEMENT DETAILS

NOTES:

1. Work this Index with Index 450-001 - Typical Details and Notes for Square Prestressed Concrete Piles and Index 455-002 - Square Prestressed Concrete Pile Splices.
2. Any of the given Alternate Strand Patterns may be utilized. The strands shall be located as follows:
Place one strand at each corner and place the remaining strands equally spaced between the corner strands. The total strand pattern shall be concentric with the nominal concrete section of the pile.

9/23/2021 8:37:03 AM

LAST REVISION 01/01/12	REVISION	DESCRIPTION:		FY 2022-23 STANDARD PLANS	12" SQUARE PRESTRESSED CONCRETE PILE	INDEX 455-012	SHEET 1 of 1
---------------------------	----------	--------------	--	------------------------------	--------------------------------------	------------------	-----------------