

**GENERAL NOTES:**

1. Use Class II concrete.
2. Reinforcing steel: All bars are size #4. Spacings shown are center to center. Laps to be 1'-5" minimum. Cover is 2" except as noted. Square welded wire fabric (two cages max.) having an equivalent cross sectional area (0.20 sq. in.) may be substituted for bar reinforcement.
3. Endwall may be cast in place or precast concrete. Construct precast units to dimensions shown, or as shown in approved shop drawings. Use Index 425-001 for opening and grouting details.
4. Quantities shown are for estimating purposes only.

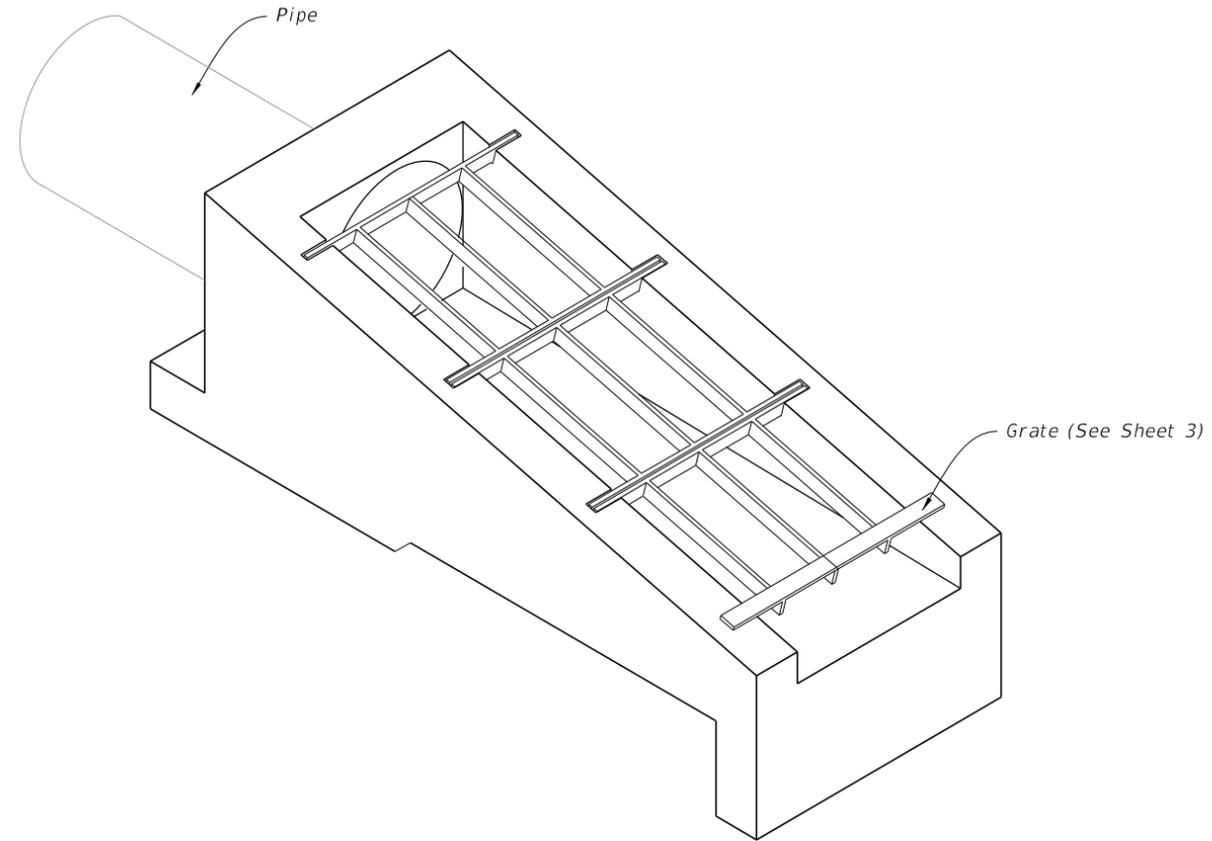
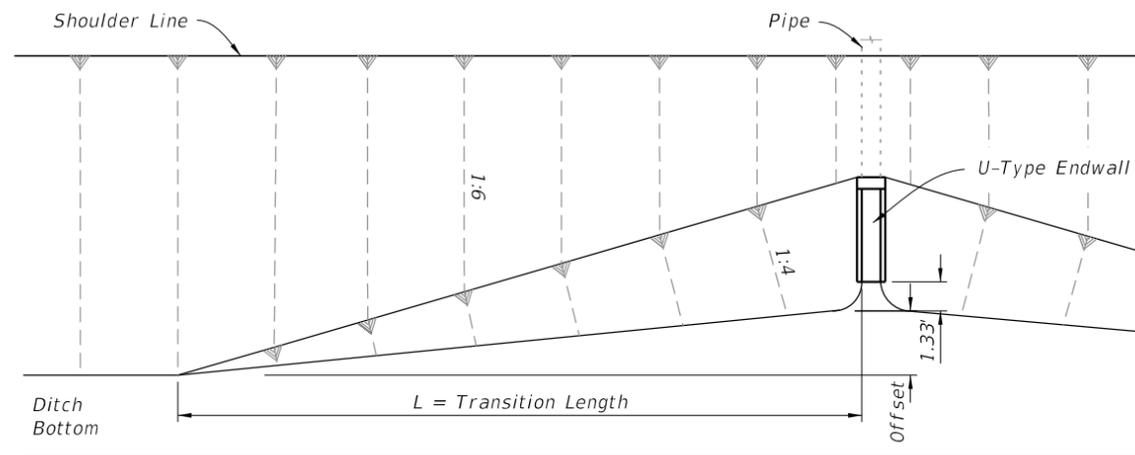

TABLE OF CONTENTS:	
Sheet	Description
1	General Notes and Contents
2	Dimensional and Reinforcing Details
3	Type 1 and Type 2 Grate Details

U-TYPE CONCRETE ENDWALLS 15" TO 30" PIPES WITH GRATES  
(24" Pipe Shown)



Slope	Pipe Dia.	Offset (Ft.)	L (Ft.)
1:4	15"	4.2	42
	18"	4.8	48
	24"	5.8	58
	30"	6.9	69

FRONT SLOPE TRANSITION AT ENDWALL

9/21/2021 1:30:36 PM

LAST REVISION 11/01/21	DESCRIPTION:
---------------------------	--------------



FY 2022-23  
STANDARD PLANS

U-TYPE CONCRETE ENDWALLS  
15" TO 30" PIPES WITH GRATES

INDEX  
430-010

SHEET  
1 of 3

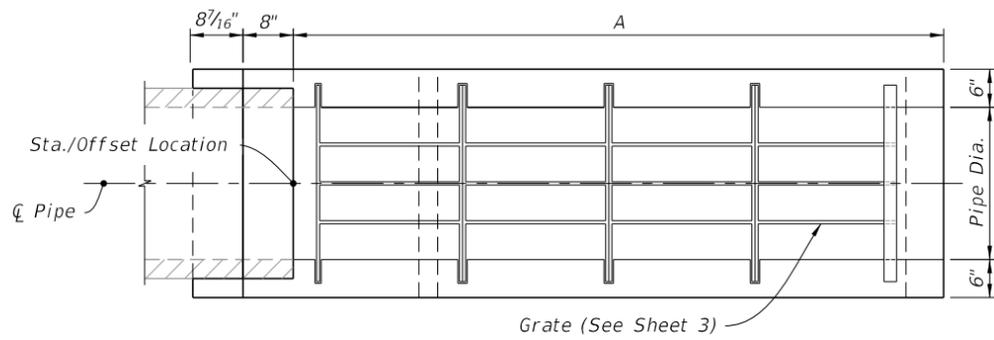

PLAN

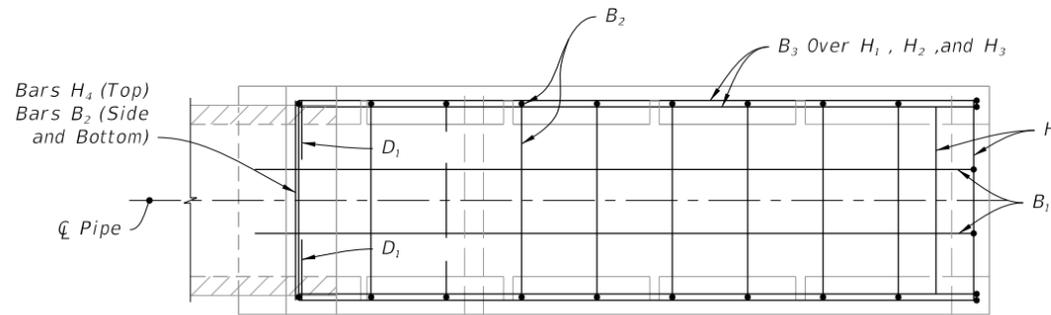

PLAN

**LEGEND:**  
 H = Horizontal Bars  
 V = Vertical Bars  
 B = Bent Bars  
 D = Dowels or Diagonal Bars

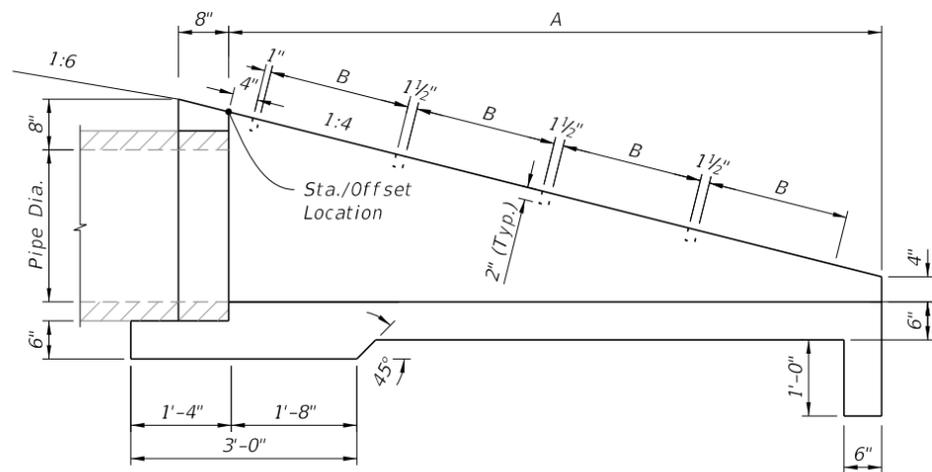

ELEVATION

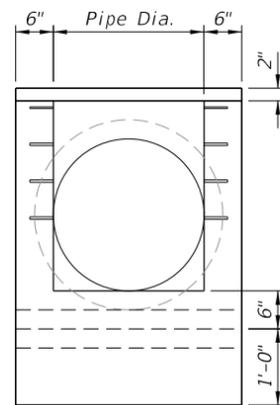

END VIEW

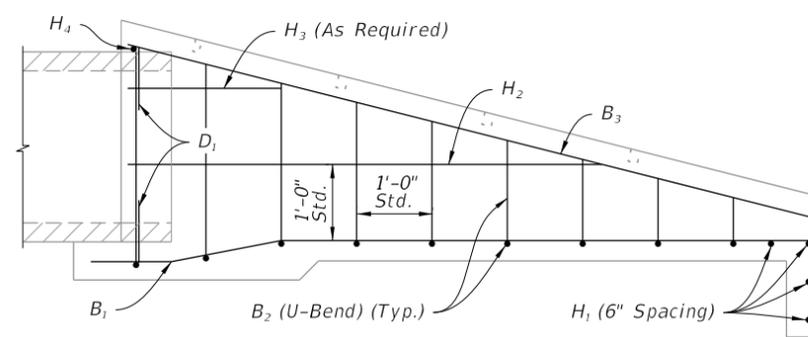

ELEVATION

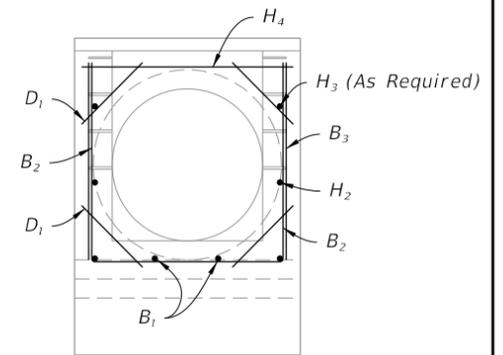

END VIEW

DIMENSIONAL DETAIL

REINFORCING DETAIL

	Pipe Dia.	A (Ft.)	B (Ft.)	Class II Conc. (CY)	Reinf. Steel (lbs.)
Slope 1:4	15"	5.67	2.38	0.85	56
	18"	6.67	1.875	1.01	73
	24"	8.67	1.875	1.65	97
	30"	10.67	1.875	2.33	129

9/21/2021 1:30:36 PM

LAST REVISION 11/01/21	DESCRIPTION:
---------------------------	--------------



FY 2022-23  
STANDARD PLANS

U-TYPE CONCRETE ENDWALLS  
15" TO 30" PIPES WITH GRATES

INDEX  
430-010

SHEET  
2 of 3

DIMENSIONAL AND REINFORCING DETAILS

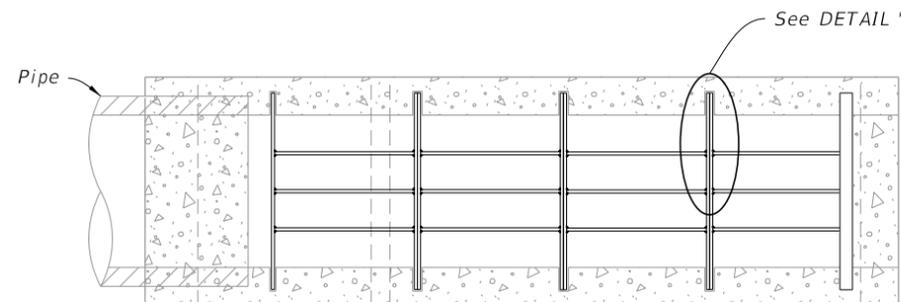

PLAN

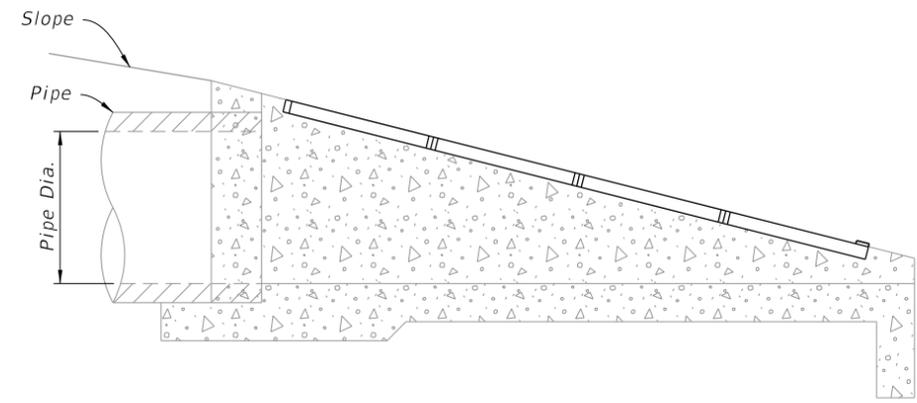

ELEVATION

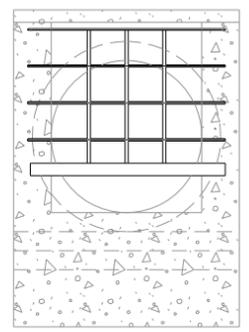

END VIEW

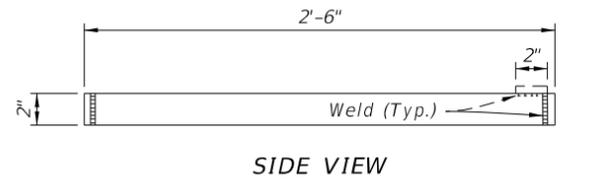

SIDE VIEW

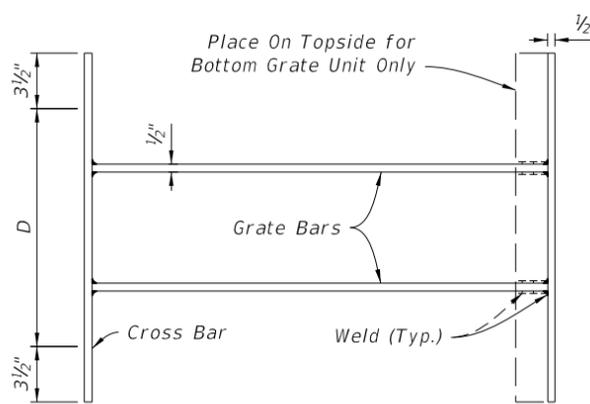

TOP VIEW  
TYPE 1

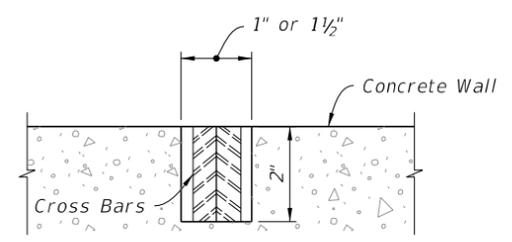

SECTION A-A

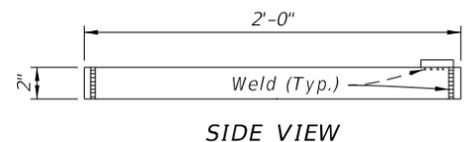

SIDE VIEW

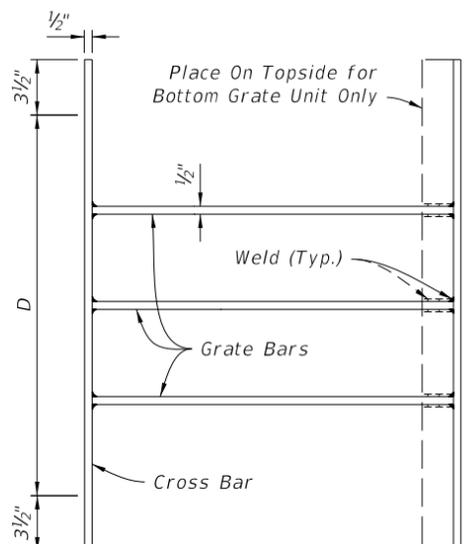

TOP VIEW  
TYPE 2

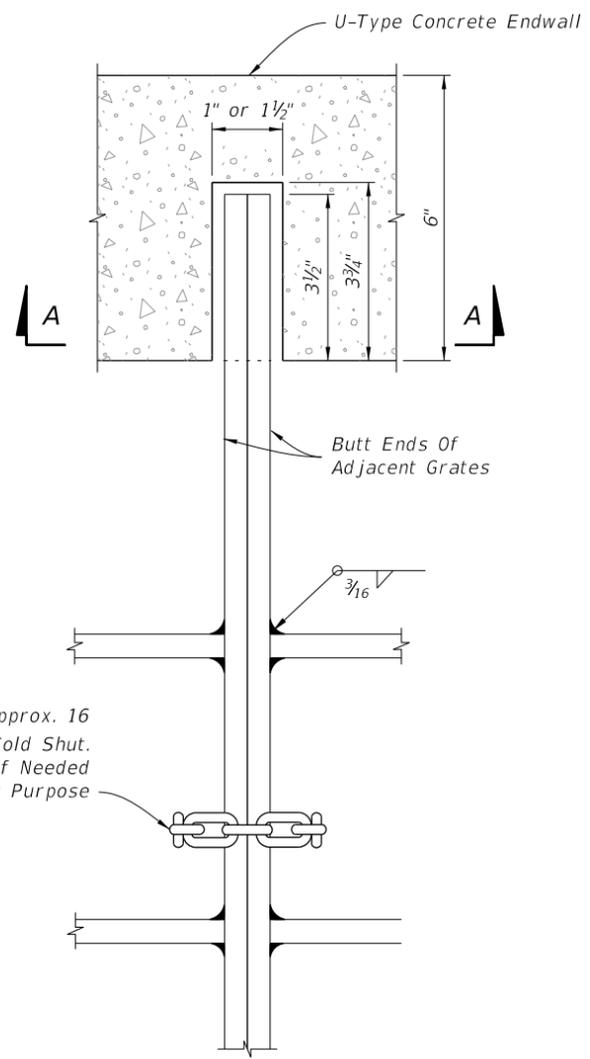

GRATE, SEAT, WELD & CHAIN DETAIL

**NOTES:**

1. Install grate bars evenly spaced across dimension D.
2. All bars and grate bars are 1/2" x 2".

TABLE 3 NUMBER OF GRATE BARS AND GRATES REQUIRED						
Pipe Dia. D	Grate Bars Req'd.		Grate Wt. (lbs.)	Grate Req'd.		Total Grate Wt. (lbs.)
	Type No. 1	Type No. 2		Type No. 1	Type No. 2	
15"	2	0	28.93	2	0	57.86
18"	0	3	33.69	0	3	101.08
24"	0	4	43.63	0	4	174.52
30"	0	5	53.55	0	5	267.75

TYPE 1 AND TYPE 2 GRATE DETAILS

DETAIL "A"

**TYPE 1 AND TYPE 2 GRATE DETAILS**

9/21/2021 1:30:37 PM

LAST REVISION 11/01/19	DESCRIPTION:
---------------------------	--------------

**FY 2022-23  
STANDARD PLANS**

**U-TYPE CONCRETE ENDWALLS  
15" TO 30" PIPES WITH GRATES**

INDEX 430-010	SHEET 3 of 3
------------------	-----------------