

GENERAL NOTES:

1. Work this Index with Index 425-001 and Index 425-010.
2. All reinforcing is Grade 60 bars with 2" min. cover unless otherwise noted.
See Index 425-001 for equivalent area of welded wire fabric. Cut or bend bars out of way of pipe to clear pipe 1½".
3. Chamfer all exposed edges and corners ¾" or tool to ¼" radius.
4. Dimensions are for both precast and cast-in-place inlets unless otherwise noted.

TABLE OF CONTENTS:	
Sheet	Description
1	General Notes and Contents
2	Dimensional and Reinforcing Details
3	Steel Grate Details
4	Alternate A Structure Bottom - Top Slab Details

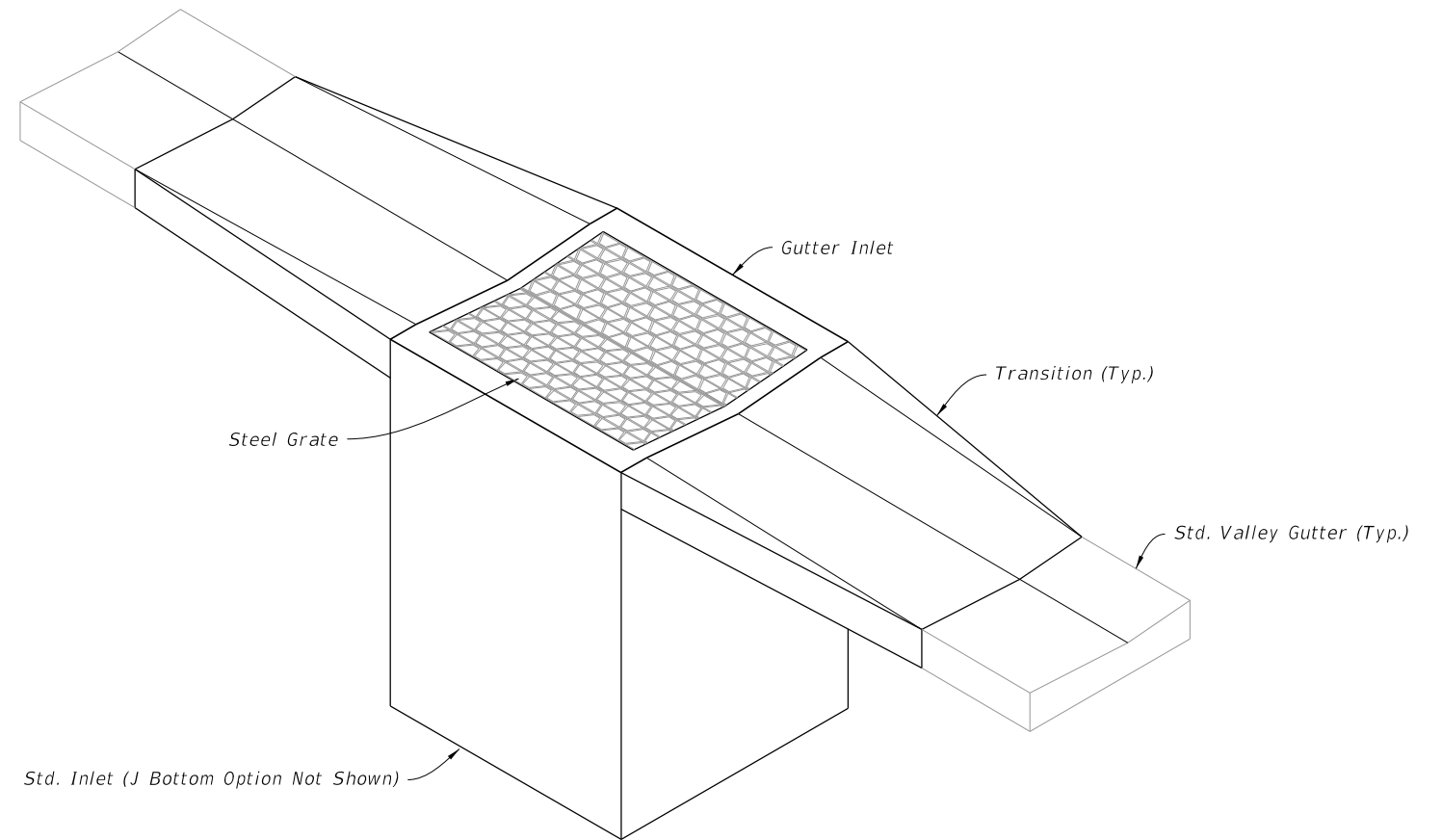

===== GUTTER INLET TYPE V =====
(Pipe Opening Not Shown)

9/21/2021 1:20:23 PM

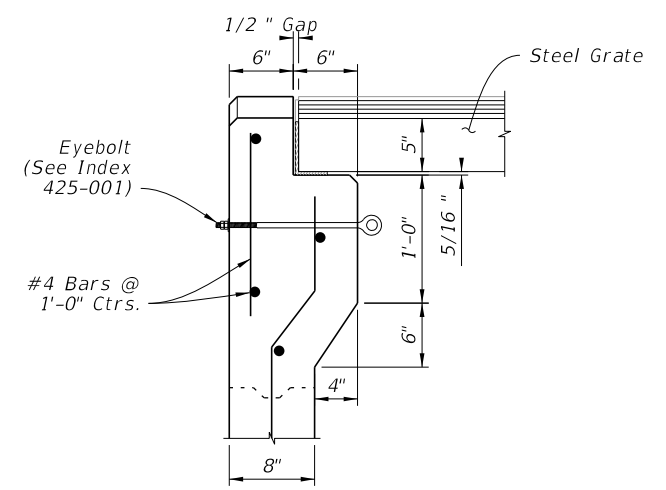
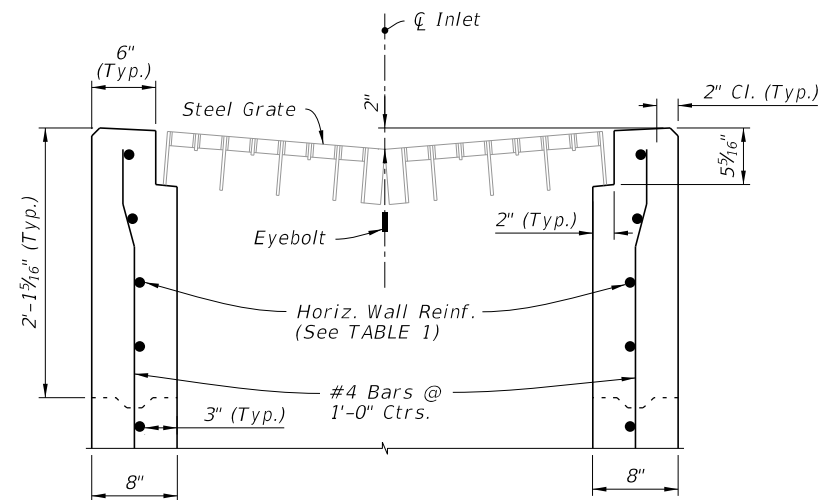
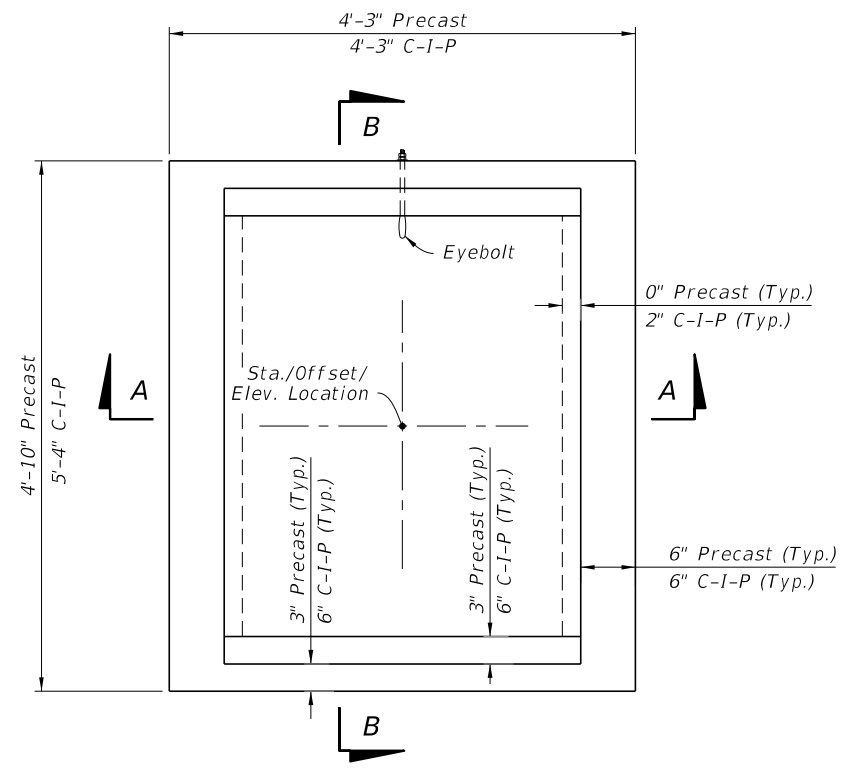

DETAIL "A"

DETAIL "B"

CAST-IN-PLACE OPTION

PLAN

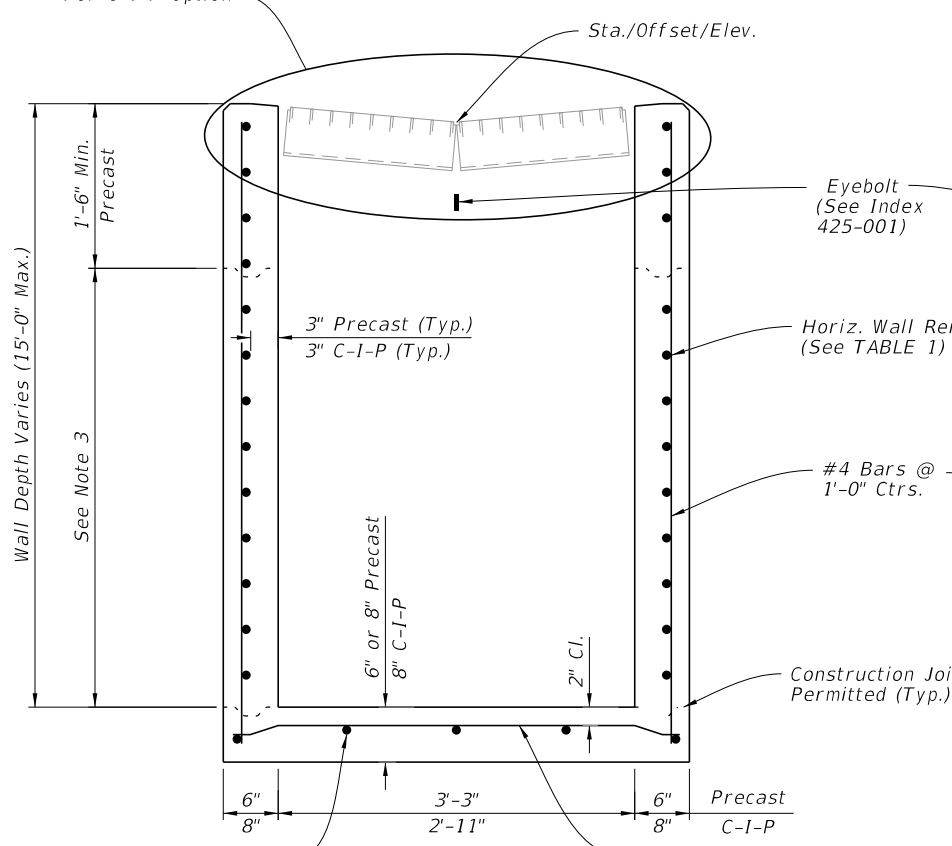

SECTION A-A
(Pipe Opening Not Shown)

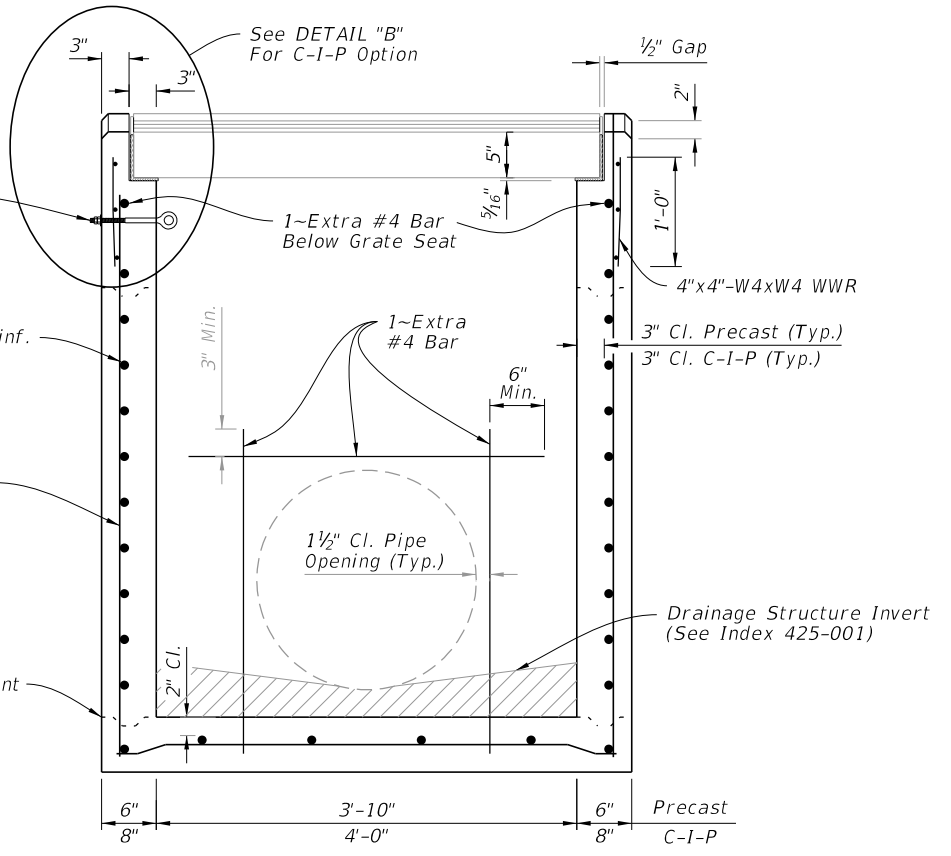

SECTION B-B
(Pipe Opening Shown)

TABLE 1
HORIZONTAL WALL REINFORCING SCHEDULE

WALL DEPTH	SCHEDULE	AREA (in. ² /ft.)	MAX. SPACING	
			BARS	WWR
0' - 5'	A12	0.20	12"	8"
5' - 9'	A6	0.20	6"	5"
9' - 12'	A4	0.20	4"	3"
9' - 15'	B5.5	0.24	5 1/2"	5"

NOTES:

1. Plan View: Grate, Concrete Ditch Pavement, and Sod not shown on structure detail.
2. Precast Shown, Cast-In-Place (C-I-P) similar.
3. Construction joints permitted between these limits. See Index 425-001 for minimum dimensions.

DIMENSIONAL AND REINFORCING DETAILS

DIMENSIONAL AND REINFORCING DETAILS

9/21/2021 1:20:24 PM

LAST REVISION 11/01/20	DESCRIPTION:
---------------------------	--------------



**FY 2022-23
STANDARD PLANS**

GUTTER INLET TYPE V

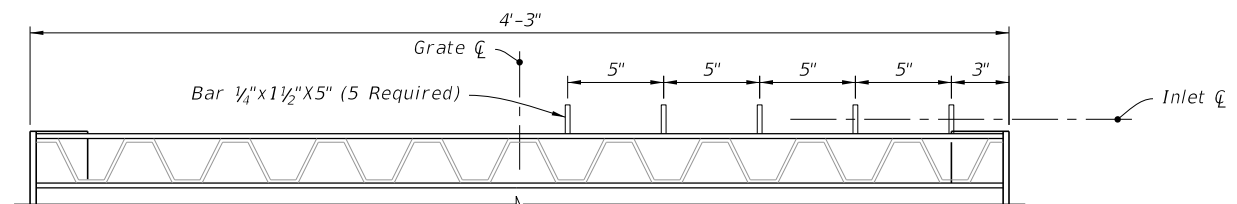
INDEX 425-041	SHEET 2 of 4
------------------	-----------------

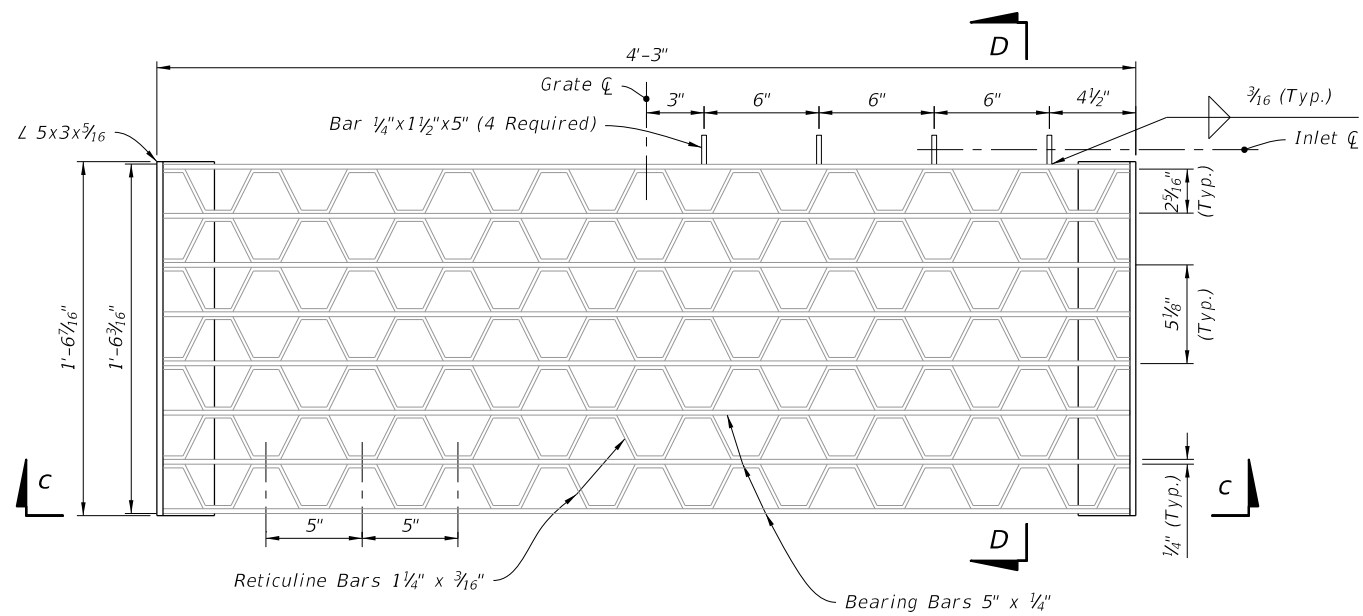

OPTIONAL BAR SPACING



PLAN

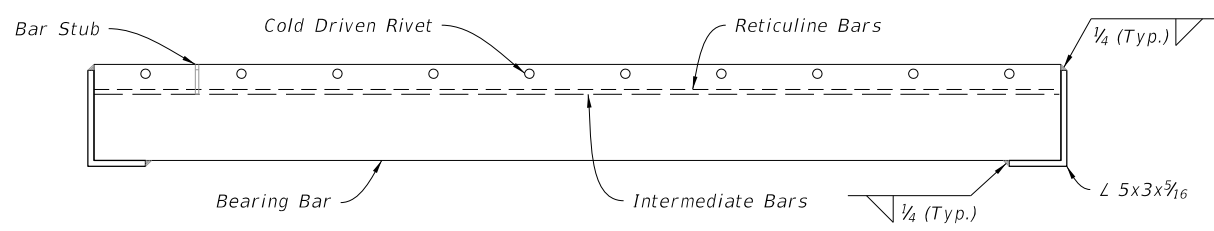

SECTION C-C

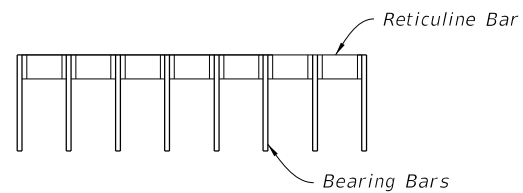

SECTION D-D

RETICULATE GRATE DETAIL

(Two Grates Required per Inlet)

STEEL GRATE DETAILS

9/21/2021 1:20:25 PM

LAST REVISION 11/01/20	DESCRIPTION:
---------------------------	--------------



FY 2022-23
STANDARD PLANS

GUTTER INLET TYPE V

INDEX
425-041

SHEET
3 of 4

9/21/2021 1:20:26 PM

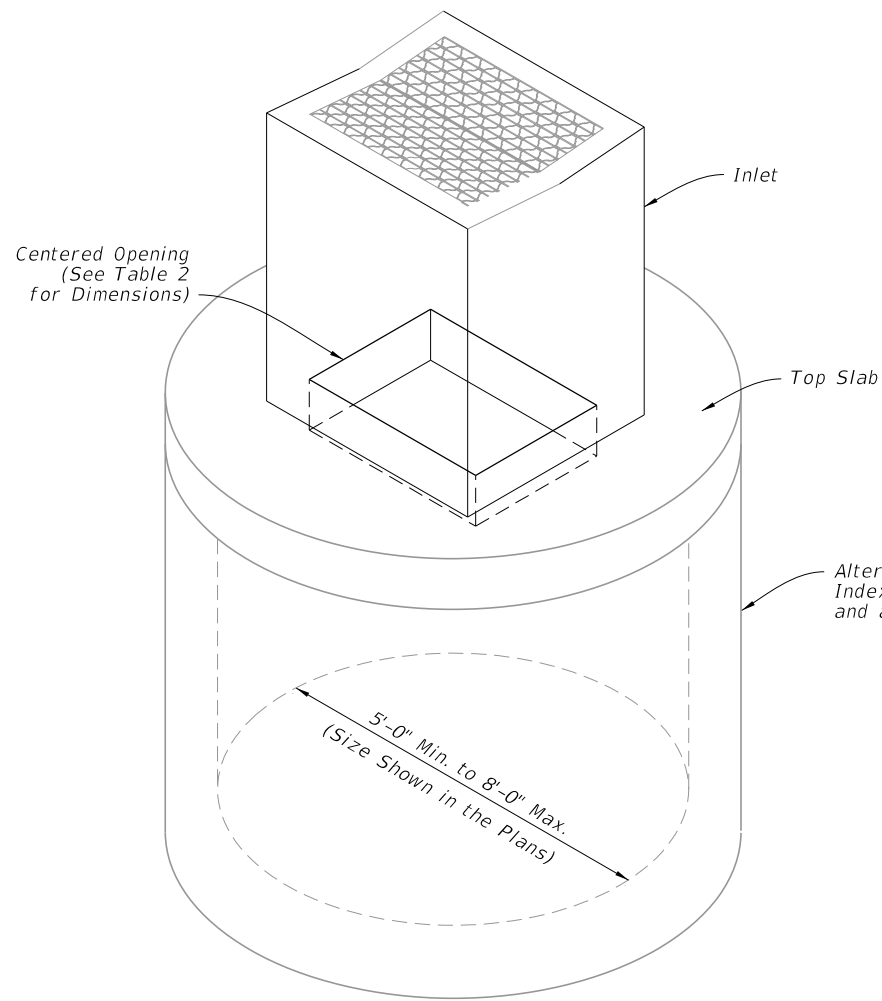

DIAMETER	OPENING SIZE	
	Min.	Max.
5'-0" to 8'-0"	2'-11" x 4'-0"	3'-3" x 3'-10"

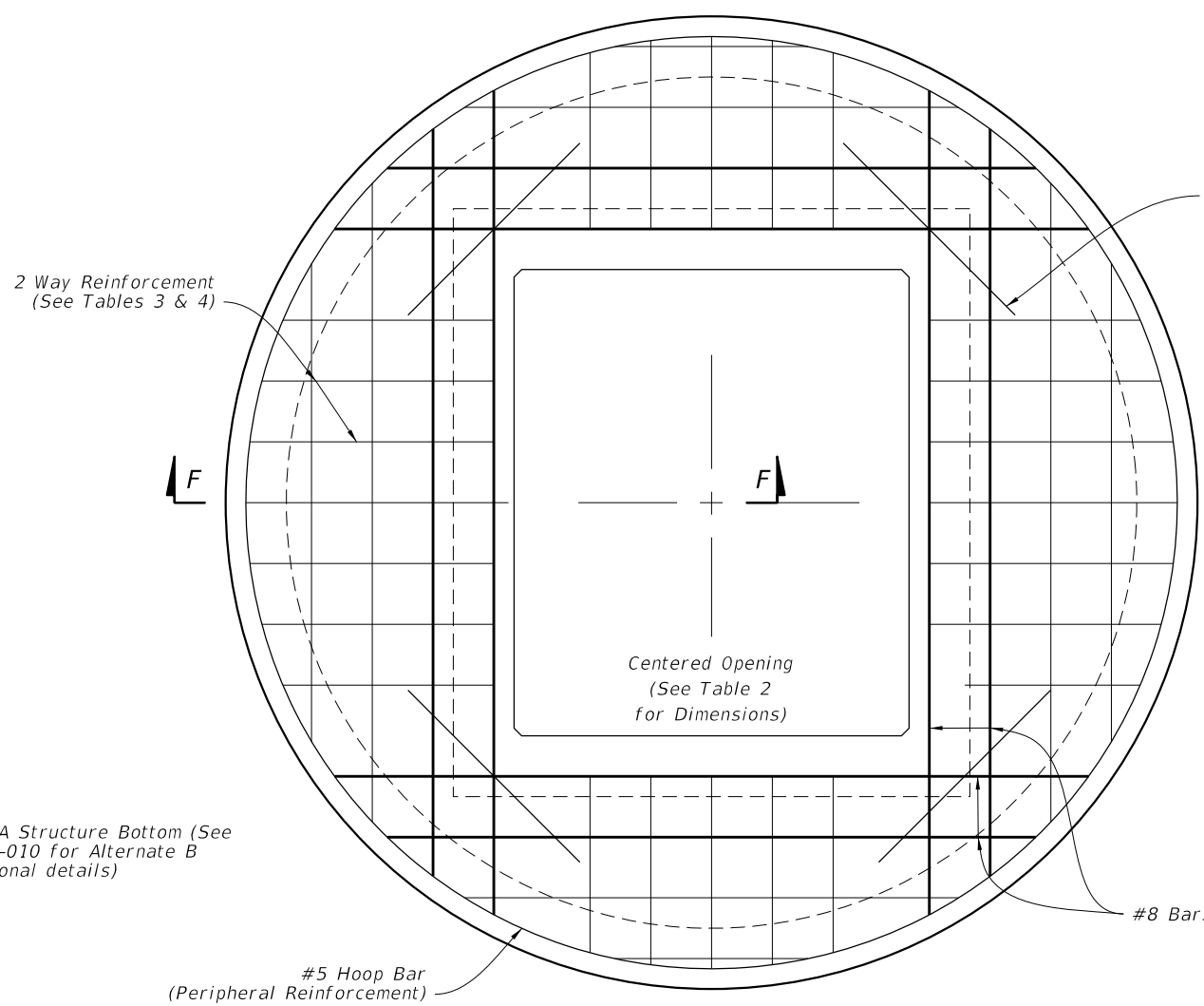

SCHEDULE	GRADE 60 (BAR) OR 65 KSI & 70 KSI (WIRE FABRIC) In. ² /ft.
A	0.20
B	0.24
C	0.37
D	0.53
E	0.73
F	1.06
G	1.45

STRUCTURE DEPTH	SLAB THICKNESS	REINFORCING (2 WAY) SCHEDULE
SIZE: 5'-0"		
≥0.5' < 30'	9½"	C
30' < 40'	9½"	D
SIZE: 6'-0"		
0.5' < 8'	9½"	B
8' < 18'	9½"	C
18' < 30'	9½"	D
30' < 37'	9½"	E
37' < 40'	9½"	G
SIZE: 8'-0"		
≥0.5' < 9'	11½"	C
9' < 15'	11½"	D
15' < 23'	11½"	E
23' < 33'	11½"	E
33' < 40'	11½"	G

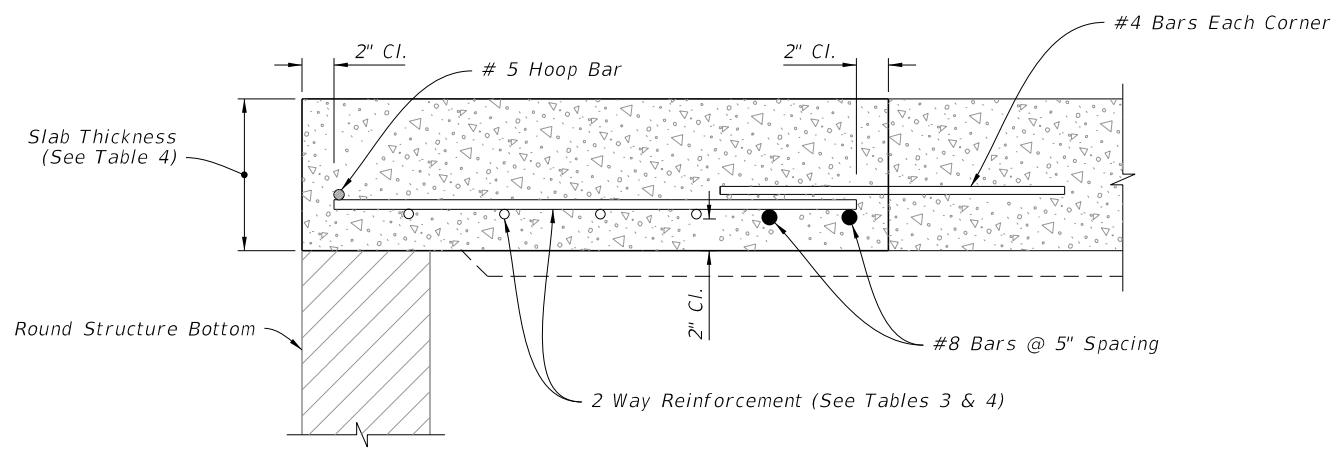

ISOMETRIC VIEW

TOP SLAB REINFORCEMENT DETAILS

ALTERNATE A STRUCTURE BOTTOM - TOP SLAB DETAILS

LAST REVISION	DESCRIPTION:
11/01/20	



FY 2022-23
STANDARD PLANS

GUTTER INLET TYPE V

INDEX
425-041

SHEET
4 of 4