

**GENERAL NOTES:**

This Index is only applicable to the current FDOT inventory of temporary bridge components which are manufactured in accordance with Acrow Series 700XS three Lane 24',36', and 42' widths. Asphalt Overlay is required on the Bridge deck, see Sheet 2 for details.

Work this Index with Index 102-210, 102-220 and 102-230.

**STRUCTURAL STEEL:**

Steel Plates shall be ASTM A709 Grade 36.

**EXPANSION BEARINGS:**

Inspect the PTFE (Teflon) layer and stainless steel plate prior to installation. Do not use bearings that have a severely damaged or unbonded PTFE layer. Clean PTFE of all grit and grime prior to installation. Clean Stainless steel plate of all grit and grime prior to installation and finish to a smooth buffed surface.

**DISTRIBUTION BEAMS:**

Distribution beam stops restraining the distribution beams may be lengthened or shortened to center the distributing beam bearing on the cap beam. The longitudinal stops are to bear on the distributing beam end frame.

**EXPANSION JOINT SETTINGS:**

Install the expansion joint considering the total continuous bridge length, location of fixed bearings and ambient temperature at the time of installation, assume a 2" expansion joint opening at 70 degrees F, (Expansion joint depends on span/bridge length and configuration).

**STORAGE FACILITY:**

Contact  
 FDOT Statewide Aluminum Shop  
 2590 Camp Rd.  
 Oviedo, Fl.  
 407-278-2727  
 For shipping weights and dimensions of Temporary Bridge elements. Contractor to coordinate with Storage Facility and Acrow to obtain required parts list. Shipping weights and dimensions of other bridge components can be referenced in "Acrow Panel Bridging, Series 700XS, Technical Handbook".

**APPROACH TRAFFIC RAILING NOTES:**

See Index 536-001 for component details, geometric layouts and associated notes not fully detailed herein.

**CONCRETE:** Concrete for Transition Blocks shall be Class II (Bridge Deck).

**THRIE-BEAM PANEL:** Steel Thrie-Beam Elements shall meet the requirements of AASHTO M180, Type II (Zinc coated).

**BOLTS, NUTS AND WASHERS:**

Bolts, nuts and round washers shall be in accordance with AASHTO M180. Plate Washers shall be in accordance with ASTM A36 or ASTM A709 Grade 36. Do not drill Temporary Bridge components to attach Guardrail. Guardrail Bolts shall be placed between Truss members as shown in Index 102-240.

**COATINGS:** All Nuts, Bolts, Anchors, Washers and Backer Plates shall be hot-dip galvanized in accordance with the Specifications.

**WOOD BLOCKS:** All wood blocks, including required wedge shaped blocks shall be Pressure Treated Lumber in accordance with Specifications Section 955. Bolt holes in blocks to be centered ( $\pm 1/4"$ ).

**PAYMENT:**

Temporary Detour Bridge is to be paid for under Contract Unit Price for Special Detour. If a temporary bridge system other than that shown herein is used, the Contractor is responsible for renting or purchasing their own system. Payment for Temporary Guardrail work and Transition Block will be made under Pay Item Temporary Guardrail, LF.

Furnish and install Bridge Thrie-Beam Panels and all associated hardware as shown. Payment will be made with the Temporary Detour Bridge under the Pay Item Special Detour, LS. Turn over Bridge Thrie-Beam Panels and all associated hardware to the Department with the Detour Bridge components per Specifications Section 102-6.

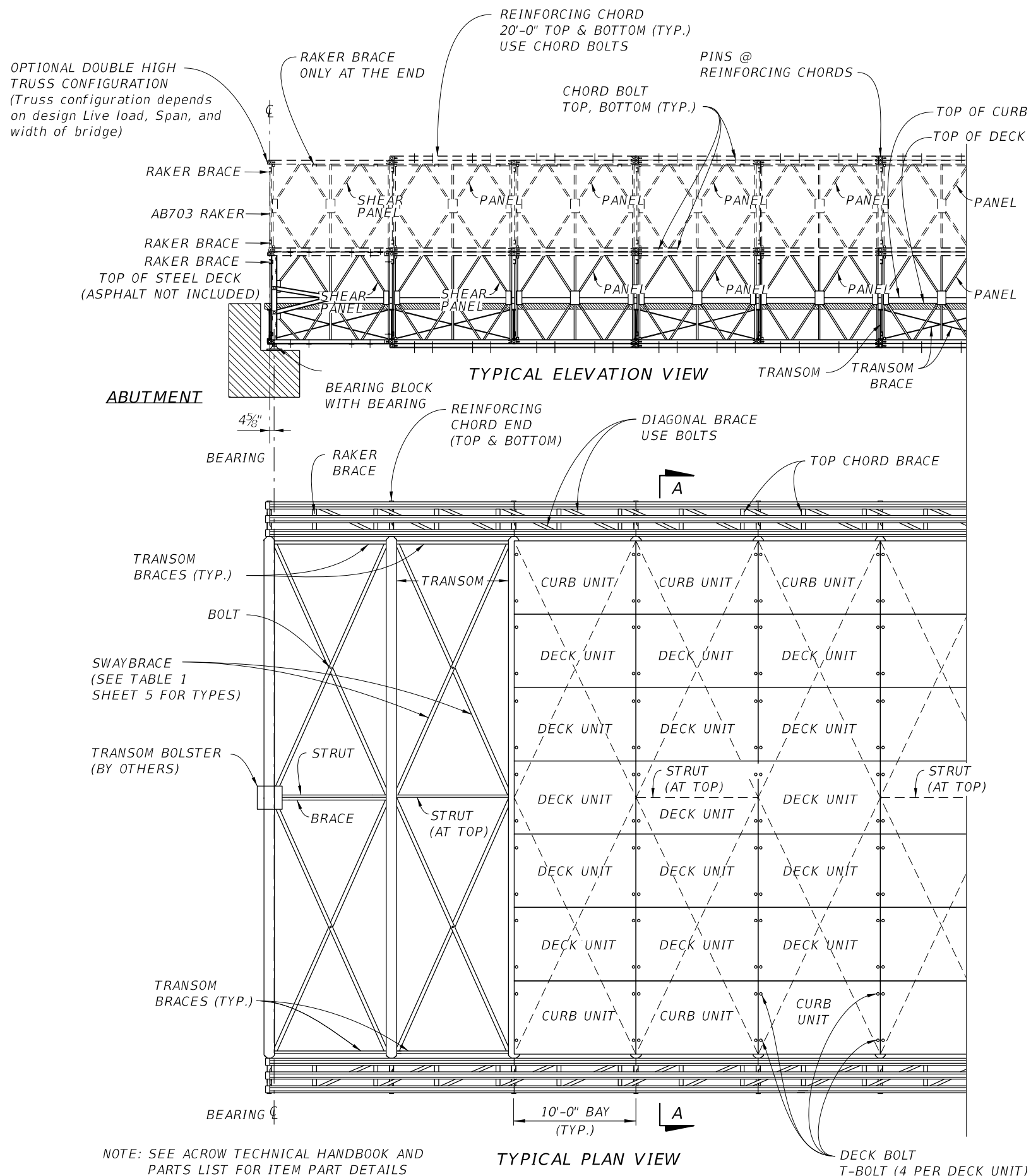

9/23/2021 8:00:54 AM

LAST REVISION 11/01/20	REVISION	DESCRIPTION:	 FY 2022-23 STANDARD PLANS	TEMPORARY ACROW 700XS SERIES DETOUR BRIDGE GENERAL NOTE AND DETAILS	INDEX 102-201	SHEET 1 of 5
---------------------------	----------	--------------	--	--	------------------	-----------------

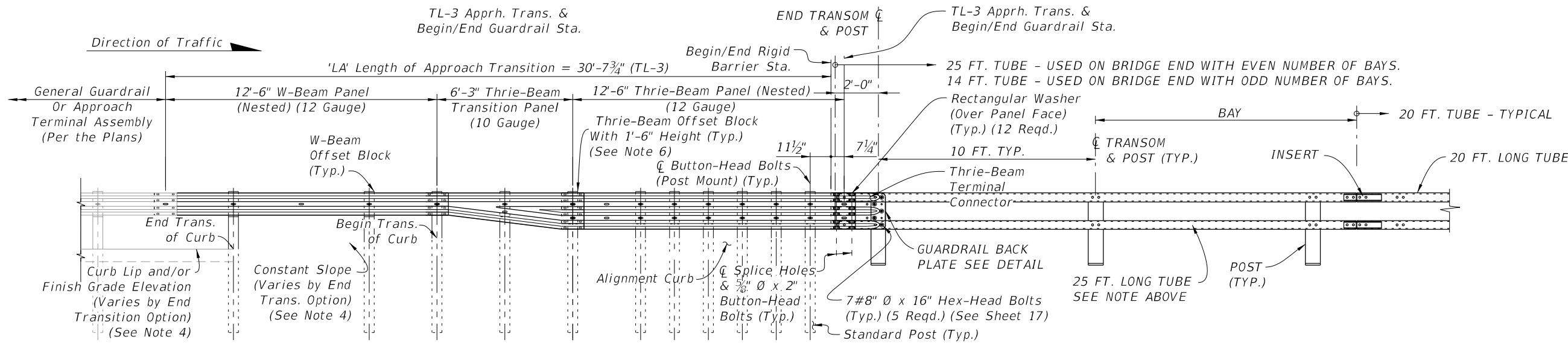

TL-3 APPROACH TRANSITION INSTALLED ELEVATION

GUARDRAIL LAYOUT - ELEVATION

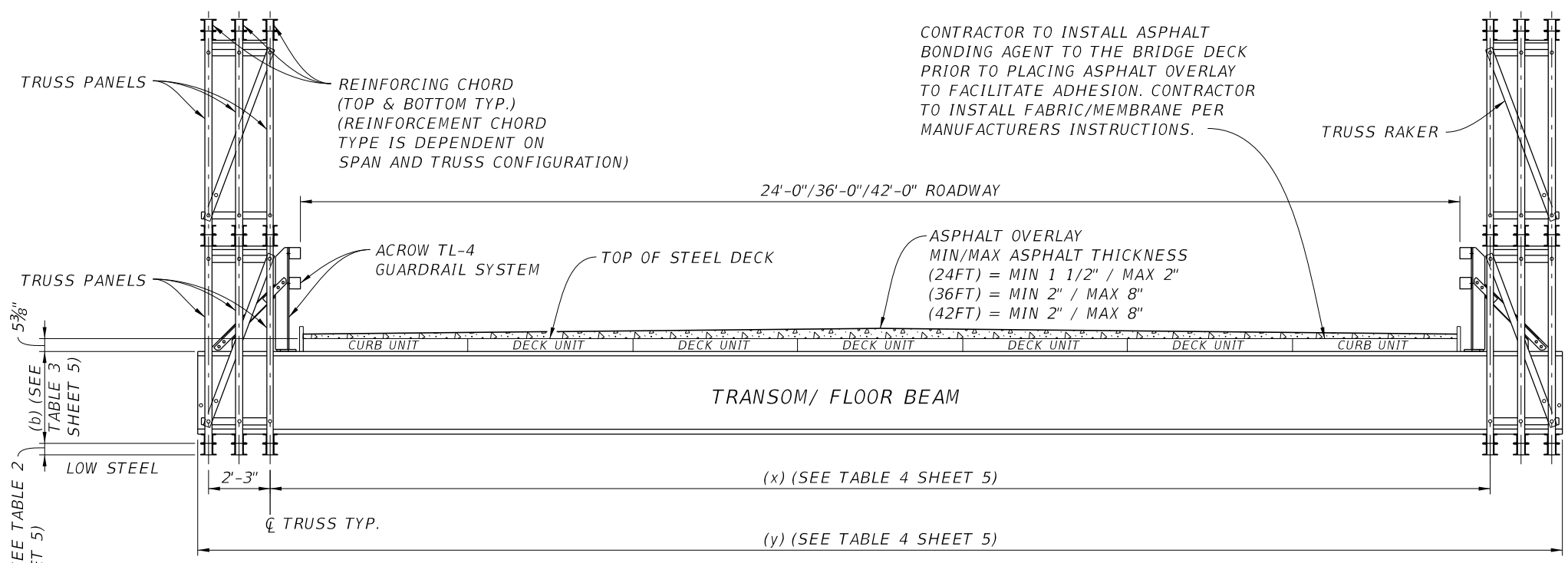

SECTION A-A  
(Double High Truss shown, Single High Truss Similar)

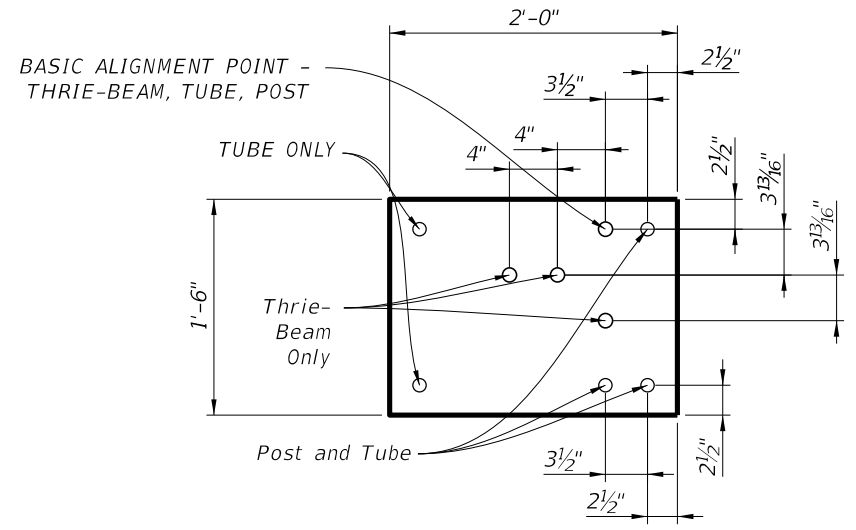

GUARDRAIL BACK PLATE DETAIL

NOTE: SEE ACROW TECHNICAL HANDBOOK AND PARTS LIST FOR ITEM NUMBER DETAILS.

9/23/2021 8:00:55 AM

LAST REVISION 11/01/20	REVISION	DESCRIPTION:		FY 2022-23 STANDARD PLANS	TEMPORARY ACROW SERIES 700XS DETOUR BRIDGE BEAM AND GUARDRAIL DETAILS	INDEX 102-201	SHEET 2 of 5
---------------------------	----------	--------------	--	------------------------------	--	------------------	-----------------

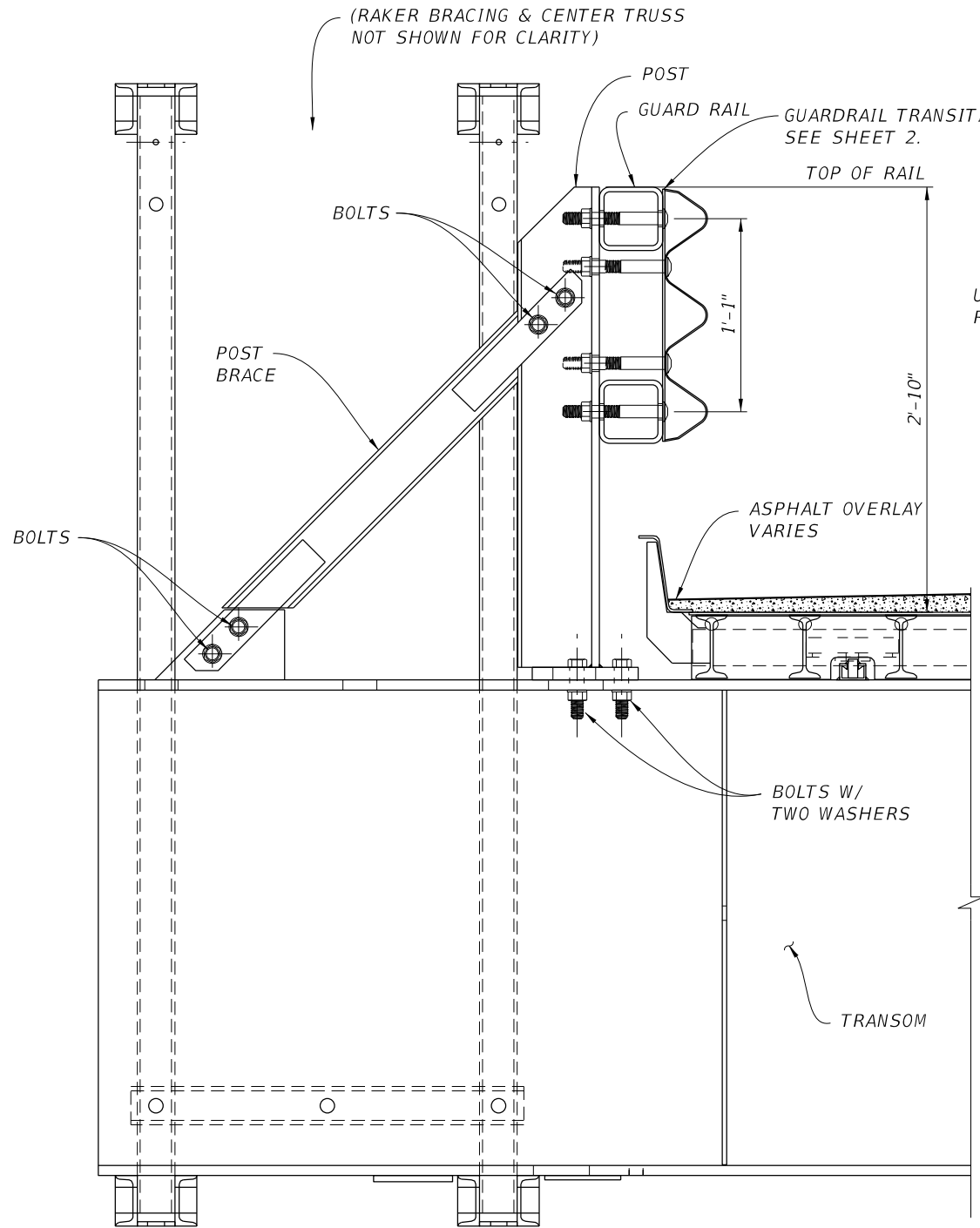

TYPICAL RAILING POST CONNECTION DETAIL

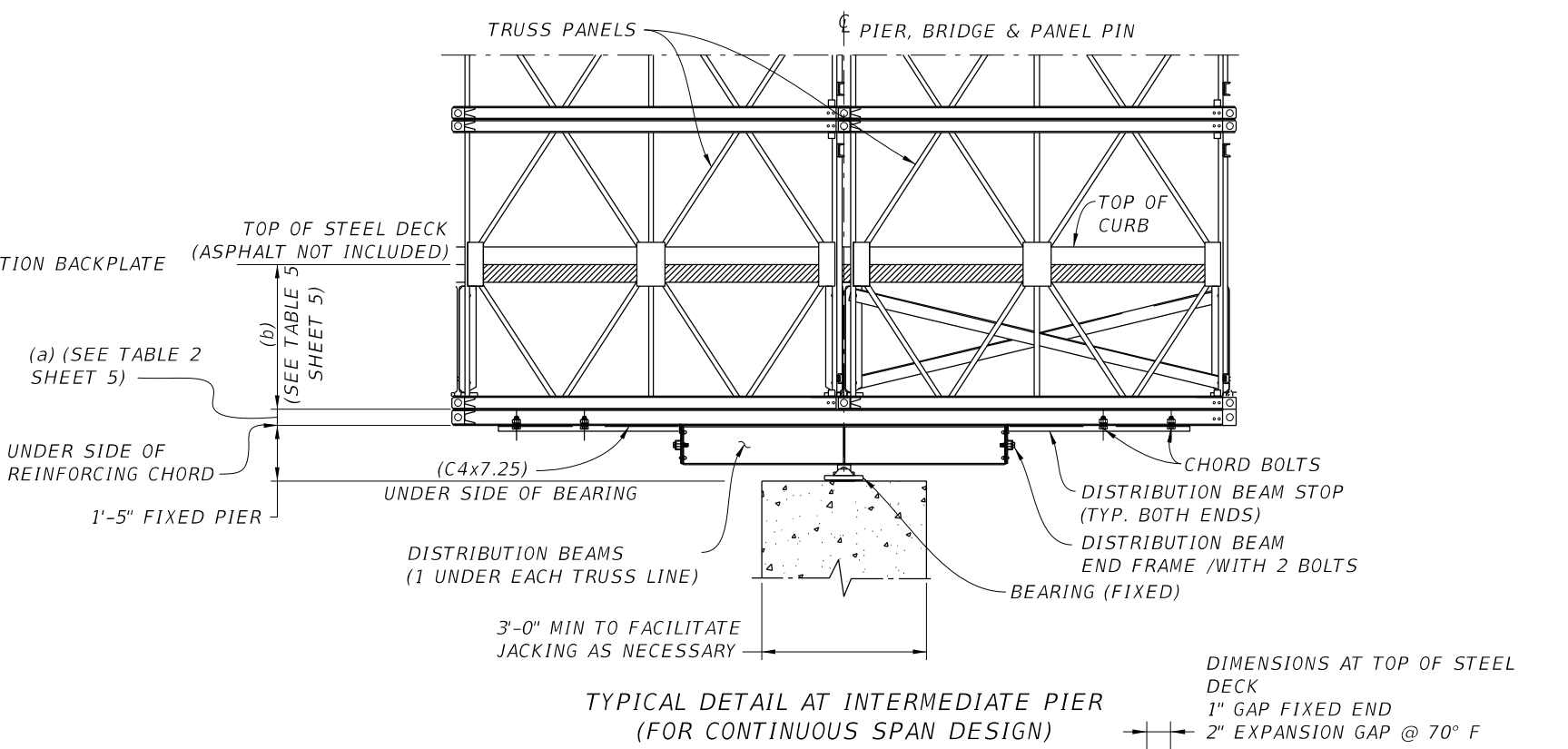

TYPICAL DETAIL AT INTERMEDIATE PIER (FOR CONTINUOUS SPAN DESIGN)

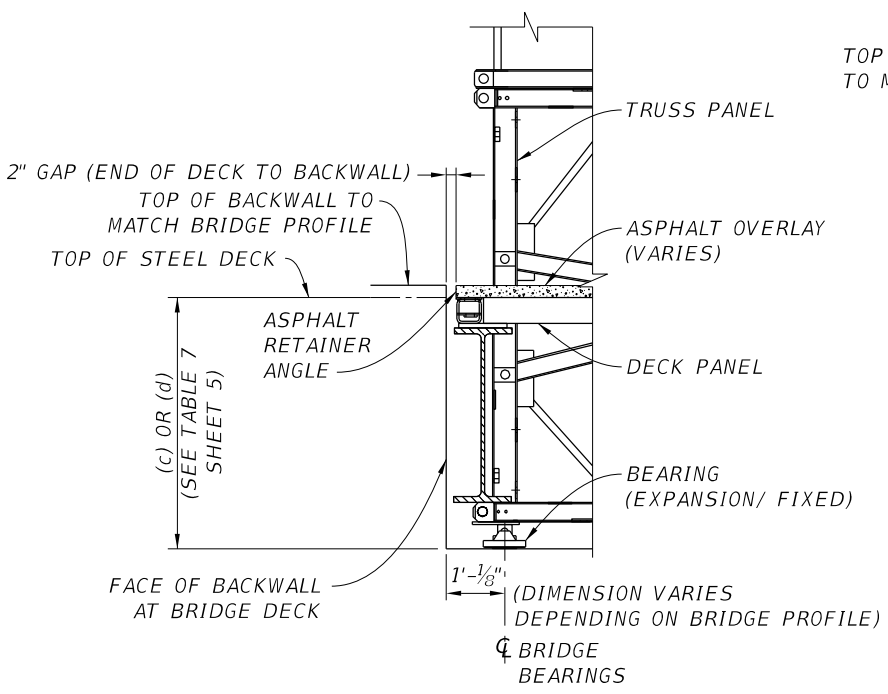

TYPICAL DETAIL AT ABUTMENTS (Note: Expansion joint depends on span/bridge length and configuration)

NOTE: SEE ACROW TECHNICAL HANDBOOK AND PARTS LIST FOR ITEM NUMBER DETAILS.

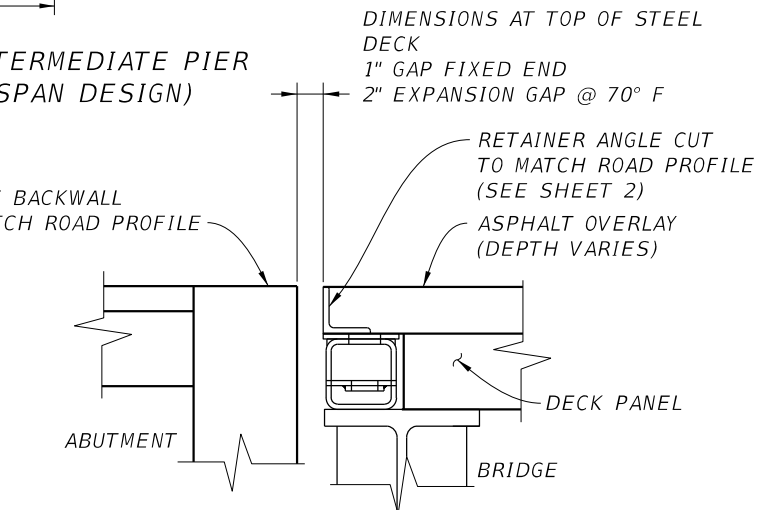

EOB AT DECK DETAIL (Note: Expansion joint depends on span/bridge length and configuration)

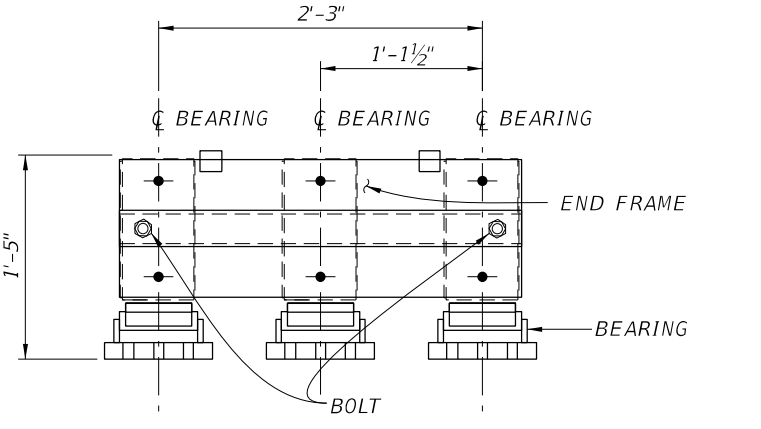

DISTRIBUTION BEAM DETAIL - END VIEW (Triple Truss Shown)

9/23/2021 8:00:56 AM

LAST REVISION 11/01/20	REVISION	DESCRIPTION:		FY 2022-23 STANDARD PLANS	TEMPORARY ACROW SERIES 700XS DETOUR BRIDGE TYPICAL DETAILS	INDEX 102-201	SHEET 3 of 5
---------------------------	----------	--------------	--	------------------------------	---	------------------	-----------------

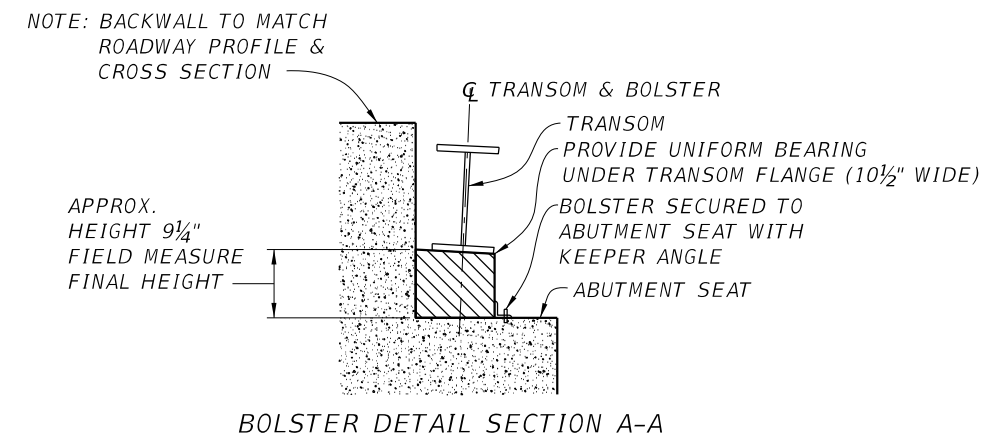
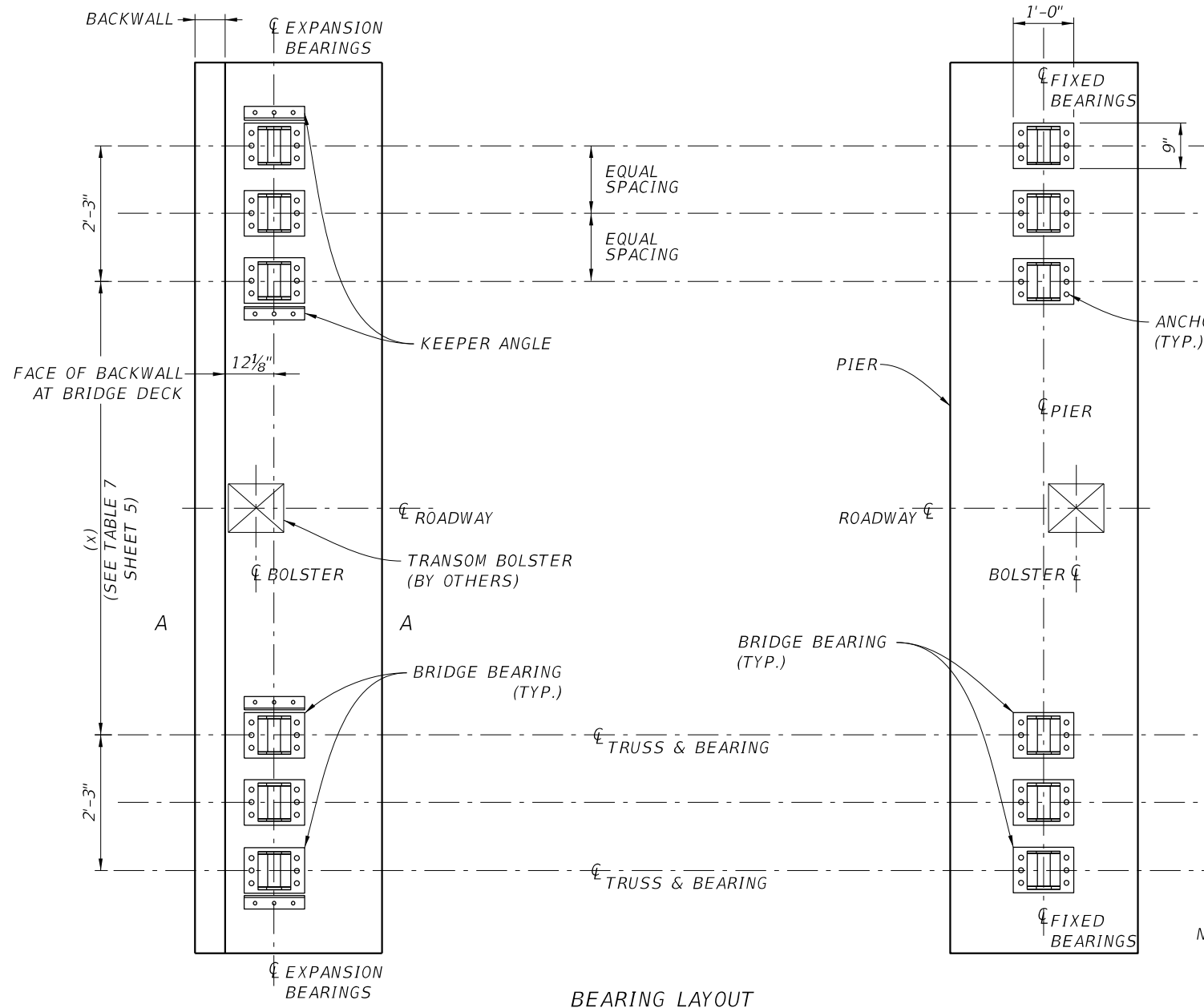

- NOTE:**
- HARDWOOD BLOCKING IS RECOMMENDED; SEE PLAN FOR FINAL BOLSTER DESIGN.
  - INSTALL BOLSTER TO A TIGHT FIT AFTER BRIDGE & DECK ARE IN PLACE.
  - BOLSTER HEIGHT WILL VARY BASED ON TRANSOM TYPE/ DEAD LOADS.
  - BOLSTER TO BE SECURED FROM MOVEMENT AFTER INSTALLATION.
  - BOLSTER TO MATCH SLOPE OR TRANSOM FLANGE.

**NOTE:** SEE PLANS FOR SIZE, GRADE AND QUANTITY OF ANCHOR BOLTS AND KEPPER ANGLES NOT INCLUDED WITH BRIDGE PARTS. TRIPLE TRUSS SHOWN. DOUBLE TRUSS WOULD NOT INCLUDE CENTER BEARING.

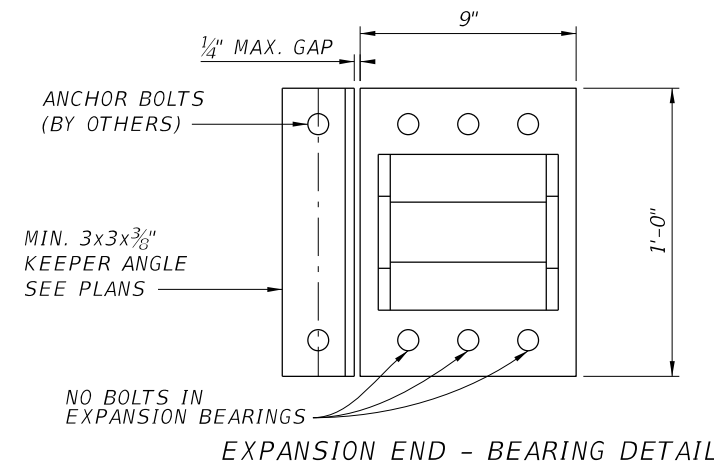
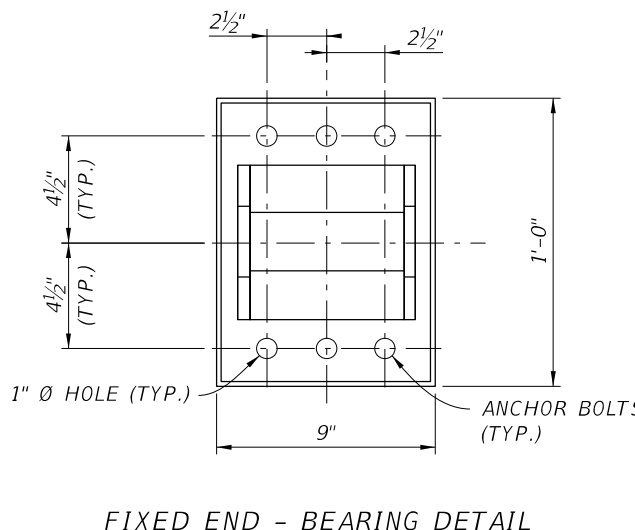
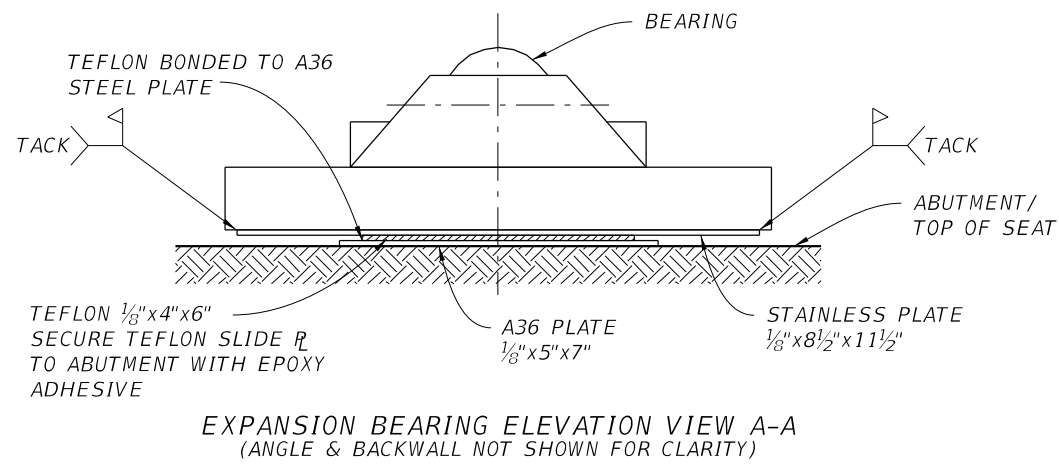

9/23/2021 8:00:57 AM

LAST REVISION 11/01/20	DESCRIPTION:		FY 2022-23 STANDARD PLANS	TEMPORARY ACROW SERIES 700XS DETOUR BRIDGE BEARING LAYOUT AND DETAILS	INDEX 102-201	SHEET 4 of 5
---------------------------	--------------	--	------------------------------	--	------------------	-----------------

TABLE 1				
Swaybrace / Transom Brace				
Bridge Roadway width (ft)	Transom	Swaybrace Part # (Single)	Swaybrace Part # (Double)	Transom Brace Part #
24	SC0017	AB590	AB515	AB519
36	AB957	AB891	AB891	AB519
42	AB978	AB979	AB979	AB519

TABLE 2		
(a) Reinforcing Chord Thickness		
Regular Reinforcing Chord Thickness	Heavy Reinforcing Chord Thickness	SuperHeavy Reinforcing Chord Thickness
4"	5"	6"

TABLE 3		
Bridge Roadway width (ft)	Transom Part #	(b) Height Bottom of Truss Chord to top of Transom
24	SC0017	28 <sup>5</sup> / <sub>16</sub> "
36	AB957	40 <sup>3</sup> / <sub>16</sub> "
42	AB978	43"

TABLE 4			
Bridge Roadway width (ft)	Transom Part #	(x) $\bar{C}$ to inner truss to $\bar{C}$ inner truss	(y) Transom Beam Length
24	SC0017	26'-1"	31'-4"
36	AB957	38'-4 <sup>13</sup> / <sub>16</sub> "	43'-7 <sup>13</sup> / <sub>16</sub> "
42	AB978	44'-4 <sup>3</sup> / <sub>8</sub> "	49'-7 <sup>3</sup> / <sub>8</sub> "

TABLE 5		
Bridge Roadway width (ft)	Transom Part #	(b) Height Bottom of Truss Chord to top of Deck
24	SC0017	33 <sup>11</sup> / <sub>16</sub> "
36	AB957	45 <sup>9</sup> / <sub>16</sub> "
42	AB978	48 <sup>3</sup> / <sub>8</sub> "

TABLE 6			
Bridge Roadway width (ft)	Transom Part #	(c) Height Bottom of fixed bearing to top of Deck	(d) Height Bottom of expansion bearing to top of Deck
24	SC0017	39 <sup>1</sup> / <sub>16</sub> "	39 <sup>7</sup> / <sub>16</sub> "
36	AB957	50 <sup>15</sup> / <sub>16</sub> "	51 <sup>5</sup> / <sub>16</sub> "
42	AB978	53 <sup>3</sup> / <sub>4</sub> "	54 <sup>1</sup> / <sub>8</sub> "

TABLE 7		
Bridge Roadway width (ft)	Transom Part #	(x) $\bar{C}$ to inner truss to $\bar{C}$ inner truss
24	SC0017	26'-1"
36	AB957	38'-4 <sup>13</sup> / <sub>16</sub> "
42	AB978	44'-4 <sup>3</sup> / <sub>8</sub> "

9/23/2021 8:00:58 AM