

NOTE:
If median width does not allow standard offset from both roadway, center sign in median.

CASE I

Use on Limited Access Roadways

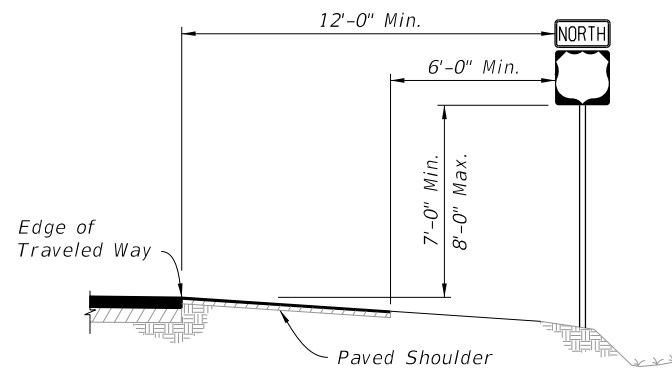

CASE II

Use on Arterial and Collector Roadways, and Limited Access Ramps

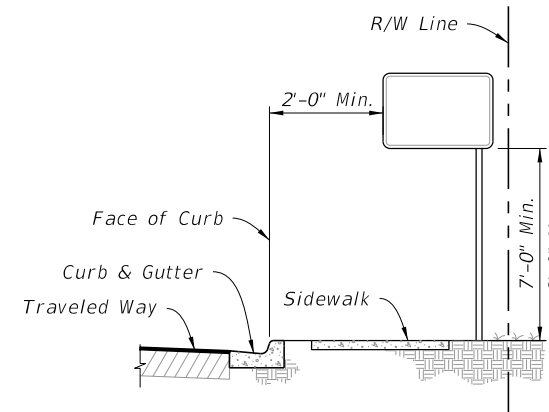

CASE III

Use on Arterial and Collector Roadways

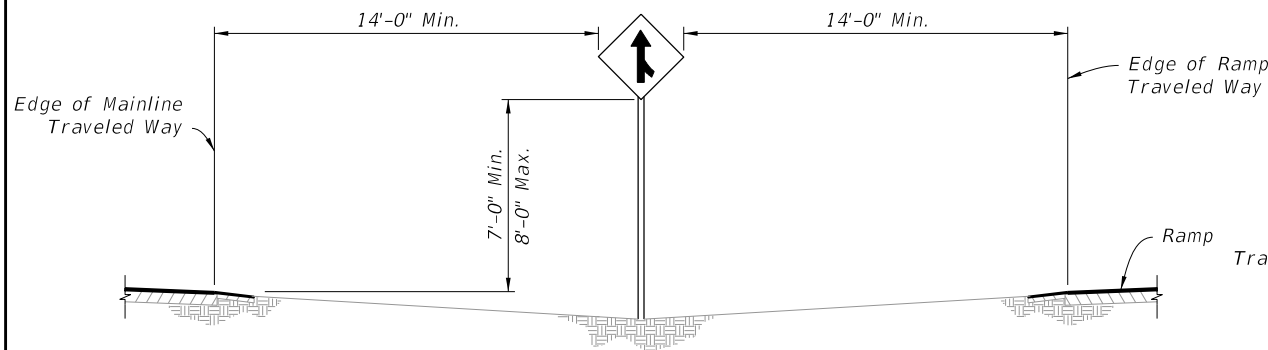

CASE IV

Use on Limited Access Roadways

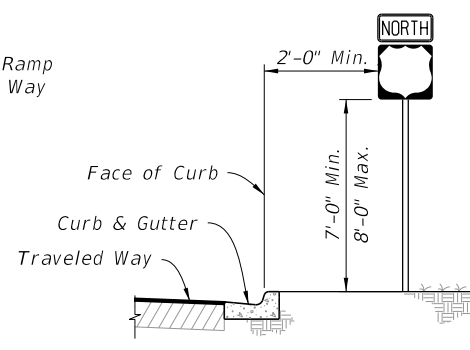

CASE V

Use in Business or Residential Areas Only

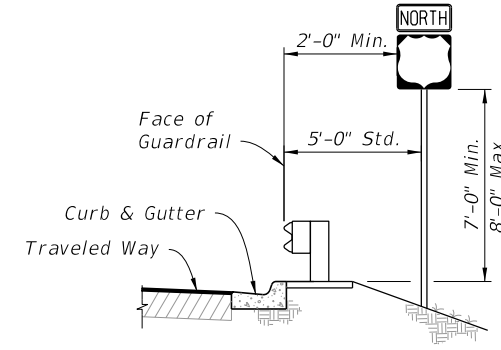

CASE VI

Use on Roadways With Signs Behind Guardrail

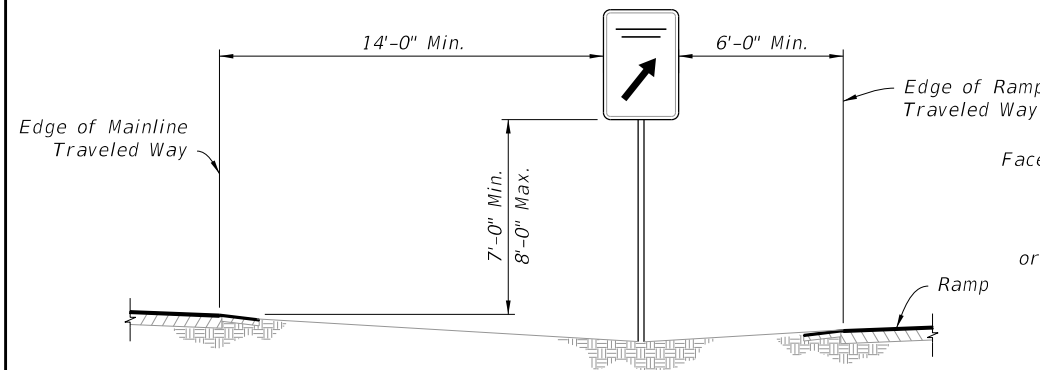

CASE VII

REST AREA AND EXIT GORE SIGNS
Use on Limited Access Roadways

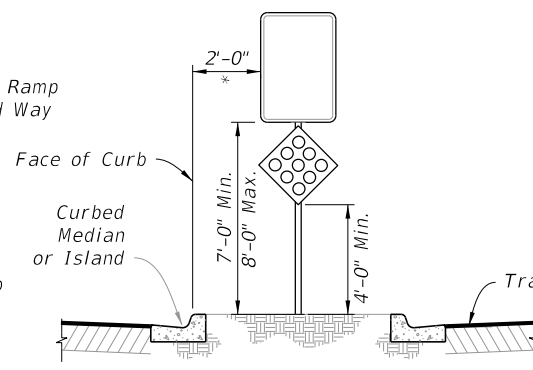

CASE VIII

Use on Island or Curbed Median

* For separators <6'-0", center the sign within the separator, center sign column on island

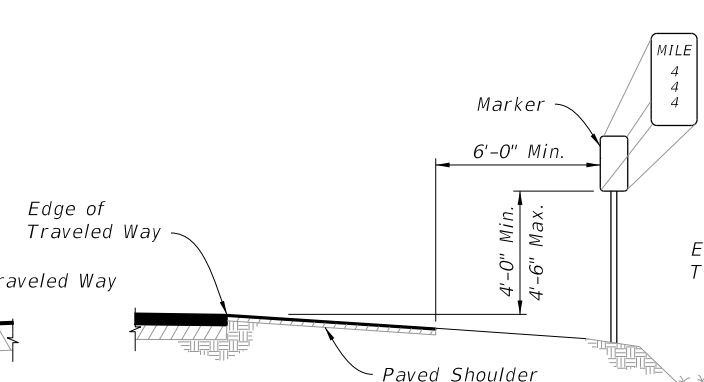

CASE IX

MILE POST MARKER
Use on Limited Access Roadways

NOTE:
For more information refer to Section 2H of the MUTCD.

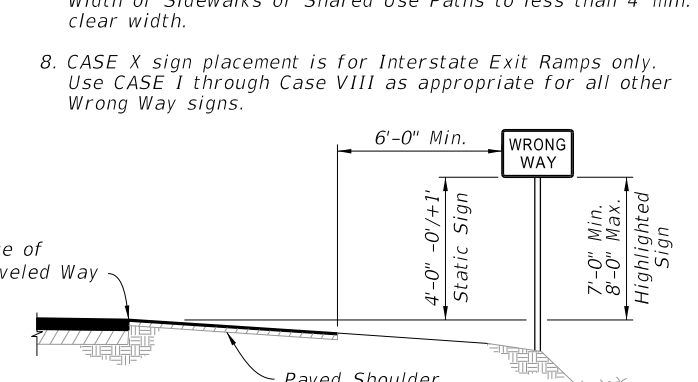

CASE X

WRONG WAY SIGNS
(See Note 8)

GENERAL NOTES:

1. Single-Column Signs Shown, Multi-Column Signs similar. These typical sections serve as a guide for locating the traffic signs required under various roadside conditions. For size and details of sign construction and footing, refer to the appropriate Index and Plans.
2. Verify the length of sign supports in the field prior to fabrication.
3. Install ground signs at an angle of 1 to 4 degrees away from the traffic flow (see illustration). Install shoulder mounted signs rotated counterclockwise and median mounted signs rotated clockwise. Install signs on a curve as noted above from the perpendicular to the motorist line of sight.

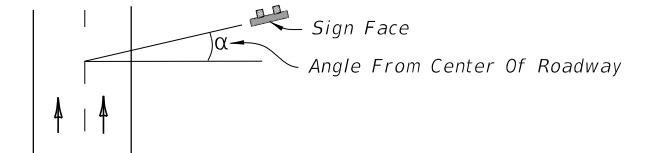

4. The setback for Stop and Yield signs may be reduced to 3' minimum from the Edge of Traveled Way if required for visibility in business or residential sections with no curb and speeds of 30 MPH or less.

5. The mounting heights are measured from the bottom of the sign panel to a horizontal line extended from the Edge of Traveled Way or from the ground surface at the back of curb. If the standard heights cannot be met, the minimum heights are as follows:

Limited Access Roadways - 7'

Arterial and Collector Roadways:

- 5' - Rural
- 7' - Urban (including residential with parking and/or pedestrian activity)

Limited Access Roadways:

If a secondary sign is mounted below the major sign, mount the major sign so that the bottom of the sign is at least 8' above the edge of the traveled way and the secondary sign at least 5' above the edge of the traveled way.

Arterial and Collector Roadways:

- Rural, mount the secondary sign at least 5' above the edge of the traveled way.
- Urban, mount the secondary sign at least 7' above the edge of the traveled way.

6. Do not install sign supports in the bottom of ditches.
7. Install sign supports so they do not reduce the accessible width of Sidewalks or Shared Use Paths to less than 4' min. clear width.
8. CASE X sign placement is for Interstate Exit Ramps only. Use CASE I through Case VIII as appropriate for all other Wrong Way signs.

11/20/2020 10:05:29 AM

LAST REVISION 11/01/19	DESCRIPTION:	 FY 2021-22 STANDARD PLANS	TYPICAL SECTIONS FOR PLACEMENT OF SINGLE AND MULTI-COLUMN SIGNS	INDEX 700-101	SHEET 1 of 1
---------------------------	--------------	---	--	------------------	-----------------