

**NOTES:**

1. Work with Index 700-010.
2. Shop Drawings: Not required.
3. Materials:
  - A. Steel Plate: ASTM A36 or ASTM A709 Grade 36
  - B. Steel Pipe (Support Post): ASTM A53 Grade B Schedule 40
  - C. Galvanized U-Bolts, Nuts and Plate Washer
    - a. U-Bolts: ASTM A449
    - b. Hex Nuts: ASTM A 563 Lock Nuts
    - c. Plate Washer: ASTM A 36 or ASTM A709 Grade 36 or 50
  - D. Galvanized Anchor Bolts, Nuts and Washers:
    - a. Anchor Rod: ASTM F1554 Grade 55 fully threaded (for Adhesive Anchors)
    - b. Anchor Bolts: ASTM F1554 Grade 55 Grade A Hex
    - c. Nuts: ASTM A563 Heavy Hex Locking
    - d. Washers: ASTM F436
  - E. Adhesive Anchor Bonding Material: Specification 937 Type HV Adhesive
  - F. Weld Material: E70XX
  - G. Snap-In Post Cap: UV and weather-resistant glass-filled polyester cap
4. Coating:
  - A. U-Bolts, Threaded Rods, Nuts and Washers: ASTM F2329
  - B. Other Steel: ASTM A123
5. Fabrication:
  - A. Weld: Specification 460-6.4
  - B. Hot dip galvanize after fabrication
6. Construction:
  - A. Locate Sign Support a minimum of 5 feet from an open joint or transition (sign stationing may be adjusted to accommodate this requirement)
  - B. Base plate must be flush with top of Railing
  - C. Anchors in Traffic Railings:
    - a. Install Adhesive Anchors in accordance with Specification 416 except perform field test on one anchor per sign support location
    - b. Use template and tie anchors as necessary to maintain correct placement of C-I-P Embedded Anchors
    - c. Do not drill into existing reinforcing
  - D. Temporary Signs on Permanent Traffic Railings, Same as Permanent except field testing of anchors is not required
  - E. Temporary Signs on Temporary Railings/Barriers:
    - a. Install Sign Supports at the midpoint along the length of a single segment
    - b. Avoid drilling through existing reinforcement; use of metal detector not required.
    - c. Field testing of anchors is not required
7. Removal of Temporary Signs on Permanent Traffic Railings:
  - A. Cut anchor rods flush with the top of the railing
  - B. Coat anchors with Type F-1 epoxy to prevent corrosion
    - a. Extend coating 2 inches beyond edge of cut anchor rods
    - b. Epoxy coating 1/16" thick minimum
8. Payment:

Include the cost of all materials and labor in the cost of the single post sign assembly.

TABLE 1 - SIGN PANEL AND POST SIZING		
	Max. Sign Area (SF)	Post (NPS)
Temporary Signs	≤ 24	3.0
Permanent Signs	< 13.5	3.0
	13.5 < Sign < 20	3.5

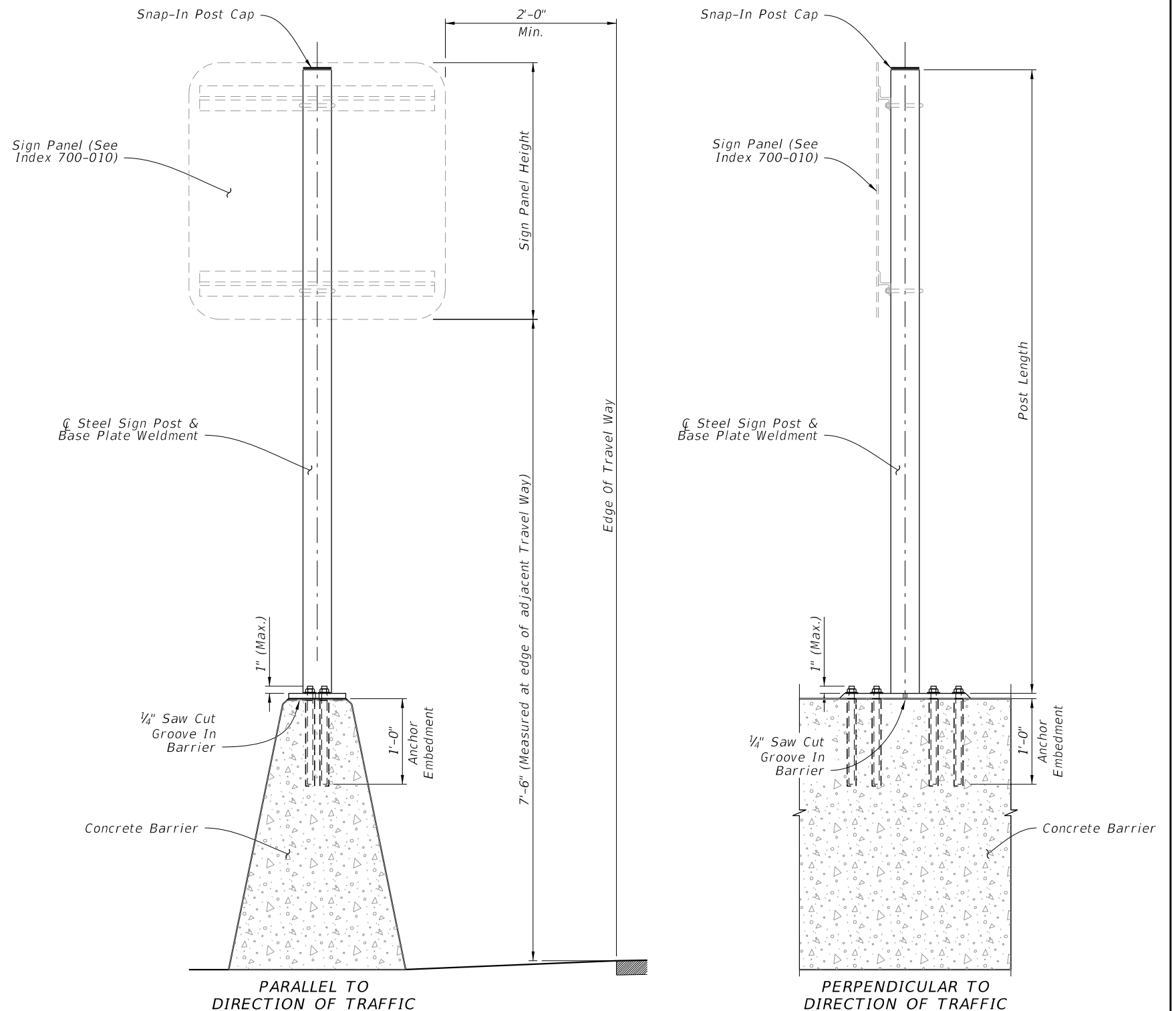

(Index 521-001 Median Barrier shown; others similar)

ELEVATION

10/12/2020 8:55:53 AM

LAST REVISION 11/01/18	REVISION	DESCRIPTION:	 FY 2021-22 STANDARD PLANS	SINGLE POST MEDIAN BARRIER MOUNTED SIGN SUPPORT	INDEX 700-013	SHEET 1 of 2
---------------------------	----------	--------------	---	--	------------------	-----------------

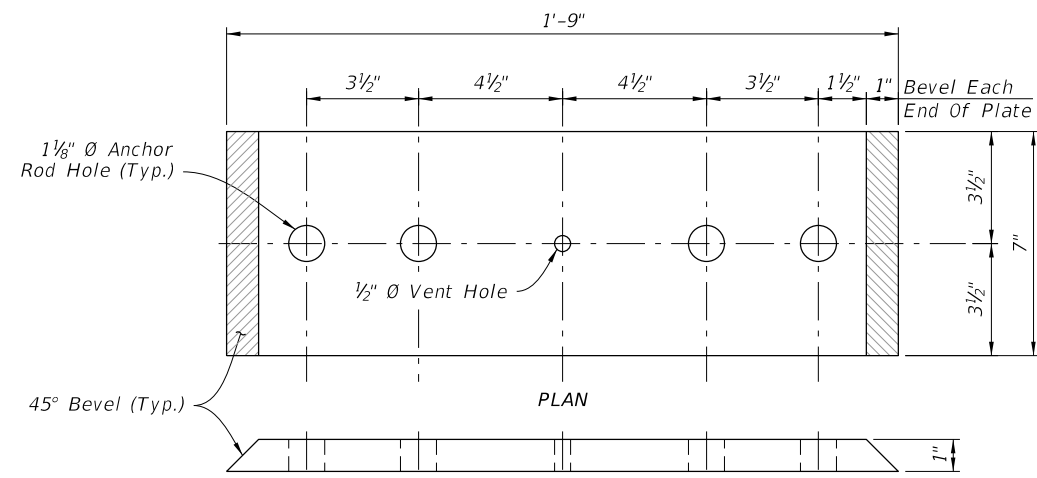

**BASE PLATE TYPE A**  
(Linear Anchor Rod Pattern)

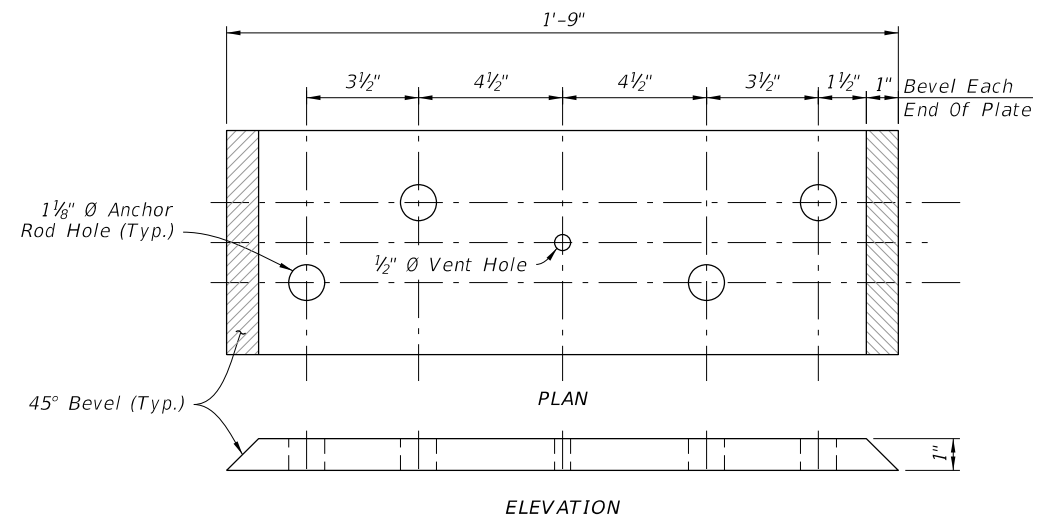

**BASE PLATE TYPE B**  
(Staggered Anchor Rod Pattern)

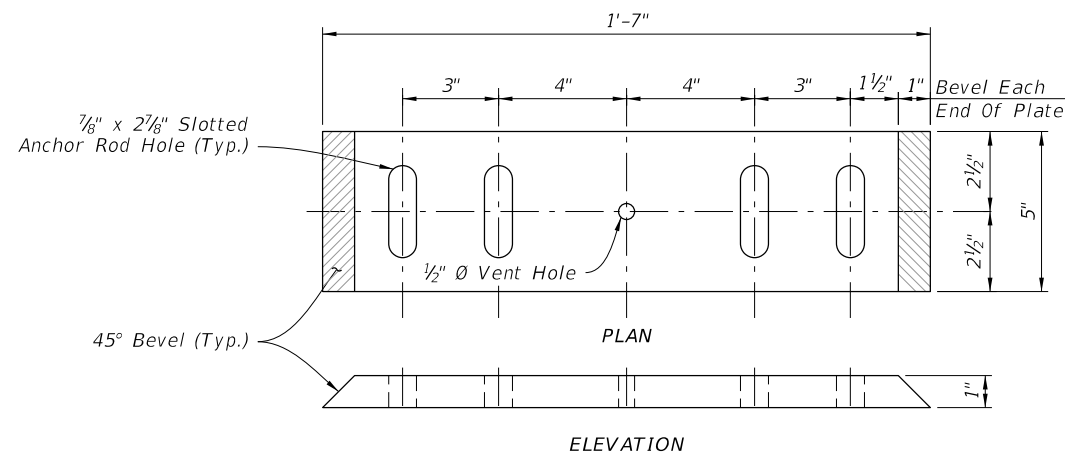

**BASE PLATE TYPE C**

**NOTES:**

1. Place anchor rods in a staggered or linear pattern as necessary to avoid reinforcing.
2. Use a staggered pattern for all temporary barriers.

Index	Type/Application	Base Plate Type	Anchor Rod $\emptyset$
521-001	Full Wall	B	1"
521-001	Cantilever or L-Wall	A	
All listed above Plus 102-110 & 102-100	Temporary Signs	C	3/4"

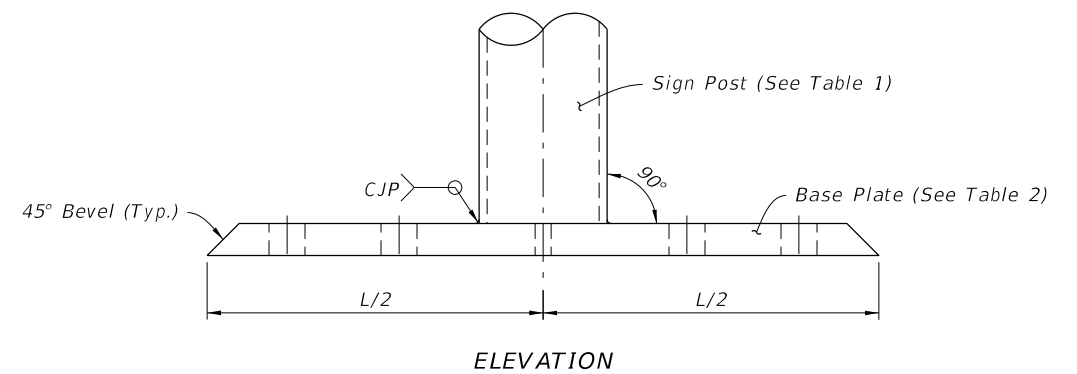
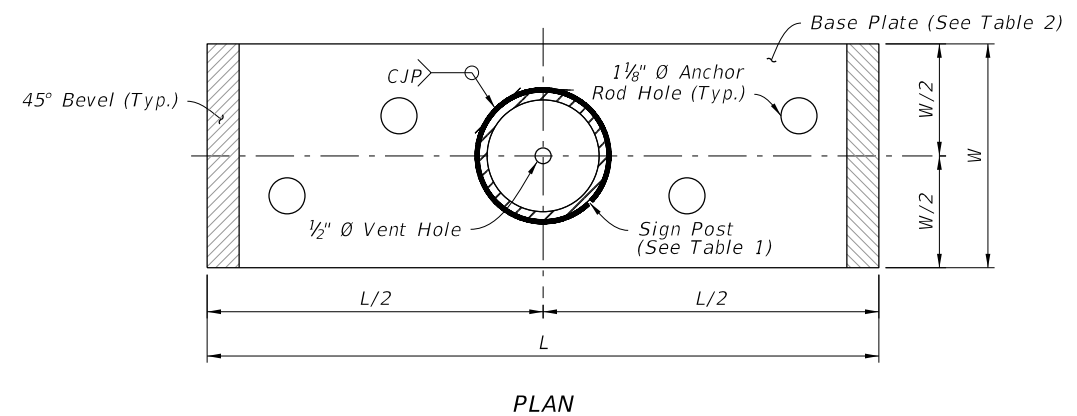

**SIGN SUPPORT WELDMENT DETAIL**  
(Staggered Anchor Rod Pattern shown)

10/12/2020 8:55:56 AM

LAST REVISION 11/01/17	DESCRIPTION:
---------------------------	--------------