

* Construct $\frac{3}{4}$ " Open Joints plumb at Construction Joints in Junction Slabs or Footings.

PLAN
(Reinforcing Steel not shown for clarity)

CROSS REFERENCE:
 For Section A-A see Sheet 3.
 For Section C-C and Detail "A" see Sheet 5.
 For Wall mounted Barrier/Noise Wall Details see Index 521-512.
 For Footing mounted Barrier/Noise Wall Details see Index 521-513 (T-Shaped), 521-514 (L-Shaped) or 521-515 (Trench).

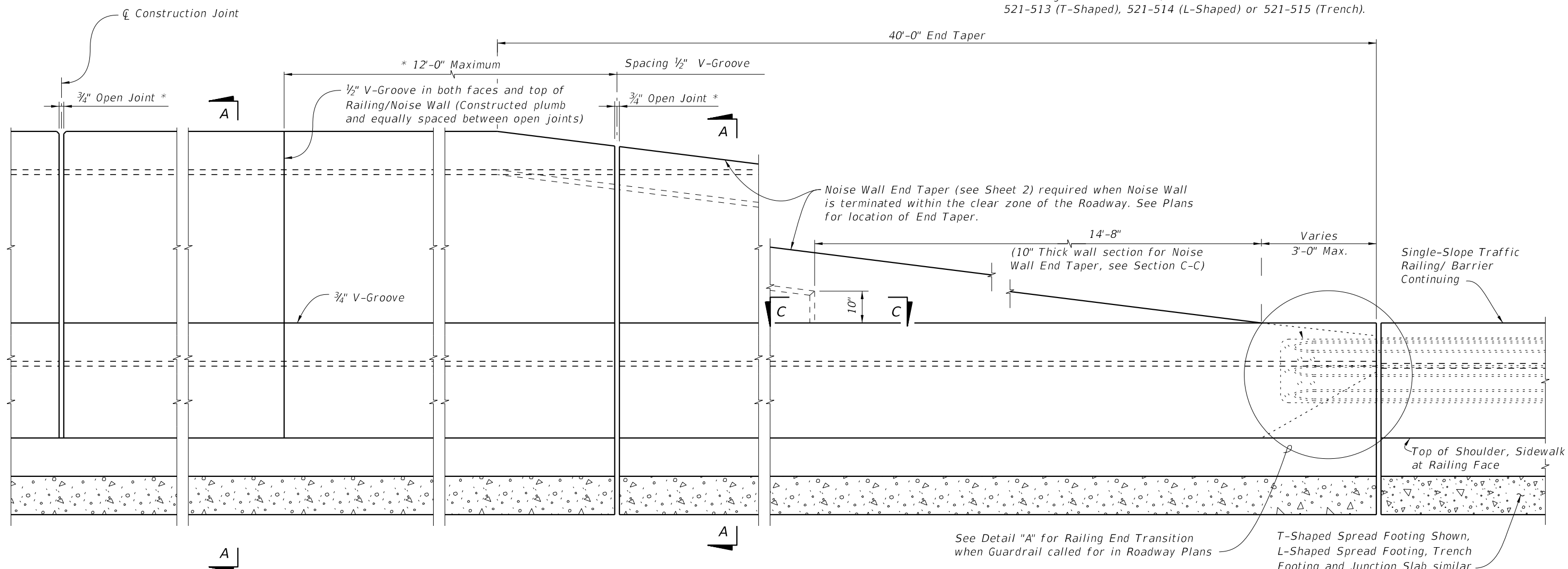

ELEVATION

(INSIDE FACE OF CONCRETE BARRIER/NOISE WALL WITH T-SHAPED FOOTING SHOWN,
 (Other footings similar, Reinforcing steel not shown for clarity)

- NOTES:**
1. Work this Index with Indexes 521-512 through 521-515.
 2. The Concrete Barrier/Noise Wall and joints shall be constructed plumb.
 3. Concrete:
 - A. Class II for slightly aggressive environments.
 - B. Class IV for moderately or extremely aggressive environments.
 4. Provide $\frac{3}{4}$ " Open Joints spaced between 30 feet minimum to 90 feet maximum. Align Open Joints with construction joints in the Junction Slab or Footing. Provide additional reinforcing (see Sheet 2) at each open joint.
 5. Install Barrier Delineators 2'-4" above the riding surface in accordance with Specification Section 705. Match the Barrier Delineators color (White or Yellow) to the near edgeline.
 6. Slip forming of the barrier portion is permitted.
 - A. Stem walls may be widened, at no additional cost, to accommodate slip forming.

10/12/2020 7:52:09 AM

LAST REVISION 11/01/19	REVISION	DESCRIPTION:	 FY 2021-22 STANDARD PLANS	CONCRETE BARRIER/NOISE WALL (8'-0")	INDEX 521-510	SHEET 1 of 5
---------------------------	----------	--------------	--	--	-------------------------	------------------------

10/12/2020 7:52:12 AM

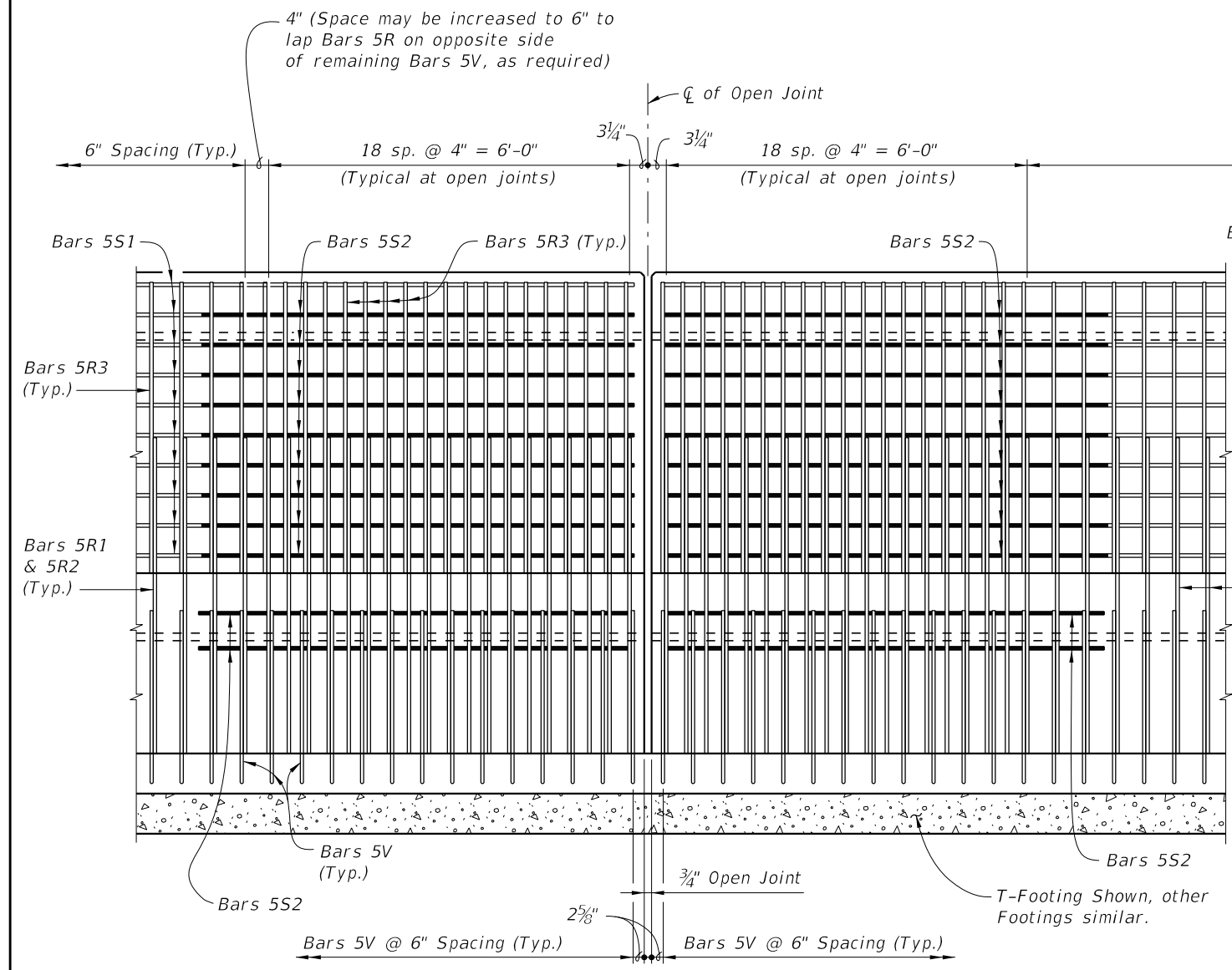

ELEVATION OF BARRIER/NOISE WALL REINFORCING STEEL AT OPEN JOINT
 (Bars 5S1 in Barrier not shown for clarity)
 (Footing or Junction Slab Details not shown)

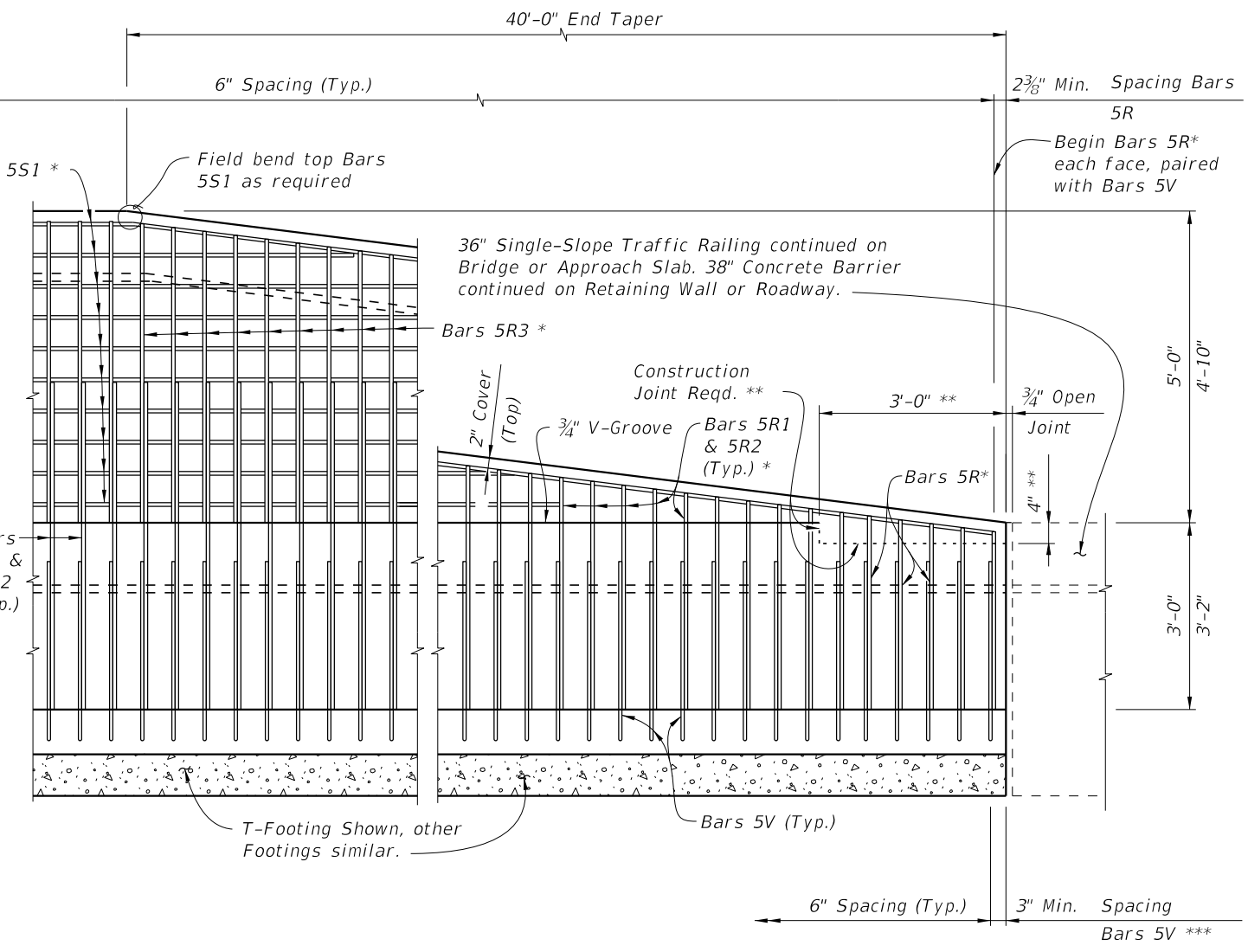

ELEVATION OF BARRIER/NOISE WALL END TAPER (ADJACENT TO CONCRETE BARRIER SHOWN, GUARDRAIL ATTACHMENT SIMILAR SEE DETAIL "A", SHEET 5)
 (Bars 5S1 in Railing not shown for clarity)
 (Footing or Junction Slab Details not shown)

- NOTES:
- * Field Cut Bars 5R & 5S1 to maintain clearance.
 - ** Terminate 3/4" V-groove at construction joint & cast top of railing with End Taper.
 - *** Bar spacing shown for Bars 5V only applies when Single-Slope Concrete Barrier continues. For transition to guardrail see Sheet 5. Work Traffic/ Railing Noise Wall reinforcing with Index 521-512 (Junction Slab) or Index 521-513 through 521-515 (T, L or Trench Footings)

LAST REVISION 11/01/18	REVISION	DESCRIPTION:	 FY 2021-22 STANDARD PLANS	CONCRETE BARRIER/NOISE WALL (8'-0")	INDEX 521-510	SHEET 2 of 5
---------------------------	----------	--------------	--	-------------------------------------	------------------	-----------------

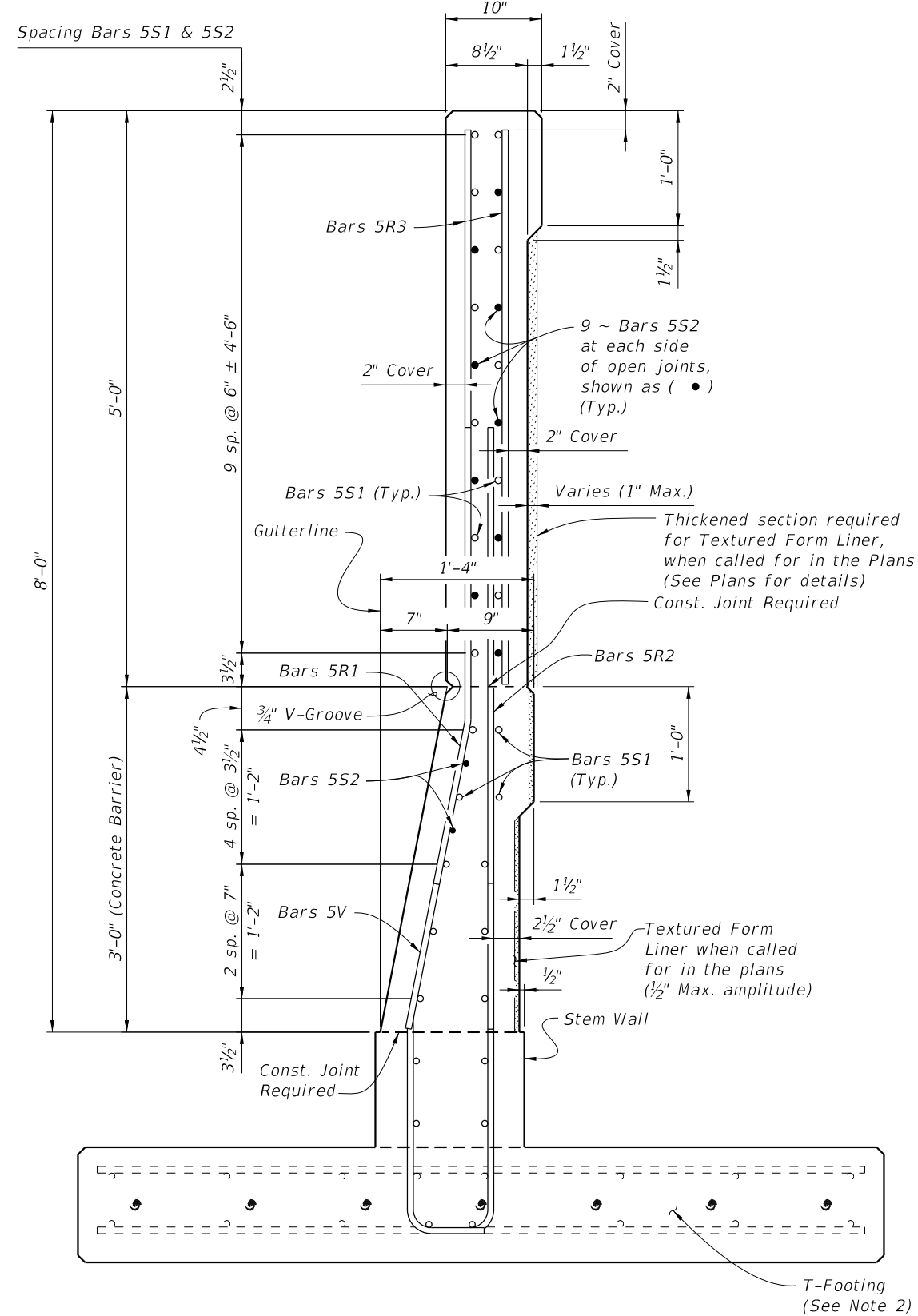

SECTION A-A
TYPICAL SECTION THRU CONCRETE BARRIER/NOISE WALL AT OPEN JOINT
 (Section Thru T-Footing Shown, Section Thru
 Junction Slab, L or Trench Footings similar)

NOTES:

1. Bars 5V shown are for T-Shape footings.
 5V for Junction Slab, L-Shape and Trench footings are similar.
2. Foundation Details:
 Index 521-512 (Junction Slab)
 Index 521-513 (T-Shape)
 Index 521-514 (L-Shape)
 Index 521-515 (Trench)

CROSS REFERENCE:

- For locations of Section A-A see Sheet 1.
- For location of View B-B, see Sheet 5.
- For Detail "A", see Sheet 5

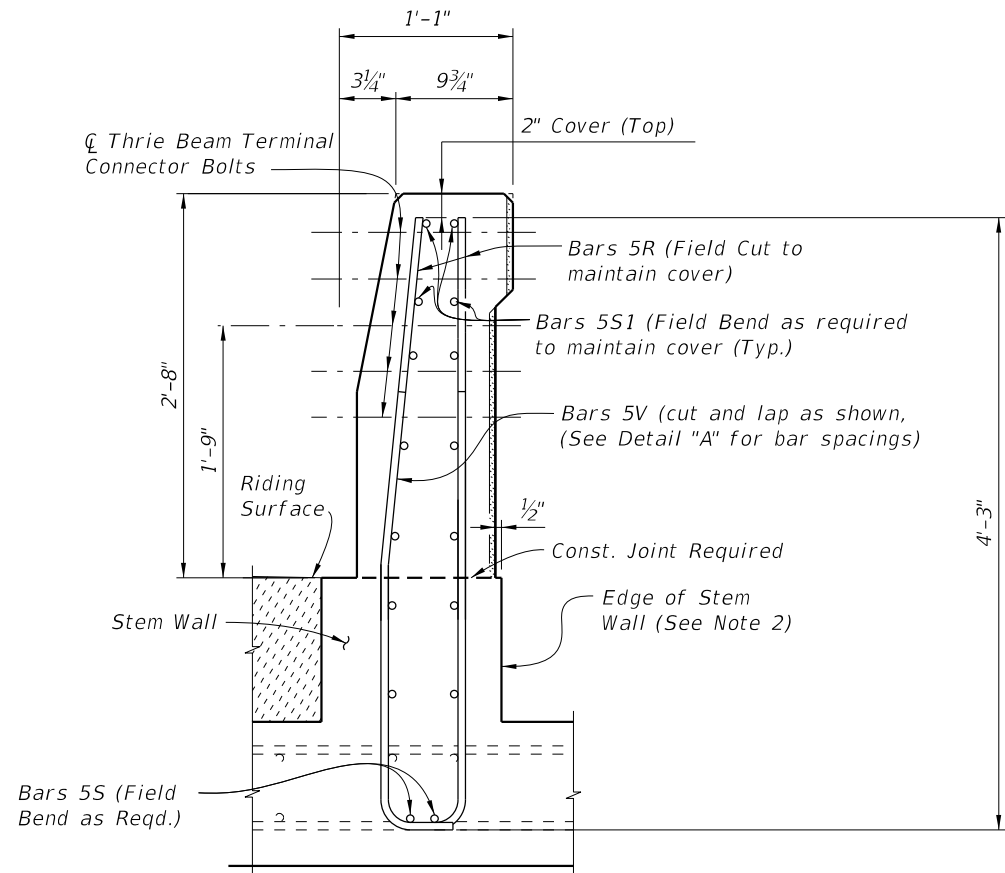

VIEW B-B
END VIEW OF RAILING END TRANSITION FOR
GUARDRAIL ATTACHMENT
 (T-Footing shown, Junction Slab, L or Trench Footings similar)

8/11/2021 9:32:23 AM

LAST REVISION 11/01/18	REVISION	DESCRIPTION:	 FY 2021-22 STANDARD PLANS	CONCRETE BARRIER/NOISE WALL (8'-0")	INDEX 521-510	SHEET 3 of 5
---------------------------	----------	--------------	---	--	-------------------------	------------------------

REINFORCING STEEL BENDING DIAGRAMS

BILL OF REINFORCING STEEL		
MARK	SIZE	LENGTH
R1	5	5'-2"
R2	5	5'-2½"
R3	5	4'-10"
S1	5	As Reqd.
S2	5	7'-3"
V (Wall)	5	6'-6½"
V (T-Footing)	5	7'-8½"

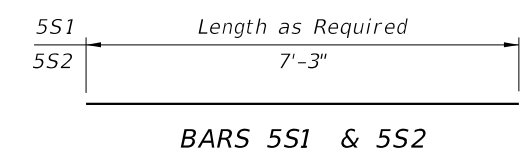

BARS 5S1 & 5S2

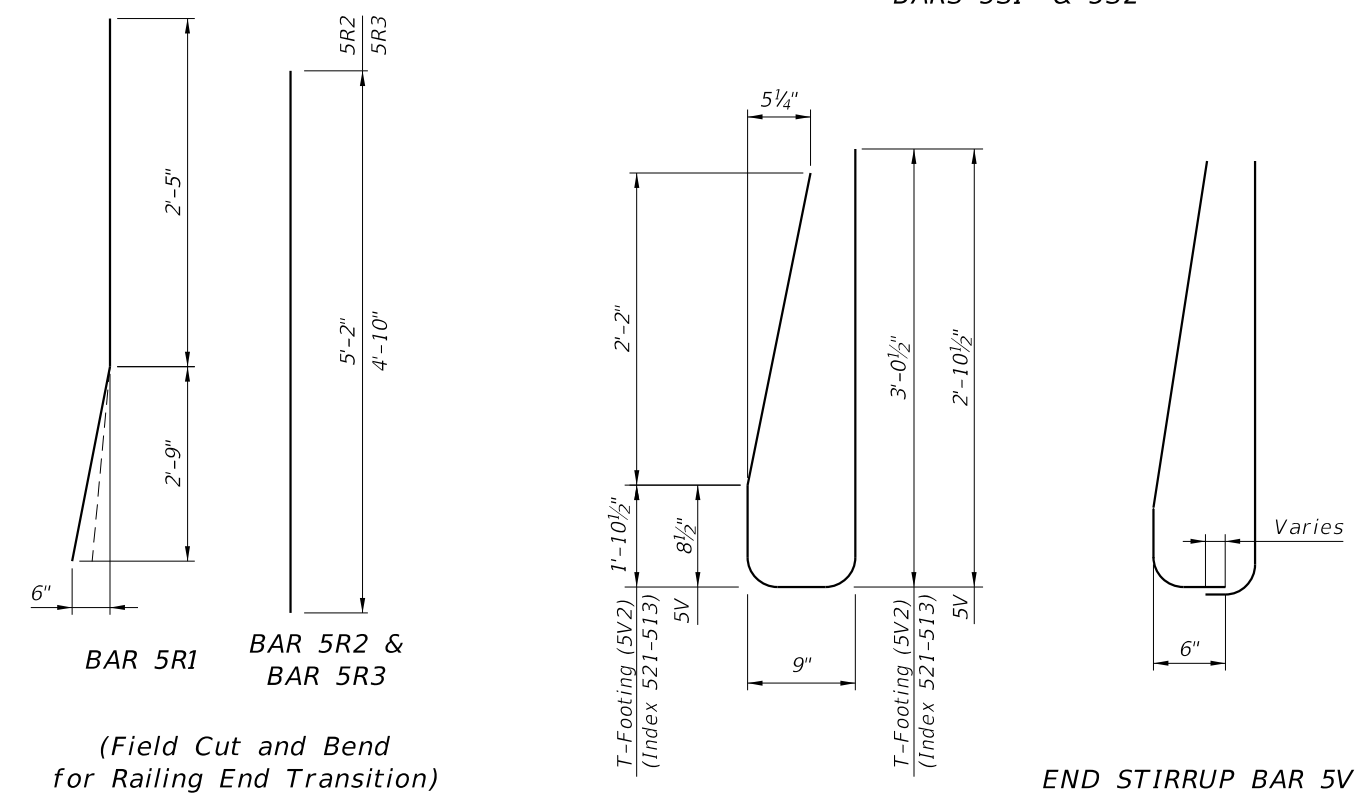

(Field Cut and Bend for Railing End Transition)

STIRRUP BAR 5V

END STIRRUP BAR 5V To Be Field Cut (Railing End Transition)

REINFORCING STEEL NOTES:

1. All bar dimensions in the bending diagrams are out to out.
2. All reinforcing steel at the open joints shall have a 2" minimum cover.
3. Bars 5R shall be one continuous or lap spliced bar. No mechanical couplers are permitted.
4. Bars 5S1 may be continuous or spliced at the construction joints. Lap splices for Bars 5R, 5S1 and 5W shall be a minimum of 2'-2".
5. The Contractor may use Welded Wire Reinforcement (WWR) when approved by the Engineer. WWR must consist of deformed wire meeting the requirements of Specification Section 931.
6. See Index 521-514 and 521-515 for L-shaped and Trench footing vertical reinforcing.

ESTIMATED TRAFFIC RAILING/NOISE WALL QUANTITIES		
ITEM	UNIT	QUANTITY
Concrete (Railing)	CY/LF	0.107
Concrete (Noise Wall)	CY/LF	0.136
Reinforcing Steel (Typical)	LB/LF	69.36
Additional Reinf. @ Open Joint	LB	226.85

(The above quantities are based on the Concrete Barrier/ Noise wall typical section, (excluding junction slab or footing)

CROSS REFERENCE:
See Index 521-512 for Junction Slab Details and Indexes 521-513 thru 521-515 for additional footing details.

10/12/2020 7:52:16 AM

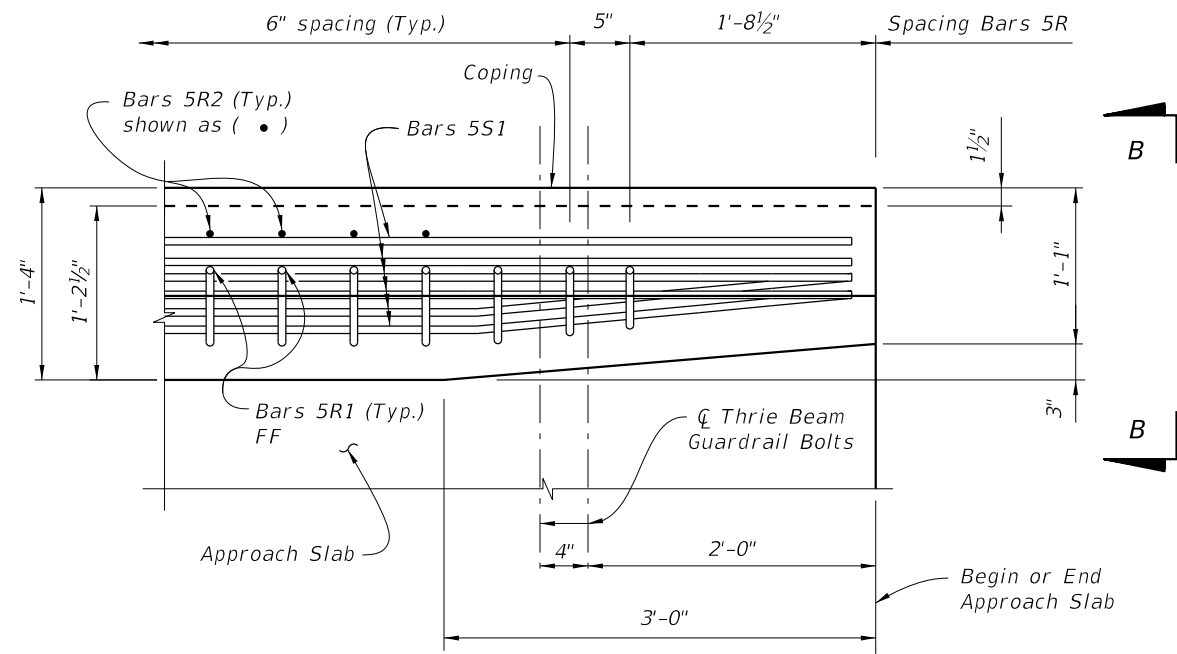

PLAN - RAILING END TRANSITION
(Showing Bars 5R, and Bars 5S1)
(Bars 5V not shown for Clarity)

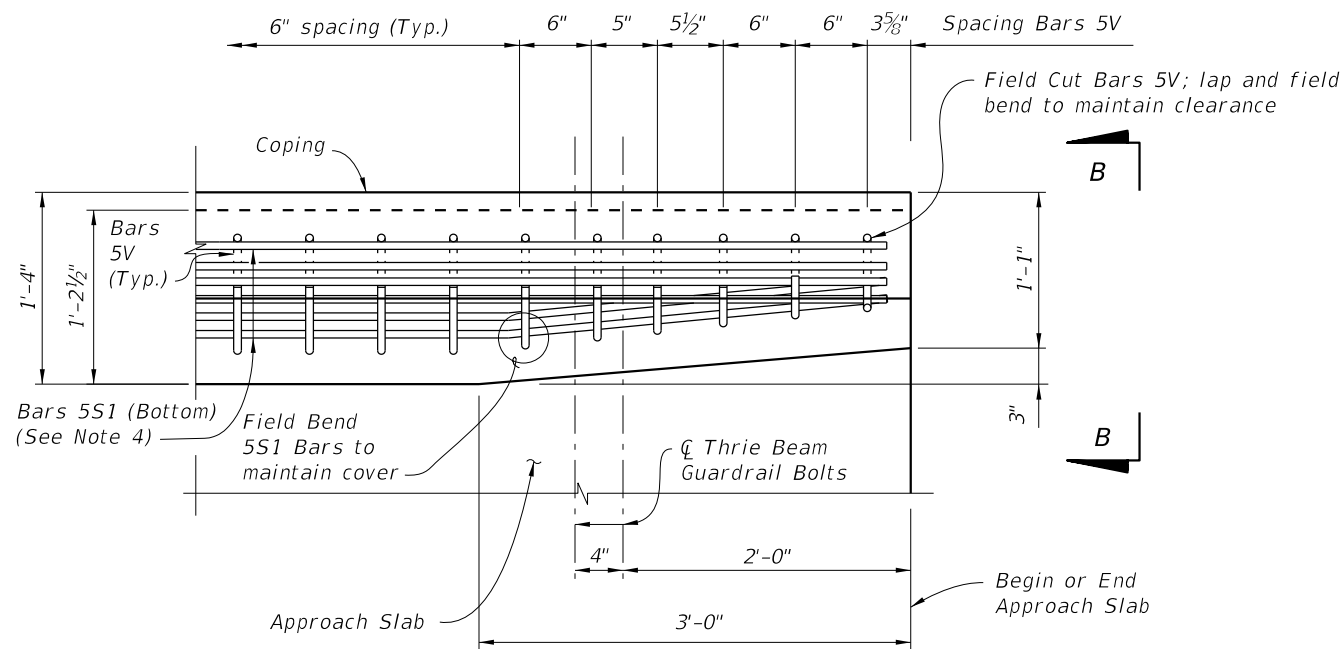

PLAN - RAILING END TRANSITION
(Showing Bars 5V and Bars 5S1)
(Bars 5R not shown for Clarity)

DETAIL "A"

DETAIL "A" NOTES:

1. Begin placing Railing Bars 5V at the railing end and proceed toward the guardrail (thrie beam) terminal connector to ensure placement of guardrail bolt holes. Pair Bars 5R with Bars 5V as shown. Clearance of Bars 5R & 5V to guardrail bolt holes shall be checked to prevent cutting of bars if bolt holes are to be drilled. Shift bars locally where conflicts occur.
2. For Guardrail connection details see Index 536-001.
3. Omit Railing End Transition if a Single-Slope Concrete Barrier/ Barrier continues beyond the End Taper. See the Plan Sheets.
4. Field cut Bars 5R2 to maintain cover. Field cut Bars 5V and lap as necessary to maintain cover; field cut & bend Bars 5R1 front leg (more plumb) to maintain cover and tie to S1 Bars. (See Sheet 1 Notes 1 and 2)

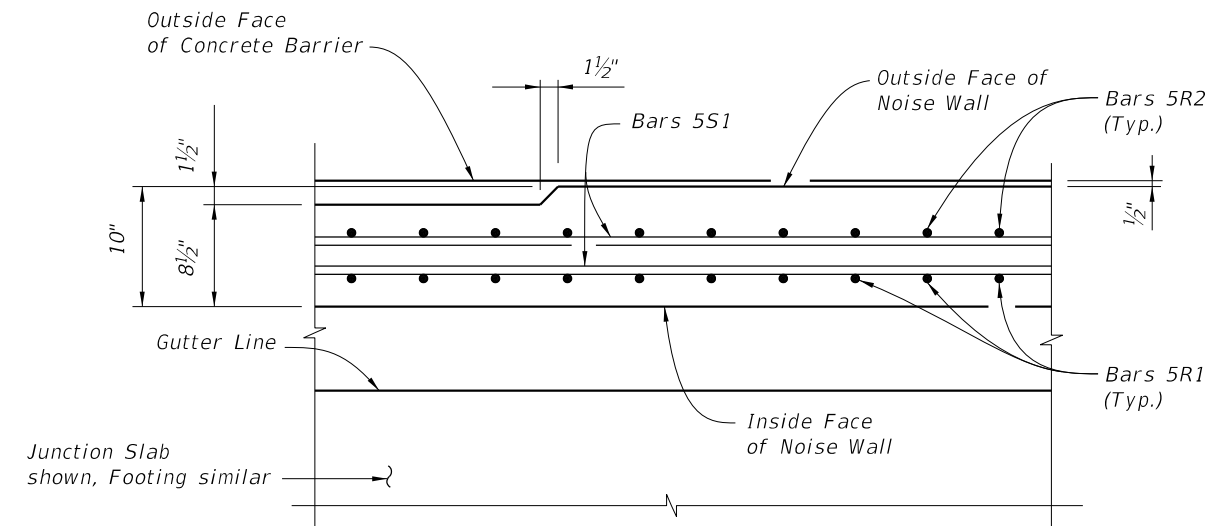

SECTION C-C
THRU NOISE WALL END TAPER

CROSS REFERENCE:

- For location of Detail "A" see Sheet 1.
For location of Section C-C see Sheet 1.
For View B-B see Sheet 3.

10/12/2020 7:52:18 AM

LAST REVISION 11/01/18	DESCRIPTION:
---------------------------	--------------



FY 2021-22
STANDARD PLANS

CONCRETE BARRIER/NOISE WALL (8'-0")

INDEX
521-510

SHEET
5 of 5