

**ELEVATION OF INSIDE FACE OF RAILING**  
 (Reinforcing Steel not shown for clarity)  
 (Railing on Bridge Deck and Approach Slab shown, Railing on Retaining Wall similar)

CROSS REFERENCE:  
 For Section A-A, View B-B,  
 Detail "A" and Detail "B",  
 see Sheet 2. For Detail "C",  
 see Sheet 4.

**TRAFFIC RAILING NOTES**

1. Materials: See Structures Plans, General Notes
2. Guardrail Connection Details: See Index 536-001
3. Superelevation: Traffic Railings on Superelevated bridges may be constructed perpendicular to the roadway surface. If an adjoining railing is constructed plumb, transition the end of the Traffic Railing from perpendicular to plumb over a minimum distance of 20'-0". The cost of all modifications will be at the Contractor's expense.
4. Name, Date & Bridge Number: Place the Name and Bridge Number on the Traffic Railing on the driver's right side when approaching the bridge. Place the Date on the driver's left side when approaching the bridge. Use the Name as shown in the General Notes of the Structures Plans. The Date is the year the bridge is completed. For a widening when the existing railing is removed, use both the date on the removed rail and the year of the widening. Form letters and figures with 3/8" V-Grooves using preformed letters and figures. Black plastic letters and figures 3" tall may be used, if approved by the Engineer.
5. Open Joints: See the Superstructure Plans, Approach Slab and Retaining Wall Sheets for Deck Joint dimensions and orientation. Provide Open Railing Joints matching the dimensions of the Deck Joint at Deck Expansion Joint locations.
  - A. For treatment of railings on skewed bridges see Sheet 3.
6. Open Joints: Provide 3/4" Open Joints at:
  - A. Superstructure supports where the slab is continuous.
  - B. At ends of approach slabs when adjacent to retaining walls and at expansion joints on retaining wall junction slabs.
7. V-Grooves: Construct 1/2" V-Grooves plumb. Space V-Grooves equally between 3/4" Open Joints and/or Deck Joints and the at V-Groove locations on the Retaining Wall footing/junction slabs.
8. Barrier Delineators: Install Barrier Delineators on top of the Traffic Railing 2" from the face of the traffic side in accordance with Specification Section 705. Match the Barrier Delineator to the color (white or yellow) of the near edgeline.
9. Traffic Railing Transitions:
  - A. Transition to guardrail: see Detail "A" and View B-B.
  - B. Transition to 38" Concrete Barriers: See Detail "B" and View C-C.
10. See Superstructure Plans for drainage slot locations and size (when required)
11. For embedded conduit and junction boxes see Index 630-010. For Traffic Railings with Pedestrian/Bicycle Bullet Railings see Index 515-021 and 515-022 for notes, details and post spacing.

SDATES

LAST REVISION 11/01/20	REVISION	DESCRIPTION:	 <b>FY 2021-22 STANDARD PLANS</b>	<b>TRAFFIC RAILING - (36" SINGLE-SLOPE)</b>	INDEX 521-427	SHEET 1 of 5
---------------------------	----------	--------------	--	---	------------------	-----------------

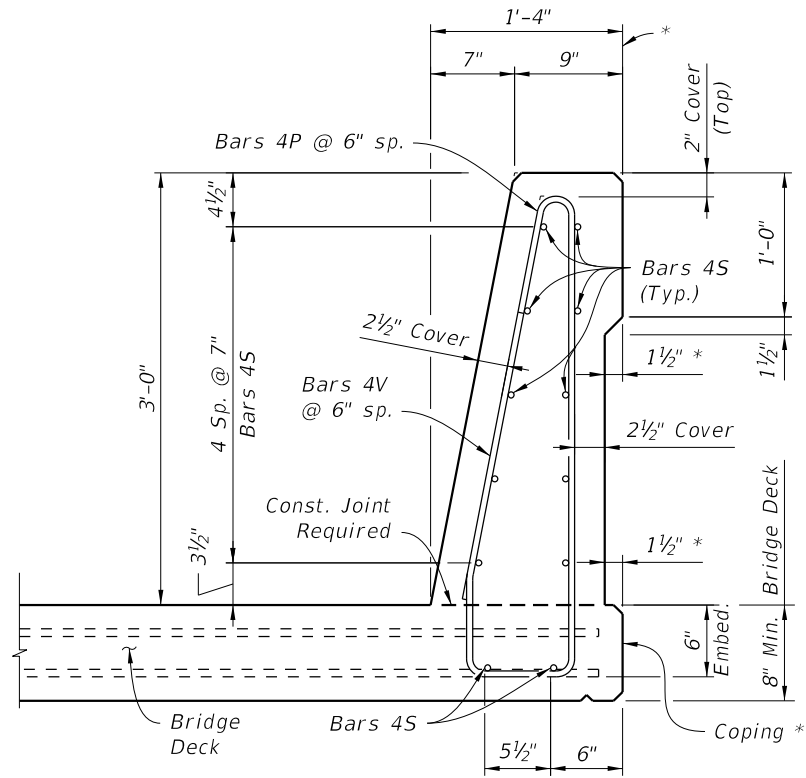

\* Where railings of adjacent bridges are to be built back to back, the outside vertical plane of the railing and deck/approach slab may coincide along a plane centered 1'-4" from each gutter line. A bond breaker will be required. See Structures Plans, Superstructure Sheets for Details.

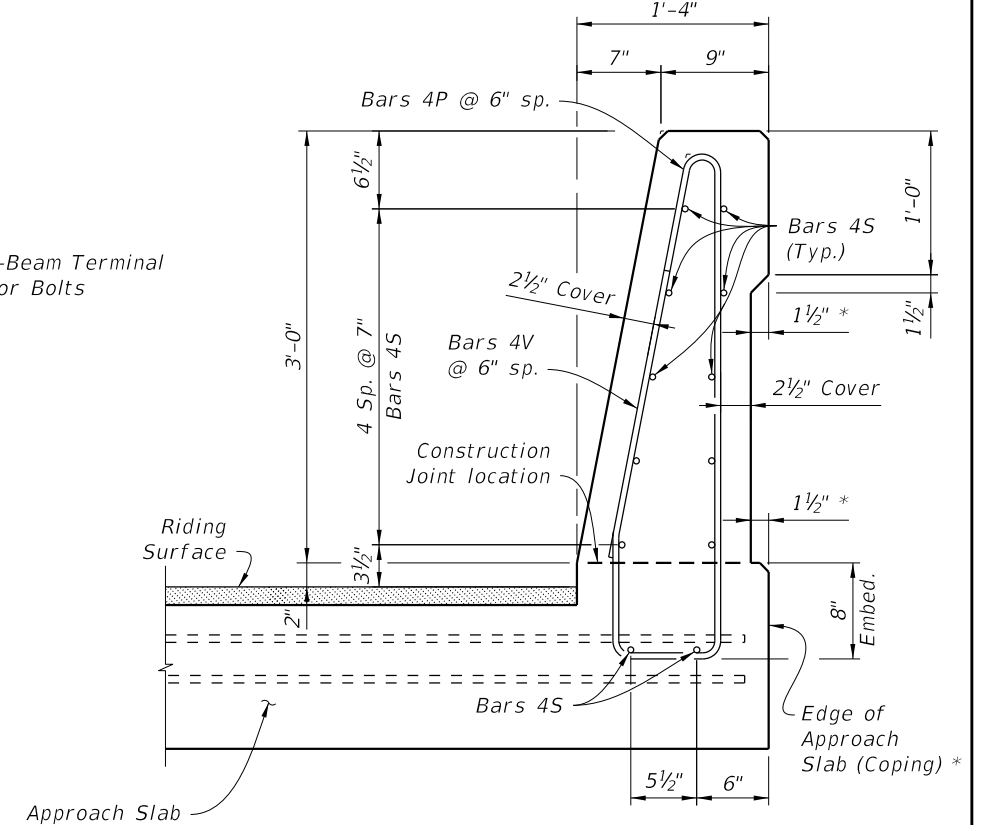
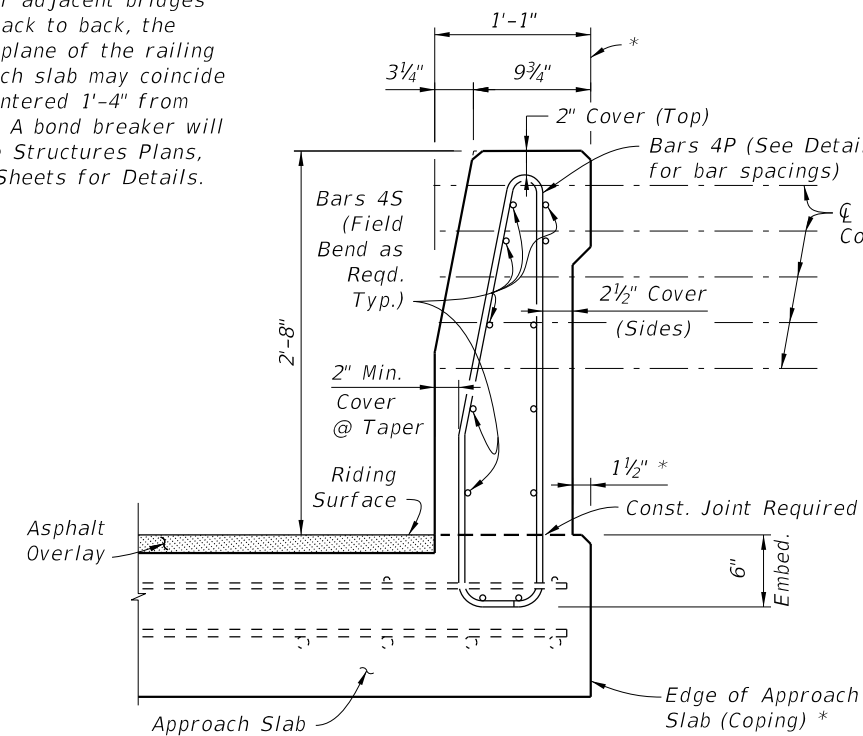

**SECTION A-A**  
TYPICAL SECTION THRU TRAFFIC RAILING  
(Section thru Bridge Deck shown, Section thru Approach Slab and Retaining Walls similar)

**VIEW B-B**  
END TRANSITION  
(Section thru Approach Slab shown, Section thru Retaining Walls similar)

**VIEW C-C**  
HEIGHT TRANSITION

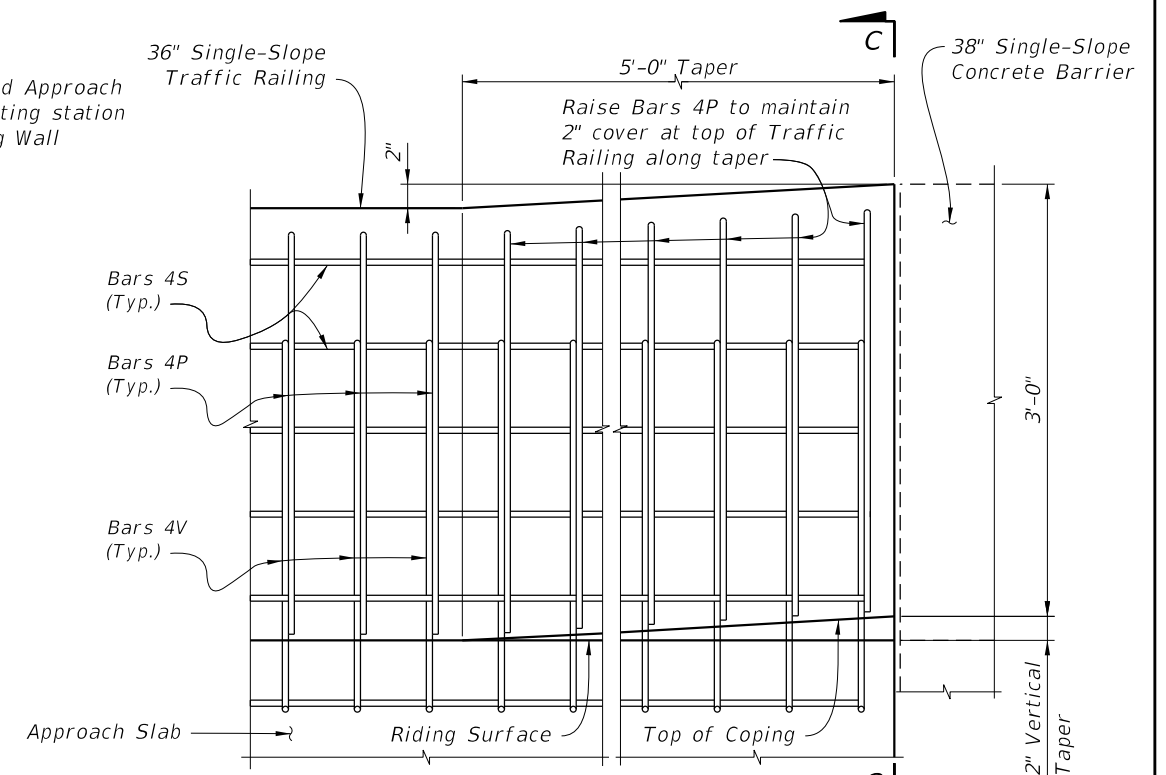
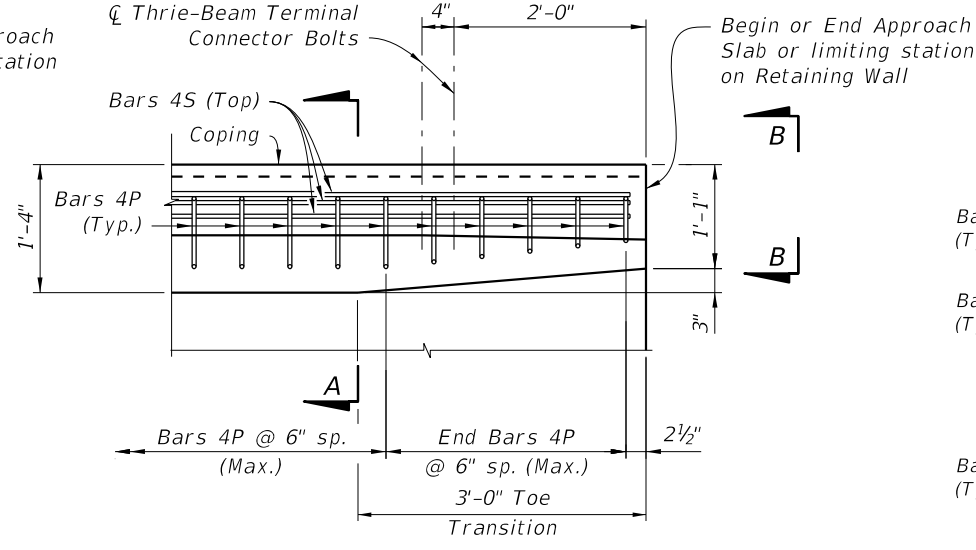
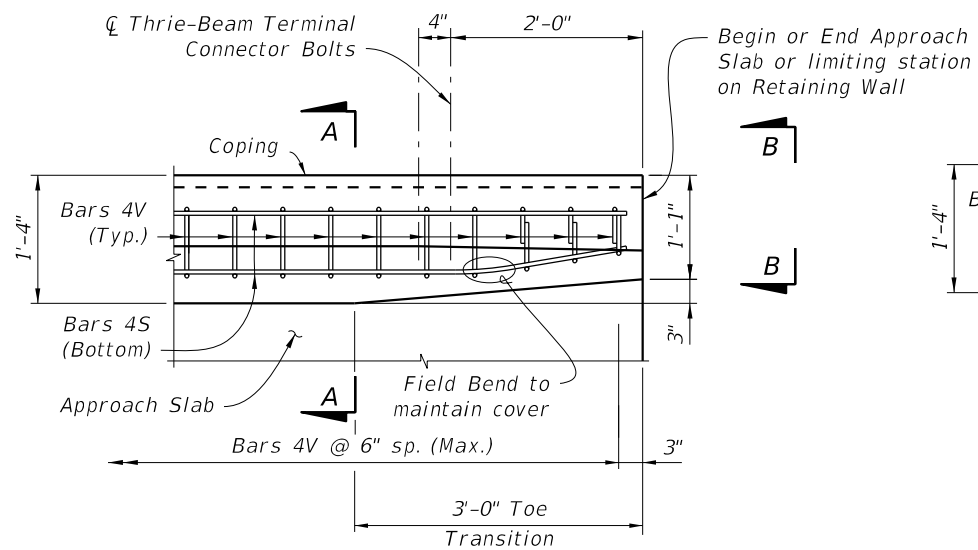

**DETAIL "B"**  
ELEVATION - RAILING HEIGHT TRANSITION  
(Showing Transition to Index 521-001 38" Single-Slope Concrete Barrier)

NOTES: Omit Detail "A" and provide Detail "B" if Index 521-001 Concrete Barrier is used beyond the Approach Slab;  
See Structures Plans, Plan and Elevation Sheet and Roadway Plans.  
Detail "B" is not required when transitioning to Index 521-610.  
If Transitions A or B are not required, extend Typical Section to end of the Approach Slab.

DETAIL "A"

10/8/2020 9:57:32 AM

LAST REVISION 11/01/20	DESCRIPTION:	FDOT FY 2021-22 STANDARD PLANS	TRAFFIC RAILING - (36" SINGLE-SLOPE)	INDEX 521-427	SHEET 2 of 5
---------------------------	--------------	--------------------------------------	--------------------------------------	------------------	-----------------

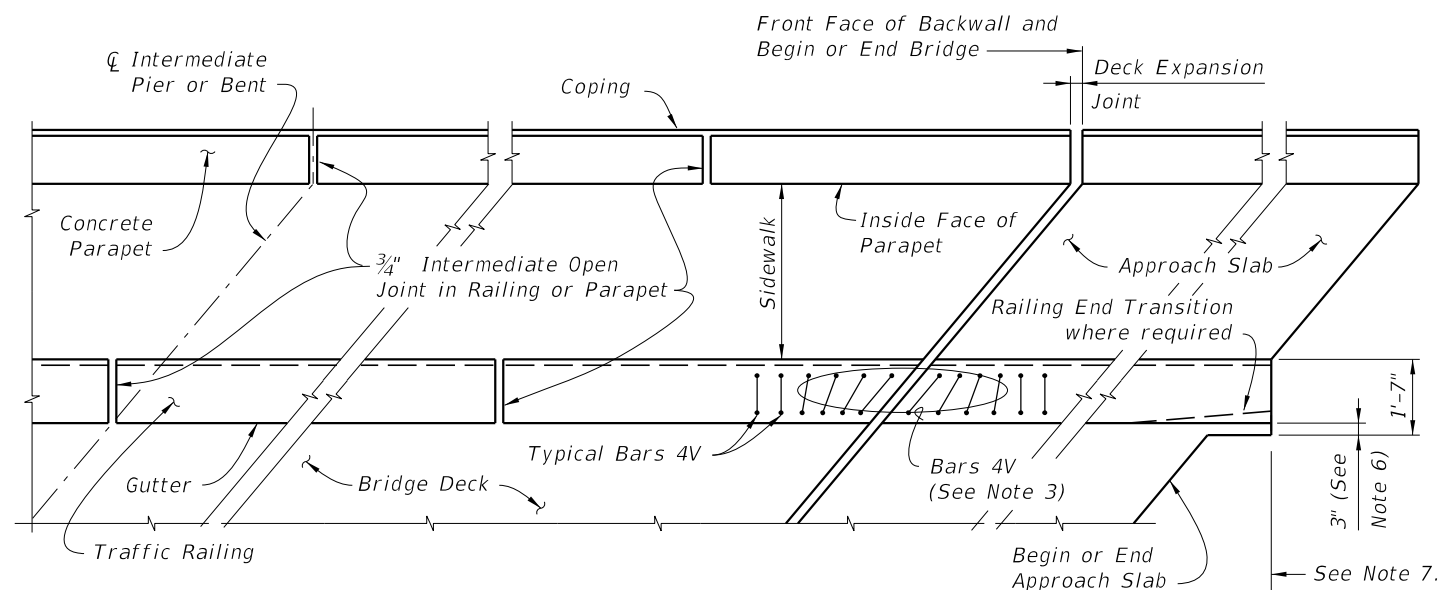

PARTIAL PLAN VIEW OF SKEWED BRIDGE DECK AND APPROACH SLAB WITH SIDEWALK, SINGLE-SLOPE TRAFFIC RAILING AND PEDESTRIAN/BICYCLE RAILING  
INDEX 521-820 or 521-825, OTHER TRAFFIC RAILINGS SIMILAR

NOTES:

- 1) Concrete Parapet reinforcement is not effected by skew angle, see Index 521-820 for details.
- 2) Parapet expansion joint shall match the deck expansion joint which shall be turned perpendicular or radial to the gutter line. See Structures Plans, Superstructure Sheets for details.
- 3) Traffic Railing reinforcement vertical Bars 4V & 4P may be shifted up to 1" (Max.) and rotated up to 10 degrees as required to allow proper placement. Bars 4V adjacent to expansion joints shall be field adjusted to maintain clearance and spacing, extra Bars 4V will be required. Cut bottom horizontal portion of 4V Bars to maintain maximum horizontal length to each vertical leg being placed. Discard the remainder of the bar. Rotate cut bars to maintain clearance.
- 4) Railing ends at deck expansion joints shall follow the deck joint with allowance for joint movement. Expansion joint at the inside face of parapet shall be turned perpendicular or radial to this line. See Structures Plans, Superstructure and Approach Slab Sheets for details.
- 5) 3/4" Intermediate Open Joints and V-Grooves in railing and parapet shall be placed perpendicular or radial to the gutter line or inside face of parapet line. See Structures Plans, Superstructure Sheets for locations.
- 6) At begin or end approach slab extend slab at the railing ends 3" (gutter side or back face of railing as required) as shown to provide a base for casting of the railing. Field trim toe of Bars 4V by 1 inch as required to maintain concrete cover at edge of deck.
- 7) When Guardrail is shown on the approach, begin placing Railing Bars 4P and 4V on Approach Slab at the railing end and proceed toward Begin or End Bridge to ensure placement of guardrail bolt holes. If required, adjustments to the bar spacing for Bars 4P and 4V shall be made immediately adjacent to Begin or End Bridge.

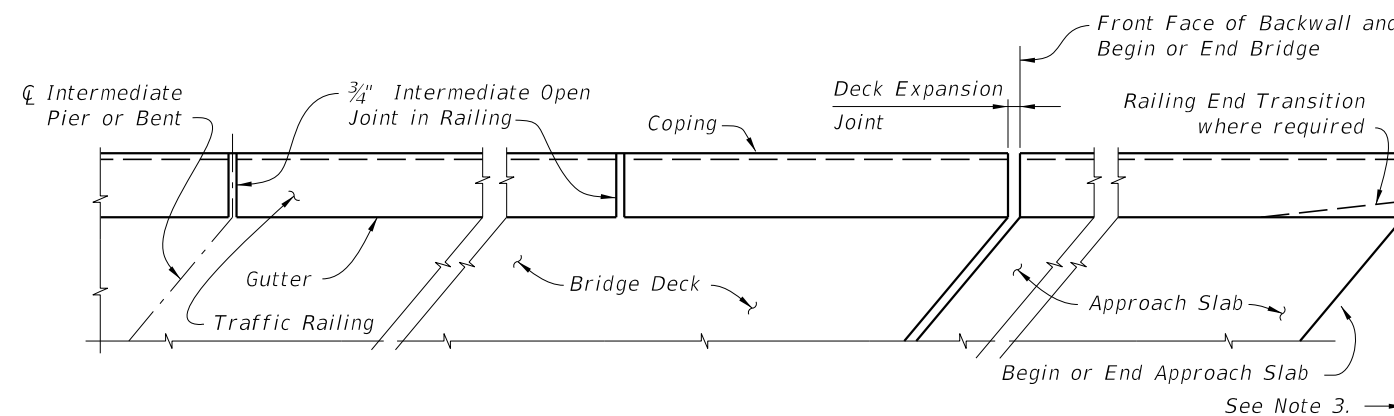

PARTIAL PLAN VIEW OF SKEWED BRIDGE DECK AND APPROACH SLAB WITH SINGLE-SLOPE TRAFFIC RAILING, OTHER TRAFFIC RAILINGS SIMILAR

NOTES:

- 1) Railing expansion joint shall match the deck expansion joint which shall be turned perpendicular or radial to the gutter line. See Structures Plans, Superstructure Sheets for details.
- 2) 3/4" Intermediate Open Joints and 1/2" V-Grooves in railing shall be placed perpendicular or radial to the gutter line. See Structures Plans, Superstructure and Approach Slab Sheets for locations.
- 3) When Guardrail is shown on the approach, begin placing Railing Bars 4P and 4V on Approach Slab at the railing end and proceed toward Begin or End Bridge to ensure placement of guardrail bolt holes. If required, adjustments to the bar spacing for Bars 4P and 4V shall be made immediately adjacent to Begin or End Bridge.

GENERAL NOTES:

- 1) Work this Sheet with Traffic Railing, Pedestrian/Bicycle Railing, and Approach Slab Indexes as applicable.
- 2) Deck Expansion Joint at begin or end bridge shown. Deck Expansion Joints at Intermediate Piers or Intermediate Bents are similar.
- 3) Partial Plan Views shown are intended as guides only. See Structures Plans, Superstructure and Approach Slab Sheets for skew angles, joint orientation, dimensions and details.
- 4) Railings on Raised Sidewalks shall be treated similar to the Partial Plan View of Bridge Deck with Traffic Railing.
- 5) If Welded Wire Reinforcement is used in lieu of conventional reinforcement, placement of the WWR vertical elements shall be similar to those shown above. Clipping of horizontal elements to facilitate placement shall be minimized where possible. When clipping is required, supplement horizontal elements by lap splicing with deformed bars having an equivalent area of steel.

10/8/2020 9:57:34 AM

LAST REVISION 11/01/17	REVISION	DESCRIPTION:	 FY 2021-22 STANDARD PLANS	TRAFFIC RAILING - (36" SINGLE-SLOPE)	INDEX 521-427	SHEET 3 of 5
---------------------------	----------	--------------	---	--------------------------------------	------------------	-----------------

ALTERNATE REINFORCING STEEL (WWR) DETAILS

CONVENTIONAL REINFORCING STEEL BENDING DIAGRAMS

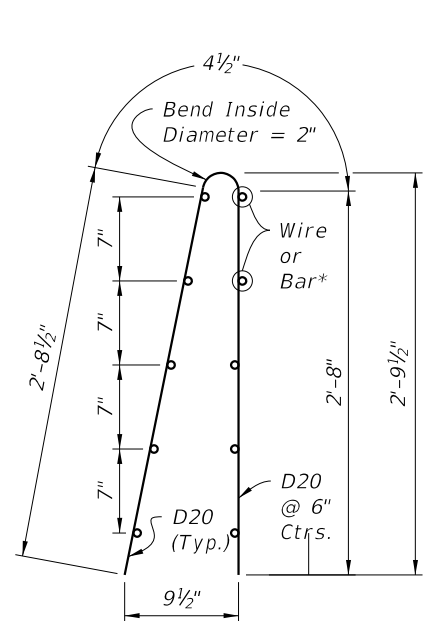

WWR Piece No. 2

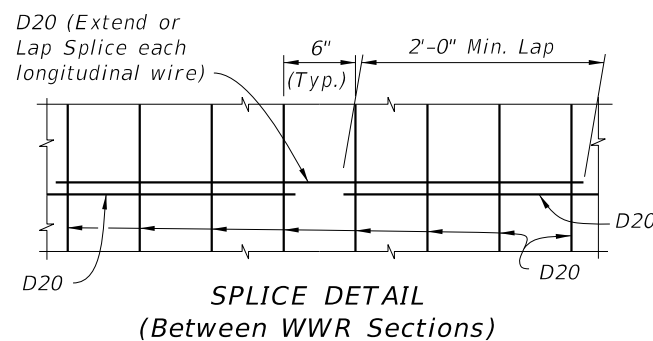

SPLICE DETAIL (Between WWR Sections)

WELDED WIRE REINFORCEMENT NOTES:

1. At the option of the Contractor deformed Welded Wire Reinforcement (WWR) may be utilized in lieu of all Bars 4P, 4S and 4V. WWR must consist of Deformed wire meeting the requirements of Specification Section 931.
2. WWR at Railing End Transition shall be field bent inward as required (Piece 2) to maintain cover. The bottom of the vertical wires (D20) in Piece 2 shall be cut a maximum of 4 inches and the gutter side portion bent inward as required to allow placement.

\* Longitudinal D20 Wires or #4 Bars may be tied.

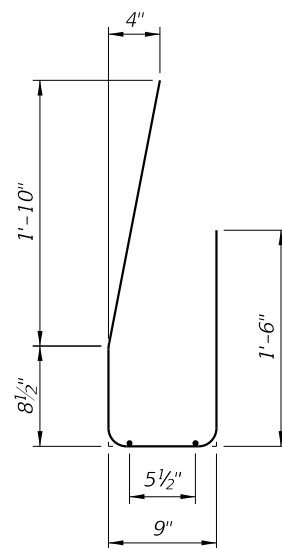

WWR Piece No. 1

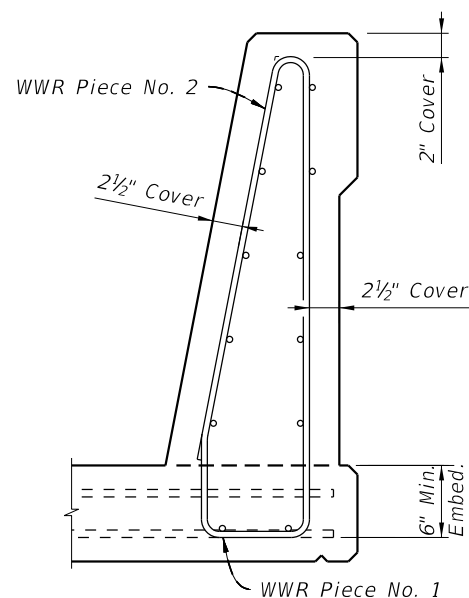

WWR Piece No. 1

ROADWAY CROSS-SLOPE	LOW GUTTER	HIGH GUTTER
	0% to 2%	ØB
2% to 6%	90°	90°
6% to 10%	87°	93°
	84°	96°

ØB shall be 90° if Contractor elects to place railing perpendicular to the deck and approach slabs.

BILL OF REINFORCING STEEL		
MARK	SIZE	LENGTH
P	4	5'-11"
S	4	As Req'd.
V	4	4'-10"

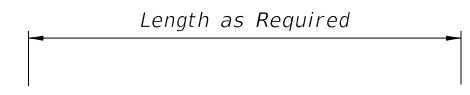

BAR 4S

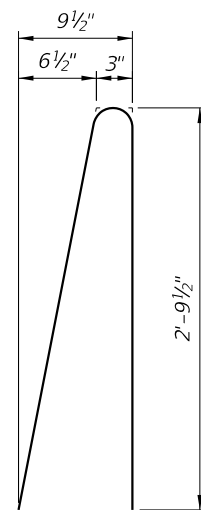

STIRRUP BAR 4P

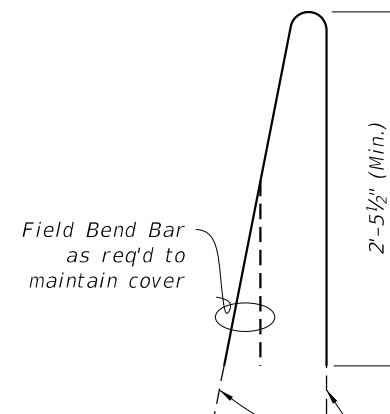

END STIRRUP BAR 4P To Be Field Cut and Bent

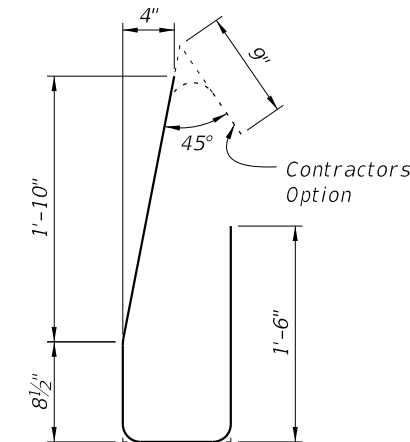

BAR 4V

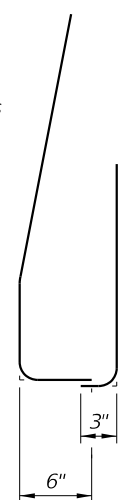

END TRANSITION BAR 4V Field Cut and Lapped

REINFORCING STEEL NOTES:

1. All bar dimensions in the bending diagrams are out to out.
2. The 8 1/2 inch vertical dimensions shown for Bar 4V is based on a 6 inch embedment into the bridge deck without a raised sidewalk. If a raised sidewalk is to be provided, increase this dimension to achieve a 6 inch minimum embedment into the bridge deck. See Structures Plans, Superstructure and Approach Slab Sheets.
3. All reinforcing steel at the open joints shall have a 2 inch minimum cover.
4. Bars 4S may be continuous or spliced at the construction joints. Bar splices for Bars 4S shall be a minimum of 2'-0 inch.

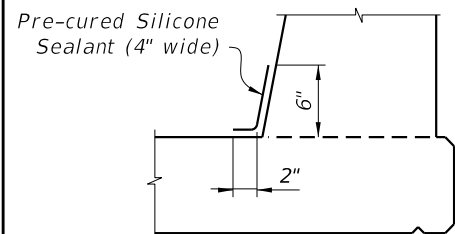

DETAIL "C" - SECTION AT INTERMEDIATE OPEN JOINT

INTERMEDIATE JOINT SEAL NOTES:

1. At Intermediate Open Joints, seal the lower 6 inch portion of the open joint with Pre-cured Silicone Sealant in accordance with Specification Section 932.
2. Apply sealant prior to any Class V finish coating and remove all curing compound and loose material from the surface prior to application of bonding agent.
3. Include the cost of the Pre-cured Silicone Sealant in the Contract Unit Price for the Traffic Railing.

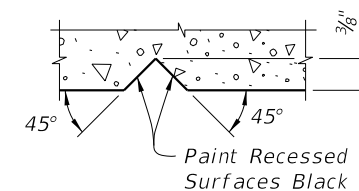

SECTION THRU RECESSED "V" GROOVE TO FORM INSCRIBED LETTERS AND FIGURES

ESTIMATED TRAFFIC RAILING QUANTITIES		
ITEM	UNIT	QUANTITY
Concrete	CY/LF	0.107
Reinforcing Steel	LB/LF	24.78

(The above quantities are based on a 2% deck cross slope; railing on low side of deck.)

10/8/2020 9:57:36 AM

LAST REVISION	DESCRIPTION:
11/01/17	

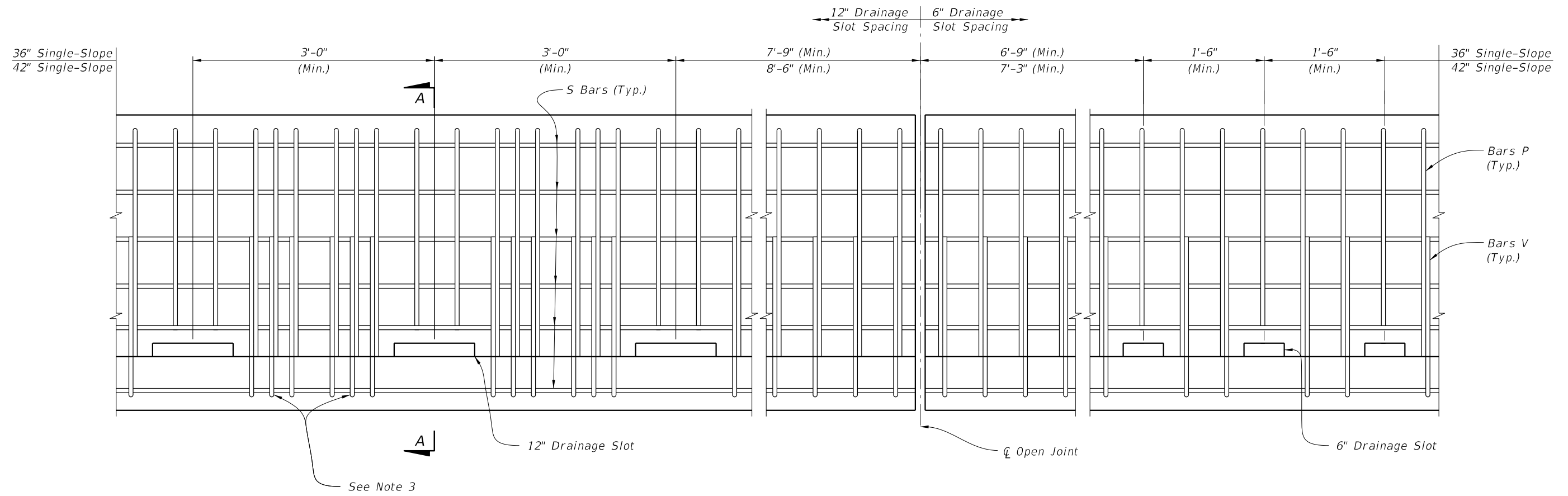

ELEVATION

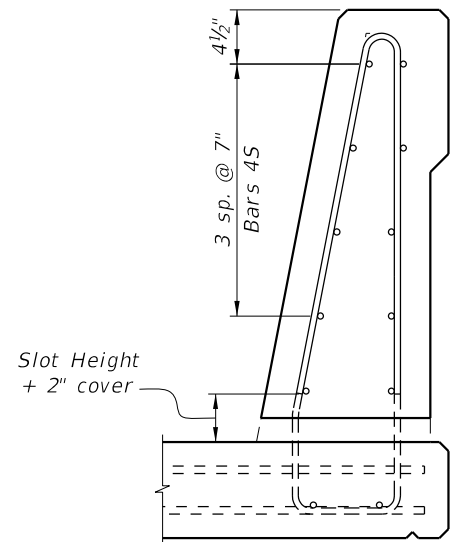

SECTION A-A  
36" Single-Slope Shown  
Other traffic railings similar

DRAINAGE SLOT NOTES:

1. Use only when required for safety. See Plans for locations and size of drainage slots.
2. Maintain 2" minimum cover to all reinforcing. Trim P Bars over drainage slots and raise bottom S bars as necessary to maintain cover.
3. For slots greater than 6" in length, add additional vertical bars (V & P) on each side of the opening.
4. Drainage slot heights are 2" or 3". See the plans for size and location details.

10/8/2020 9:57:38 AM

LAST REVISION 11/01/19	REVISION	DESCRIPTION:
---------------------------	----------	--------------



FY 2021-22  
STANDARD PLANS

TRAFFIC RAILING - (36" SINGLE-SLOPE)

INDEX  
521-427

SHEET  
5 of 5