

TYPE E  
TYPE F  
CURB AND GUTTER

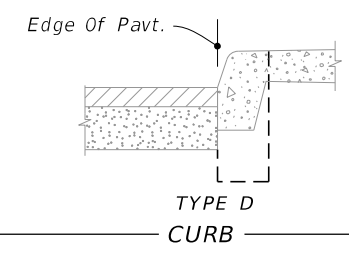

TYPE A  
TYPE B  
TYPE D  
CURB  
MEDIAN CURB AND TRAFFIC  
SEPARATOR JUNCTURE DETAILS

(Option I Separator Shown, For Curb Details see Index 520-001)

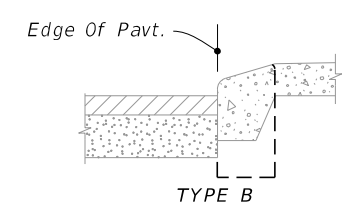
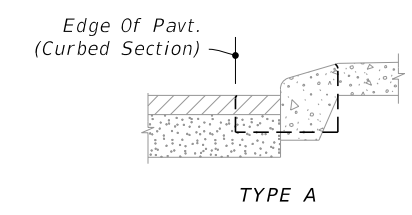
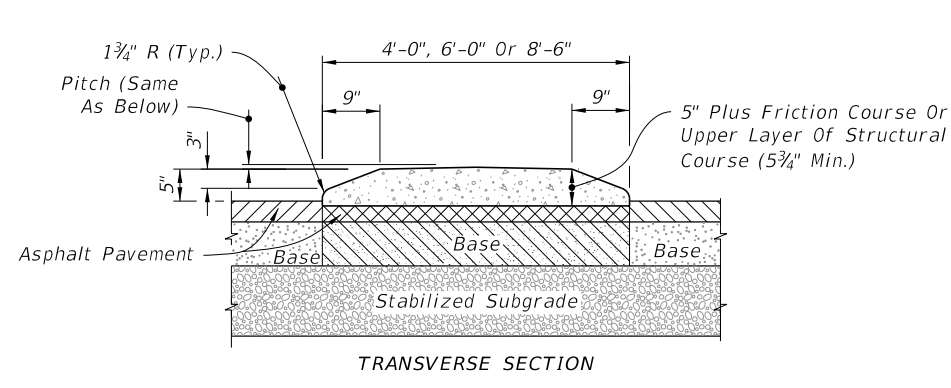
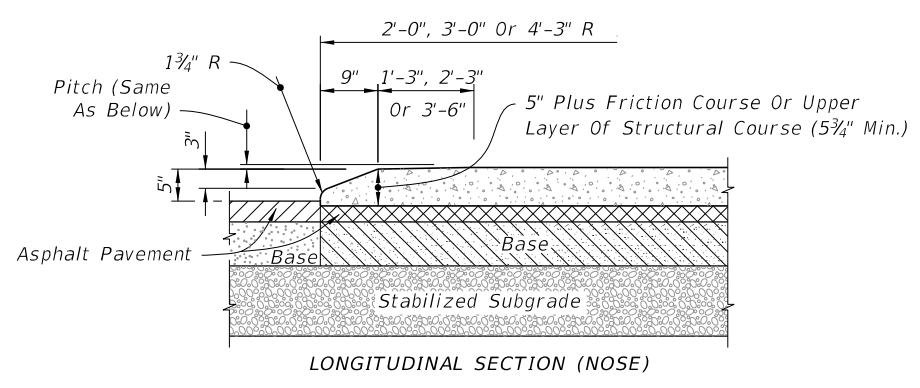
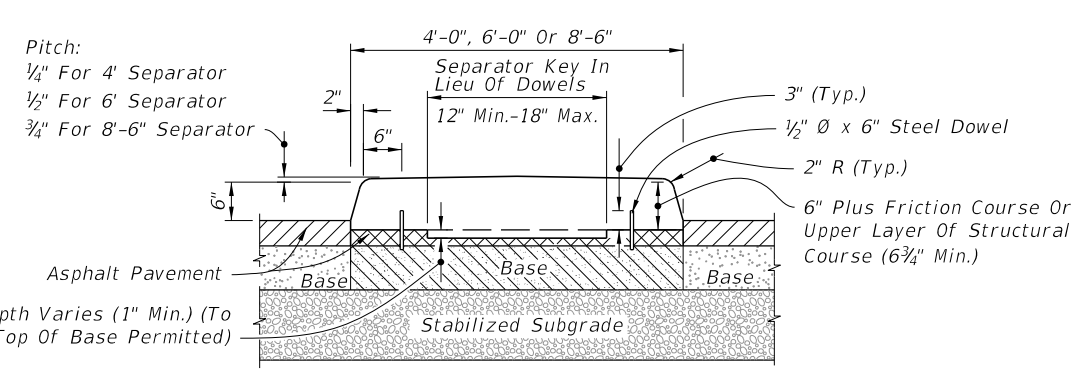
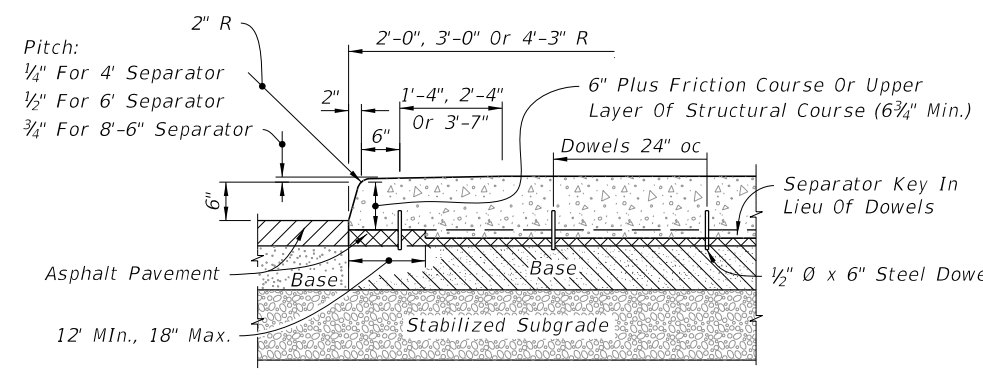
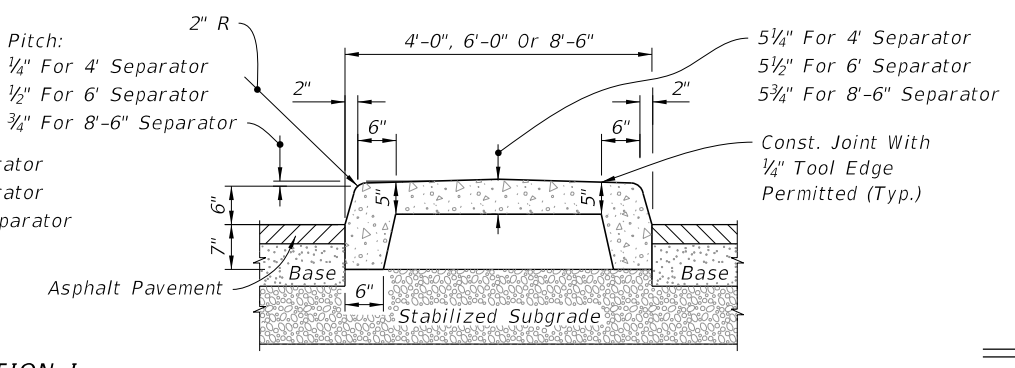
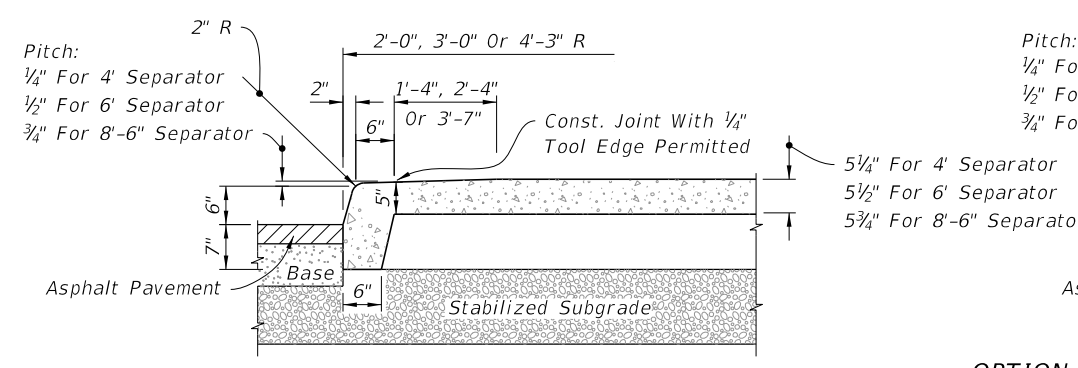

NOTES:

1. Separators Type I and IV are to be used with flexible pavement. Separators Types II and V are to be used with rigid pavement.
2. Either Option I or Option II may be used for Types I and IV separators except when a specific option is called for in the Plans.
3. For all separators provide 1/8"- 1/4" contraction joints at 10' centers (max.). Contraction joints adjacent to concrete pavement on tangents and flat curves to match the pavement joints, with intermediate joints not to exceed 10' center.

OPTION I  
OPTION II  
TYPE IV - CONCRETE TRAFFIC SEPARATOR

ROADWAY INSTALLATIONS - FLEXIBLE PAVEMENT

10/12/2020 7:33:52 AM

LAST REVISION 11/01/17	DESCRIPTION:	FDOT	FY 2021-22 STANDARD PLANS	TRAFFIC SEPARATORS	INDEX 520-020	SHEET 1 of 5
---------------------------	--------------	------	------------------------------	--------------------	------------------	-----------------

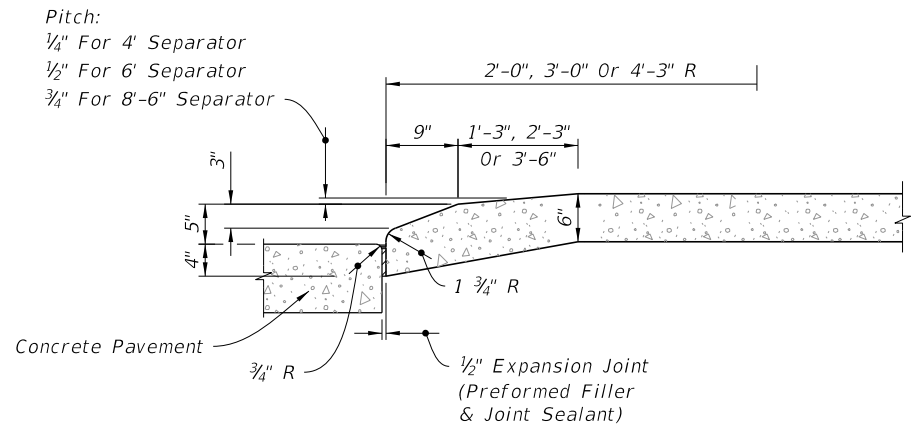

LONGITUDINAL SECTION (NOSE)

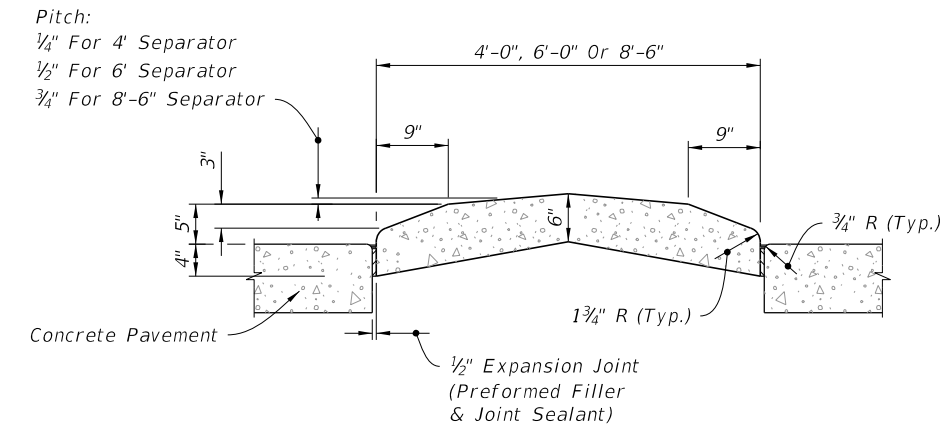

TRANSVERSE SECTION

TYPE II - CONCRETE TRAFFIC SEPARATOR

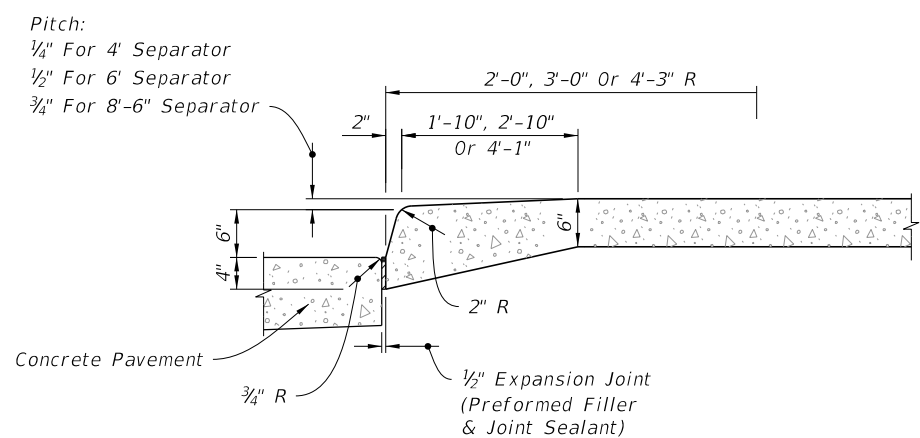

LONGITUDINAL SECTION (NOSE)

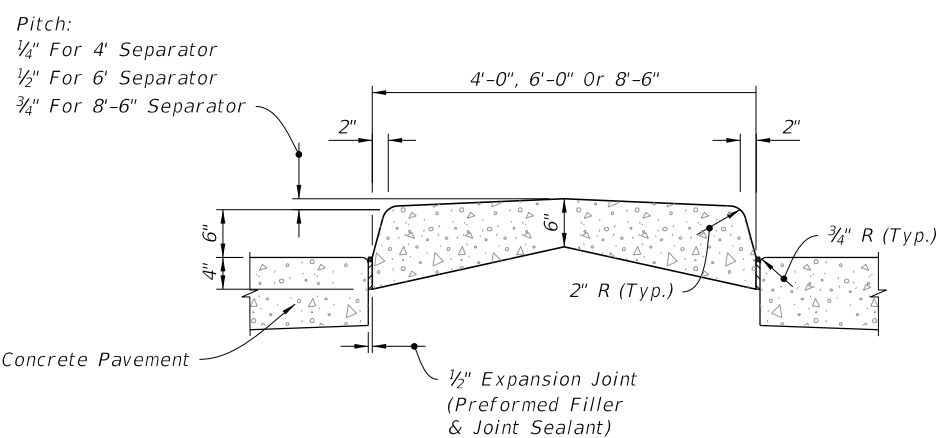

TRANSVERSE SECTION

TYPE V - CONCRETE TRAFFIC SEPARATOR

ROADWAY INSTALLATIONS - RIGID PAVEMENT

10/12/2020 7:33:55 AM

LAST REVISION 11/01/17	REVISION	DESCRIPTION:	 FY 2021-22 STANDARD PLANS	TRAFFIC SEPARATORS	INDEX 520-020	SHEET 2 of 5
---------------------------	----------	--------------	---	--------------------	------------------	-----------------

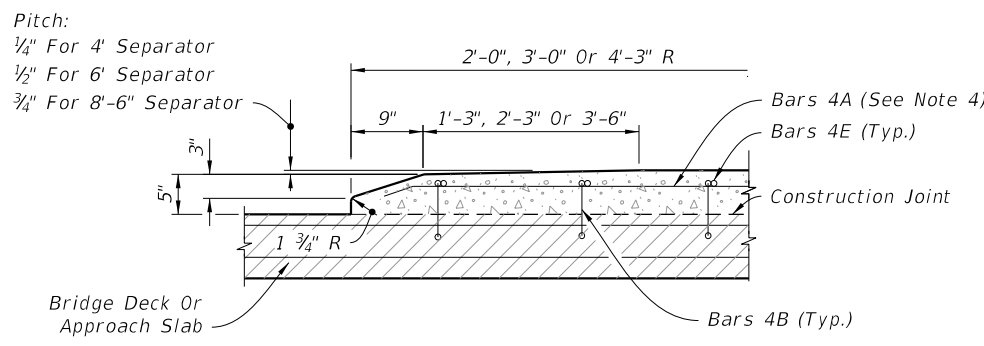

LONGITUDINAL SECTION (NOSE)

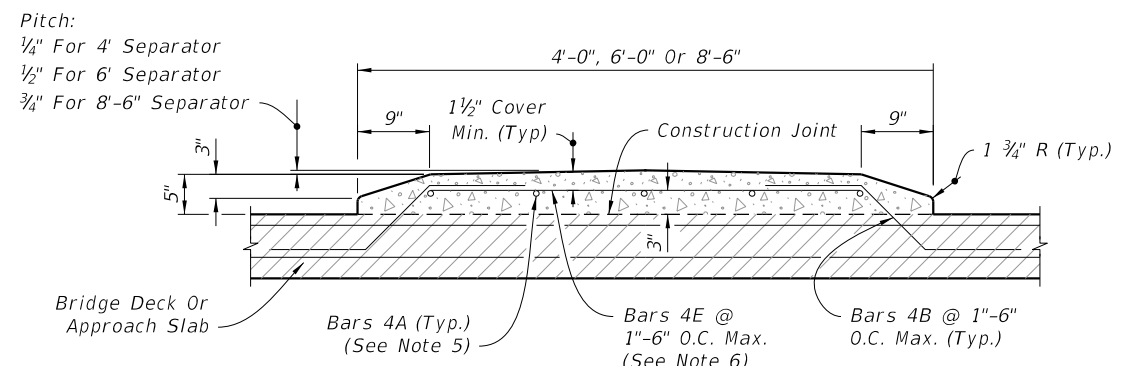

TRANSVERSE SECTION

OPTION I

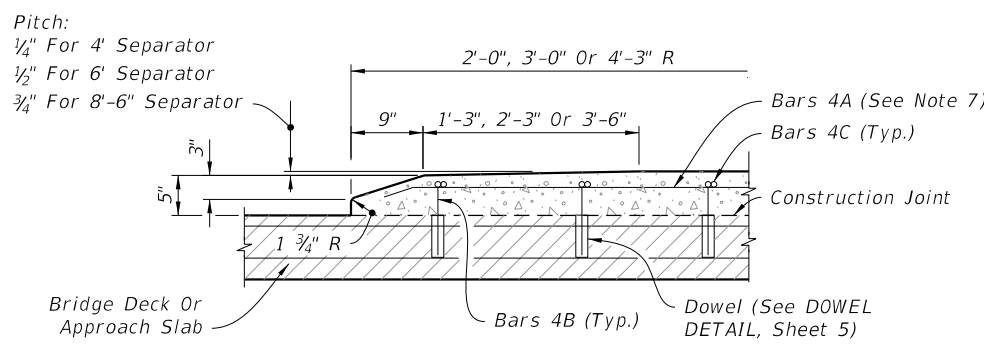

LONGITUDINAL SECTION (NOSE)

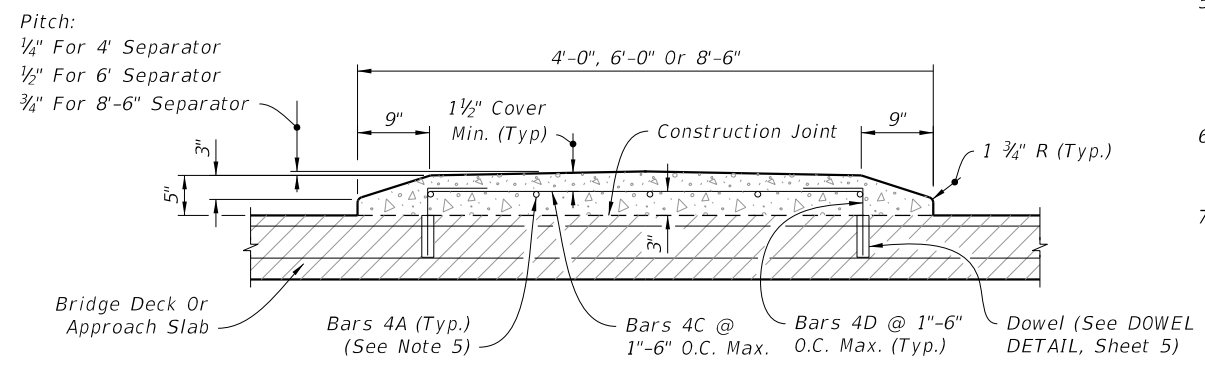

TRANSVERSE SECTION

OPTION II

NOTES:

1. Traffic Separator transverse reinforcement adjacent to deck expansion joints shall be field adjusted to maintain clearance and spacing. Bars shall be field cut as shown, bars may be rotated to maintain clearance.
2. Traffic Separator ends at deck expansion joints shall follow the deck joint limits. Drainage joints and b" V-Grooves shall be placed perpendicular or radial to the  $\phi$  of the Traffic Separator. See Structures Plans, Superstructure and Approach Slab Sheets for details.
3. See Structures Plans, Superstructure Sheets for actual dimensions and joint orientation.
4. Option II is not permitted on bridge decks with prestressing steel.
5. Bar Spacing:  
 4'-0" @ 3 equal spaces (continuous)  
 6'-0" @ 5 equal spaces (continuous)  
 8'-6" @ 7 equal spaces (continuous)
6. At the Contractor's option, a one piece bar may be substituted for Bars 4B and 4E.
7. Field bend and cut rebar as required to maintain cover.

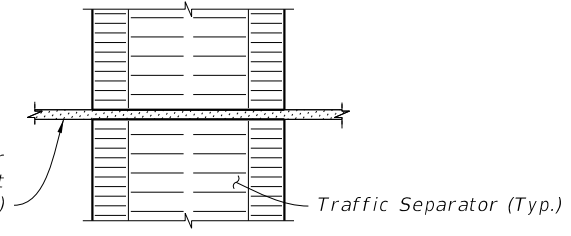

DETAIL AT Poured Joint With Backer Rod Expansion Joints

REINFORCING STEEL  
(Bridge Deck Shown, Approach Slab Similar)

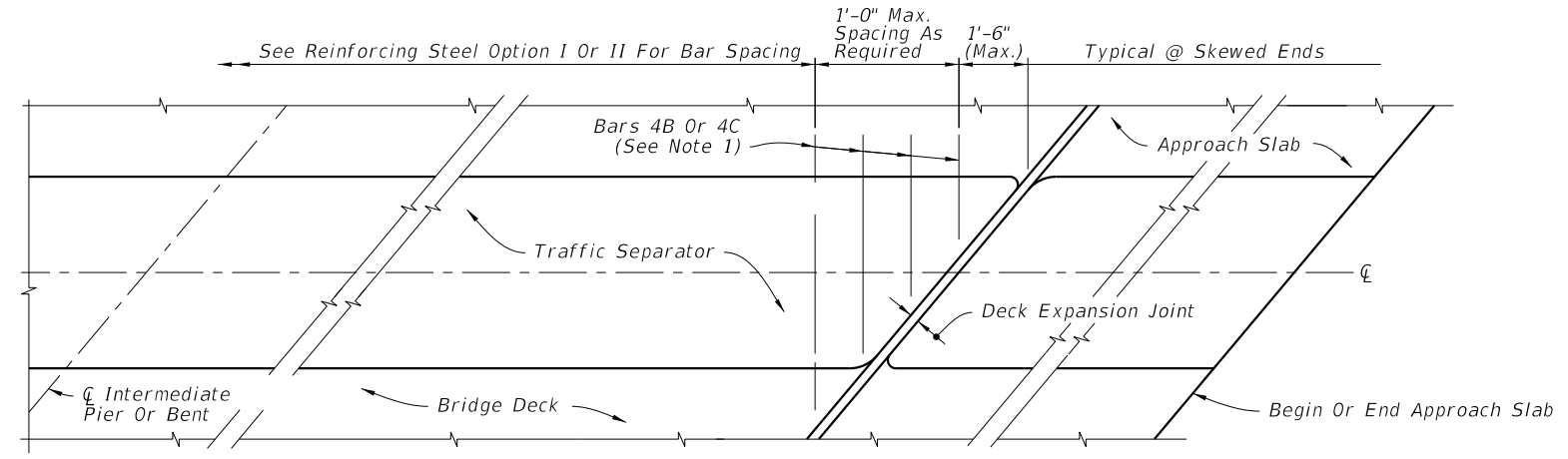

SKEWED BRIDGE DECK AND APPROACH SLAB WITH TRAFFIC SEPARATOR  
(Deck Expansion Joint at Begin or End Bridge Shown, Expansion Joint at  $\phi$  Pier or Intermediate Bents Similar)

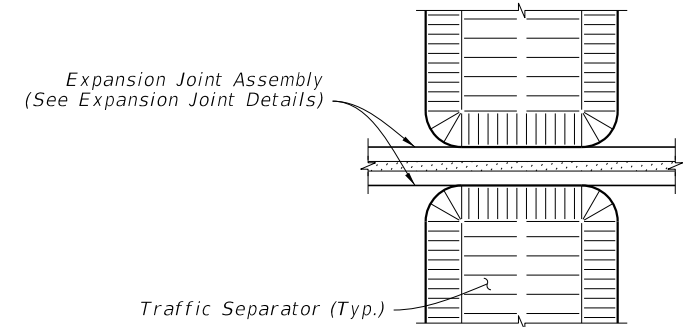

DETAIL AT EXPANSION JOINTS  
(Strip Seal Shown, Other Armored Joint Types Similar)

BRIDGE INSTALLATIONS - TYPE "E" CURB

4/27/2021 12:29:46 PM

LAST REVISION 11/01/17	DESCRIPTION:	 FY 2021-22 STANDARD PLANS	TRAFFIC SEPARATORS	INDEX 520-020	SHEET 3 of 5
---------------------------	--------------	--	--------------------	------------------	-----------------

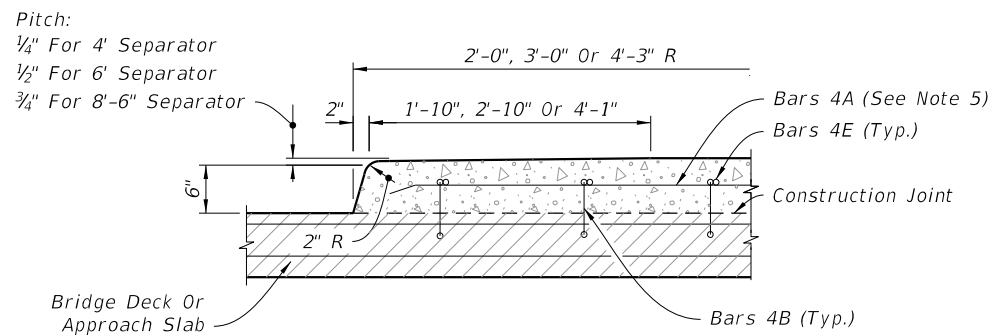

LONGITUDINAL SECTION (NOSE)

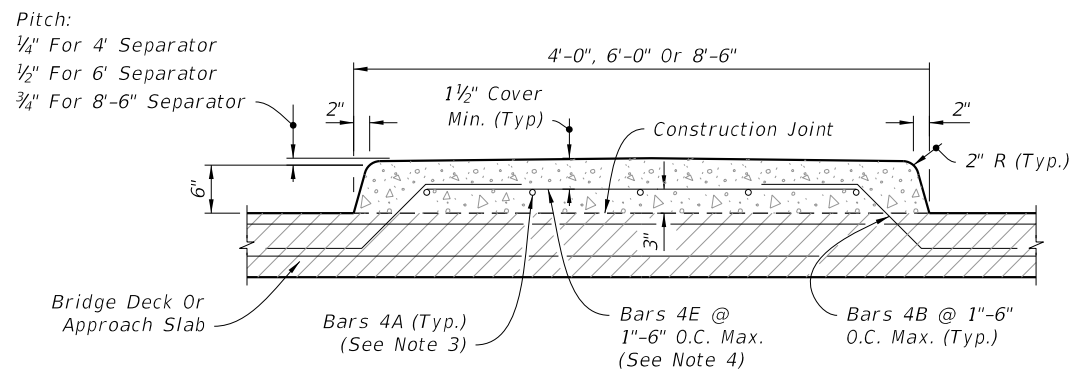

TRANSVERSE SECTION

OPTION I

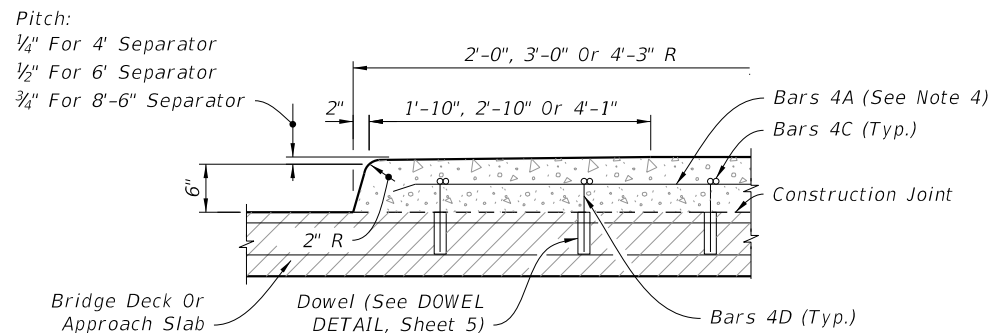

LONGITUDINAL SECTION (NOSE)

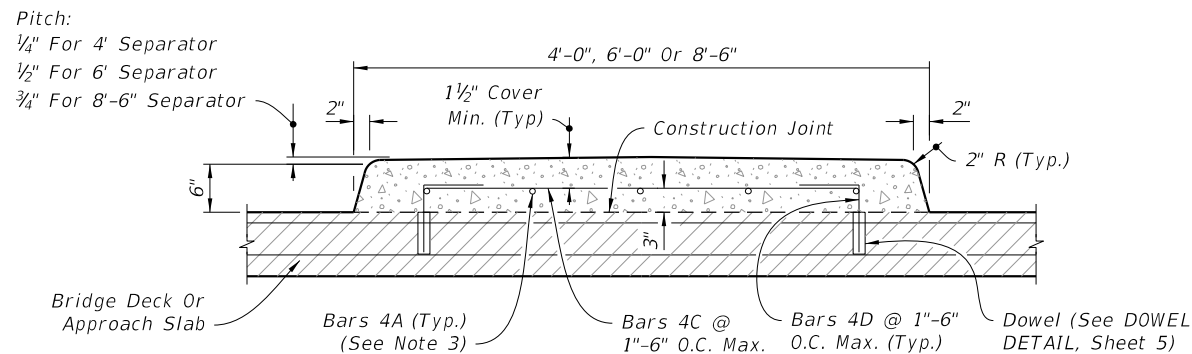

TRANSVERSE SECTION

OPTION II

REINFORCING STEEL

(Bridge Deck Shown, Approach Slab Similar)

Expansion Joint Assembly  
 (See Expansion Joint Details)

Traffic Separator (Typ.)

DETAIL AT EXPANSION JOINTS

(Strip Seal Shown, Other Armored Joint Types Similar)

Poured Joint With Backer  
 Rod Expansion Joint  
 (See Expansion Joint Details)

Traffic Separator (Typ.)

DETAIL AT POURED JOINT WITH  
 BACKER ROD EXPANSION JOINTS

NOTES:

1. Treatment of separators on straight bridges shown. For additional notes and treatment of separators on skewed bridges, see Sheet 2.
2. Option II is not permitted on bridge decks with prestressing steel.
3. Bar Spacing:  
 4'-0" @ 3 equal spaces (continuous)  
 6'-0" @ 5 equal spaces (continuous)  
 8'-6" @ 7 equal spaces (continuous)
4. At the Contractor's option, a one piece bar may be substituted for Bars 4B and 4E.
5. Field bend and cut rebar as required to maintain cover.

4/27/2021 12:29:49 PM

LAST REVISION 11/01/17	DESCRIPTION:
---------------------------	--------------



FY 2021-22  
 STANDARD PLANS

TRAFFIC SEPARATORS

INDEX  
 520-020

SHEET  
 4 of 5

BRIDGE INSTALLATIONS - TYPE "F" CURB

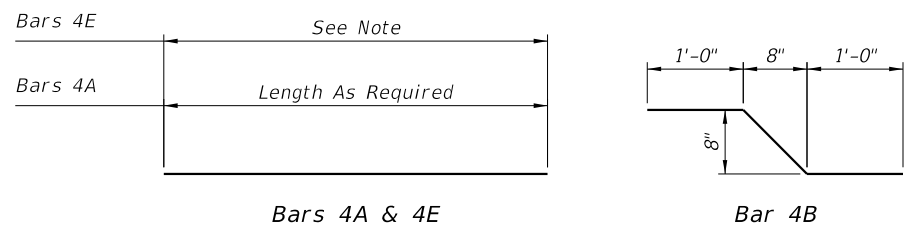

Bars 4A & 4E

Bar 4B

**NOTE:**

Length of Bars 4E is 2'-5" for 4'-0" Separator.  
 Length of Bars 4E is 4'-5" for 6'-0" Separator.  
 Length of Bars 4E is 6'-11" for 8'-6" Separator.

**OPTION I**

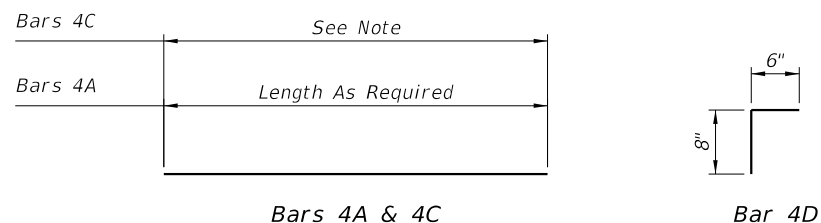

Bars 4A & 4C

Bar 4D

**NOTE:**

Length of Bars 4C is 2'-4½" for 4'-0" Separator.  
 Length of Bars 4C is 4'-4½" for 6'-0" Separator.  
 Length of Bars 4C is 6'-10½" for 8'-6" Separator.

**OPTION II**

**REINFORCING STEEL NOTES:**

- All dimensions are out to out.
- The 8" vertical dimension shown for Bars 4B and 4D are based on a slab 8½" thick or greater without a wearing surface. If slab thickness is less than 8½", decrease this dimension by an amount equal to the difference in thickness. If a wearing surface is to be provided, increase this dimension by an amount equal to the wearing surface thickness.

**CONVENTIONAL REINFORCING STEEL BENDING DIAGRAMS**

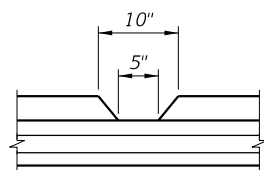

See Structures Plans, Superstructure Sheets for location(s) of drainage joints. Locations for drainage joints shall be limited to the constant width section of separator.

**DRAINAGE JOINT DETAIL**  
(For 5" Opening Or Less)

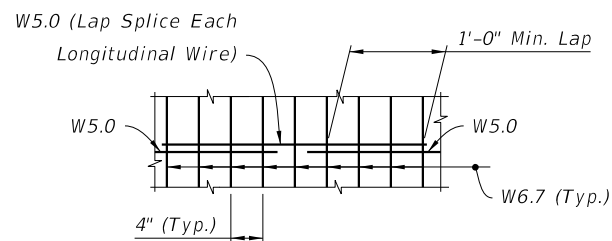

**SPLICE DETAIL**

(Between WWR 3 x 4 - W5.0 x W6.7 Sections)

**OPTION A:** Use Welded Wire Reinforcement 3 x 4 - W5.0 x W6.7 as required by plans in place of Bars 4A, 4B and 4E. Bend the Welded Wire Reinforcement to the dimensions of Bar 4B shown in the Bending Diagram for Reinforcing Steel Option I.

**OPTION B:** Use Welded Wire Reinforcement 3 x 4 - W5.0 x W6.7 as required by plans in place of Bars 4A and 4C shown in Reinforcing Steel Option II.

**NOTE:** Welded Wire Reinforcement to consist of smooth wire meeting the requirements of Specification 931.

**ALTERNATE REINFORCING STEEL DETAILS**  
(Welded Wire Reinforcement)

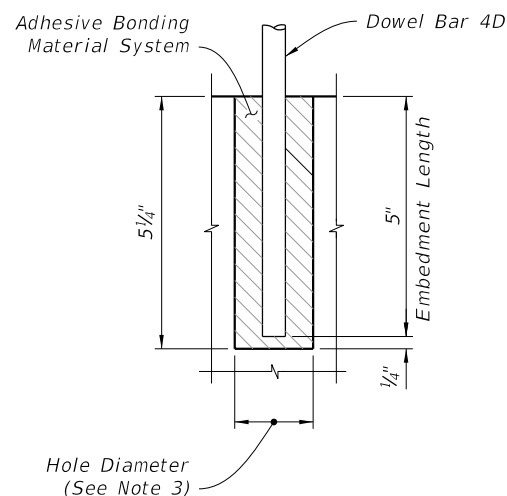

**DOWEL NOTES:**

- Shift Dowel Holes to clear if existing reinforcement is encountered.
- Provide and install an adhesive bonding material system in accordance with Specifications 416 and 937.
- The dowel hole diameter is to meet adhesive bonding material system manufacturer's requirements.

**DOWEL DETAIL**

**ESTIMATED TRAFFIC SEPARATOR QUANTITIES:**

**CONCRETE:**

CONSTANT WIDTH OF SEPARATOR:

	TYPE "E"	TYPE "F"
4'-0" Width	0.056 CY per Ft.	0.072 CY per Ft.
6'-0" Width	0.089 CY per Ft.	0.112 CY per Ft.
8'-6" Width	0.132 CY per Ft.	0.164 CY per Ft.

**NOSE:**

	TYPE "E"	TYPE "F"
4'-0" Width	0.080 CY	0.109 CY
6'-0" Width	0.193 CY	0.257 CY
8'-6" Width	0.403 CY	0.536 CY

**REINFORCING STEEL:**

(All quantities are based on an 8½" slab.)

**OPTION I:**

4'-0" Width	6.37 Lbs. per Ft.
6'-0" Width	8.60 Lbs. per Ft.
8'-6" Width	11.05 Lbs. per Ft.

**OPTION II:**

4'-0" Width	4.77 Lbs. per Ft.
6'-0" Width	7.00 Lbs. per Ft.
8'-6" Width	9.45 Lbs. per Ft.

**BRIDGE INSTALLATIONS - TYPE "E" AND "F" CURB**

10/12/2020 7:34:02 AM

LAST REVISION	DESCRIPTION:
11/01/17	



FY 2021-22  
STANDARD PLANS

TRAFFIC SEPARATORS

INDEX  
520-020

SHEET  
5 of 5