

3D VIEW OF RAILING WITH TYPE 1 - PICKET INFILL PANEL
(42" Height shown, 48" Height Similar)

TABLE 1 - RAILING MEMBERS

MEMBER	DESIGNATION	OUTSIDE DIMENSION	WALL THICKNESS
Post "A"	HSS 2½ x 1½ x 1/8	2.50" x 1.50"	0.125"
Post "B"	HSS 2½ x 1½ x 3/16	2.50" x 1.50"	0.188"
Top Rail	2½" NPS (Sch. 10)	2.875"	0.120"
	HSS 3.000 x 0.120	3.000"	0.120"
End Hoops	2½" NPS (Sch. 10)	2.875"	0.120"
	HSS 3.000 x 0.120	3.000"	0.120"
Top Rail Joint/Splice Sleeves	HSS 2.500 x 0.125	2.500"	0.125"
Intermediate & Bottom Rail	HSS 2 x 2 x 3/16	2.00" x 2.00"	0.188" (1)
Int. & Bottom Rail Post Connection Sleeve	HSS 1.500 x 0.125	1.500"	0.125" (1)
Handrail Joint/Splice Sleeves	1" NPS (Sch. 40)	1.315"	0.133"
	HSS 1.500 x 0.125	1.500"	0.125"
Handrails	1½" NPS (Sch. 40)	1.900"	0.145"
Handrail Support Bar	¾" Ø Round Bar	0.750"	N/A
Pickets (Type 1 Infill Panel)	¾" Ø Round Bar	0.750"	N/A
Infill Panel Members (Types 2 - 5)	Varies (See Details)	Varies	Varies

TABLE 1 NOTES:

(1) 0.125" wall thickness permitted for rails with post spacings less than 5'-8", except that Post Connection Sleeve must be 1¼" NPS (Sch. 40).

NOTES

Notes:

- Shop Drawings are required; see Specification Section 515
- For bridge mounted railings work this Index with Index 515-051 Bridge Bicycle/Pedestrian Railing
- Materials:
 - Pipe Rails and Pickets: ASTM A500 Grade B, C or D, or ASTM A53 Grade B for standard weight pipe (Schedule 40) and ASTM A36 for bars.
 - Structural Tube: ASTM A500 Grade A, B, C, or D or ASTM A501
 - Steel Plate: ASTM A36 or ASTM A709 Grade 36
 - U-Channels and filler plates: ASTM A36 or ASTM A1011 (Grade 36).
 - Stainless steel (SS) screws: Type 316 or 18-8 Alloy
 - Galvanized Steel Fasteners: coated in accordance with Specification Section 962.
 - Hex Head Bolts: ASTM A 307
 - 7/8" diameter single bolt option, Grade 36
 - 7/16" four bolt option, Grade 55
 - Adhesive Anchors: ASTM F1554 fully threaded rods, Grade 55
 - Hex Nuts: ASTM A563
 - Flat Washers: ASTM F436
 - Plate Washers: ASTM A36 or ASTM A706 Grade 36.
 - Shims: ASTM B209 Alloy 6061
 - Bearing Pads: 1/8" Plain, Fabric Reinforced or Fabric Laminated pads that meet the requirements of Specification Section 932 for Ancillary Structures.
- Fabricate pickets and vertical panel elements parallel to the posts; except Type 2, 3 and 5 panel infills may be fabricated parallel to the longitudinal grade. Maintain a maximum clear opening of 5/8" for standard installations and 3/8" when a 4" sphere requirement is indicated in the Data Tables.
- Maximum spacing between expansion joints is 40'-0". Locate an Expansion Joint between the posts on either side of the Deck Expansion Joint.
- Field splices are similar to the Expansion Joint Detail and may be approved by the Engineer to facilitate handling; but the top rail must be continuous across a minimum of two posts.
- For intermediate and bottom horizontal rails, the screwed joints shown may be substituted with alternate joints shown in detail "K".
- Make corners and changes in tangential longitudinal alignment with a 9" bend radius or terminate adjoining sections with mitered end sections when handrails are not required.
- For changes in tangential longitudinal alignment greater than 45°, position posts a maximum of 2'-0" each side of the corner but not at the corner apex.
- For curved longitudinal alignments, shop bend the top and bottom rails and handrails to match the alignment radius.
- Handrails are required and must be continuous at landings for:
 - Grades Steeper than 5%,
 - Three or more steps
- Installation: Cutting of reinforcing steel is permitted for post installed anchors.

10/12/2020 7:29:27 AM

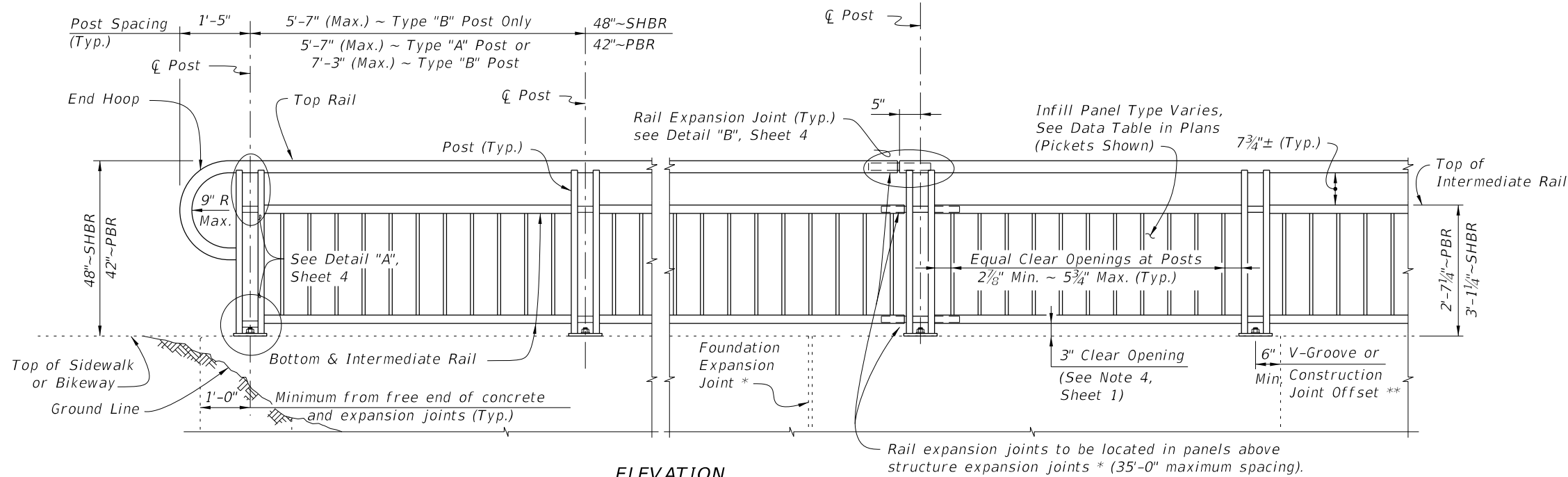

ELEVATION
(Showing Outside Face of Railing with Type "A" Posts)

TYPICAL RAILING DETAILS & RAILINGS ON GRADES 0% TO 5%
(Type 1 - Picket Railing Shown, Other Types Similar)

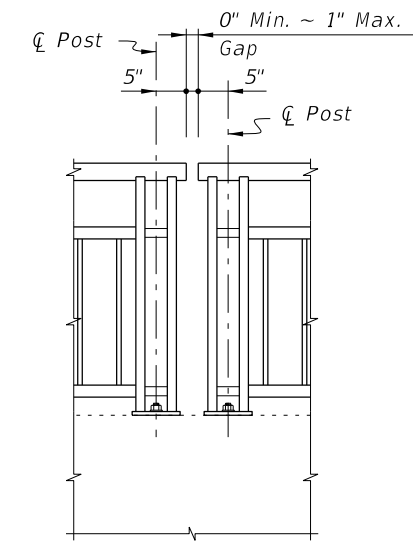

Note: Non-continuous corners are permitted when handrails are not required.

EXPANDED ELEVATION AT CORNERS
DETAIL FOR NON-CONTINUOUS RAILING AT CORNERS

- NOTES:**
 * Keyed construction joints in Index 400-011 Gravity Wall are not considered to be expansion joints.
 ** Contraction joints (Tooled or Saw Cut) in sidewalks do not require a 6" minimum offset.

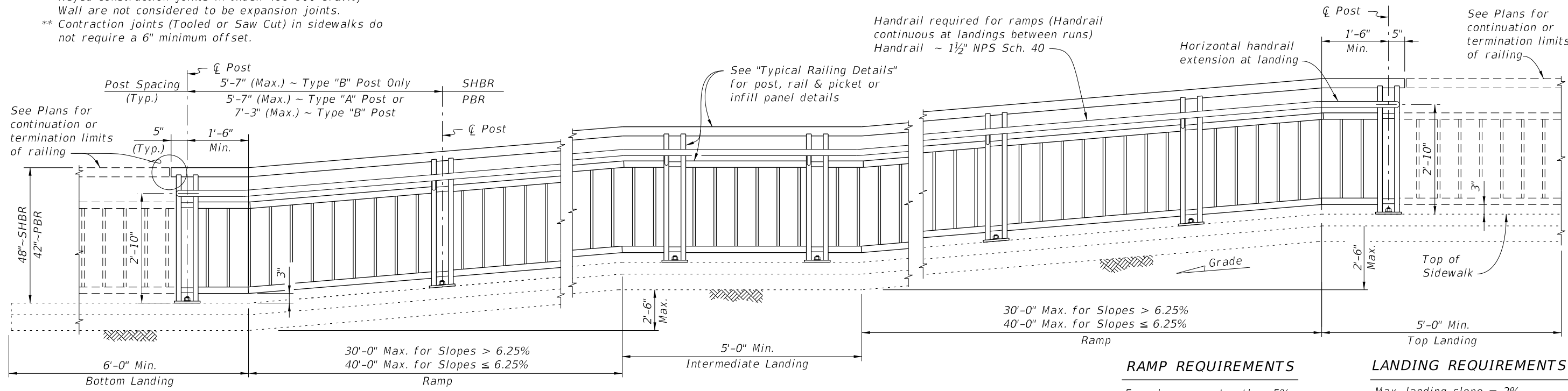

ELEVATION
(Showing Inside Face of Railing with Type "A" Posts)

RAILINGS ON GRADES STEEPER THAN 5%
(Type 1 - Picket Railing Shown, Other Types Similar)

- RAMP REQUIREMENTS**
 For slopes greater than 5%:
 Max. ramp slope = 8.33%
 Max. ramp cross-slope = 2.0%
- LANDING REQUIREMENTS**
 Max. landing slope = 2%
 Max. landing cross-slope = 2%

10/12/2020 7:29:30 AM

LAST REVISION 11/01/16	DESCRIPTION:
---------------------------	--------------



FY 2021-22
STANDARD PLANS

PEDESTRIAN/BICYCLE RAILING (STEEL)

INDEX
515-052

SHEET
2 of 8

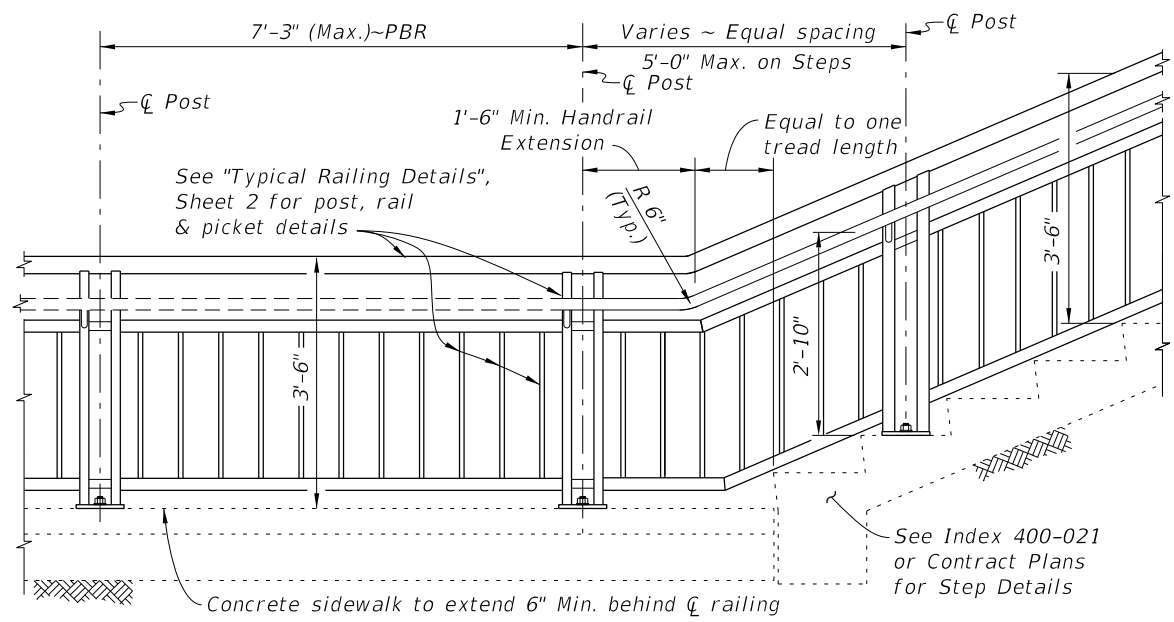

RAILING CONTINUATION BEYOND STEPS OR STAIRS
(Bottom shown, Top similar)

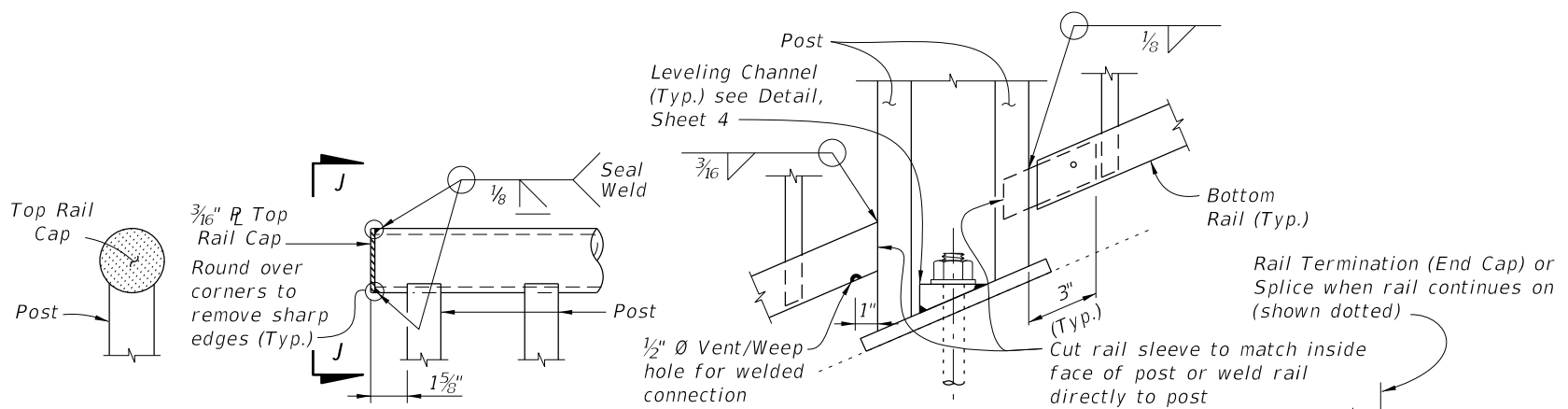

VIEW J-J DETAIL "J" - ELEVATION VIEW TOP RAIL TERMINATION

DETAIL "K" - ELEVATION VIEW BOTTOM RAIL CONNECTION (Intermediate Rail Similar)

RAIL TERMINATION DETAILS

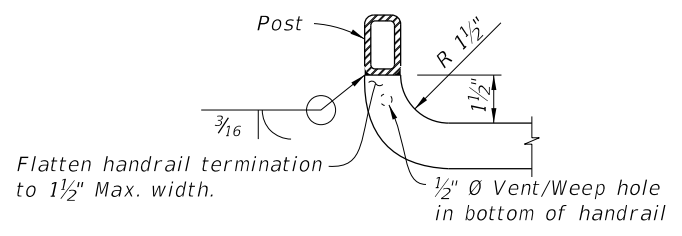

DETAIL "L" - PLAN VIEW HANDRAIL TERMINATION

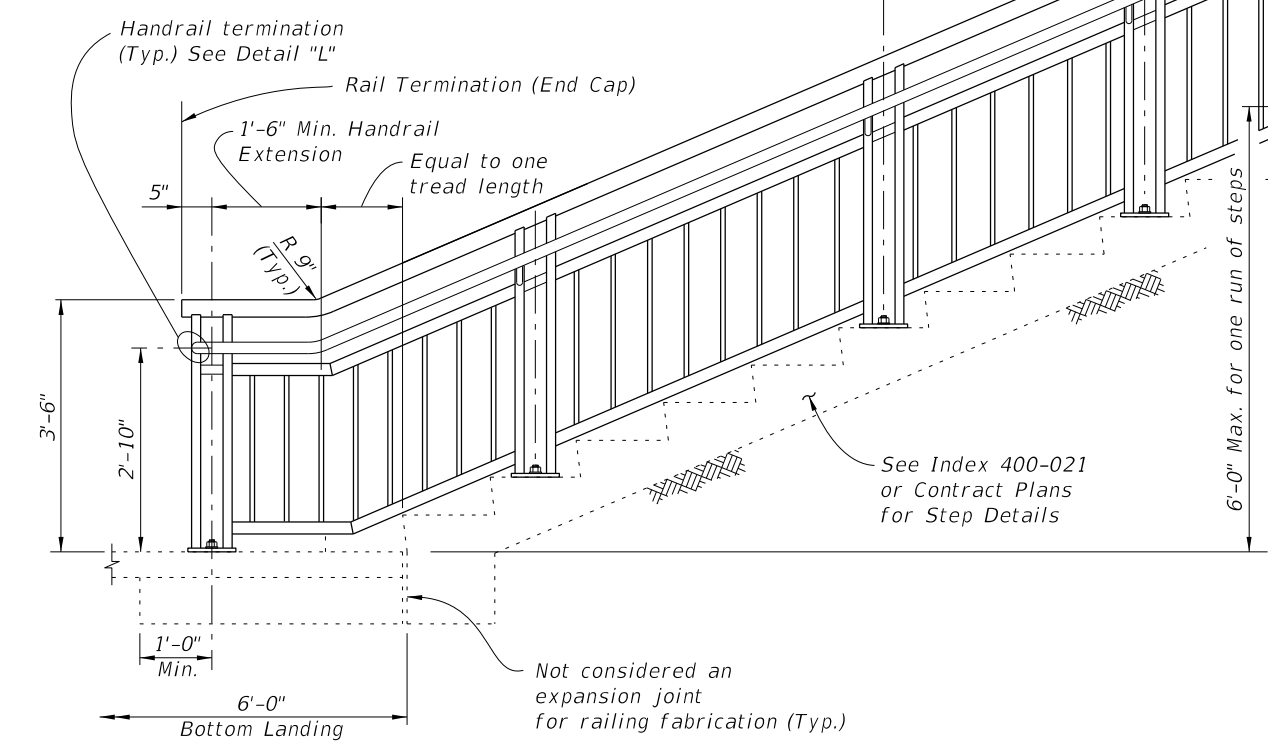

ELEVATION (At-Grade Steps shown, Elevated Stairs similar)

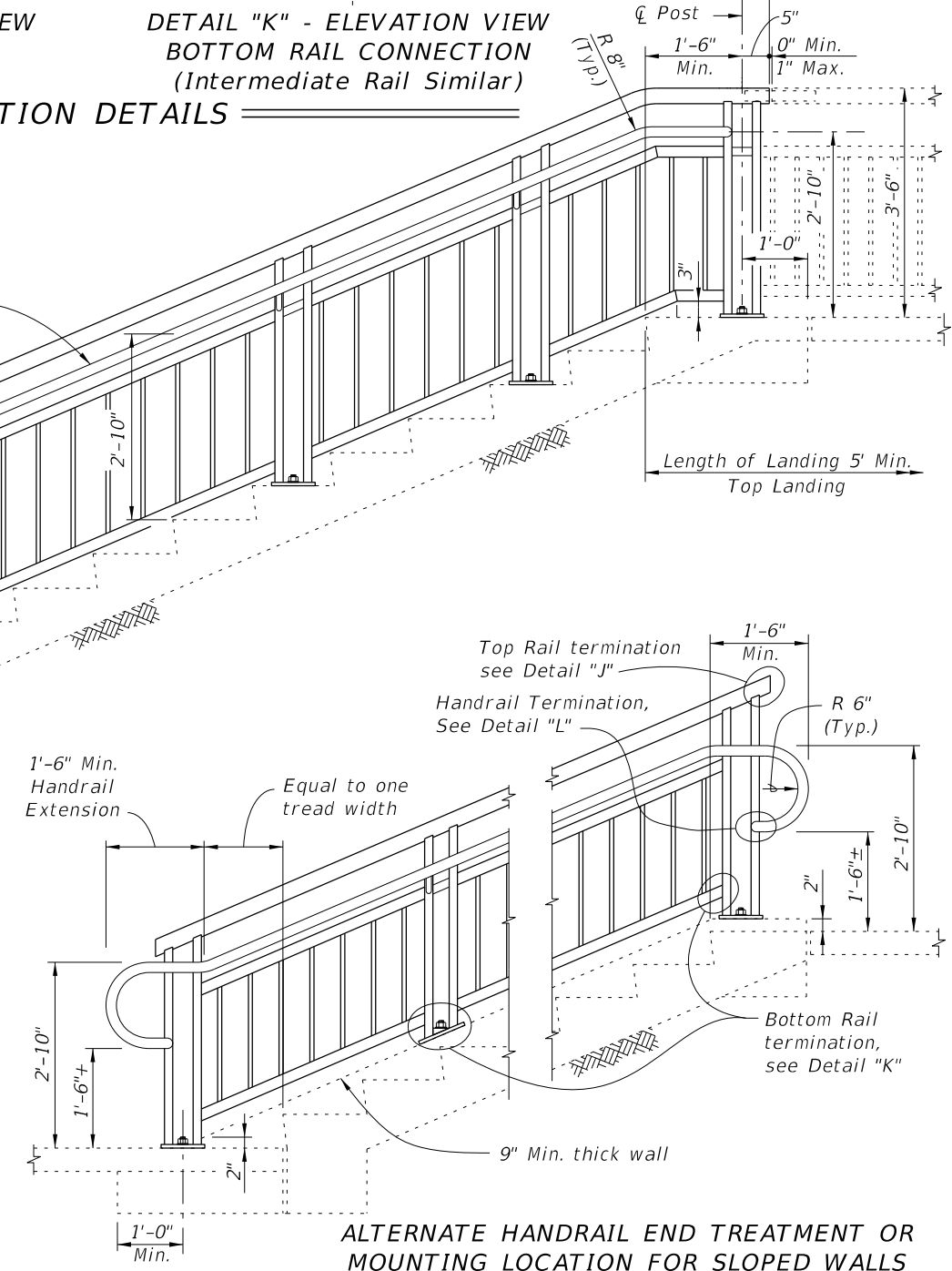

ALTERNATE HANDRAIL END TREATMENT OR MOUNTING LOCATION FOR SLOPED WALLS

10/12/2020 7:29:33 AM

LAST REVISION 11/01/16	DESCRIPTION:	 FY 2021-22 STANDARD PLANS	PEDESTRIAN/BICYCLE RAILING (STEEL)	INDEX 515-052	SHEET 3 of 8
---------------------------	--------------	--	------------------------------------	------------------	-----------------

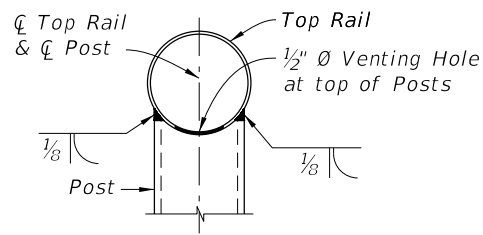

SECTION A-A
(Top Rail Connection)

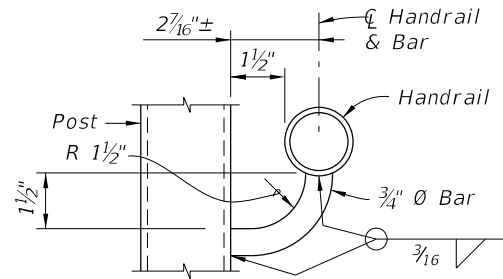

SECTION B-B
(Handrail Connection)

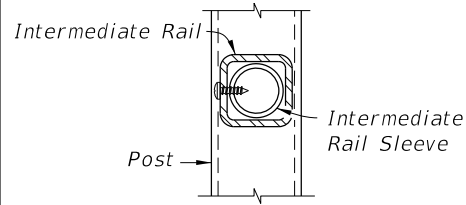

SECTION C-C
(Intermediate Rail Connection)

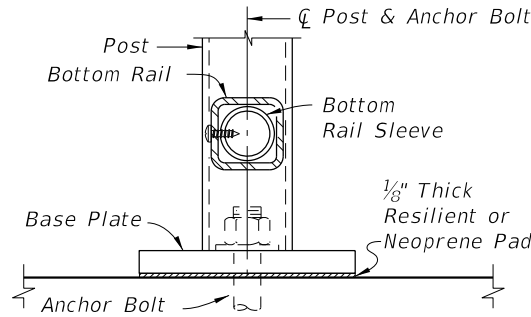

SECTION D-D
(Bottom Rail Connection -
Single Anchor Bolt Shown)

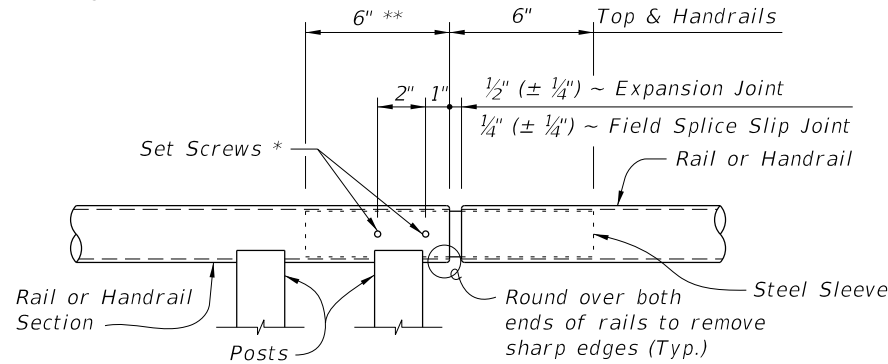

ROUND RAILS - TOP RAIL OR HANDRAIL
(Top Rail at Expansion Joint Shown)

DETAIL "B" - EXPANSION JOINT (FIELD SPLICE SLIP JOINT SIMILAR)

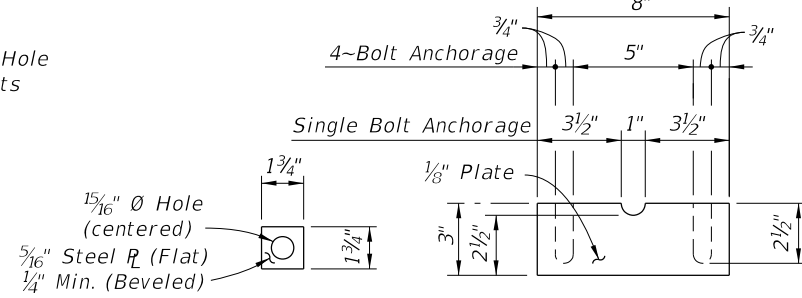

SHIM PLATE DETAIL

PLATE WASHER DETAIL

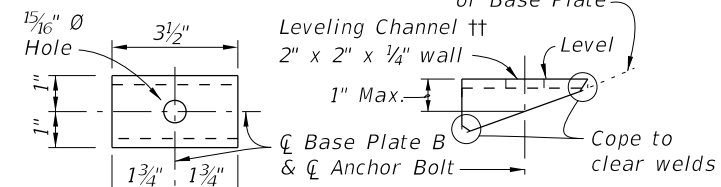

TOP VIEW

SIDE VIEW

LEVELING CHANNEL DETAIL

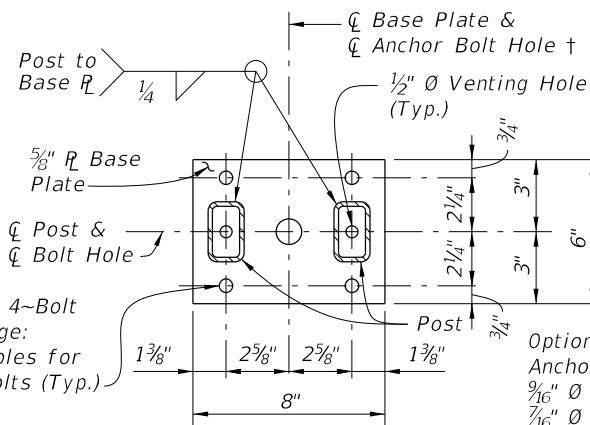

BASE PLATE A

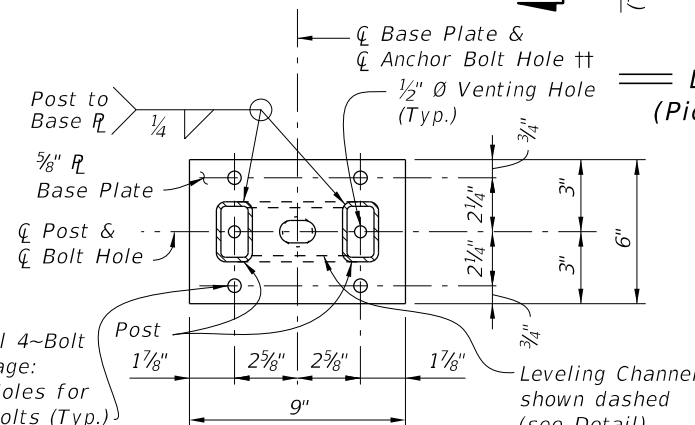

BASE PLATE B

SECTION G-G - BASE PLATE DETAILS

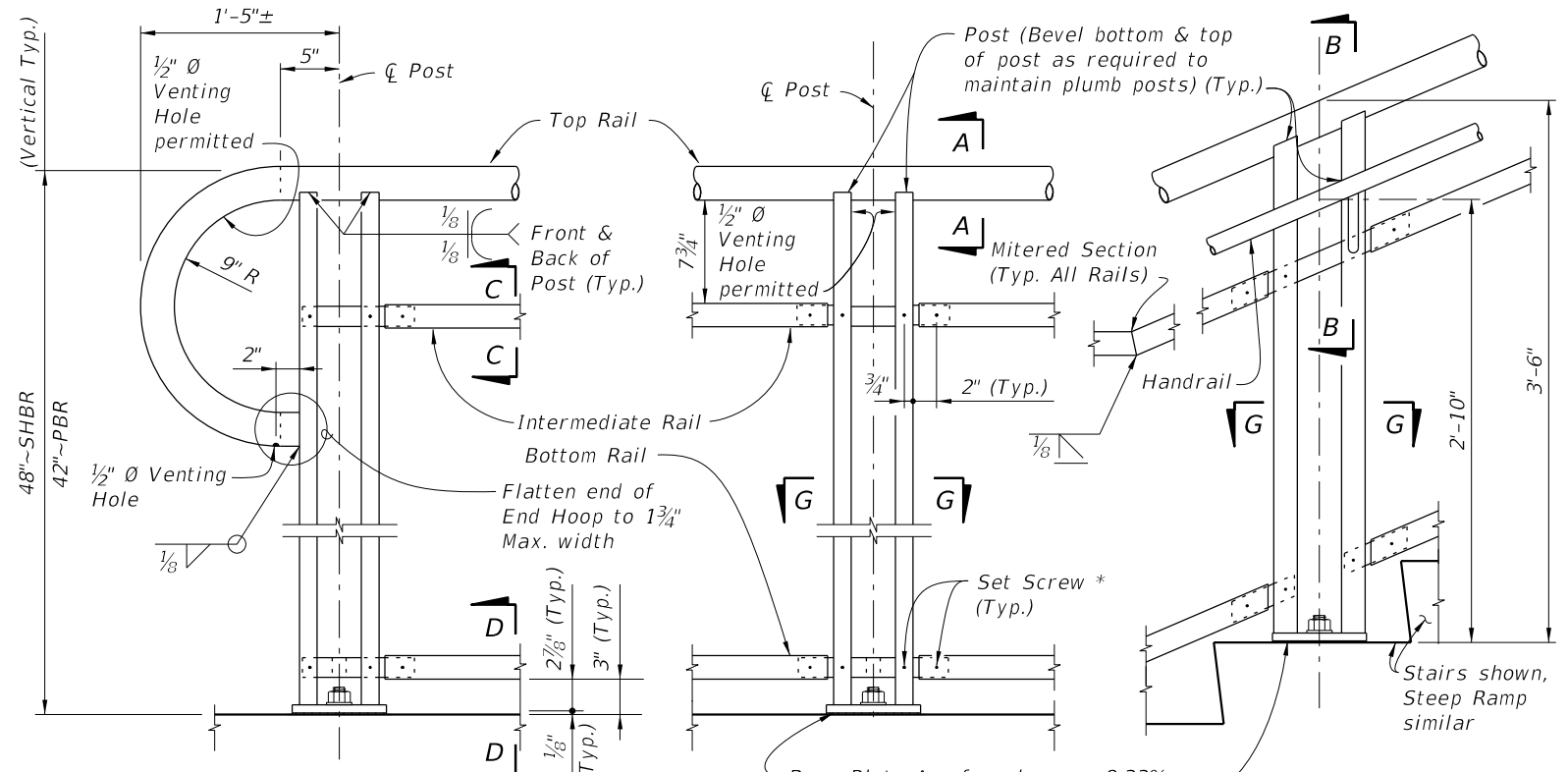

DETAIL "A" - RAIL CONNECTIONS
(Pickets/Panels and 4-Bolt Anchorage
Not Shown for Clarity)

NOTES:

- † Base Plate A (Ramps - Bolts normal) use 1 1/16 inch diameter holes for single anchor bolts with flat washers for slopes less than or equal to 8.33%.
- ‡ Base Plate B (Stairs - Bolts plumb) use 1 1/4 inch diameter holes for single anchor bolts with beveled plate and washers for slopes greater than 8.33% to less than or equal to 15%; use 1 5/16 inch x 1 1/2 inch slotted holes with leveling channel for slopes greater than 15%.
- * 1/4 inch x 3/4 inch Pan Head Stainless Steel (Type 316 or 18-8 Alloy) Set Screws. Screws must be set flush against the outside face of rails & posts and underside of handrails. 1/2 inch diameter plug welds may be substituted for the set screws. Do not provide set screws for rails at free end of expansion joints.
- ** Embedded length may be 4 inches for plug welded connection.

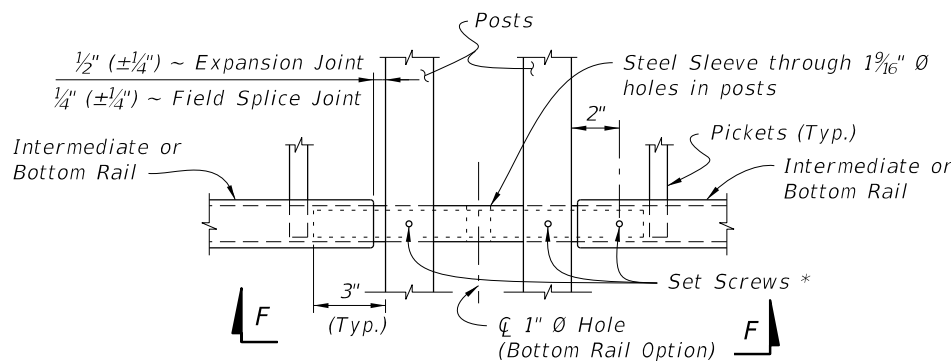

SQUARE RAILS - INTERMEDIATE OR BOTTOM RAIL
(Bottom Rail at Expansion Joint Shown)

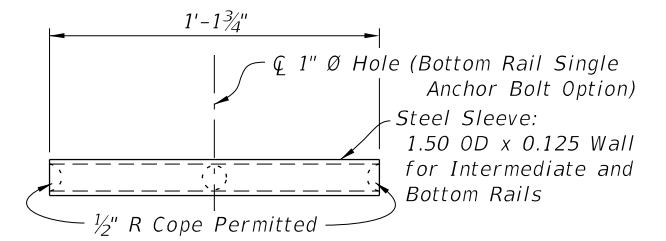

VIEW F-F
INTERMEDIATE OR BOTTOM RAIL -
STEEL SLEEVE DETAIL (Bottom Side Shown)

CROSS REFERENCE:
For location of Details "B", See Sheet 2.

10/12/2020 7:29:36 AM

LAST REVISION	DESCRIPTION:
11/01/16	

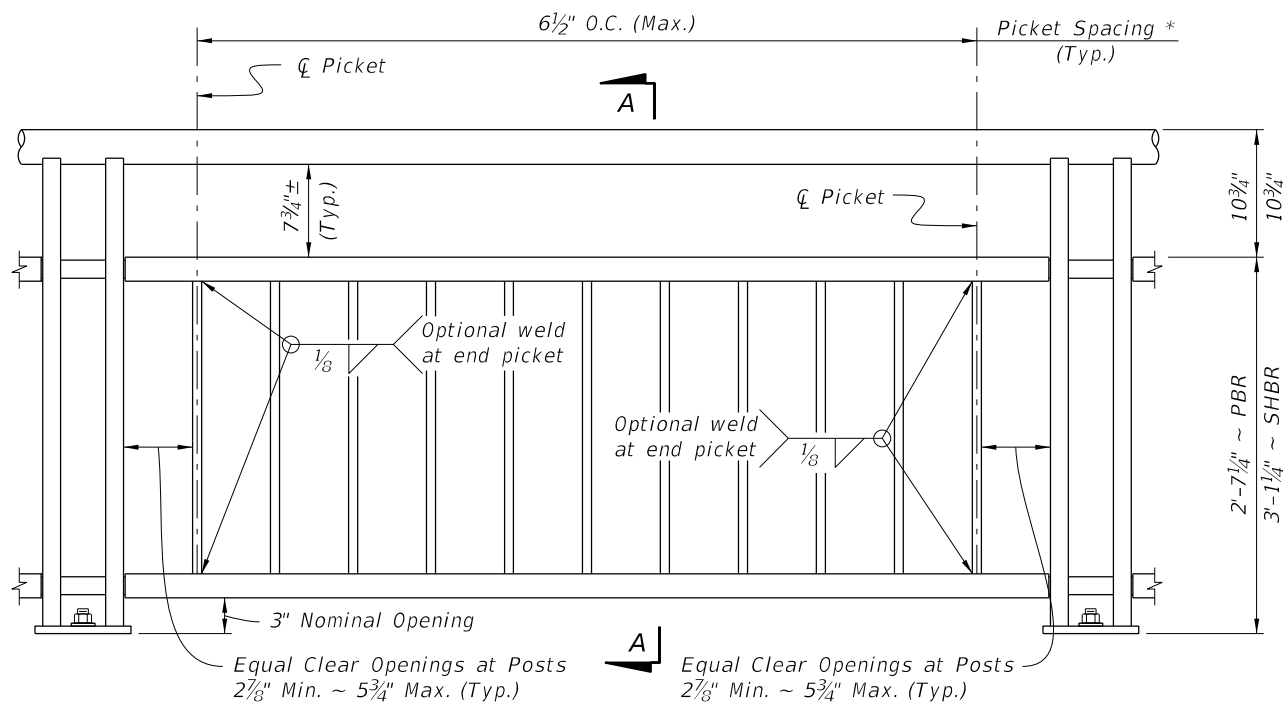

SECTION A-A

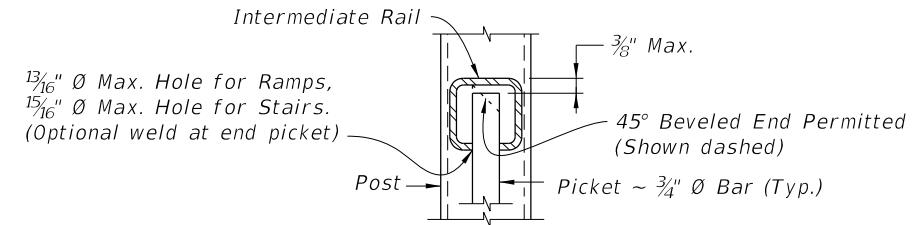

DETAIL "1A"
(Top of Picket Connection)

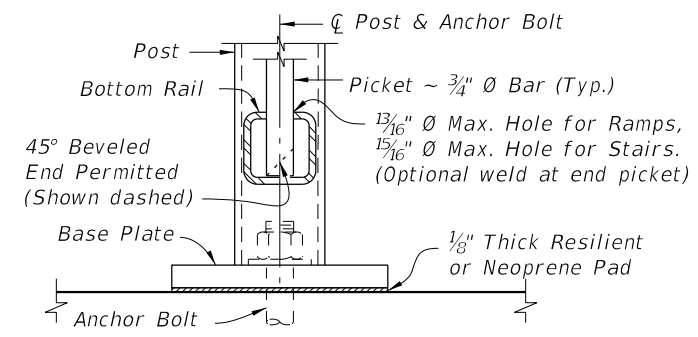

DETAIL "1B"
(Bottom of Picket Connection)

TYPE 1 - PICKET INFILL PANEL

PICKET NOTES:
 * Picket Spacing of 6 1/2" centers is based on a 3/4" Ø Bar for standard applications.
 When shown in the Contract Plans a 4 1/2" picket spacing may be required. See Note 4 (Sheet 1).

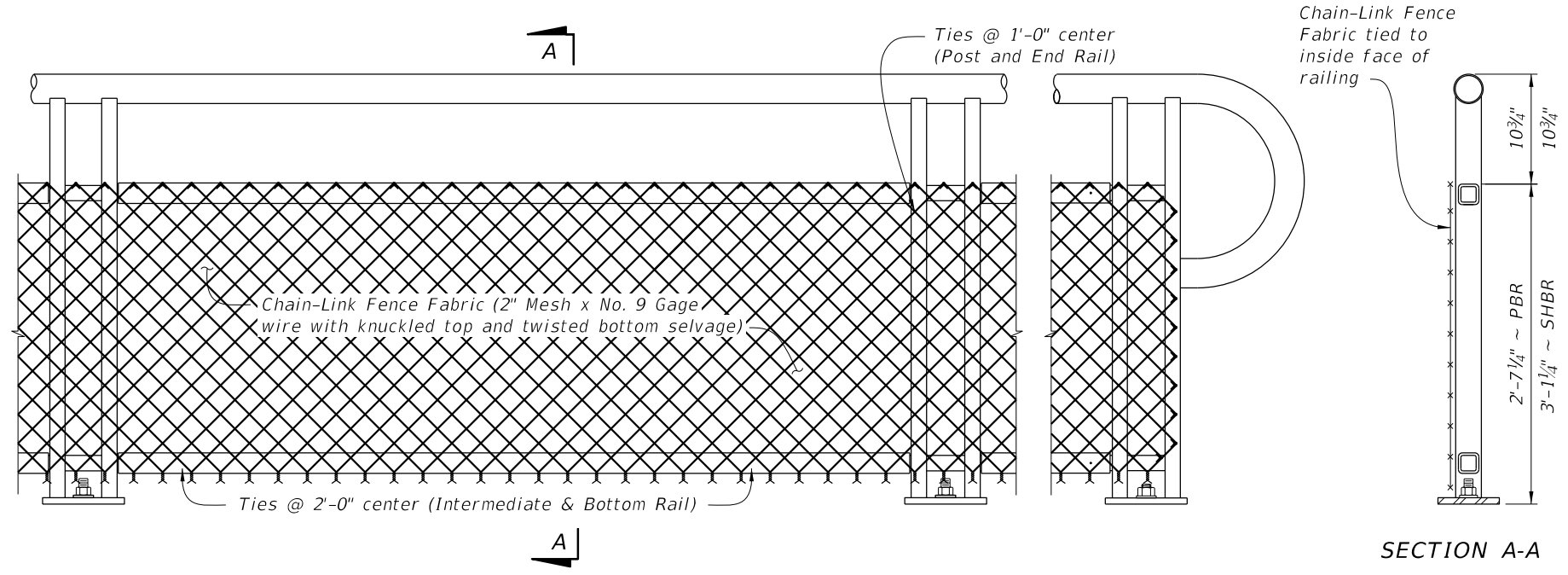

SECTION A-A

TYPE 2 - CHAIN-LINK (Continuous Infill Panel)

NOTES:
 1. See Plans for Infill Panel option required.

TABLE 2 - CHAIN-LINK PANEL COMPONENT MATERIALS		
COMPONENT	ASTM	COMPONENT INFORMATION
Chain-Link Fence Fabric (2" mesh with twisted bottom and knuckled top selvage)	A 392	Zinc-Coated Steel - No. 9 gage (coated wire diameter), Class 2 Coating
	A 491	Aluminum-Coated Steel - No. 9 gage (coated wire diameter)
	F 668	Polyvinyl Chloride (PVC) Coated Steel - No. 9 gage Zinc-Coated Wire (metallic-coated core wire diameter) ~ See Plans for specified color of PVC.
Tie Wires	F 626	Zinc-Coated Steel Wire - No. 9 gage with coating to match Chain-Link Fence Fabric.
Tension Bars	F 626	3/16" (Min. thickness) x 3/4" (Min. width) x 2'-3' (Min. height) Steel Bars
Miscellaneous Fence Components	F 626	Zinc-Coated Steel

CHAIN-LINK PANEL NOTE:
 Chain-Link Fence Fabric shall be continuous along limits of railing.
 Splicing of Chain-Link panels using Tension Bars at 20'-0" minimum increments is permitted.

10/12/2020 7:29:39 AM

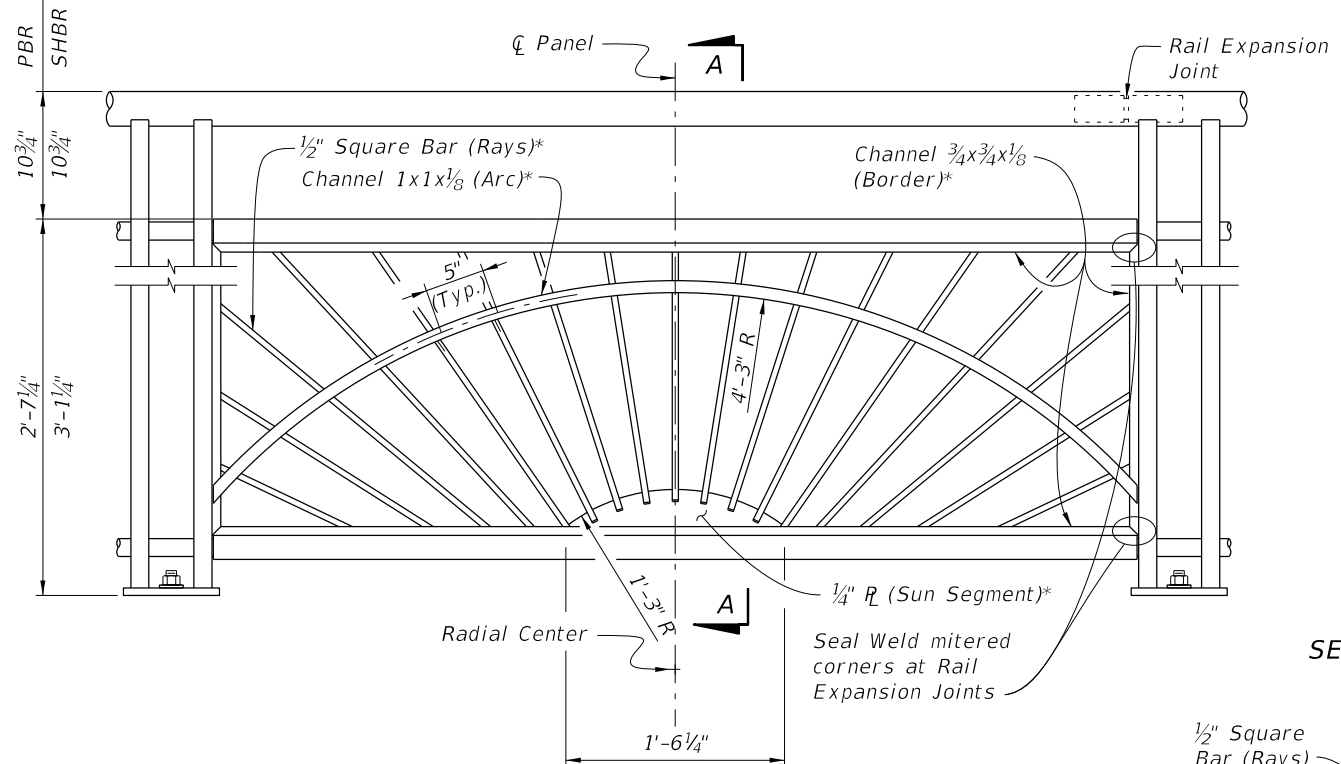

TYPE 3 - SUNSHINE INFILL PANEL

* Arc, Rays and Sun Segment may be formed in a single panel from 1/2" steel plate pattern cut with laser or plasma CNC, welded to a 1x1 1/8" Angle Border or the 3/4x3/4x1/8" Channel Border shown.

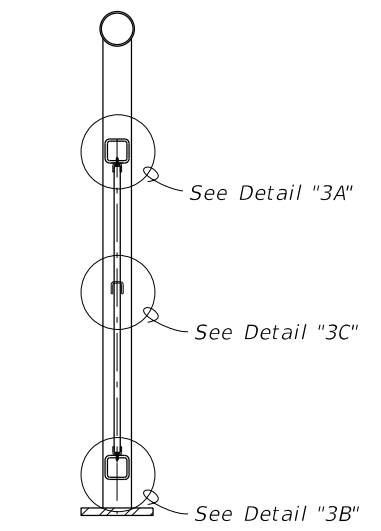

SECTION A-A

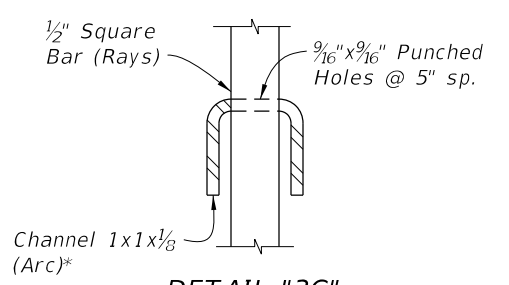

DETAIL "3C" RAY/ARC CONNECTION

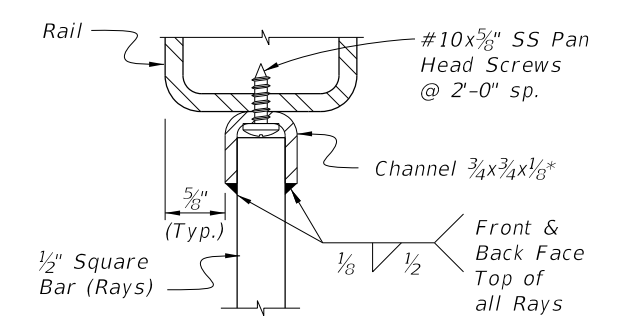

DETAIL "3A" INTERMEDIATE RAIL/RAY CONNECTION

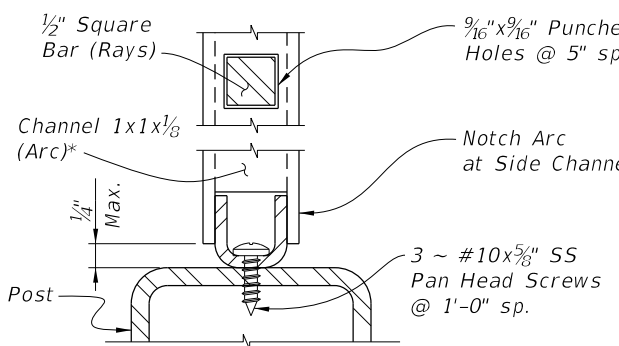

DETAIL "3D" ARC/POST CONNECTION (Continuous Top Rail)

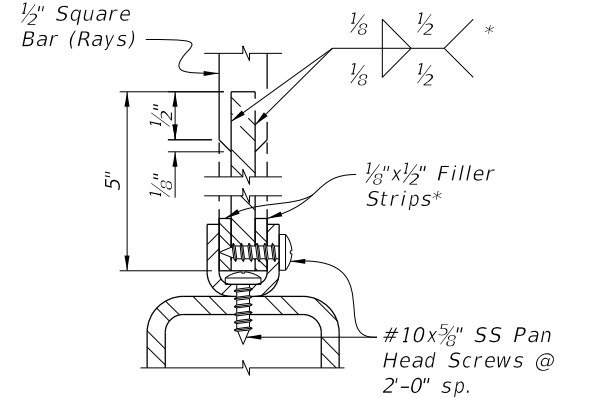

DETAIL "3B" BOTTOM RAIL/RAY CONNECTION

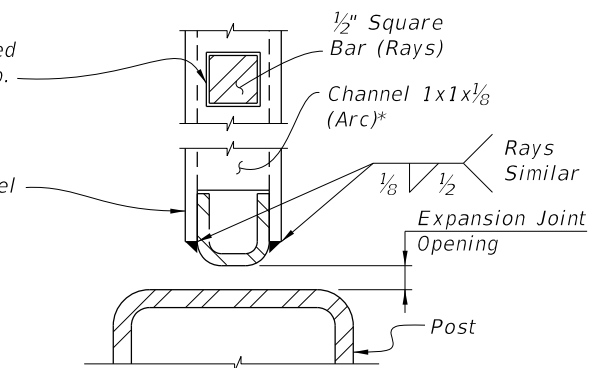

DETAIL "3E" PANEL END CONNECTION AT POST WITH EXPANSION JOINT

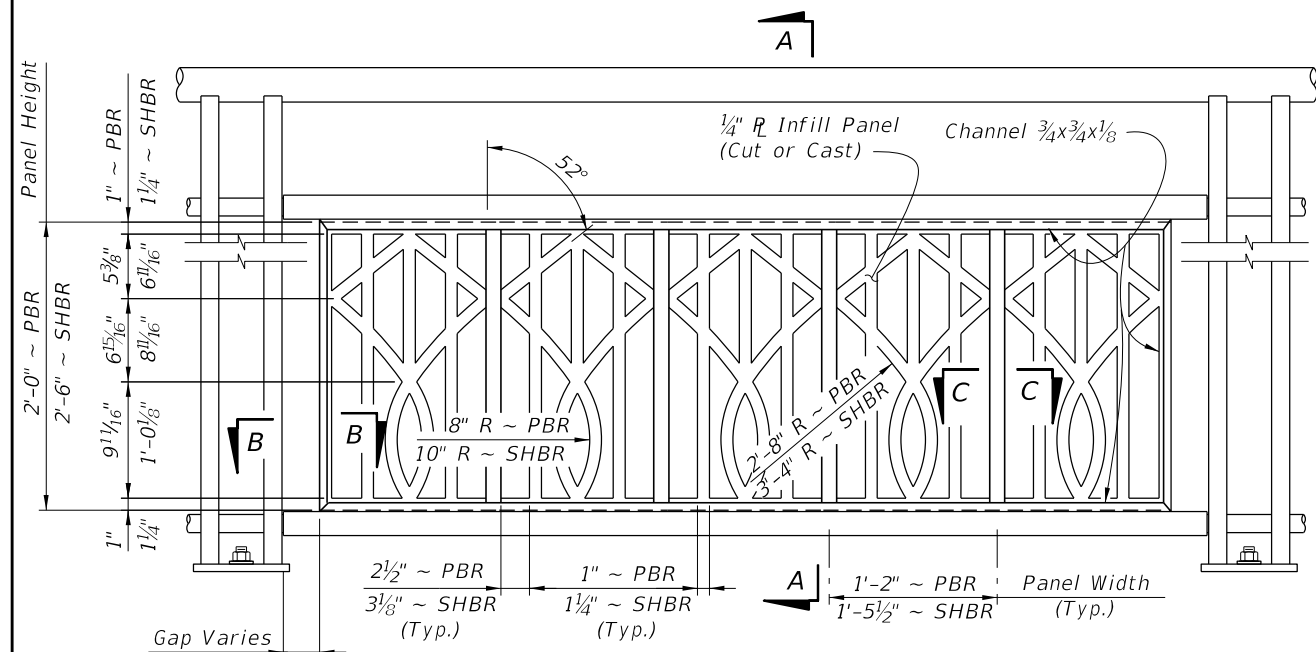

TYPE 4 - BROADWAY INFILL PANEL

NOTES:
1. See Plans for Infill Panel Option required.

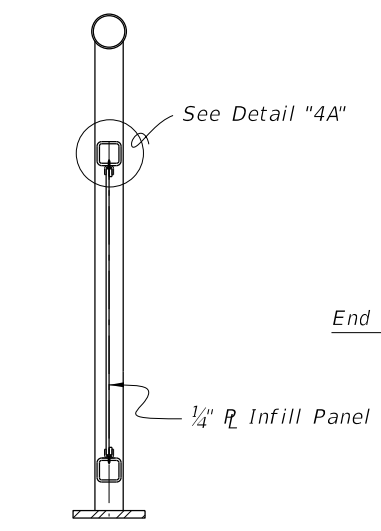

SECTION A-A

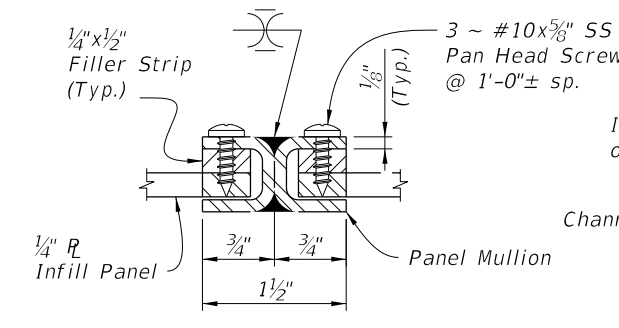

SECTION C-C PANEL/SPLICE CONNECTION

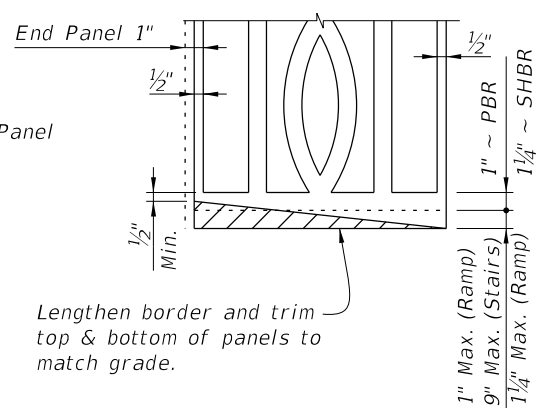

PANEL ADJUSTMENT FOR RAILINGS ON GRADES

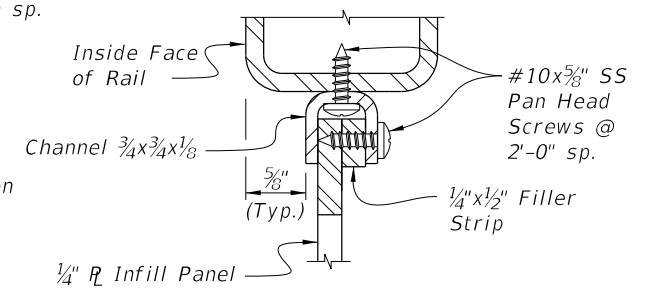

DETAIL "4A" PANEL/RAIL CONNECTION (Top Shown, Bottom Similar)

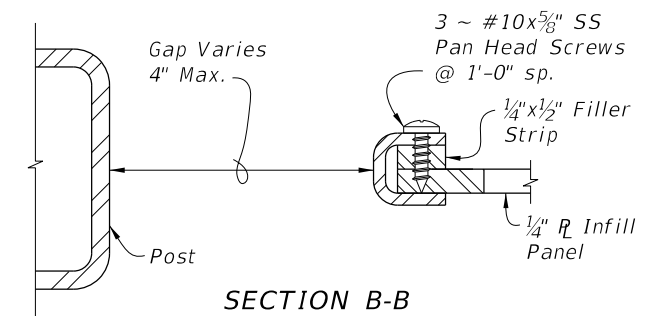

SECTION B-B PANEL END CAP

10/12/2020 7:29:41 AM

LAST REVISION 11/01/16	DESCRIPTION:	FDOT FY 2021-22 STANDARD PLANS	PEDESTRIAN/BICYCLE RAILING (STEEL)	INDEX 515-052	SHEET 6 of 8
---------------------------	--------------	--------------------------------------	------------------------------------	------------------	-----------------

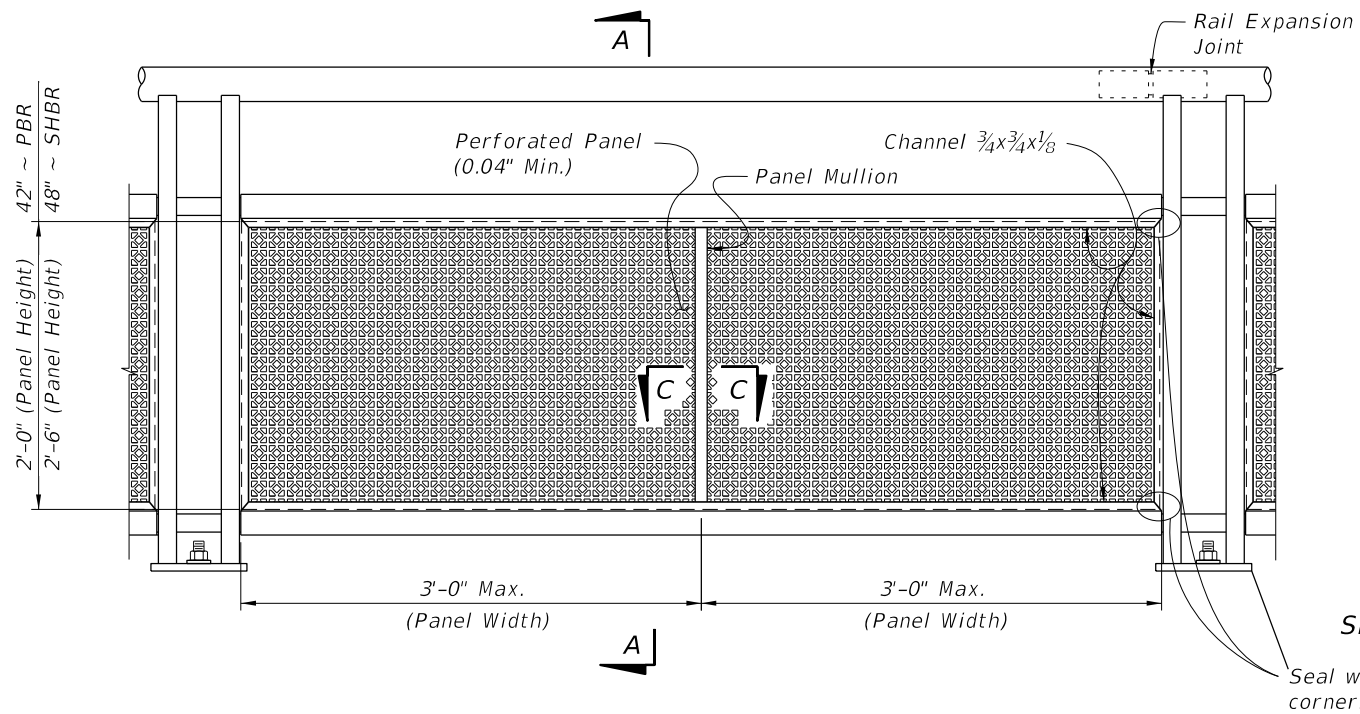

TYPE 5 - PERFORATED INFILL PANEL

SECTION A-A

Seal welding mitered corners is permitted

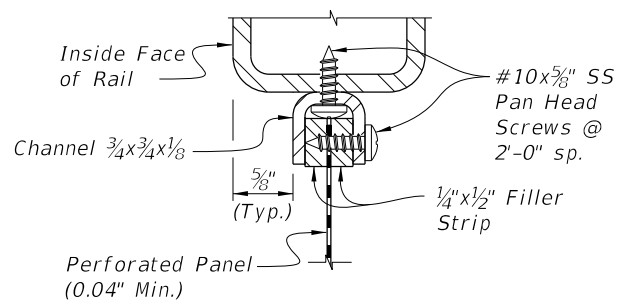

DETAIL "5A"
PANEL/RAIL CONNECTION
 (Top Shown, Bottom Similar)

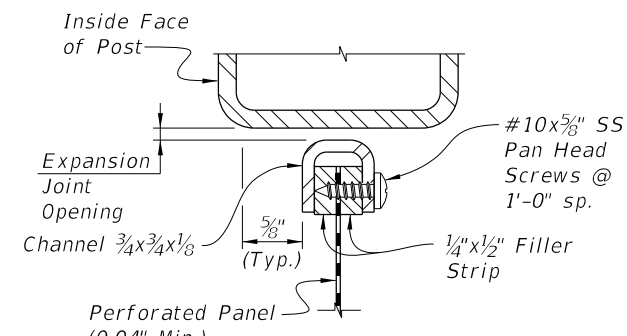

DETAIL "5B"
PANEL END CONNECTION
 (Expansion Joint Shown, Sides Similar)

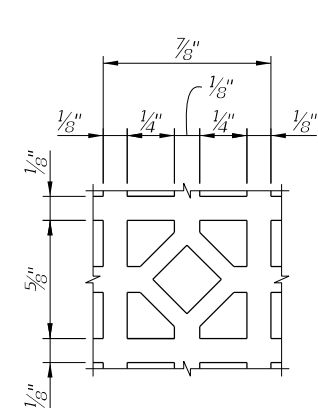

REPEATING PATTERN DETAIL
FOR PERFORATED PANEL

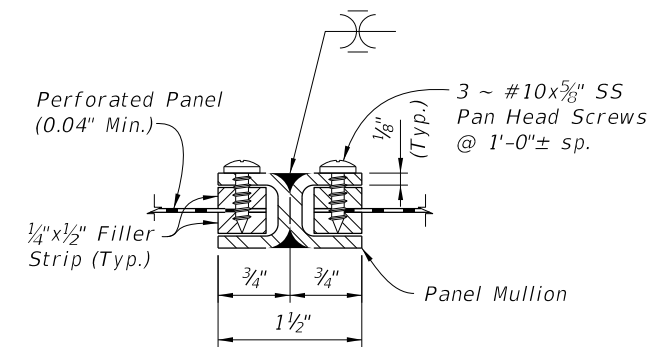

SECTION C-C
PANEL/SPLICE CONNECTION

NOTES:

- 1. See Plans for Infill Panel Type required.

10/12/2020 7:29:46 AM

LAST REVISION 11/01/16	REVISION	DESCRIPTION:	 FY 2021-22 STANDARD PLANS	PEDESTRIAN/BICYCLE RAILING (STEEL)	INDEX 515-052	SHEET 7 of 8
---------------------------	----------	--------------	---	---	-------------------------	------------------------

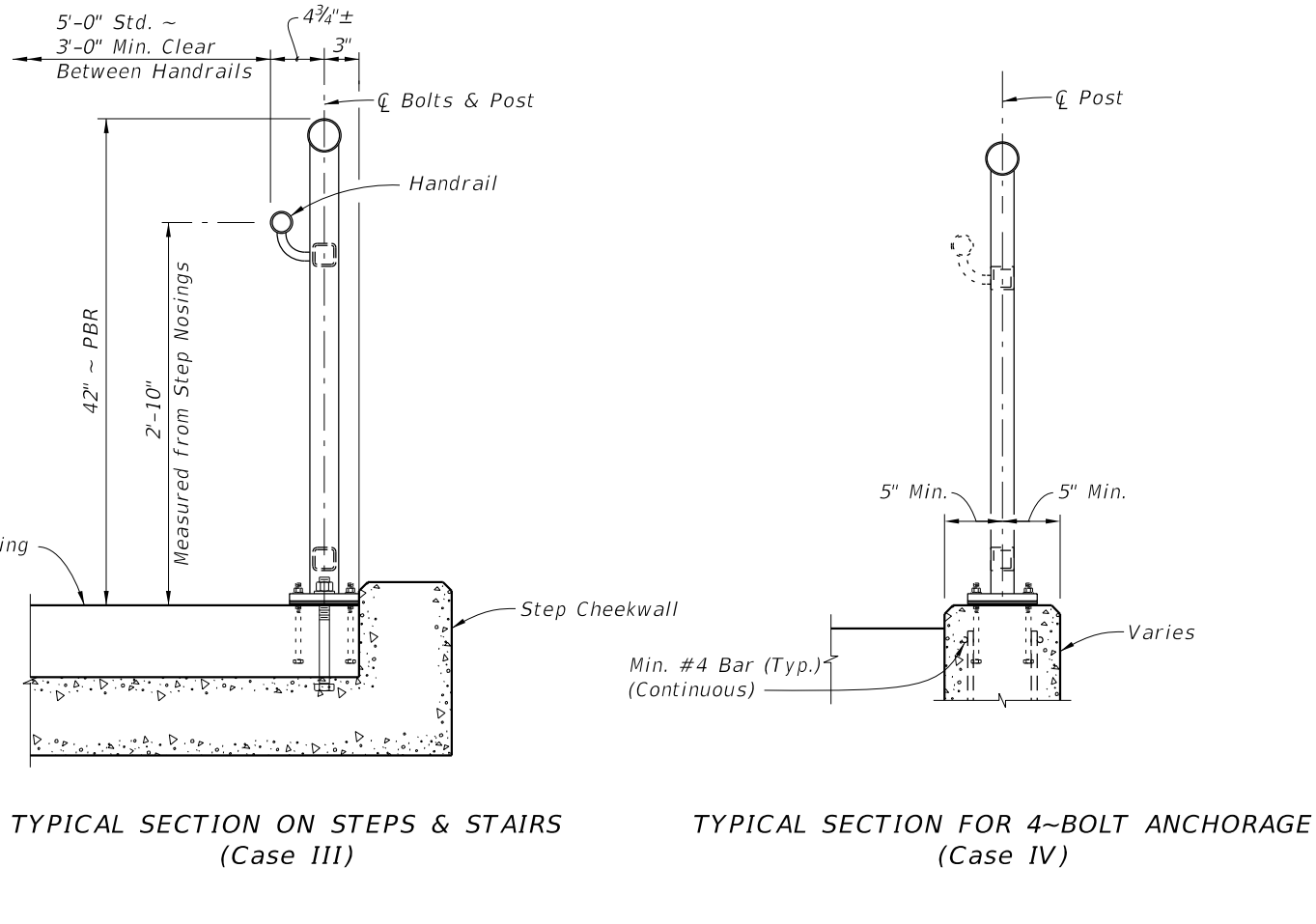
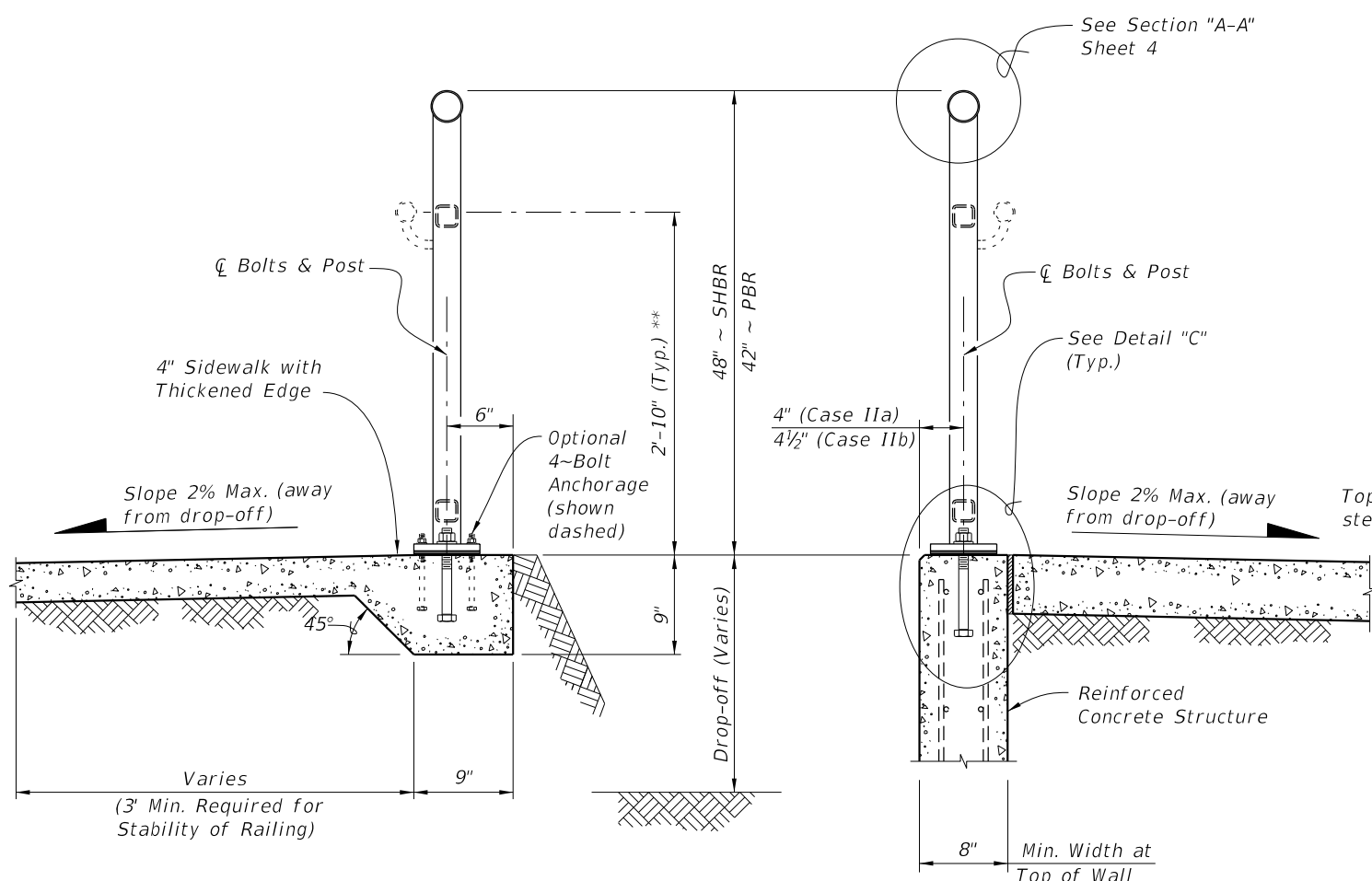

TYPICAL SECTION ON CONCRETE SIDEWALK (Case I)

TYPICAL SECTION ON RETAINING WALL (Case II)

TYPICAL SECTION ON STEPS & STAIRS (Case III)

TYPICAL SECTION FOR 4-BOLT ANCHORAGE (Case IV)

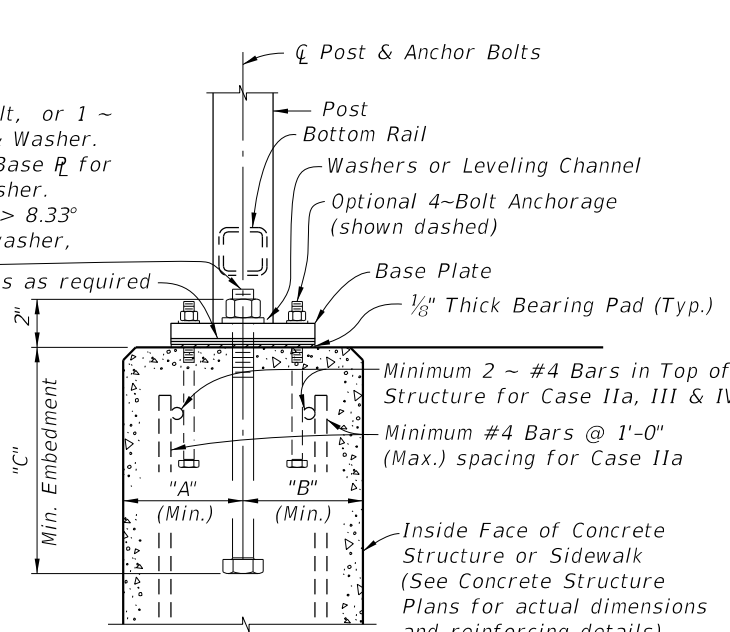
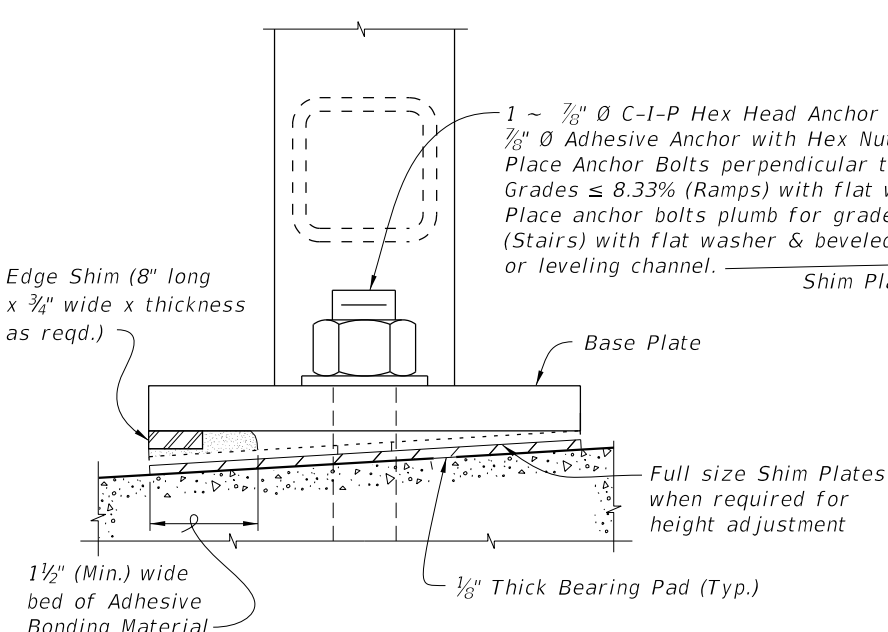

ANCHOR BOLT TABLE							
CASE	STRUCTURE TYPE	DIMENSIONS			ANCHOR LENGTH		ANCHOR SIZE
		A Edge Dist.	B Edge Dist.	C Embedment	C-I-P Hex Head Bolt	Adhesive Anchor	
I	Unreinforced Concrete	6"	1'-2"	6"	7 1/2"	8"	7/8" Ø
IIa	Reinforced Concrete	4"	4"	9"	10 1/2"	11"	7/8" Ø
IIb	Gravity Wall Index 400-011	4 1/2"	3 1/2" @ top	9"	10 1/2"	11"	7/8" Ø
III	Step Cheekwall	4 1/2"	4 1/2"	9"	10 1/2"	11"	7/8" Ø
IV	Varies	5"	5"	5"	6 1/2"	7"	7/16" Ø

** When required; measured from top of sidewalk.

10/12/2020 7:29:50 AM