

ELEVATION

**ALTERNATE STRAND PATTERNS**

- 4 ~ 0.6" Ø, CFRP 7-Strand, at 42 kips
- 4 ~ 1/2" Ø, CFRP Single-Strand, at 41 kips

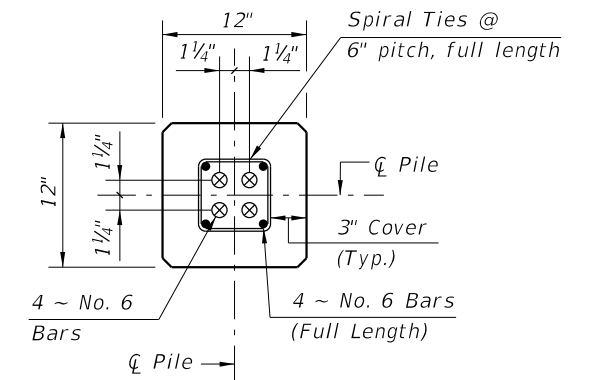
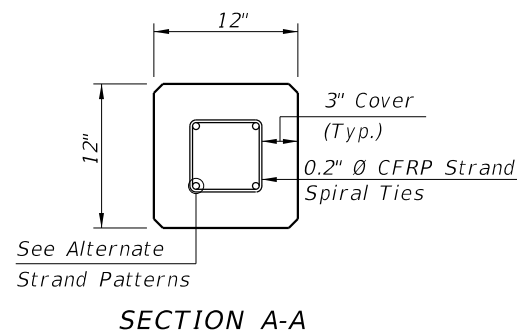

**SECTION D-D**  
(See Non-Drivable Unforeseen Reinforced Precast Pile Build-Up Detail)

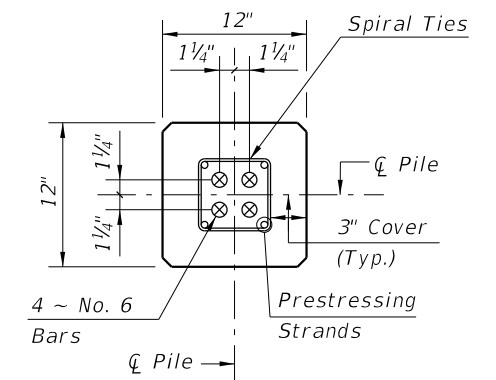

**SECTION E-E**  
(See Drivable Unforeseen Prestressed Precast Pile Splice Detail)

**CFRP PILE SPLICE REINFORCEMENT DETAILS**

- NOTES:
1. Work this Index with Index 455-101 - Typical Details and Notes for Square CFRP & SS Prestressed Concrete Piles and Index 455-102 - Square CFRP & SS Prestressed Concrete Pile Splices.
  2. Any of the given Alternate Strand Patterns may be utilized.

**CFRP PRESTRESSED PILE DETAILS**

10/8/2020 10:26:19 AM

LAST REVISION 11/01/16	REVISION	DESCRIPTION:		FY 2021-22 STANDARD PLANS	12" SQUARE CFRP & SS PRESTRESSED CONCRETE PILE	INDEX 455-112	SHEET 1 of 2
---------------------------	----------	--------------	--	------------------------------	---	------------------	-----------------

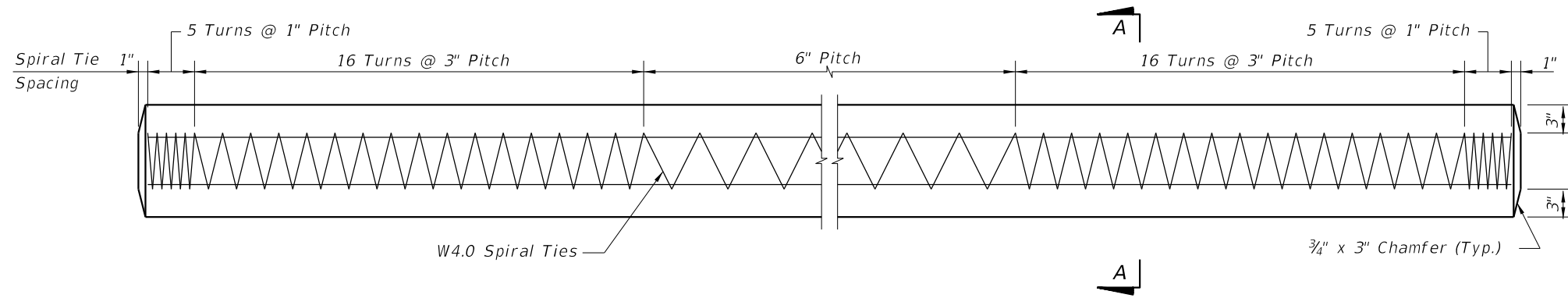

ELEVATION

**STRAND PATTERN**

8 ~ 1/2" Ø, HSSS at 24 kips  
 8 ~ 0.6" Ø, HSSS at 26 kips

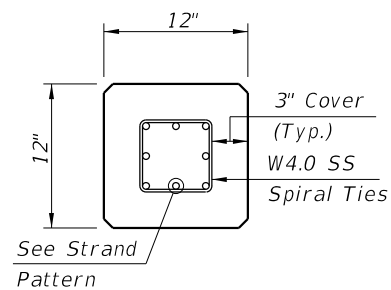

SECTION A-A

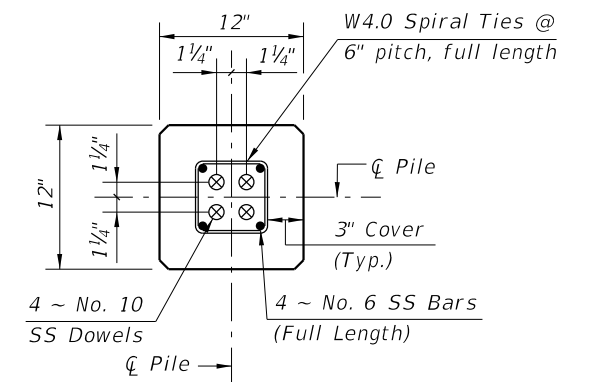

SECTION D-D

(See Non-Drivable Unforeseen Reinforced Precast Pile Build-Up Detail)

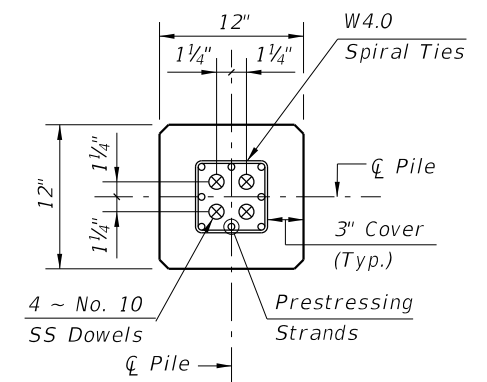

SECTION E-E

(See Drivable Unforeseen Prestressed Precast Pile Splice Detail)

**SS PILE SPLICE REINFORCEMENT DETAILS**

**NOTES:**

1. Work this Index with Index 455-101 - Typical Details and Notes for Square CFRP & SS Prestressed Concrete Piles and Index 455-102 - Square CFRP & SS Prestressed Concrete Pile Splices.
2. Any of the given Strand Patterns may be utilized.  
 The strands shall be located as follows:  
 Place one strand at each corner and place the remaining strands equally spaced between the corner strands.  
 The total strand pattern shall be concentric with the nominal concrete section of the pile.

**SS PRESTRESSED PILE DETAILS**

10/8/2020 10:26:21 AM

LAST REVISION 11/01/20	REVISION	DESCRIPTION:		FY 2021-22 STANDARD PLANS	12" SQUARE CFRP & SS PRESTRESSED CONCRETE PILE	INDEX 455-112	SHEET 2 of 2
---------------------------	----------	--------------	--	------------------------------	---	------------------	-----------------