

CASE 1

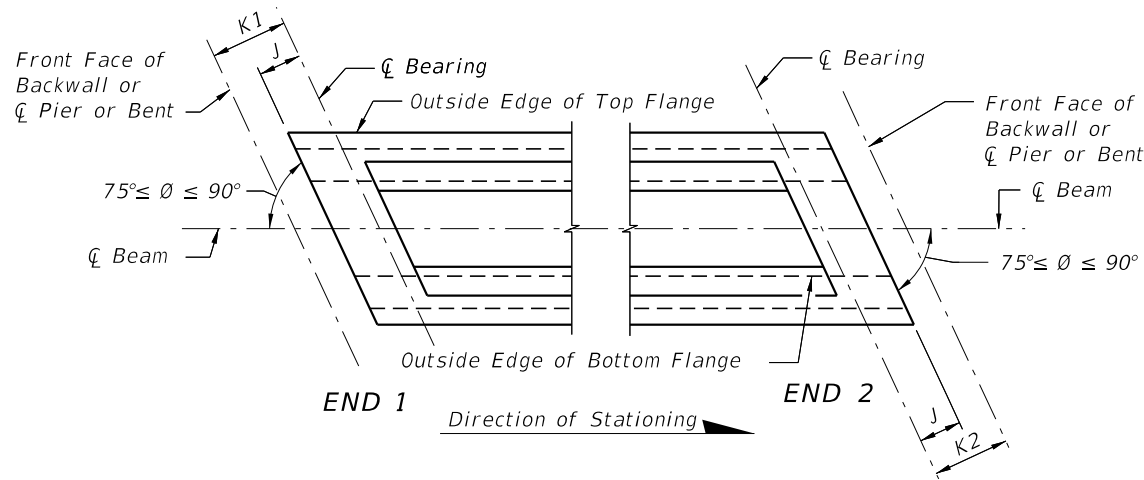

CASE 2

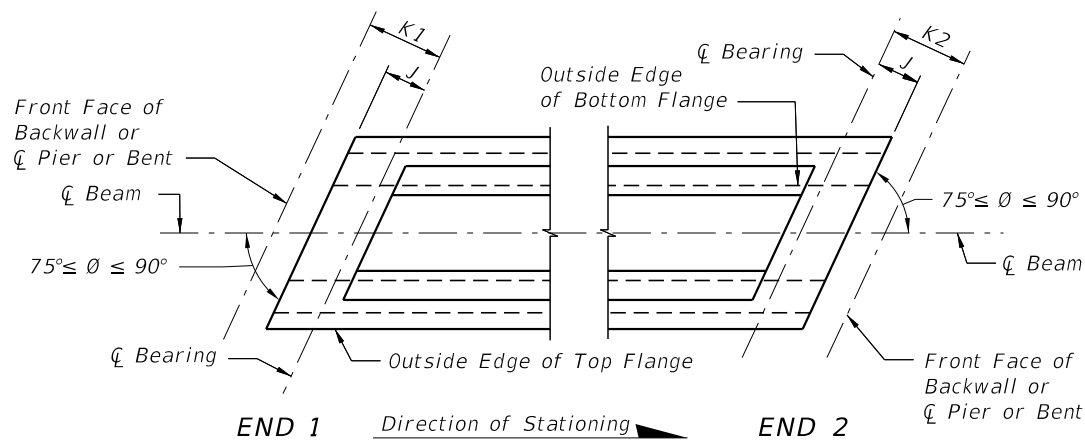

CASE 3

SCHEMATIC PLAN VIEWS AT BEAM ENDS

BEAM NOTES

1. Work this Index with the Florida-U Beam Standard Details (Index 450-248, 450-254, 450-263 and 450-272) and the Table of Beam Variables in Structures Plans.
2. All bar bend dimensions are out-to-out.
3. Concrete cover: 2 inches minimum. Maximum aggregate size is a No. 67.
4. Concrete face may be sloped with a maximum 1:24 draft to facilitate formwork removal.
5. Strands N: 3/8" Ø minimum, stressed to 10,000 lbs. each.
6. Tie Bars 5K to the fully bonded strands in the bottom row (see "STRAND PATTERN" on the Table of Beam Variables sheet in Structures Plans).
7. For beams without skewed ends or vertically beveled end conditions (see Note 8) the Engineer may approve the use of deformed WWR in lieu of Bars 6A1, 4A2, 5B, 4C, 3D, 5E, 4F, 4G, 4H, 5K, 5L and 4M. The spacing and sizes of deformed WWR must match the reinforcing sizes shown on the Florida-U Beam Standard Details sheets.
8. For Beams with vertically beveled end conditions, where "Dim. P" exceeds 1", place Bars 5E, and the first Bars 4F and 5K parallel to the end of the beam. Fan the remaining Bars 4F and 5K within the limits of "Dim. B" (End Diaphragm) at equal spaces until vertical.
9. Embedment of Safety Line Anchorage Devices are permitted in the top flange to accommodate fall protection systems. See shop drawings for details and spacing of any anchorage devices or other required embedded hardware.
10. Intermediate diaphragms must be cast and concrete release strength obtained prior to removing the beam from casting bed.
11. Place drains pipes adjacent to each web at each beam end (four drains per beam).
 - A. Drain Pipe: 2" NPS Schedule 80 PVC.
 - B. Cover, wrap and secure wire screen around the end of the pipe prior to casting. Extend screen a minimum of 1" down the pipe sides.
 - C. Provide removable pipe plugs during casting. Remove plugs from the inside of pipes after casting.
12. Protection of Strands:
 - A. Provide a 2" deep recess around all strands (including dormant) or strand groups. Extend the recessed blackout to the web face and bottom of the flange for the bottom row of strands.
 - B. After detensioning, cut strands 1/2" from recessed surface and fill the blackout to protect strands with Type F-2 or Q Epoxy Compound in accordance with Specification Section 926.
13. Use Stay-In-Place metal deck forms inside the beams.
14. Prior to deck placement, provide temporary blocking under each web at both ends of every beam. Ensure the temporary blocking is adequate to resist movements and rotations during deck placement. Leave temporary blocking and bracing in place for a minimum of four days after the deck is placed.
15. Based on the deck forming system and deck placement sequence, evaluate and provide any required temporary bracing between the U Beams.

10/8/2020 10:36:30 AM

LAST REVISION	11/01/16	DESCRIPTION:
---------------	----------	--------------

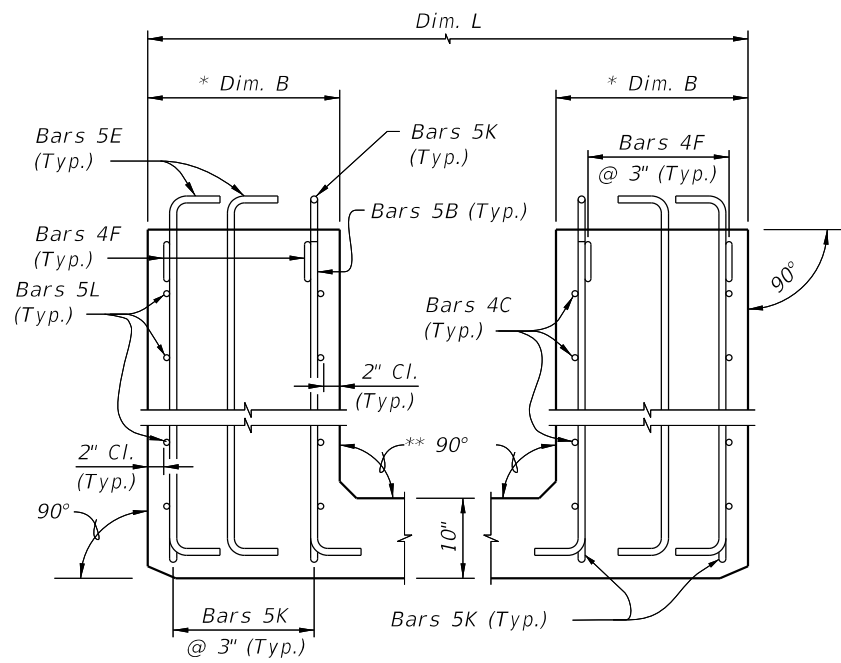

* Dim. B is 1'-6" for Florida-U 48 and 54 Beams and 2'-0" for Florida-U 63 and 72 Beams.

** Note 4, Sheet 1.

CONDITION 1
(P = 0.0)

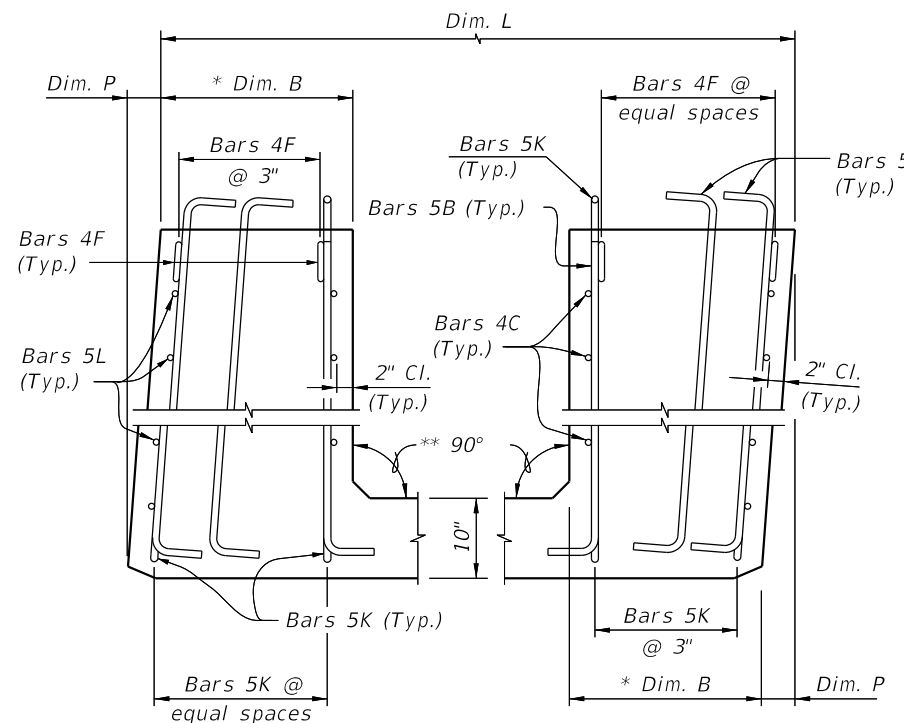

CONDITION 2

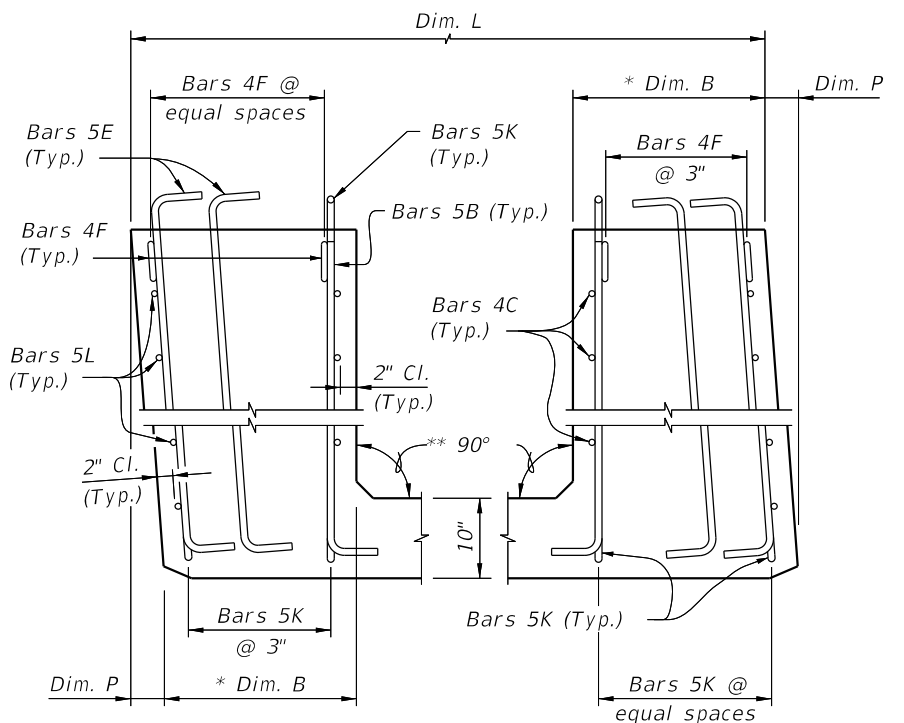

CONDITION 3

SCHEMATIC END ELEVATIONS OF BEAMS
(Showing Vertical Bevel of Beam End)

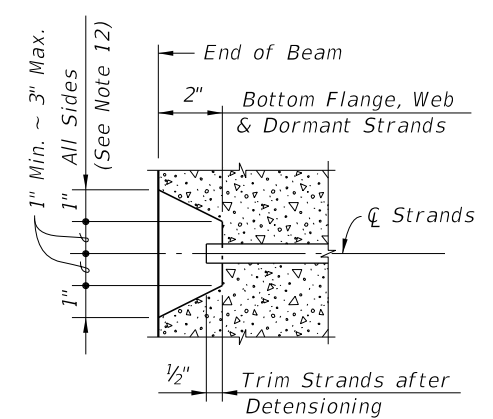

TYPICAL STRAND BLOCKOUT DETAIL

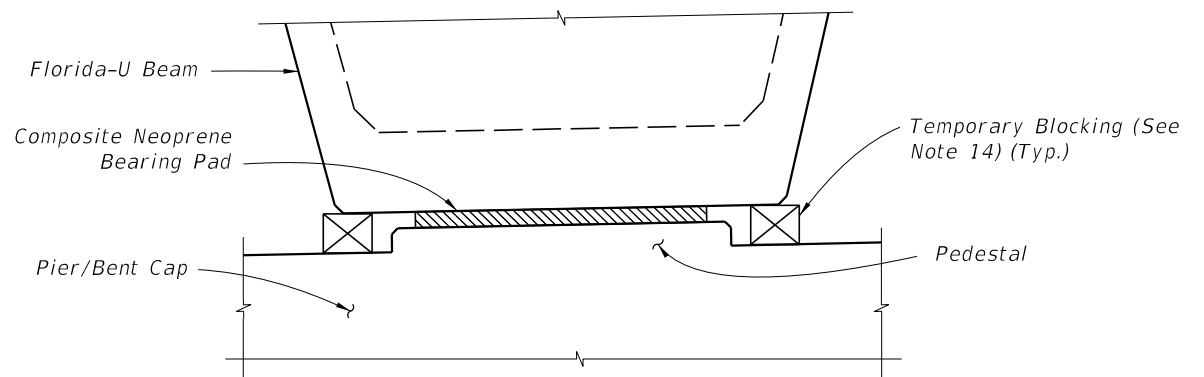

TEMPORARY BLOCKING OF BEAM ENDS

10/8/2020 10:36:32 AM

LAST REVISION 11/01/16	DESCRIPTION:	 FY 2021-22 STANDARD PLANS	FLORIDA-U BEAM - TYPICAL DETAILS & NOTES	INDEX 450-210	SHEET 2 of 2
---------------------------	--------------	--	--	------------------	-----------------