

PARTIAL PLAN - APPROACH TRANSITION

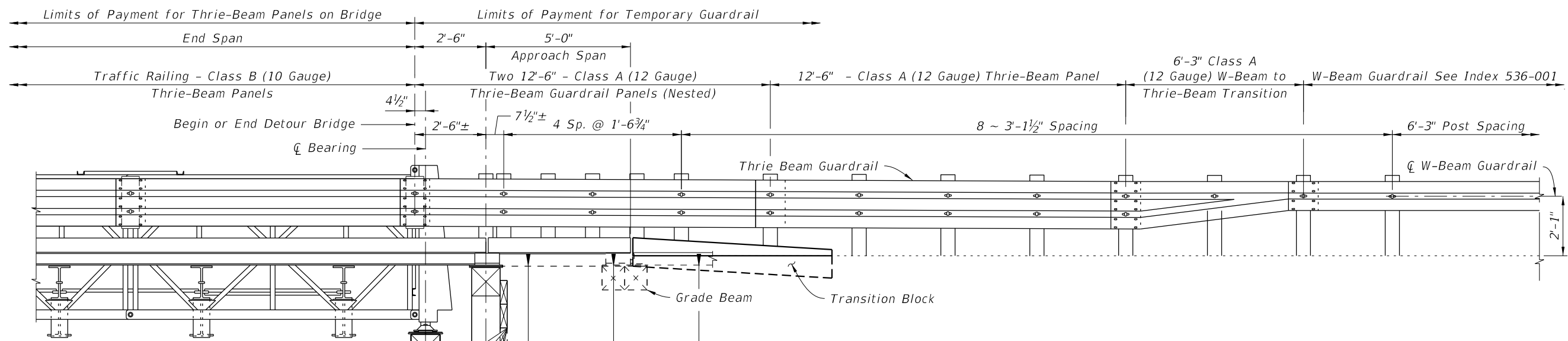

PARTIAL ELEVATION - APPROACH TRANSITION

10/8/2020 10:43:44 AM

LAST REVISION 07/01/15	DESCRIPTION:	 FY 2021-22 STANDARD PLANS	TEMPORARY DETOUR BRIDGE THRIE-BEAM GUARDRAIL	INDEX 102-240	SHEET 1 of 6
---------------------------	--------------	--	---	------------------	-----------------

THRIE-BEAM GUARDRAIL APPROACH TRANSITION

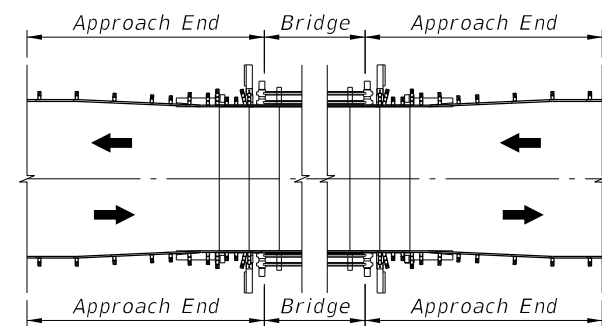
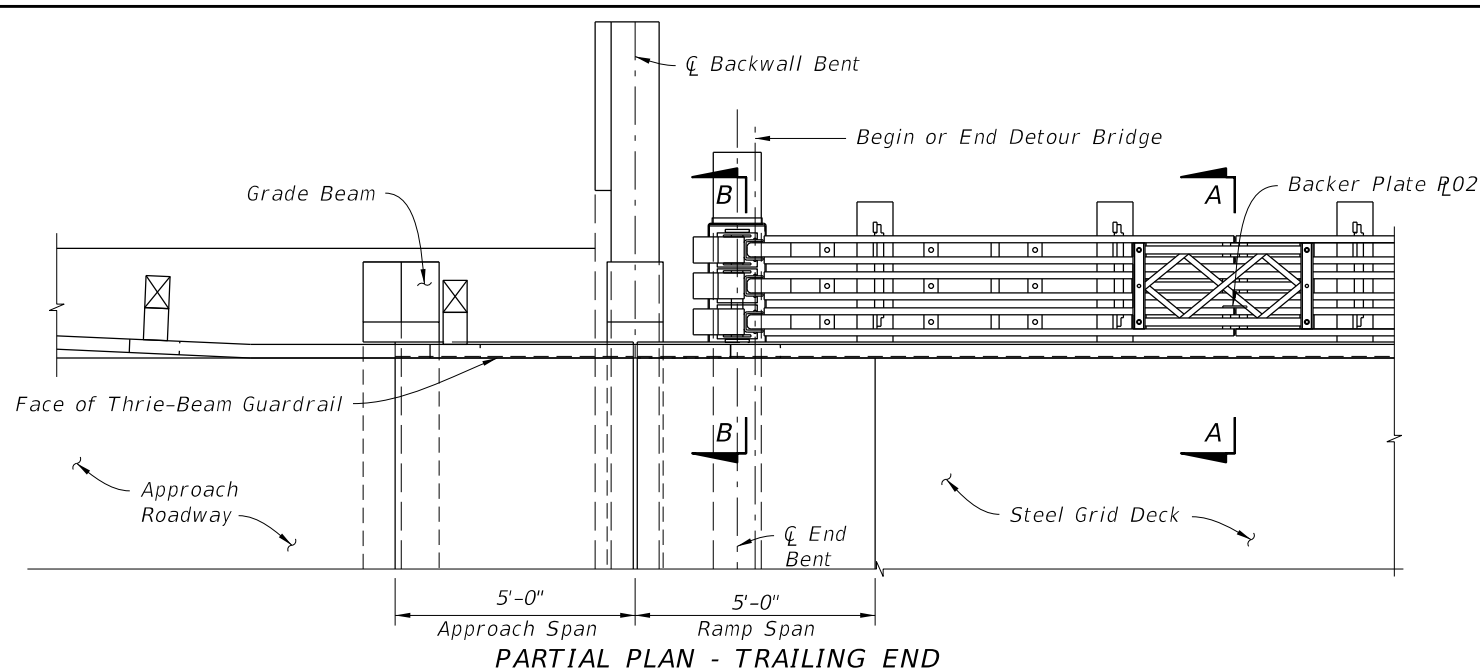

TWO-WAY TRAFFIC

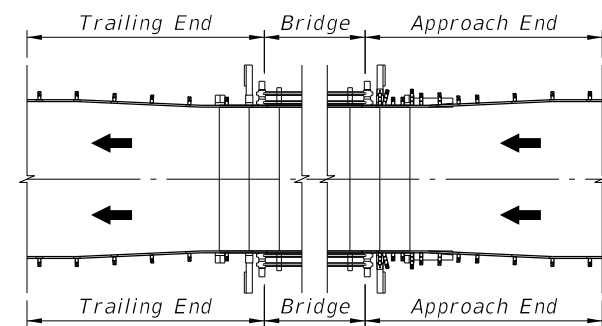
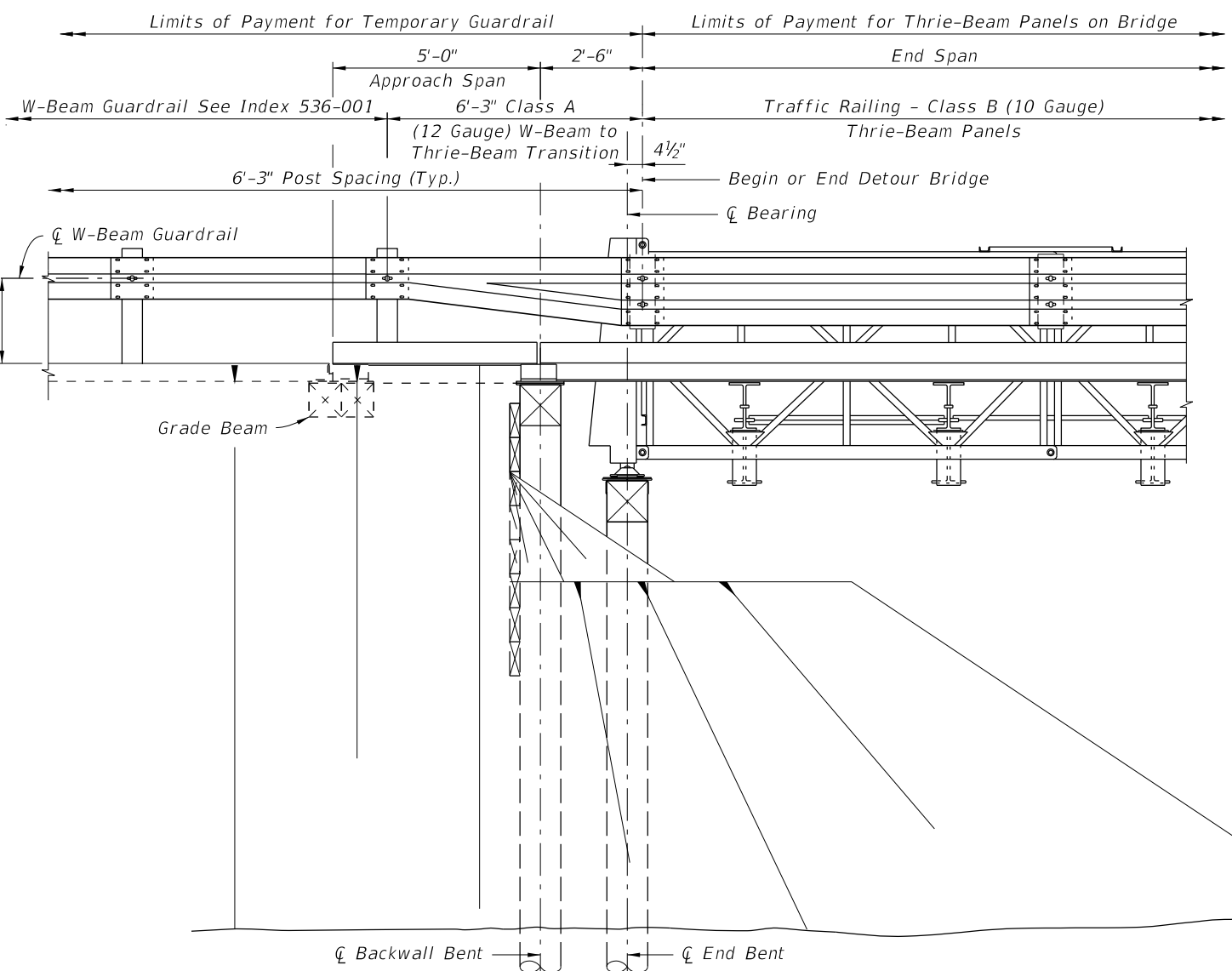

ONE-WAY TRAFFIC

END TRANSITION APPLICATION DETAILS

PARTIAL ELEVATION - TRAILING END

THRIE-BEAM GUARDRAIL TRAILING END TRANSITION

10/8/2020 10:43:46 AM

LAST REVISION 07/01/15	DESCRIPTION:
---------------------------	--------------



 FY 2021-22
 STANDARD PLANS

TEMPORARY DETOUR BRIDGE
 THRIE-BEAM GUARDRAIL

INDEX 102-240	SHEET 2 of 6
------------------	-----------------

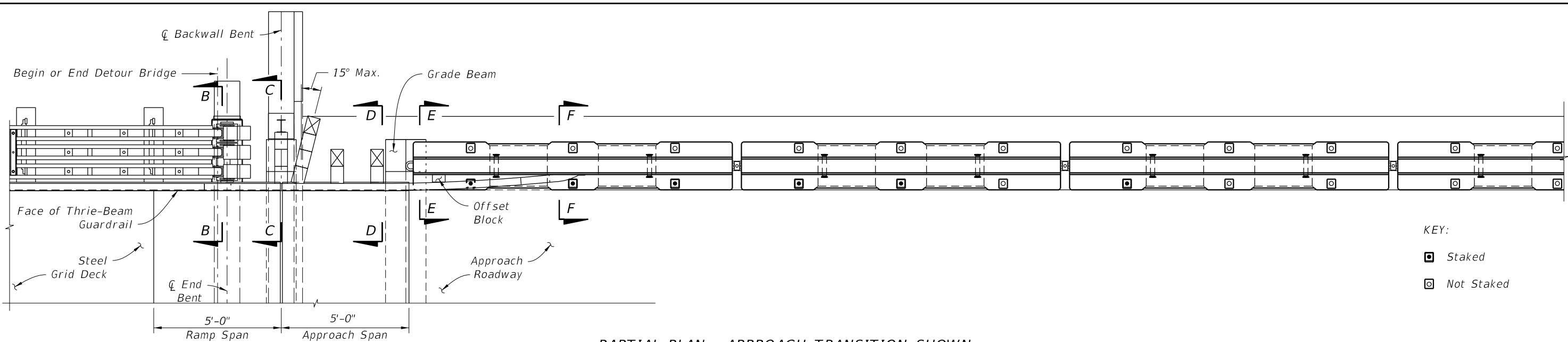

PARTIAL PLAN - APPROACH TRANSITION SHOWN
(TRAILING END SIMILAR)

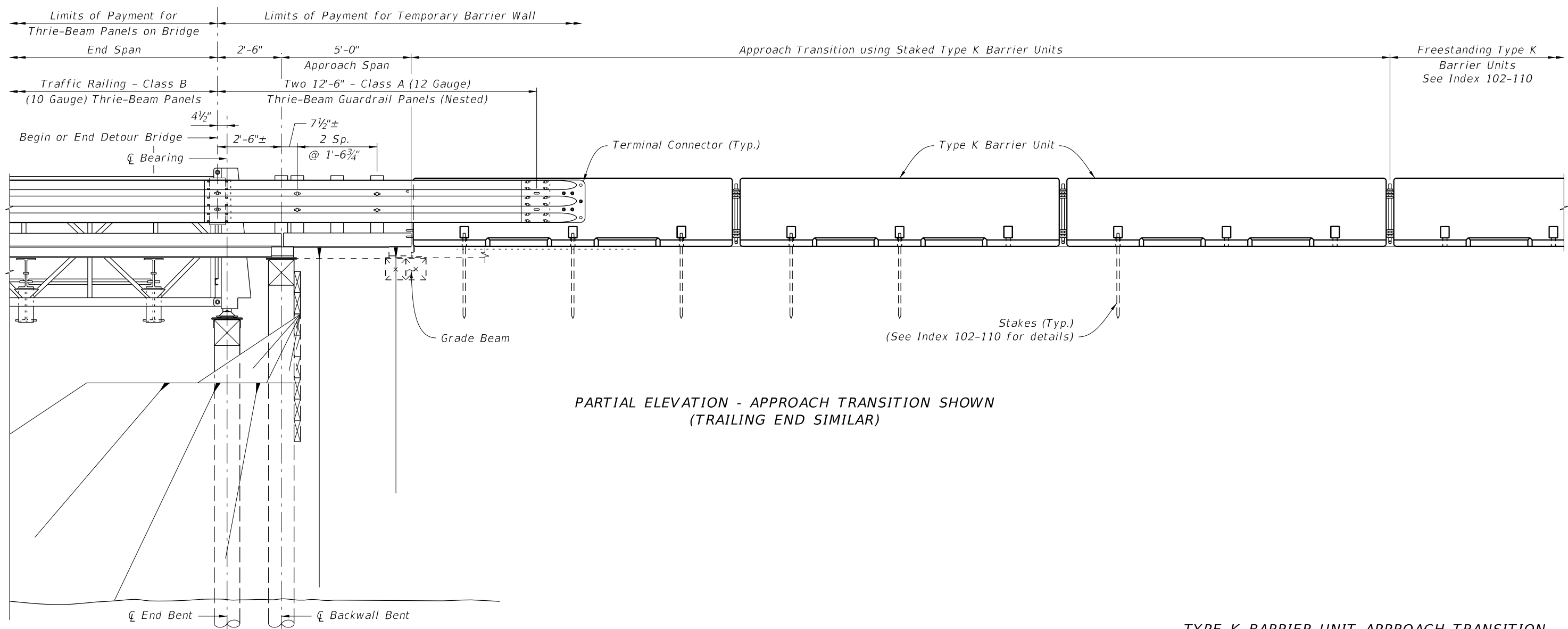

PARTIAL ELEVATION - APPROACH TRANSITION SHOWN
(TRAILING END SIMILAR)

10/8/2020 10:43:48 AM

TYPE K BARRIER UNIT APPROACH TRANSITION

LAST REVISION 07/01/15	REVISION	DESCRIPTION:
---------------------------	----------	--------------



FY 2021-22
STANDARD PLANS

TEMPORARY DETOUR BRIDGE
THRIE-BEAM GUARDRAIL

INDEX
102-240

SHEET
3 of 6

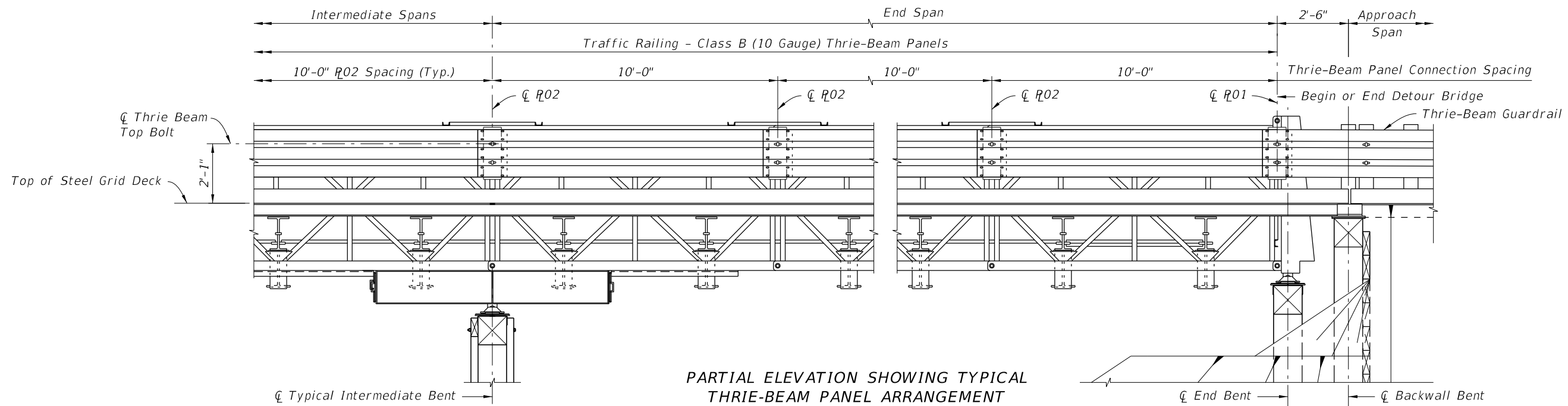

PARTIAL ELEVATION SHOWING TYPICAL THRIE-BEAM PANEL ARRANGEMENT

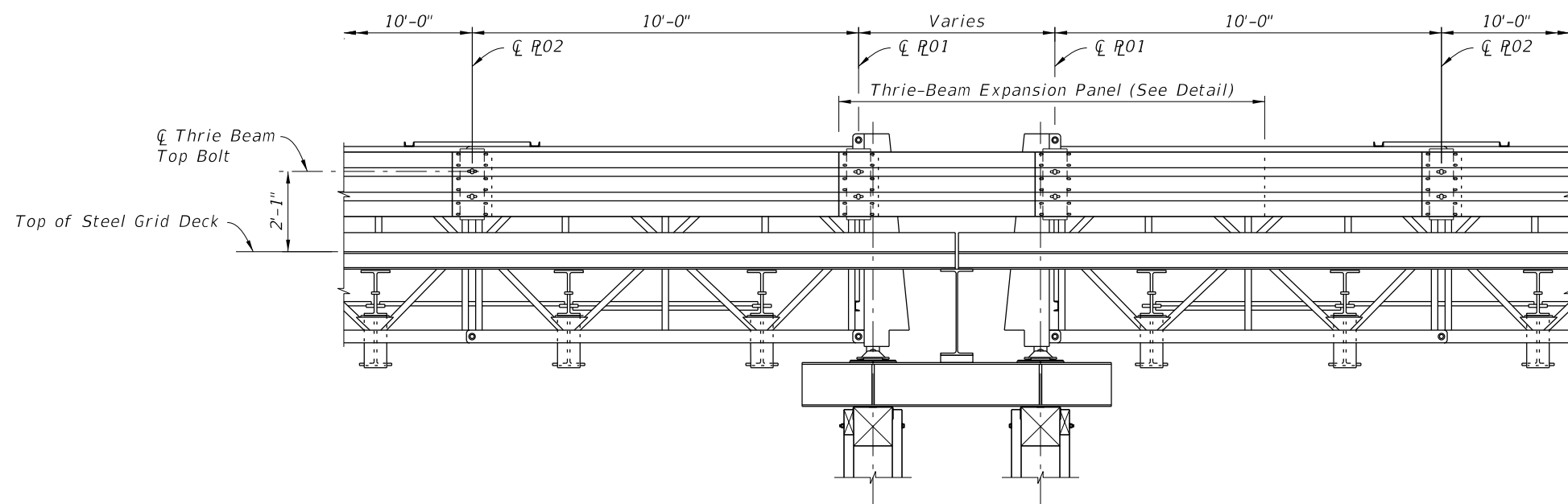

PARTIAL ELEVATION SHOWING THRIE-BEAM PANELS AT EXPANSION JOINT

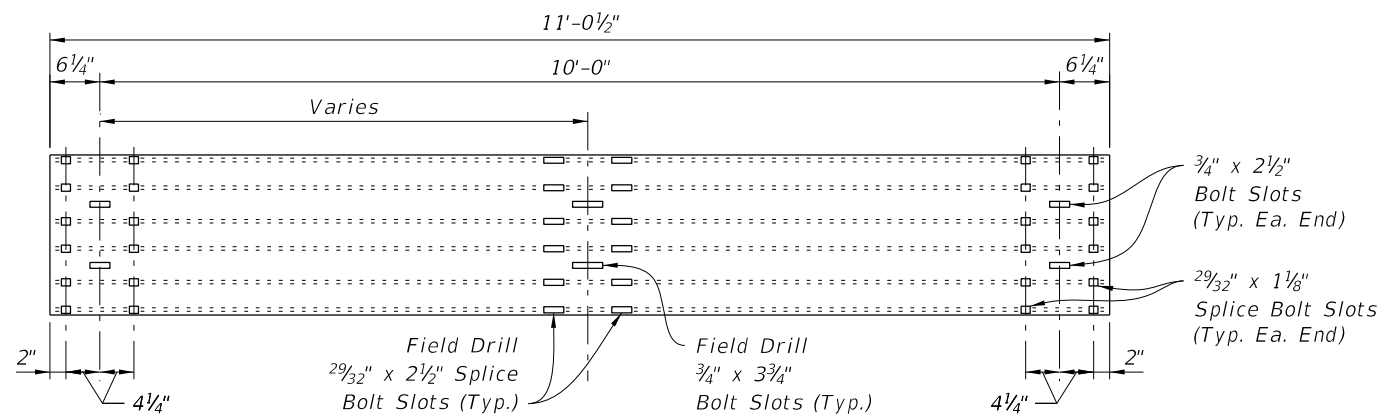

THRIE-BEAM EXPANSION PANEL DETAIL

10/8/2020 10:43:50 AM

LAST REVISION 07/01/15	REVISION	DESCRIPTION:
---------------------------	----------	--------------



FY 2021-22
STANDARD PLANS

TEMPORARY DETOUR BRIDGE
THRIE-BEAM GUARDRAIL

INDEX
102-240

SHEET
4 of 6

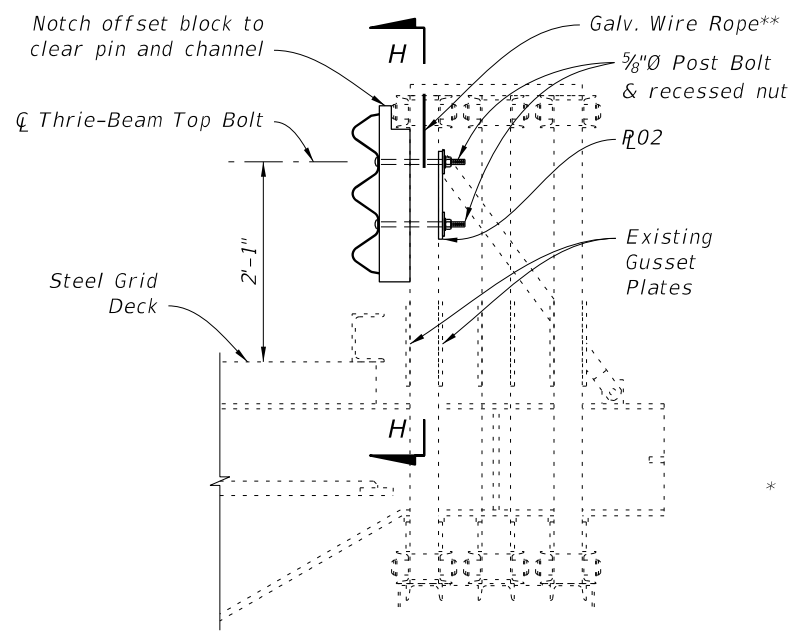

SECTION A-A

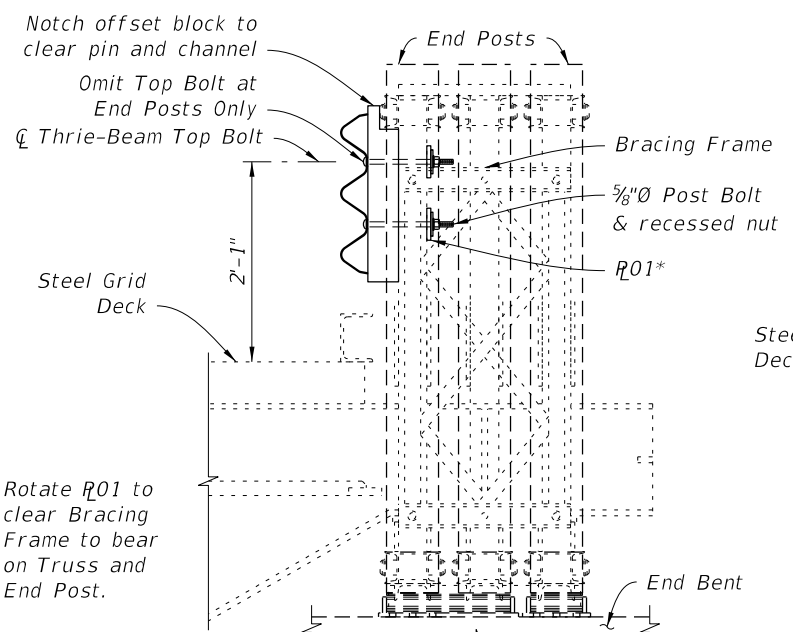

SECTION B-B

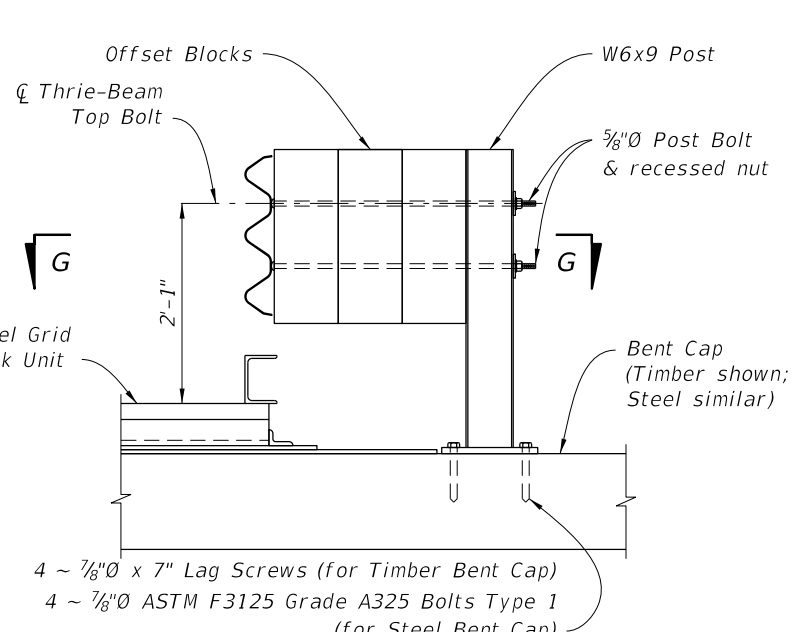

SECTION C-C

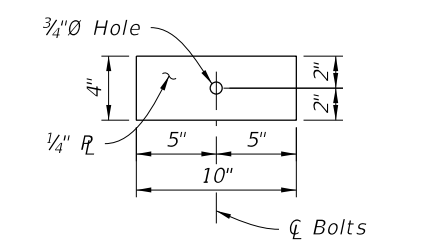

BACKER PLATE R01 DETAIL

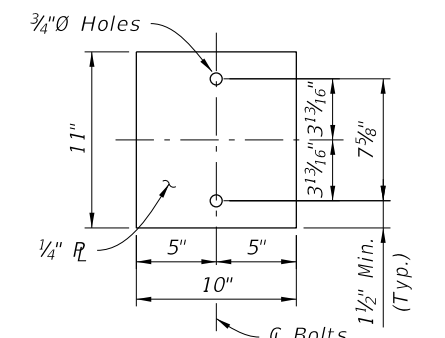

BACKER PLATE R02 DETAIL

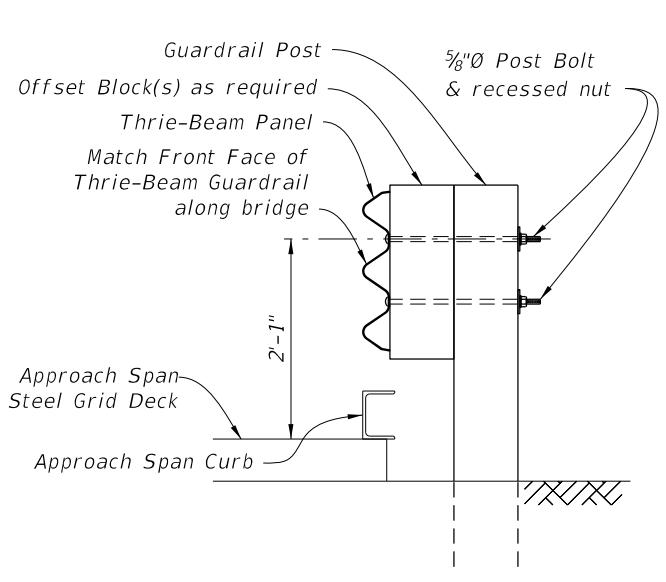

SECTION D-D

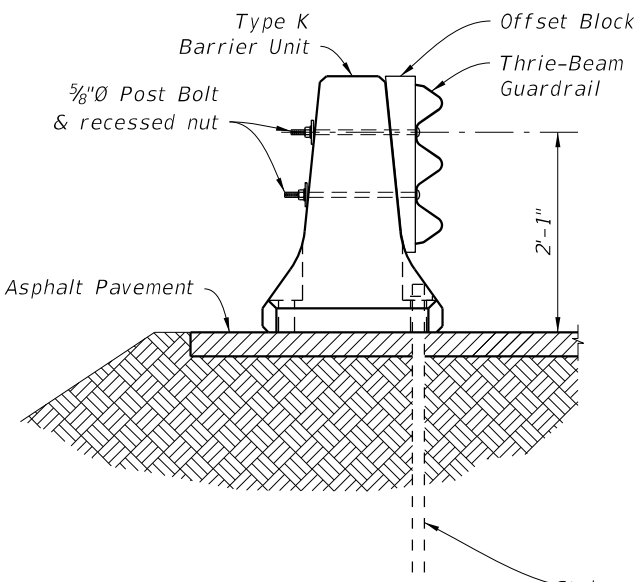

SECTION E-E

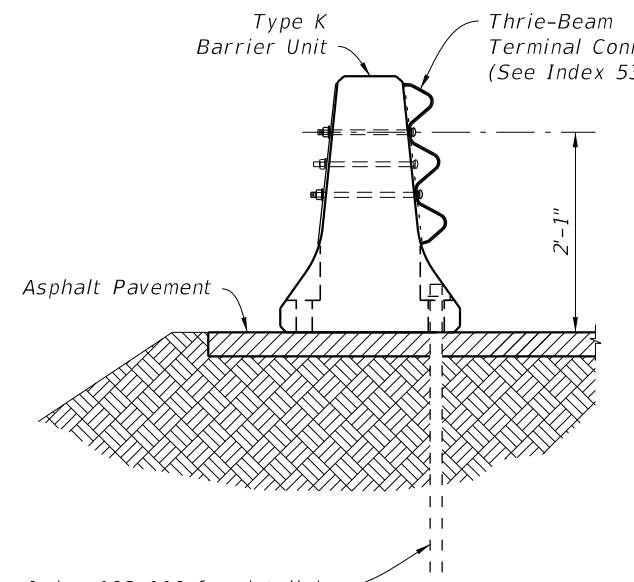

SECTION F-F

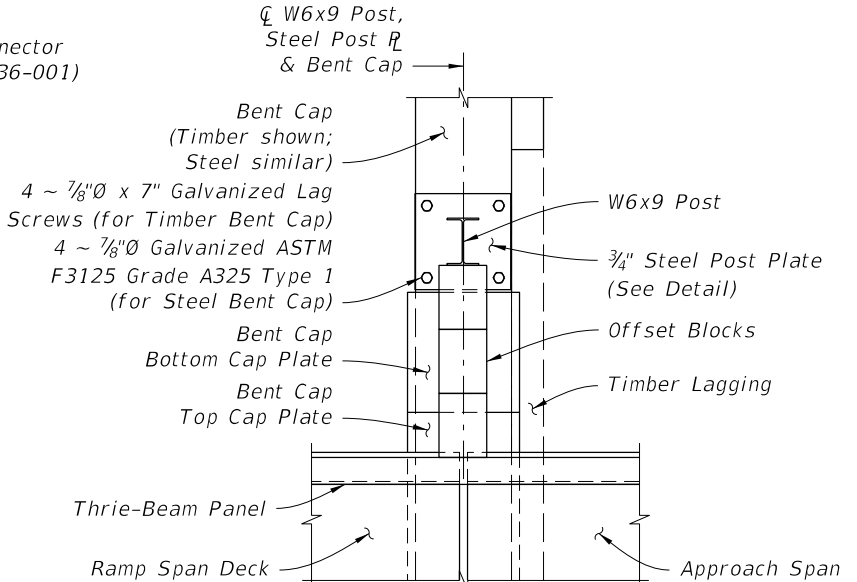

VIEW G-G

(Adjacent Post and Offset Blocks not shown for clarity)

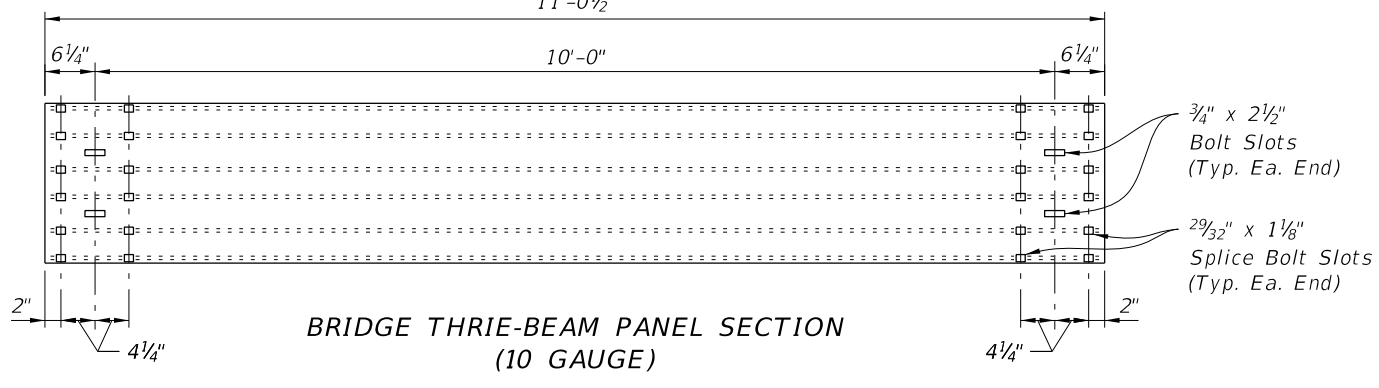

BRIDGE THRIE-BEAM PANEL SECTION (10 GAUGE)

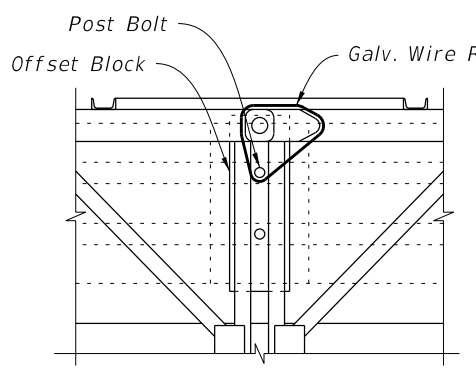

SECTION H-H

** As directed by the Engineer in order to limit vibration induced vertical displacement of the Thrie-Beam Panels, provide Contractor supplied, one time use, commercially available 3/16\"/>

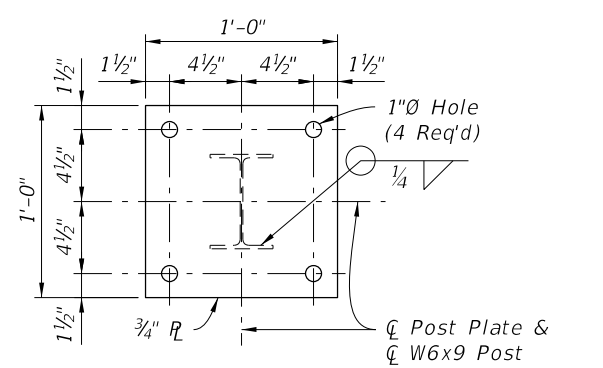

STEEL POST PLATE DETAIL

SECTIONS AND DETAILS

10/8/2020 10:43:52 AM

LAST REVISION 11/01/16	REVISION	DESCRIPTION:		FY 2021-22 STANDARD PLANS	TEMPORARY DETOUR BRIDGE THRIE-BEAM GUARDRAIL	INDEX 102-240	SHEET 5 of 6
---------------------------	----------	--------------	--	------------------------------	---	------------------	-----------------

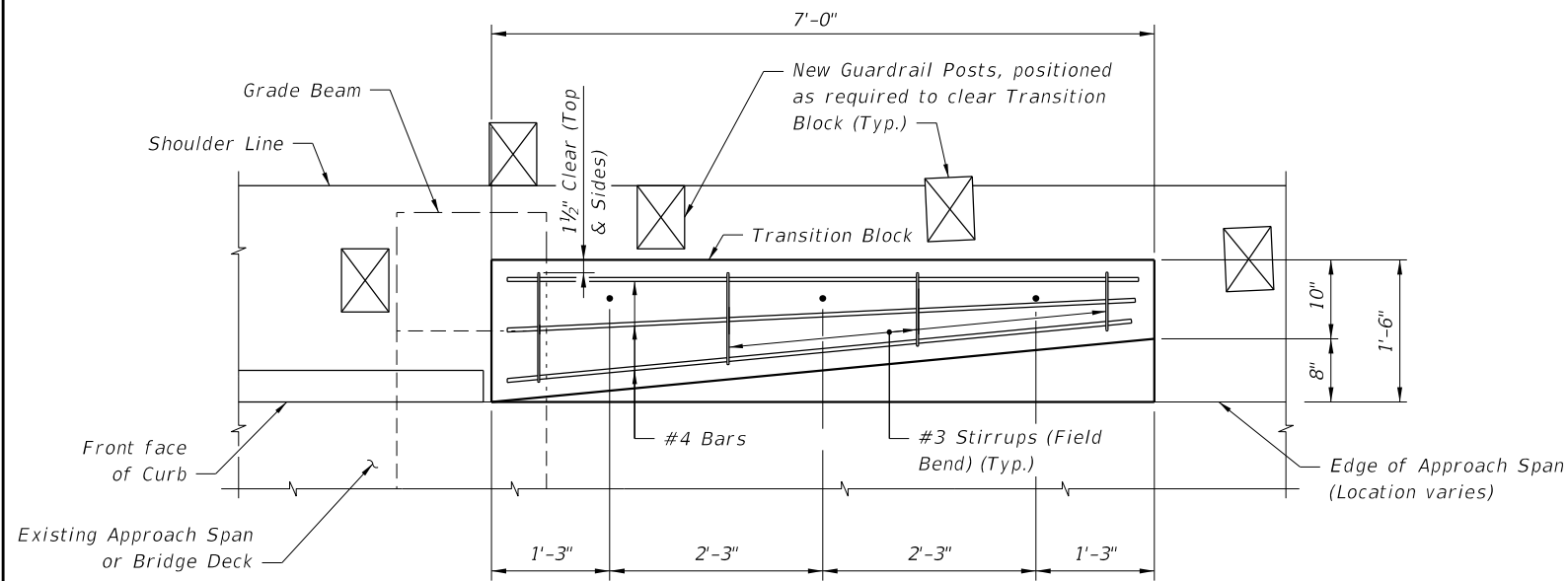

PLAN VIEW OF TRANSITION BLOCK
(GUARDRAIL NOT SHOWN FOR CLARITY)

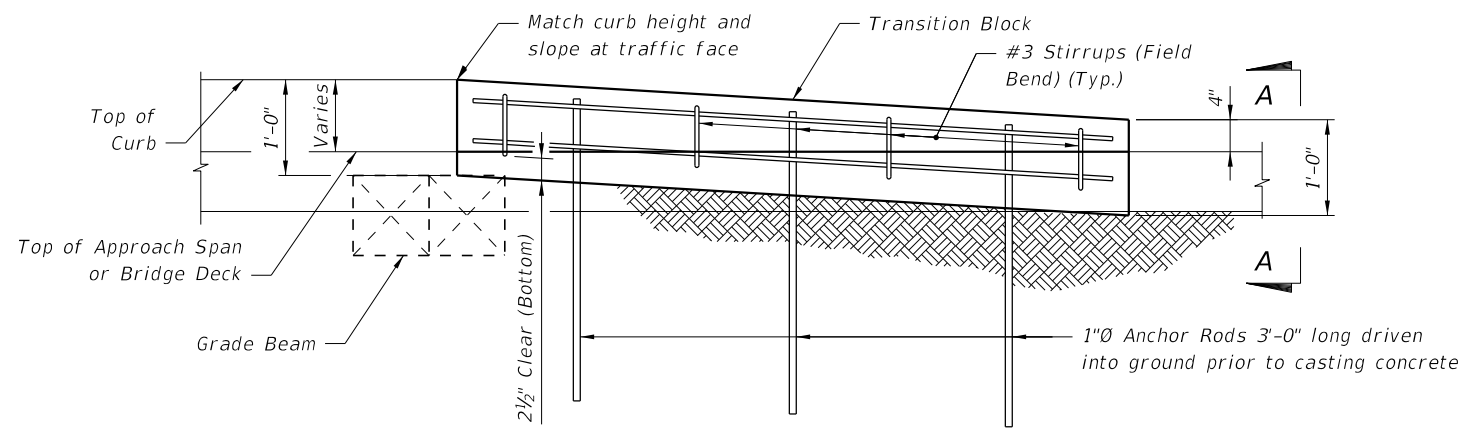

ELEVATION OF TRANSITION BLOCK
(GUARDRAIL AND POSTS NOT SHOWN FOR CLARITY)

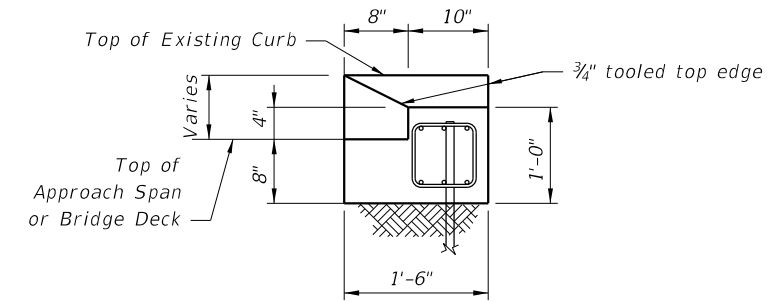

END VIEW A-A

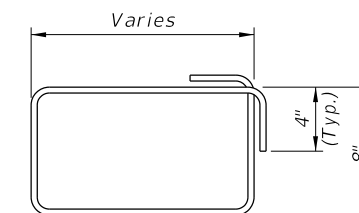

#3 STIRRUP (FIELD BEND)

NOTES:

REINFORCING STEEL: Reinforcing steel shall be ASTM A615, Grade 60.

ANCHOR RODS: Steel Anchor Rods shall be ASTM A36, ASTM A709 Grade 36 or ASTM A615 Grade 60 hot-dip galvanized in accordance with Specification Section 962.

ESTIMATED QUANTITIES

ITEM	UNIT	QUANTITY
Concrete Class NS	CY	0.4
Reinforcing Steel	LB	61
Guardrail (Reset)	LF	12.5

10/8/2020 10:44:06 AM

LAST REVISION 07/01/13	DESCRIPTION:
---------------------------	--------------



FY 2021-22
STANDARD PLANS

TEMPORARY DETOUR BRIDGE
THREE-BEAM GUARDRAIL

INDEX
102-240

SHEET
6 of 6