

10/12/2020 7:18:54 AM

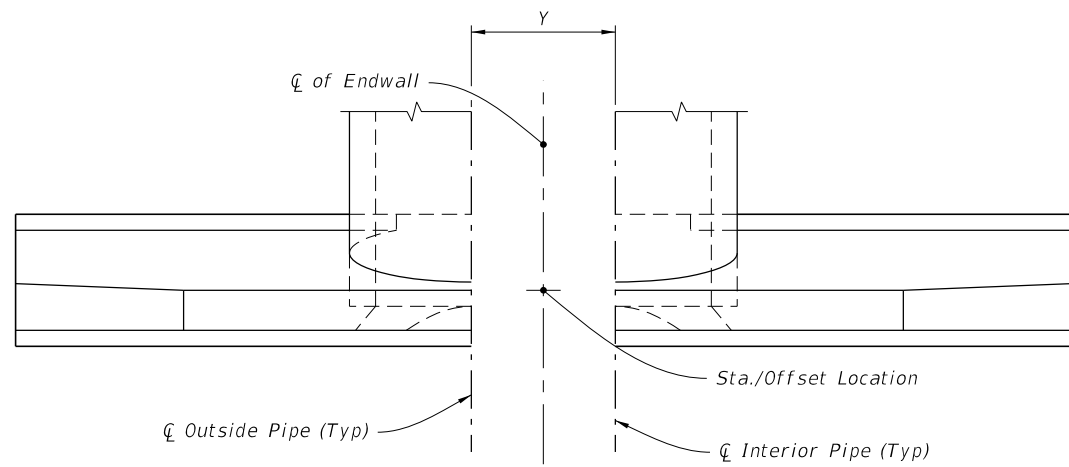

PLAN

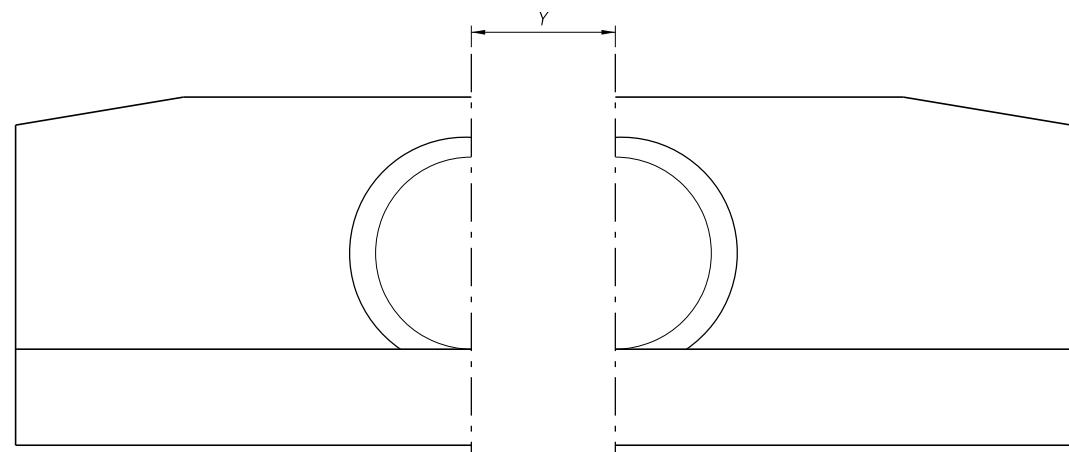

FRONT ELEVATION

NORMAL PIPE

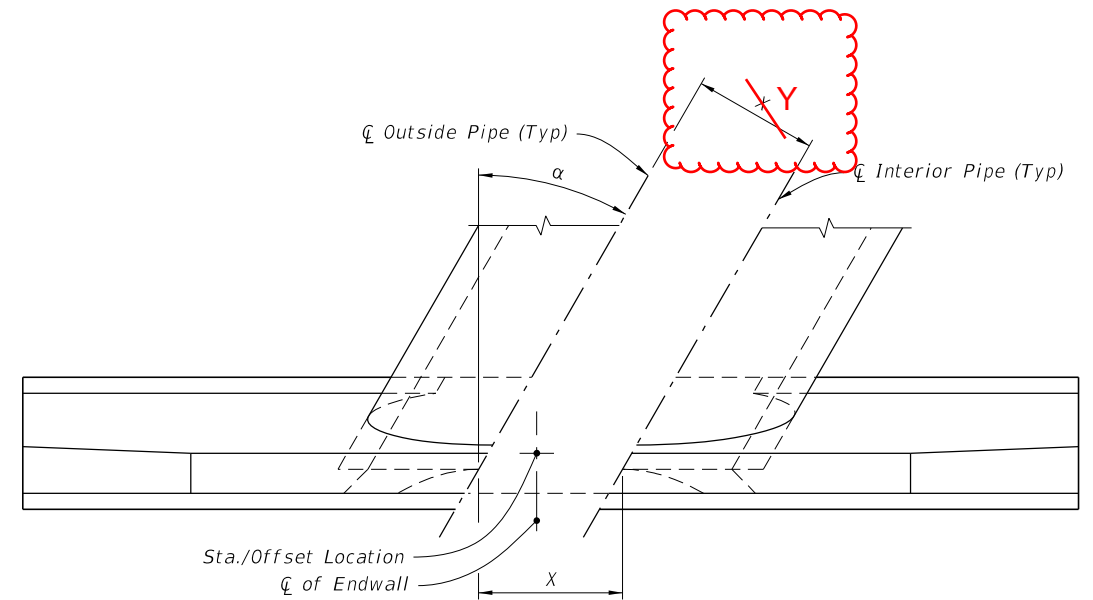

PLAN

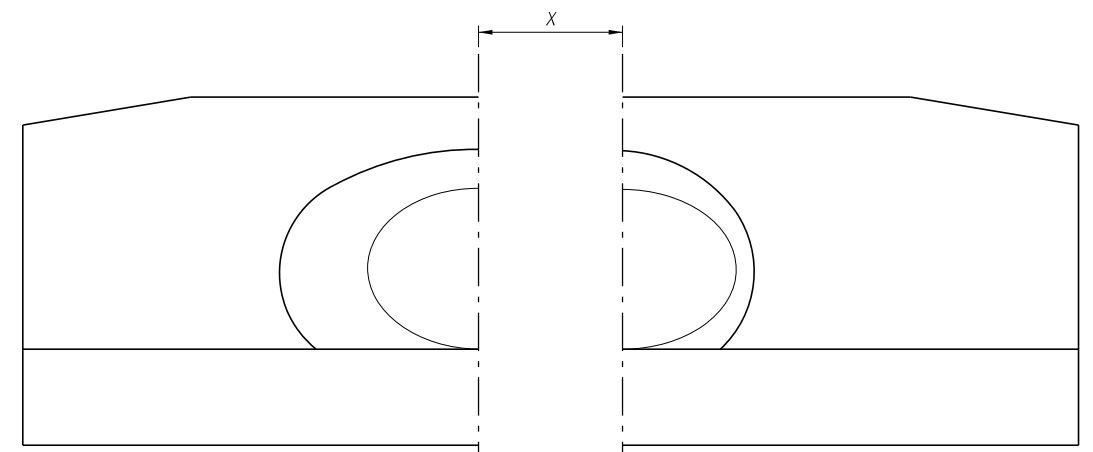

FRONT ELEVATION

SKewed PIPE

(Multiple Pipe Shown, Single Pipe Similar)

LEGEND:

- α Pipe Skew Angle
- Y Center to Center between pipes
- X Center to Center along front of Headwall

SPACING FOR MULTIPLE PIPES

LAST REVISION 11/01/19	DESCRIPTION:
---------------------------	--------------



FY 2021-22
STANDARD PLANS

STRAIGHT CONCRETE ENDWALLS
SINGLE AND MULTIPLE PIPE

INDEX
430-030

SHEET
4 of 4