

Index 515-062 Pedestrian/Bicycle Railing (Aluminum)

Design Criteria

Structures Design Guidelines (SDG 6.8); FDOT Design Manual (FDM)

Design Assumptions and Limitations

This railing is not applicable for shielding drop-off hazards for motor vehicle traffic. This railing is applicable for cases where a pedestrian or bicyclist drop-off hazard exceeds 5'-0" or when a drop-off hazard is less than 5'-0" and is required by design or permit stipulations. Refer to **FDM 222** for the definition of vehicular, pedestrian and bicyclist "drop-off hazards".

Indexes 515-052 and 515-062 are similar in form and function. Select which of these railings to use at a given site based on District preferences, aesthetic or finish color requirements, corrosion concerns, theft potential issues, fabrication issues, weight of railing and any other project specific requirements. In some cases, both of these railings are acceptable for use and the selection of which to provide is left to the contractor by the use of Pay Item 515-2-1BB.

See Index 515-061 for special requirements and modifications for use on bridges.

A handrail is required where there are 3 or more steps and on ramps with a grade steeper than 5% to conform to the requirements of the *Americans with Disabilities Act (ADA)*.

Expansion joints shall be spaced at a maximum 35'-0" (differs from Index 515-052). Railing must be continuous across a minimum of two posts.

For the railing anchorage to provide stability against overturning, the concrete foundation (sidewalk, retaining wall, curb, etc.) must meet or exceed the requirements in this Standard

For the purpose of these instructions, the following definitions shall apply:

4" Sphere Rule - Clear openings of the railing below 42" height shall reject the passage of a 4" diameter sphere and clear openings above 42" height shall reject the passage of an 8" diameter sphere.

6" Sphere Rule - Clear openings of the railing below 27" height shall reject the passage of a 6" diameter sphere and clear openings above 27" height shall reject the passage of an 8" diameter sphere.

Refer to the SDG for locations where the 4" Sphere rule is applicable. Providing adequate sight distance always takes priority over the 4" Sphere Rule.

Aesthetics play a crucial role in the determination of which railing infill type should be specified for a particular project. Alternate Infill Panel designs within the Standard Plans, include those that meet the 6" Sphere Rule and others that meet the 4" Sphere Rule. Custom Infill Panels must be designed to meet the Design Criteria live load, and the

applicable 4" or 6" Sphere Rule. When designing Infill Panels, aesthetics is important; however, line of sight and safety issues must be a priority.

Typically the clear space between the top and intermediate horizontal rails provides for adequate sight distances, however, for railing installations adjacent to sloped intersections, the infill area between the intermediate and bottom horizontal rails may still adversely affect the sight distance. Of the standard infill alternatives that meet the 4" Sphere Rule, the standard "Type 2 - Chain-Link" infill alternative creates the least obstruction to sight distance through the infill areas.

When a colored coating is desired and the additional cost is justified or reimbursed by the requesting local agency, then specify a coating complying with AAMA 2605, "Performance Requirements and Test Procedures for Superior Performing Organic Coatings on Aluminum Extrusions and Panels", (American Architectural Manufacturers Association, 2011) except that only fluoropolymer based powders are permitted. See FDM 127 for responsibilities of Local Maintaining Agencies.

Plan Content Requirements

In the Structures and/or Roadway Plans:

Show Pedestrian Railings on sidewalks and walls as required. Designate locations where handrails are required. Label railing by name or Index number.

When either Index 515-052 or 515-062 are acceptable, include cross references to both indexes and use Pay Item 515-2-1BB.

When the 4" Sphere Rule must be met, modifications to the picket spacing (Type 1 & 3 Infill Panels) and intermediate railing height will be required in the Plans. Modify the Standard Plans in accordance with Method 1, Method 2 or Method 3 as defined in the Terms Of Use for the Borderless DGNs provided in the Standard Plans eBooklet.

Prepare project specific Infill Panel details when required using the Pedestrian/Bicycle Railing Custom Infill Panel CADD cell and include them in the plans. Designate each individual project specific Infill Panel with a unique name for identification and cross reference purposes.

All custom Infill Panels shall be fully detailed in the contract plans. A Custom Type Infill Panel Cell, as shown below, is available through the Structures CADD bar menu.

Complete the following Data Tables and include them in the plans. See Introduction I.3 for more information regarding use of Data Tables.

In the HEIGHT column of the Data Table, enter either "42" for standard Pedestrian/Bicycle Railing, "48" for Special Height Bicycle Railing, or required height where modified railing height is required.

In the STYLE column of the Data Table, enter either "Type X" (where X = 1 thru 5 for the standard Infill Panel options) or "Custom" where custom Infill Panels are fully detailed in the plans.

ALUMINUM PEDESTRIAN/BICYCLE RAILING DATA TABLES

PROJECT REQUIREMENTS					Table Date 01-01-11
Station to Station (Lt. or Rt.)	Height (in.)	Style Type (1)	Required: (Yes/No)		
			Bottle Guard	Colored Coatings (2)	Infill Panel to Reject Passage of 4" Sphere (Special conditions only)

(1) For "CUSTOM" Style Types, see plans for in-fill panel details.
 (2) The color shall be per Federal Color Chart, Federal Standard No. 595B, Table _____, Color _____.

NOTES:
 1. Work this Data Table with Index 515-062.

ALUMINUM PEDESTRIAN/BICYCLE RAILING CUSTOM TYPE INFILL PANEL DETAILS

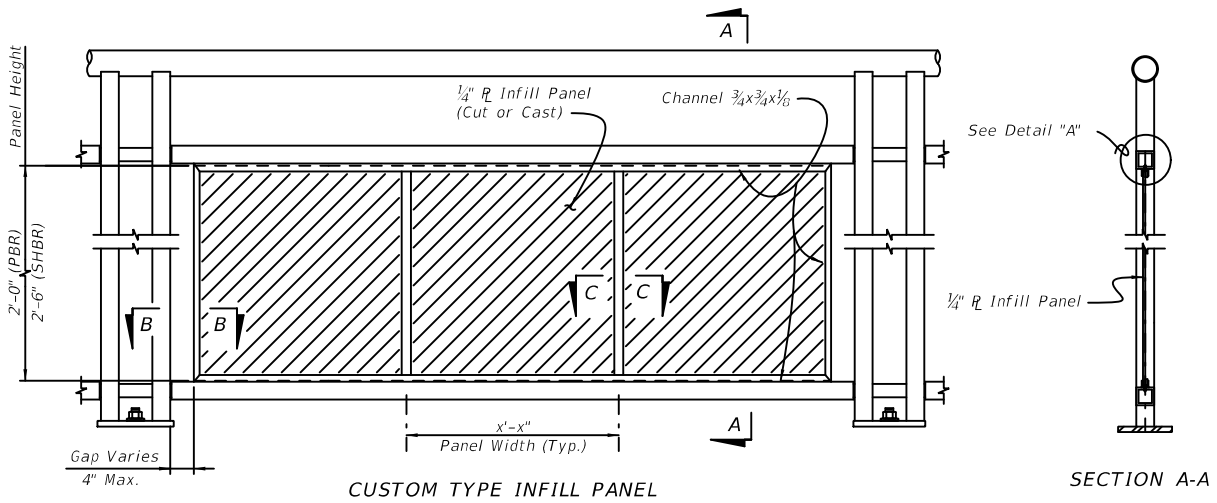

Notes:
 PBR = 42" Pedestrian/Bicycle Railing
 SHBR = 48" Special Height Bicycle Railing

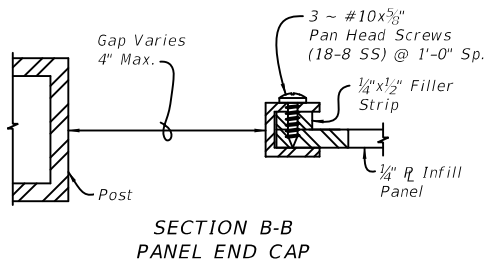
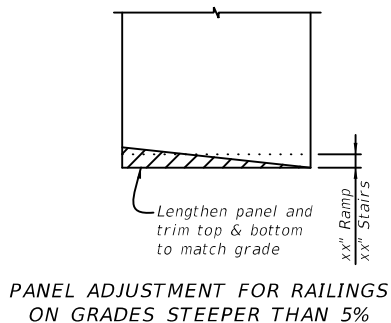
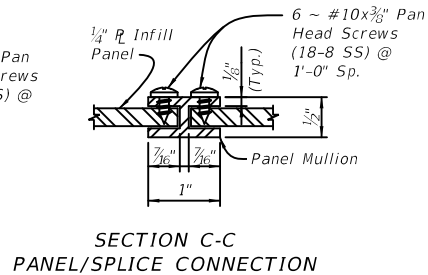
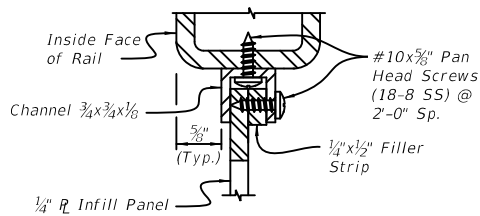

Payment

Item number	Item Description	Unit Measure
515-2-1BB	Pedestrian / Bicycle Railing, Non Specified, 42" (Type___)	LF
515-2-1BB	Pedestrian / Bicycle Railing, Non Specified, 48" (Type___)	LF
515-2-3BB	Pedestrian / Bicycle Railing, Aluminum Only, 42" (Type___)	LF
515-2-3BB	Pedestrian / Bicycle Railing, Aluminum Only, 48" (Type___)	LF