

GENERAL NOTES:

1. Work this Index with Specification 700.
2. Shop Drawings are required:
 - A. Provide length as shown in the Plans
 - B. Design in accordance with AISC, AASHTO, and OSHA requirements
 - B. Do not start fabrication until the shop drawings are approved
3. Catwalk hangers must be positioned to avoid conflicts with the sign structure truss and gusset plates. Place walkway close to the sign with a maximum open distance from walkway grate to DMS sign of 1/2".
4. Maximum spacing of Catwalk hanger supports is 5'-0". Cantilever ends of grating is 8".
5. Galvanized steel catwalk grating meeting the requirements of Specification 504-2.3. Must Support a 90 psf load and have a 3 1/2" minimum toe kick. Attach grating in accordance with the manufacturer's instructions using stainless steel or galvanized fasteners.
6. Supply and install an OSHA 1910 compliant, self closing, corrosion resistant safety gate.
7. Chain link fabric options (2" mesh with knuckled selvage top and bottom for all options):
 - A. AASHTO M181 Type I - Zinc Coated Steel, No. 9 gage (coated wire diameter), coated at the rate of 1.8 oz./ft². (M181 Class D 2.0 oz./ft². modified to 1.8 oz./ft²).
 - B. AASHTO M181 Type II - Aluminum Coated Steel, No. 9 gage (coated wire diameter), coated at the rate of 0.40 oz./ft².
8. Install 2" NPS (Sch. 40) guiderail and posts: ASTM A53 Grade B for standard weight pipe.
9. Welding:
E70XX
10. Materials:
 - A. Steel Plates ASTM A 36 or A709 Grade 36.
 - B. W- Sections: ASTM A572 Grade 36 or 50.
 - C. Steel Pipe Railings or Structural Tubing: Specification 962
 - D. High Strength Bolts, Nuts and Washers: Specification 962
 - E. U-Bolts, nuts and washers: Specification 962
11. Coatings/Galvanizing:
Hot dip galvanize support frame after fabrication and galvanize non-stainless steel fasteners in accordance with Specification 962.

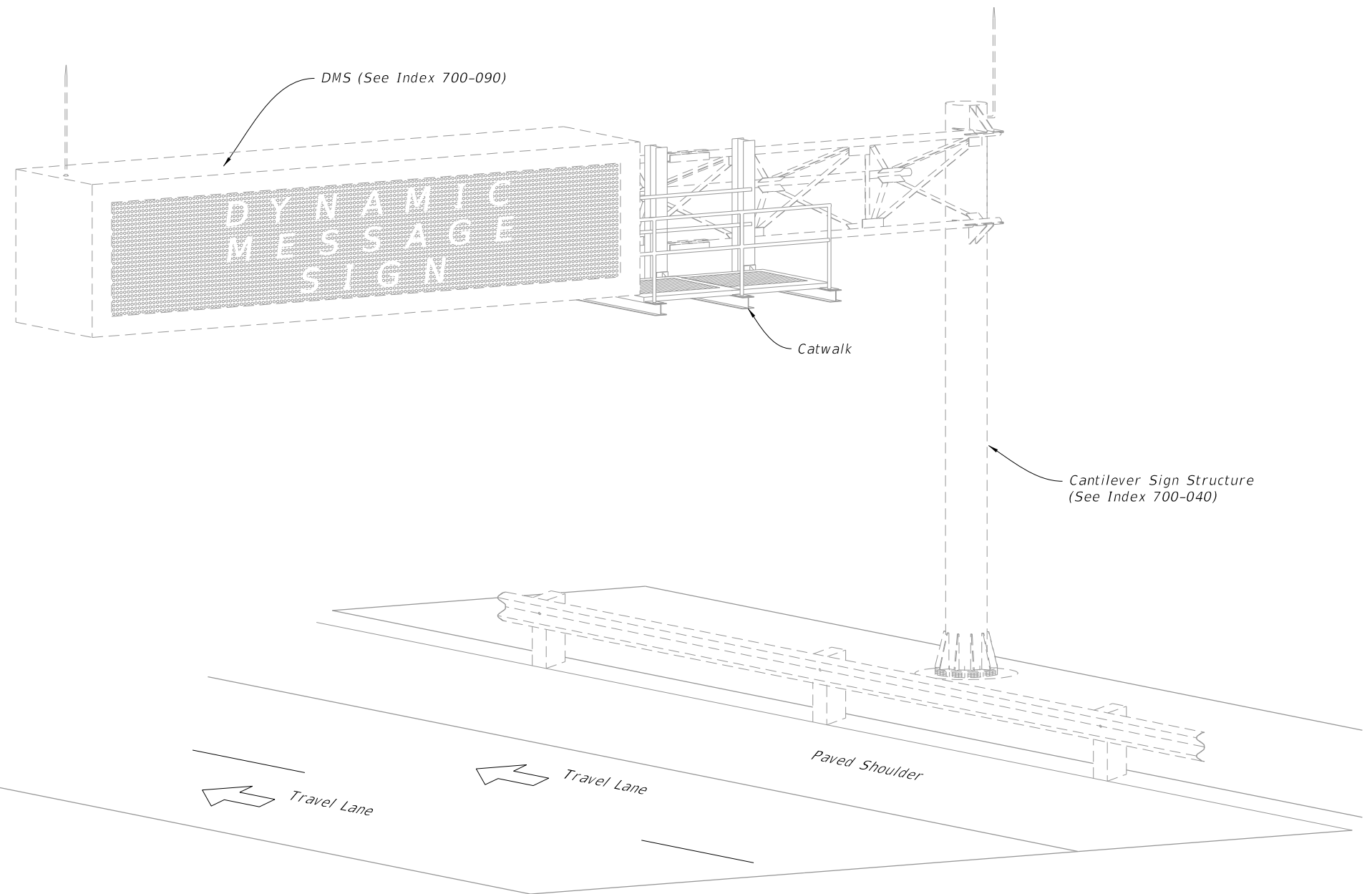

CATWALK ASSEMBLY
(Cantilever Shown, Span Similar)

TABLE OF CONTENTS:

Sheet	Description
1	General Notes and Content
2	General Assembly and Fixed Base Details
3	Walkway Support Details

10/14/2019 2:41:05 PM

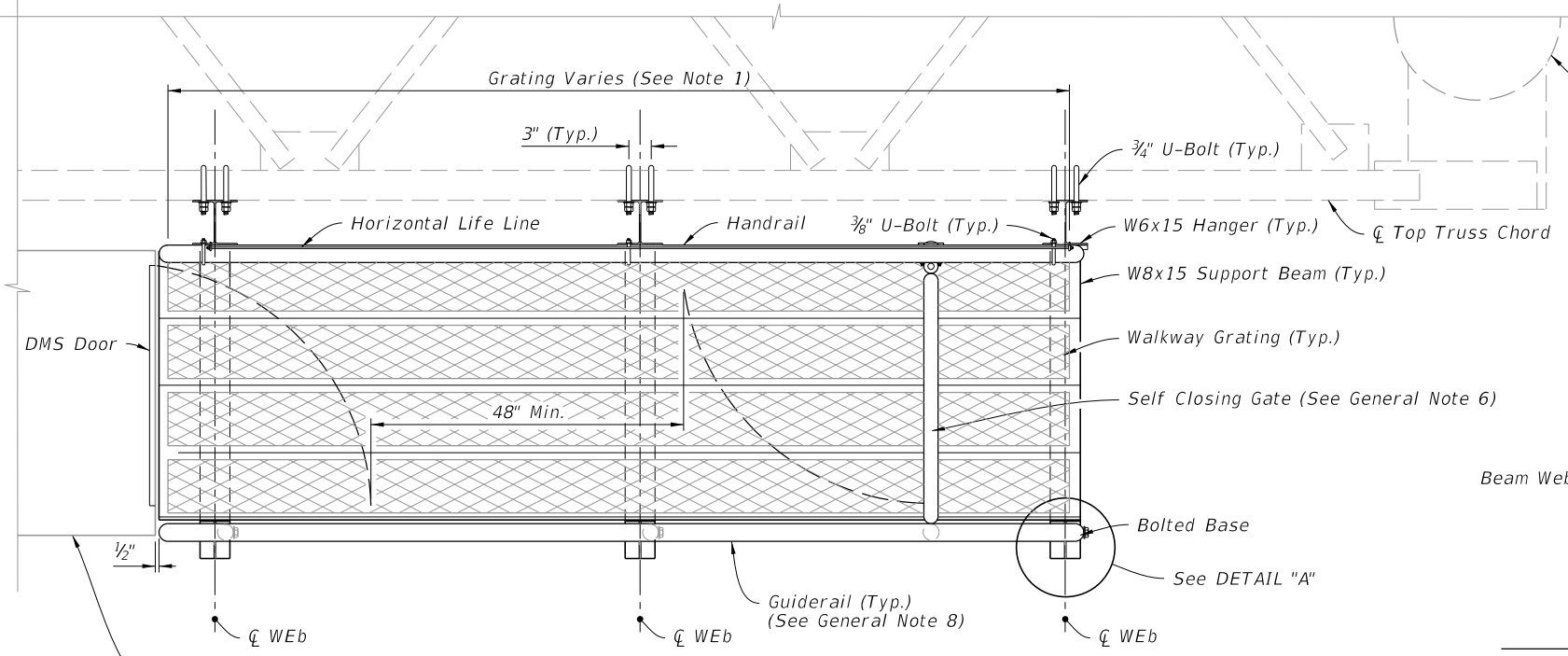

PLAN

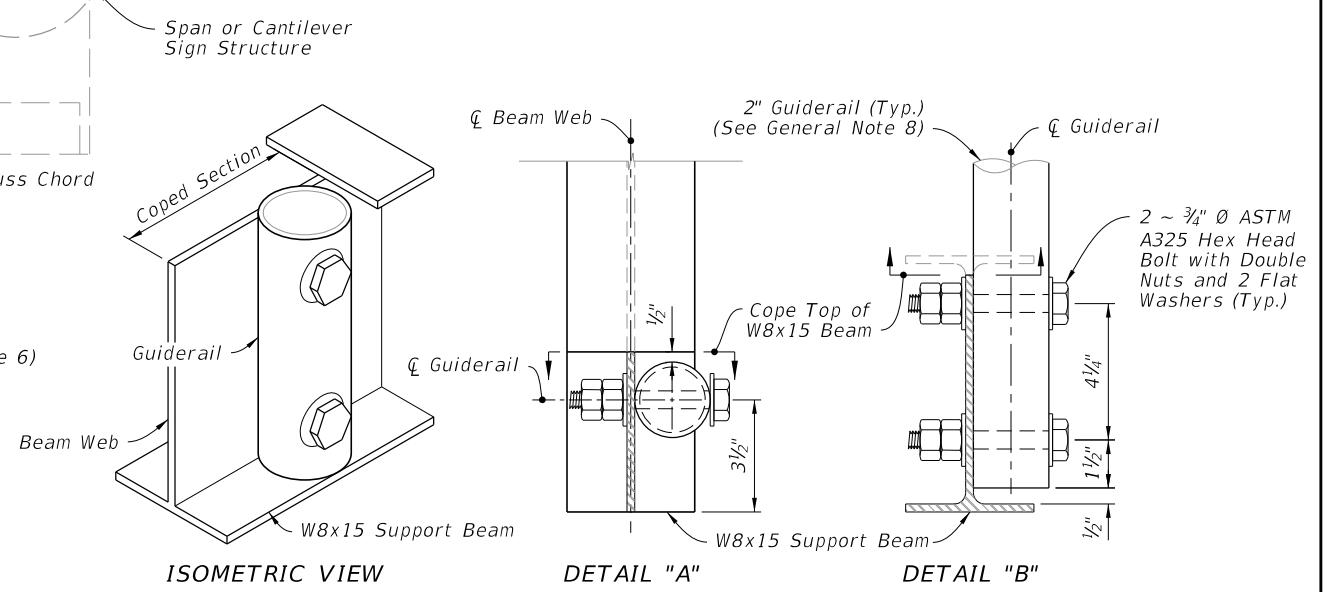

BOLTED BASE DETAILS

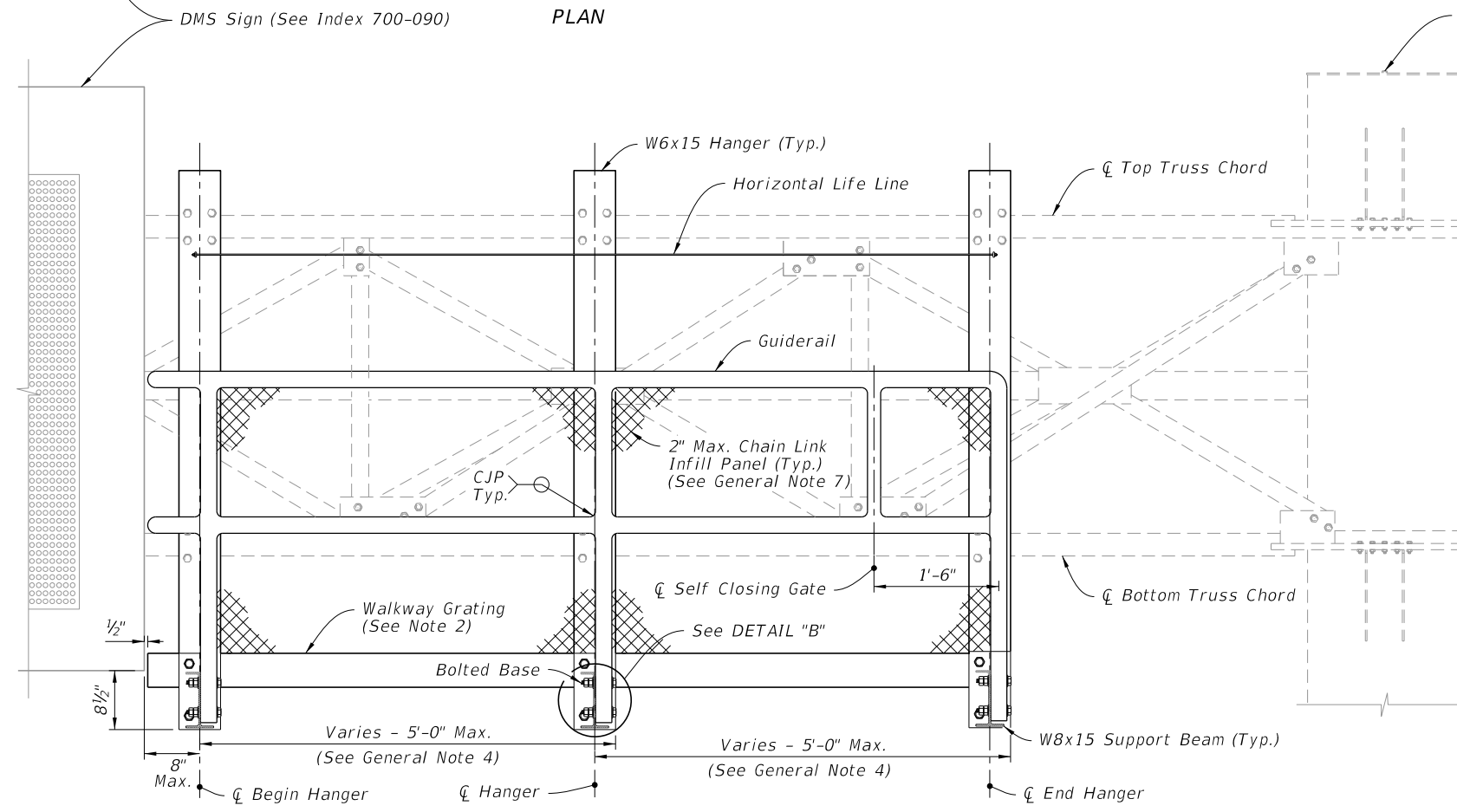

FRONT ELEVATION

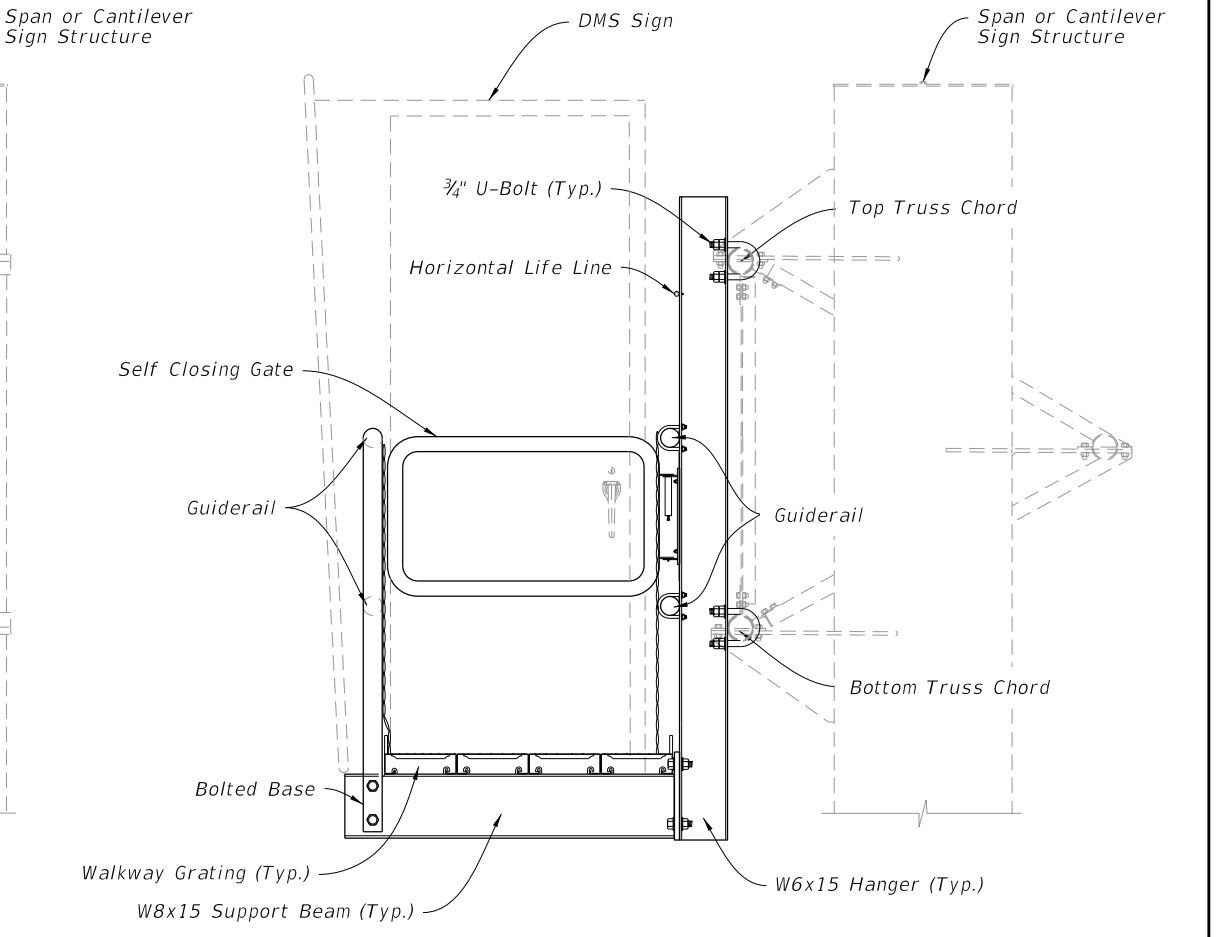

SIDE ELEVATION

GENERAL ASSEMBLY

- NOTES:**
1. See manufacturer details for walkway planks and bolting criteria.
 2. Fasten securely. See grating manufactures details.

GENERAL ASSEMBLY AND FIXED BASE DETAILS

10/14/2019 2:41:06 PM

LAST REVISION	DESCRIPTION:
11/01/19	



**FY 2020-21
STANDARD PLANS**

CATWALK DETAILS

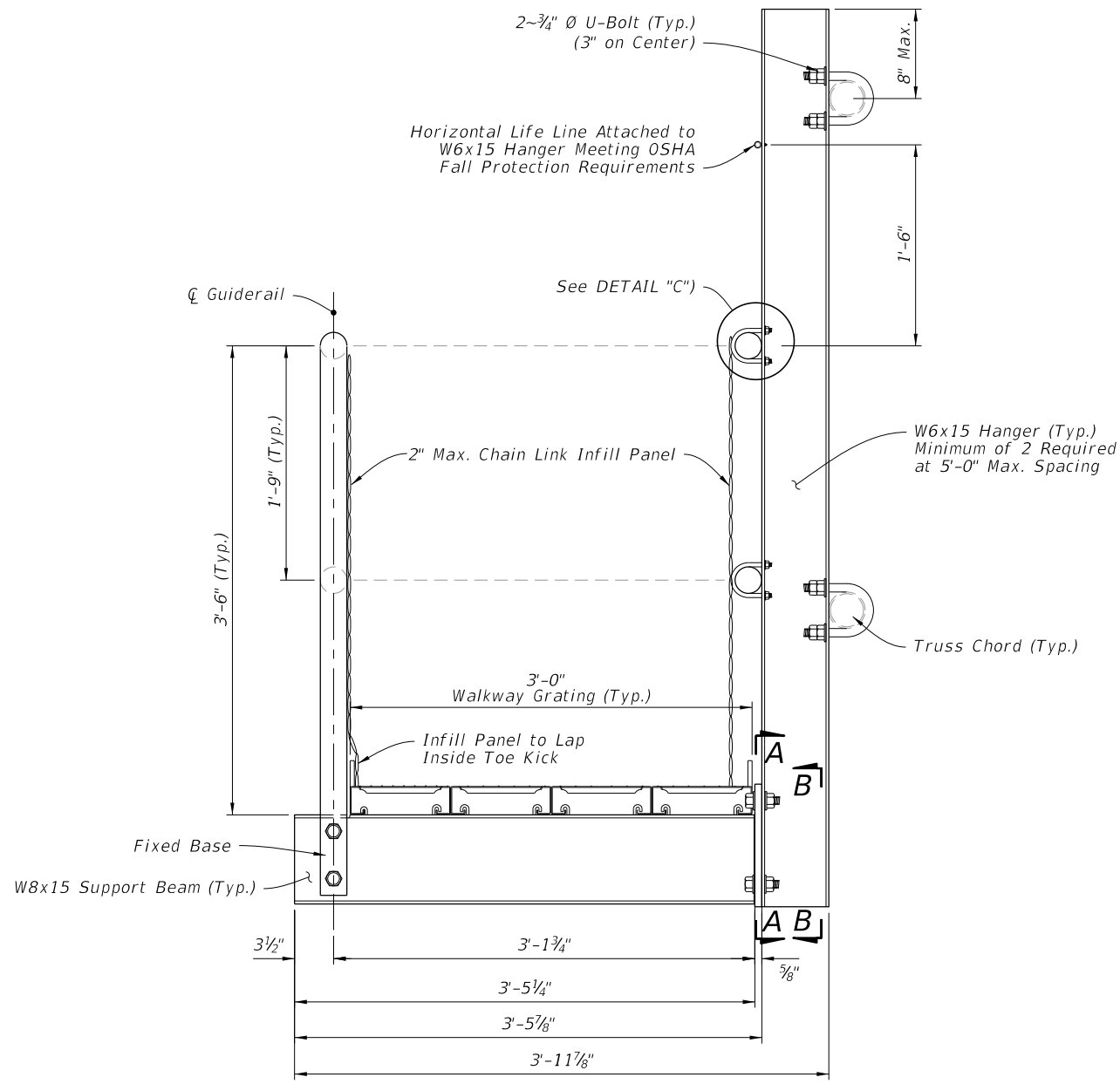
INDEX	SHEET
700-091	2 of 3

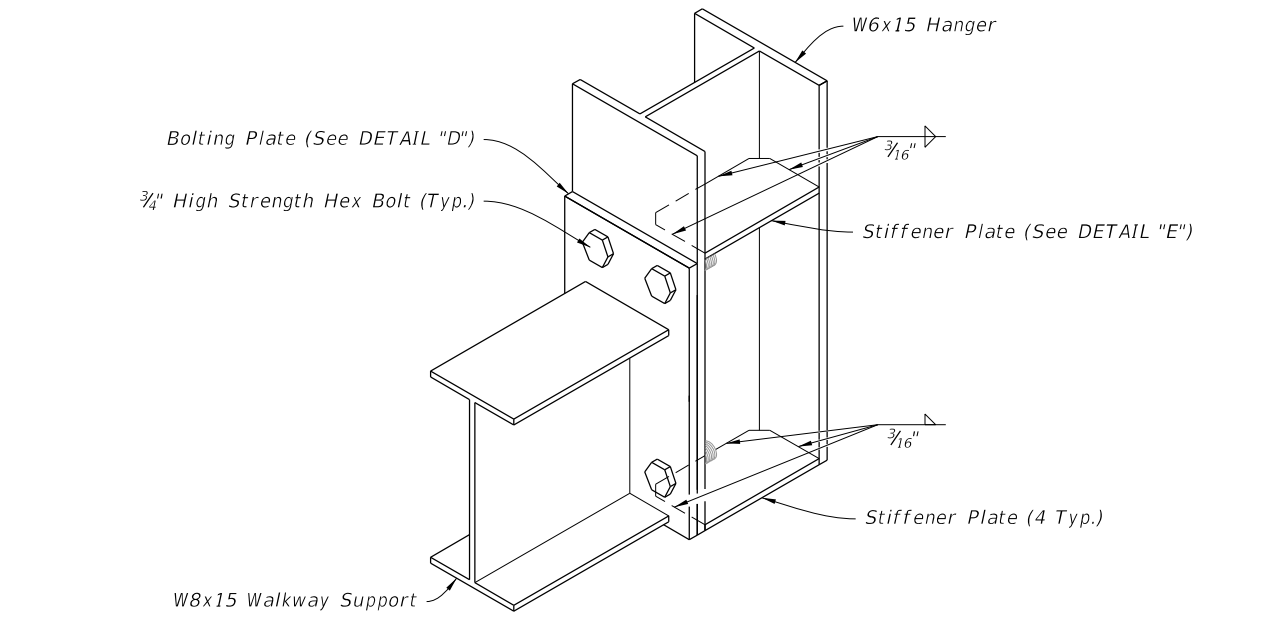

WALKWAY SUPPORT DETAILS



ISOMETRIC VIEW

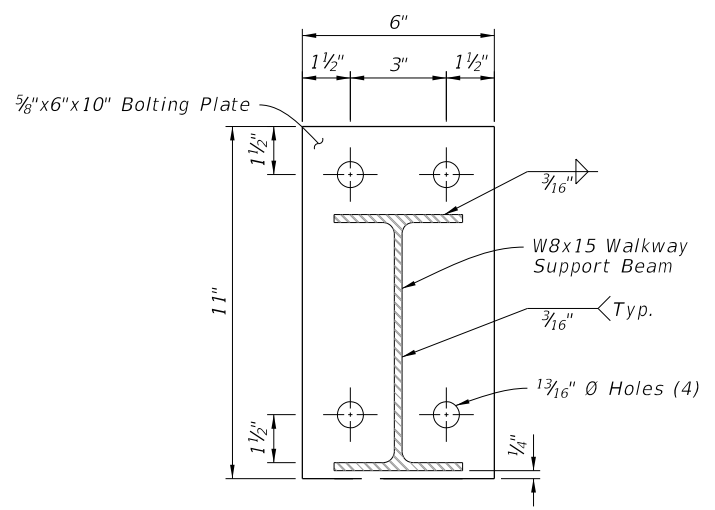

SECTION A-A

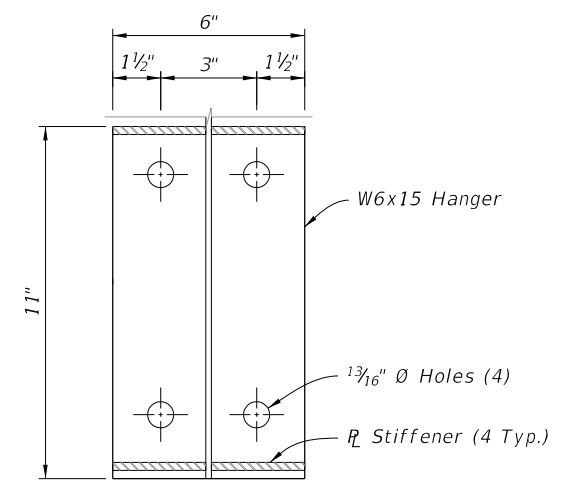

SECTION B-B

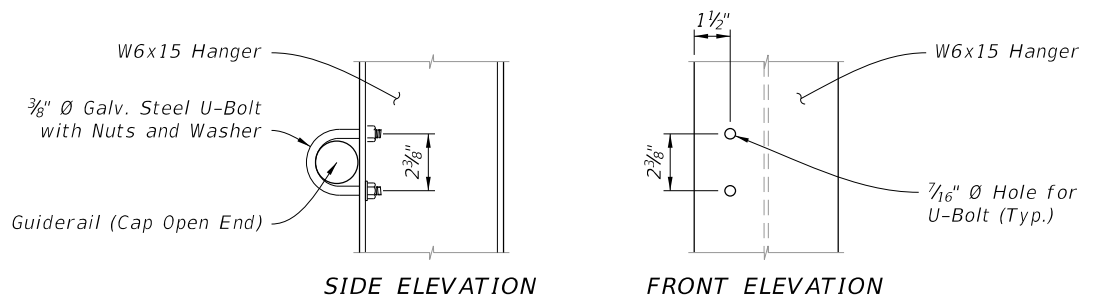

DETAIL "C"
(Guiderail Attachment)

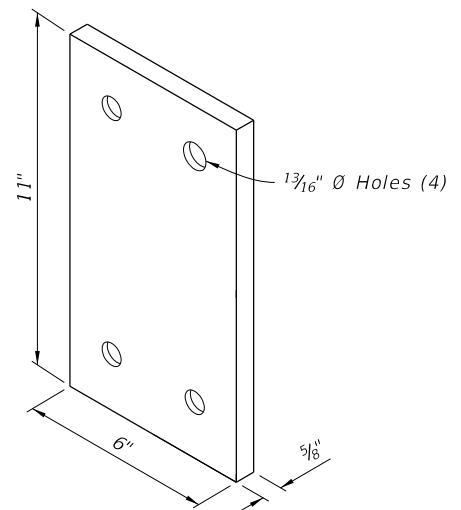

DETAIL "D"
(Bolting Plate)

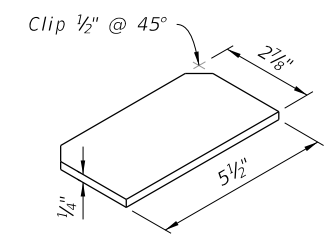

DETAIL "E"
(Stiffener Plate)

WALKWAY SUPPORT DETAILS

10/14/2019 2:41:07 PM

LAST REVISION 11/01/19	DESCRIPTION:	 FY 2020-21 STANDARD PLANS	CATWALK DETAILS	INDEX 700-091	SHEET 3 of 3
---------------------------	--------------	--	-----------------	------------------	-----------------