

FRONT ELEVATION

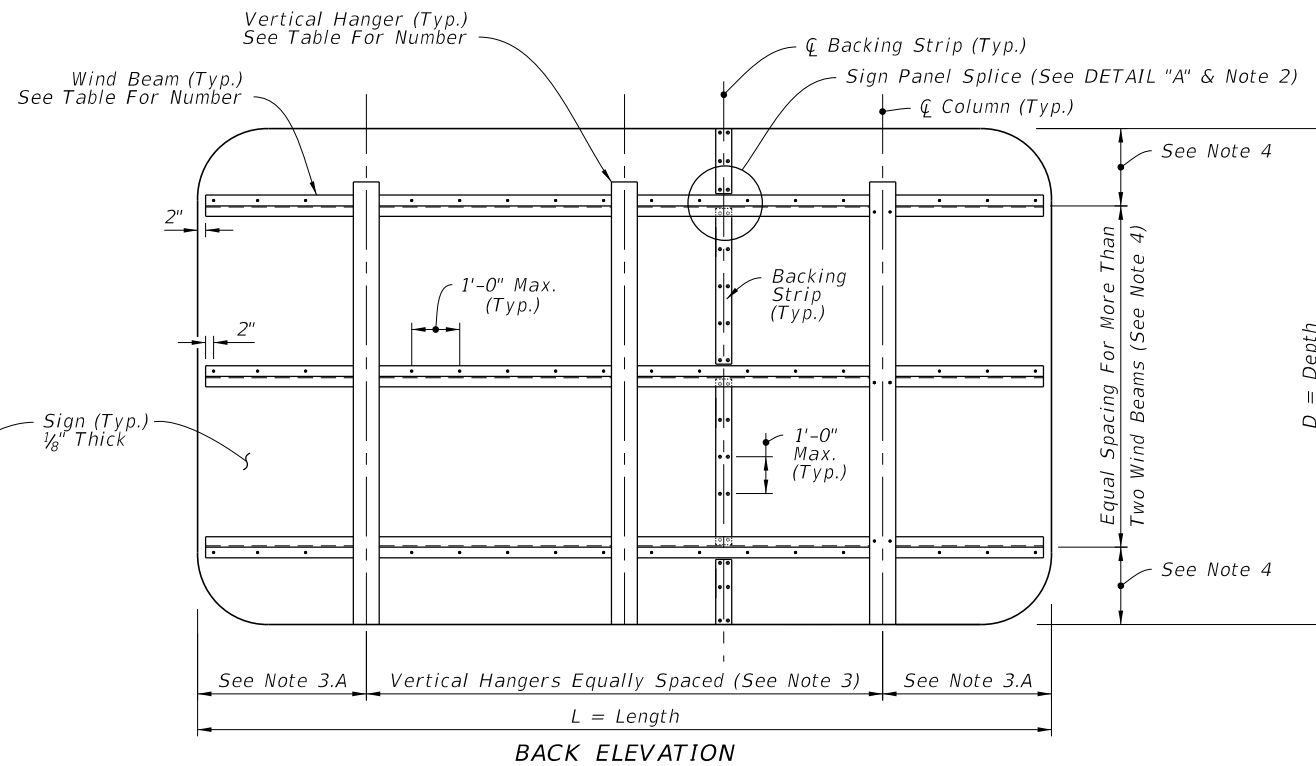

BACK ELEVATION

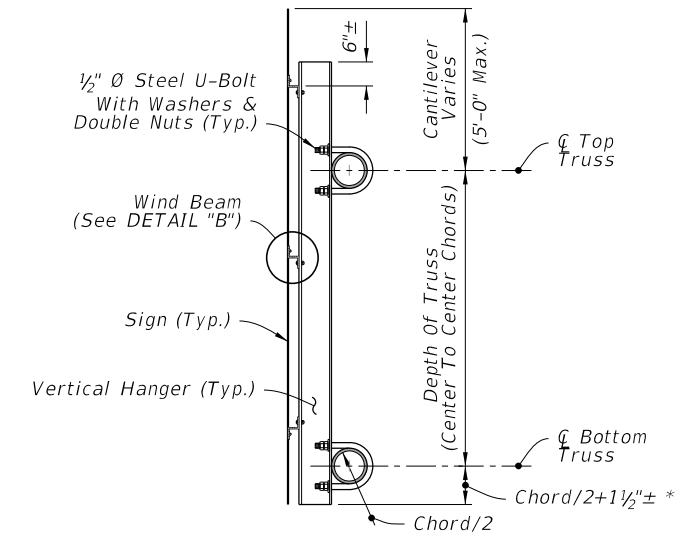

SIDE ELEVATION

TYPICAL SIGN FOR OVERHEAD TRUSS

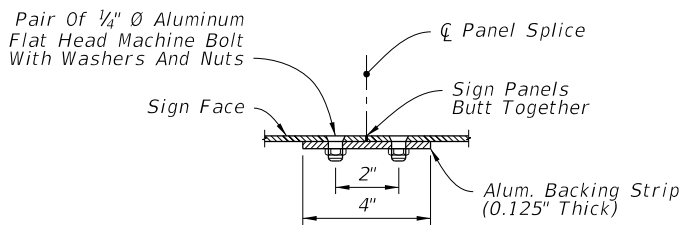

PLAN VIEW

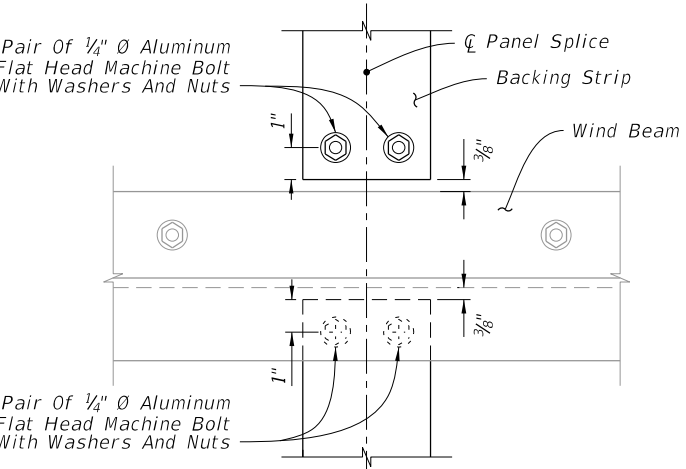

ELEVATION  
SIGN PANEL SPLICE

DETAIL "A"

**WIND BEAM TABLE (Z 3 x 2 1/16 x 2.33)**

Number of Horizontal Wind Beams Based on Sign Depth (D)

2 Beams	3 Beams	4 Beams	5 Beams	6 Beams
D ≤ 5'	5' < D ≤ 9'	9' < D ≤ 12'	12' < D ≤ 15'	15' < D ≤ 18'

**HANGER TABLE (I 6 x 4.69 or Z 5 x 3 1/4 x 6.19)**

Number of Vertical Hanger Beams Based on Wind Speed and Sign Length (L)

	2 Hangers	3 Hangers	4 Hangers	5 Hangers	6 Hangers
130 mph	L ≤ 20'	20' < L ≤ 30'	30' < L ≤ 40'	40' < L ≤ 50'	--
150 mph	L ≤ 18'	18' < L ≤ 27'	27' < L ≤ 35'	35' < L ≤ 45'	45' < L ≤ 50'
170 mph	L ≤ 15'	15' < L ≤ 20'	20' < L ≤ 28'	28' < L ≤ 35'	35' < L ≤ 43'

NOTE: For Monroe County designs, use 170 mph values but with Z 5 x 3-1/4 x 6.19 vertical hanger beams only.

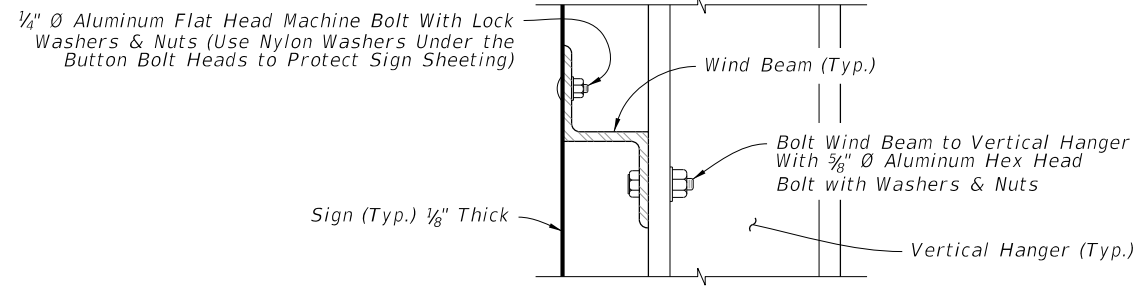

DETAIL "B"

GENERAL NOTES

- Work this Index with Index 700-040 and 700-041.
- The number and location of the Panel Splices are determined by the Sign Face supplier.
- Spacing of Vertical Hangers:
  - A. Two Vertical Hanger = 21.0% L
  - Three Vertical Hanger = 15.0% L
  - Four Vertical Hanger = 11.0% L
  - Five Vertical Hanger = 9.0% L
  - Six Vertical Hanger = 7.0% L
  - B. Spacing of vertical hangers may be varied slightly as necessary to clear the truss struts and diagonals at panel points
- Spacing of Wind Beams:
  - Two Wind Beams = 21.0% D
  - Three Wind Beams = 15.0% D
  - Four Wind Beams = 11.0% D
  - Five Wind Beams = 9.0% D
  - Six Wind Beams = 7.0% D
- Shop Drawings:
  - A. Required for Sign Panels deeper than 10'-0" with a horizontal panel splice.
  - B. Splice must be located in between interior Zee Supports and only allowed on signs greater than 10'-0".
- Materials:
  - A. Aluminum:
    - a. Bars, and Extruded Shapes: ASTM B 221, Alloy 6061-T6 or Alloy 6351-T5
    - b. Structural Shapes: ASTM B308, Alloy 6061-T6
    - c. Flat Head and Hex Head Machine Bolts: ASTM F468, Alloy 2024-T4
    - d. Hex Nuts: ASTM F467, Alloy 6061-T6 or Alloy 6262-T9
    - e. Washers: ASTM B221, Alclad 2024-T4
  - B. Steel:
    - a. U-Bolts: ASTM A449 or ASTM A193 B7
    - b. Nuts: ASTM A563, 2 per leg
    - c. Washers: ASTM F436, (Flat Washers)
- Coatings:
  - A. Aluminum Bolts, Nuts and Washers: Anodic (0.0002 inches min) and chromate sealed.
  - B. Galvanized Steel Bolts, Nuts and Washers: ASTM F2329
- Wind Speed by county: see Index 715-010.

10/14/2019 2:27:41 PM