

NOTES:

1. Work with Index 700-010.

2. Shop Drawings: Not required.

3. Materials:

- A. Steel Plate: ASTM A36 or ASTM A709 Grade 36
- B. Steel Pipe (Support Post): ASTM A501 Schedule 40
- C. Aluminum Pipe: ASTM B429 Alloy 6061-T6
- D. Galvanized U-Bolts, Nuts and Plate Washer
 - a. U-Bolts: ASTM A449
 - b. Hex Nuts: ASTM A 563 Lock Nuts
 - c. Plate Washer: ASTM A 36 or ASTM A709 Grade 36 or 50
- E. Galvanized Anchor bolts, Nuts and Washers:
 - a. Anchor Rod: ASTM F1554 Grade 55 fully threaded (for Adhesive Anchors)
 - b. Anchor Bolts: ASTM F1554 Grade 55 Grade A Hex
 - c. Nuts: ASTM A563 Heavy Hex Locking
 - d. Washers: ASTM F436
- F. Adhesive Anchor Bonding Material: Specification 931 Type HV Adhesive.
- G. Weld Material: E70XX
- H. Snap-In Post Cap: UV and weather-resistant glass-filled polyester cap

4. Coating:

- A. U-Bolts, Threaded Rods, Nuts and Washers: ASTM F2329
- B. Other Steel: ASTM A123

5. Fabrication:

- A. Weld: Specification 460-6.4
- B. Hot dip galvanize after fabrication

6. Construction:

- A. Locate Sign Support a minimum of 5 feet from an open joint or transition (sign stationing may be adjusted to accommodate this requirement).
- B. Base plate must be flush with back of Traffic Railing
- C. Anchors in Traffic Railings:
 - a. Install Adhesive Anchors in accordance with Specification 416 except perform field test on one anchor per sign support location.
 - b. Use templates and tie anchors as necessary to maintain correct placement of C-I-P Embedded Anchors
 - c. Do not drill into existing conduit
- D. Temporary Signs on Permanent Traffic Railings: Same as Permanent except Field testing of anchors is not required

7. Removal of Temporary Signs on Permanent Traffic Railings:

- A. Cut anchor rods flush with the top of the traffic railing
- B. Coat anchors with Type F-1 epoxy to prevent corrosion
 - a. Extend coating 2 inches beyond edge of cut anchor rods
 - b. Epoxy coating 1/16" thick minimum

8. Payment:

Include the cost of all materials and labor in the cost of the single post sign assembly.

SIGN LIMITATIONS TABLE	
MAX. SIGN AREA (SF)	MAX. SIGN CENTROID HEIGHT (DIM. A + DIM. C)
25	9'-7"

Dimension A = Distance from centerline of the Support Post to the bottom of the sign or sign cluster.

Dimension C = Vertical distance from the bottom of the sign or sign cluster to the Centroid of the sign or sign cluster.

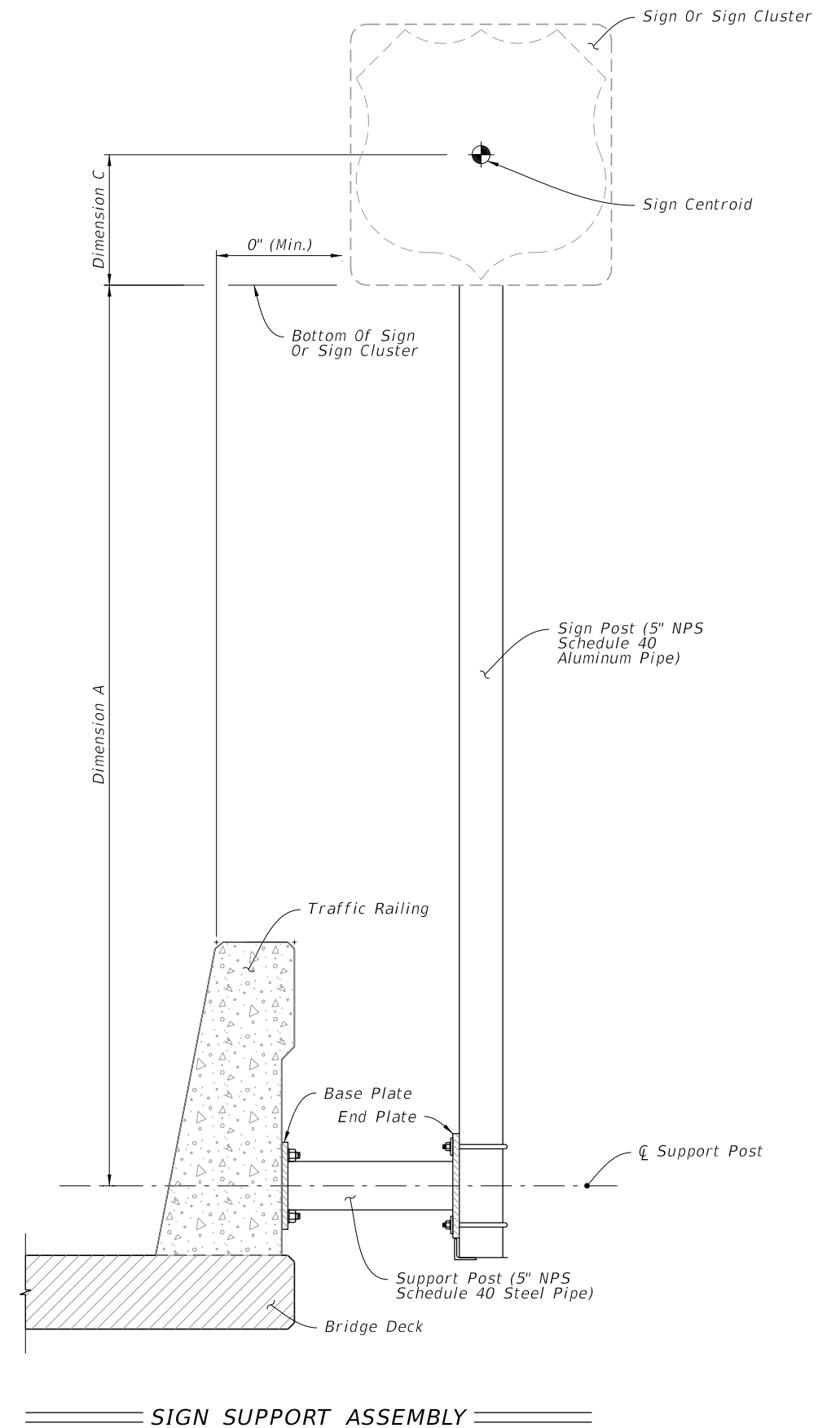

10/14/2019 2:26:23 PM

LAST REVISION 11/01/18	REVISION	DESCRIPTION:		FY 2020-21 STANDARD PLANS	SINGLE POST BRIDGE MOUNTED SIGN SUPPORT	INDEX 700-012	SHEET 1 of 3
---------------------------	----------	--------------	--	------------------------------	---	------------------	-----------------

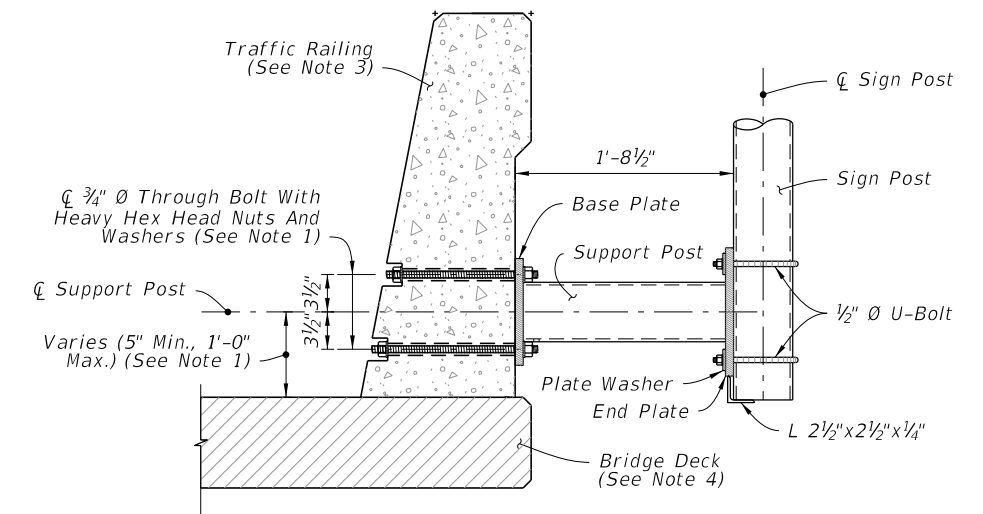
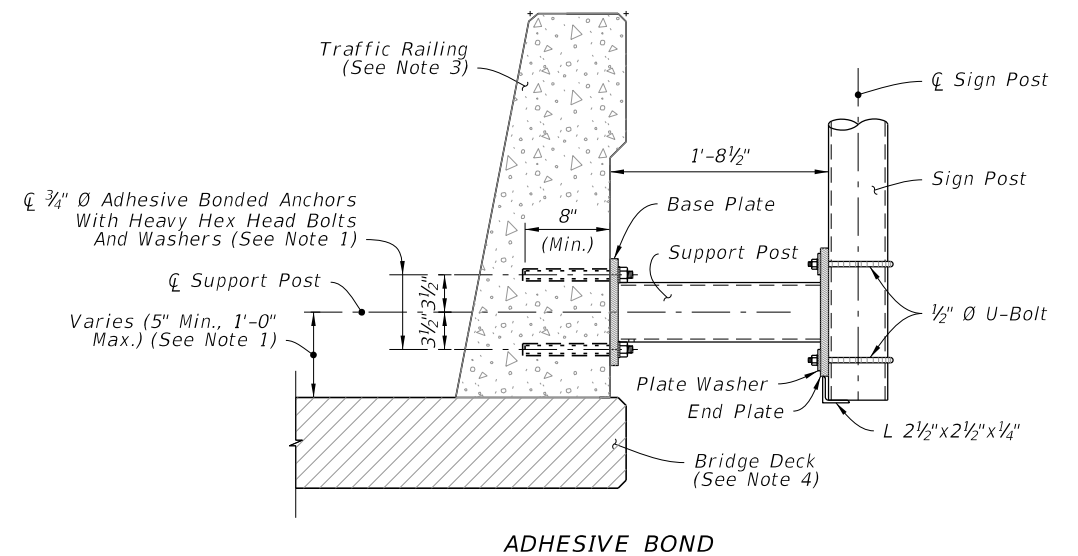
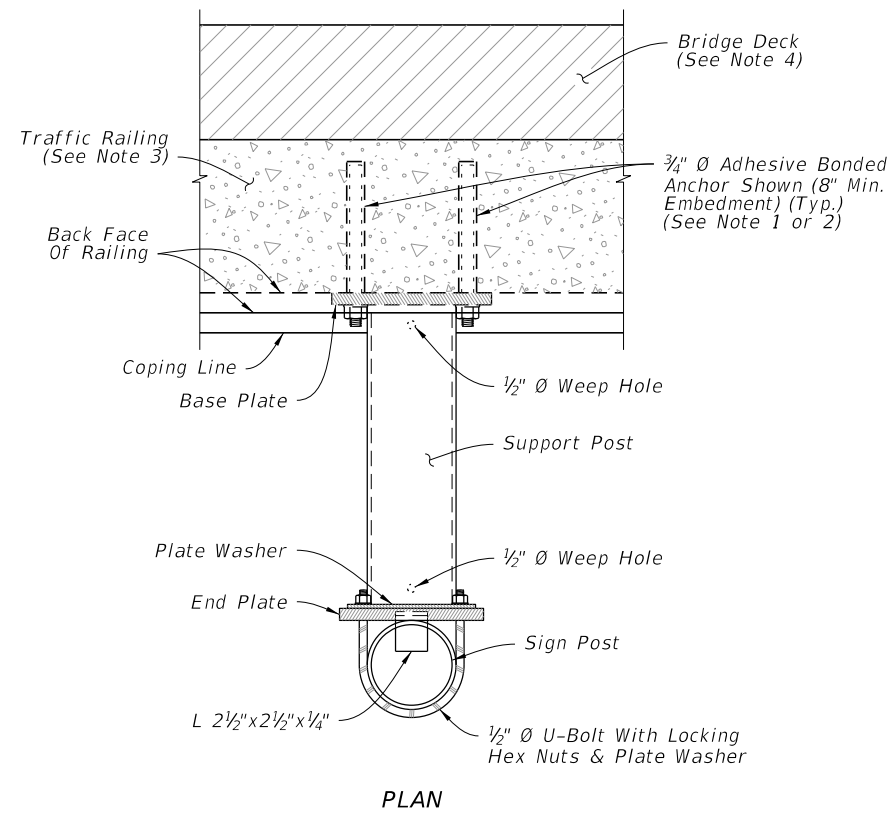
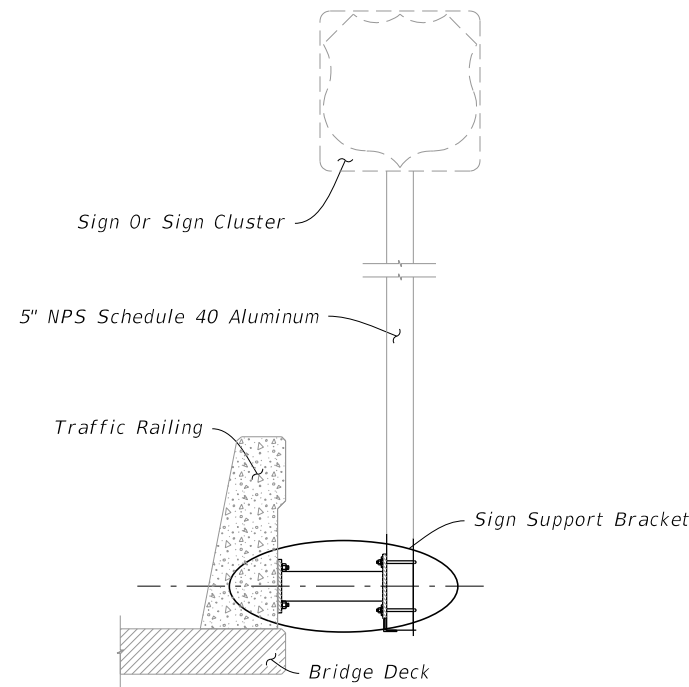

TYPICAL SECTION - EXISTING RAILING

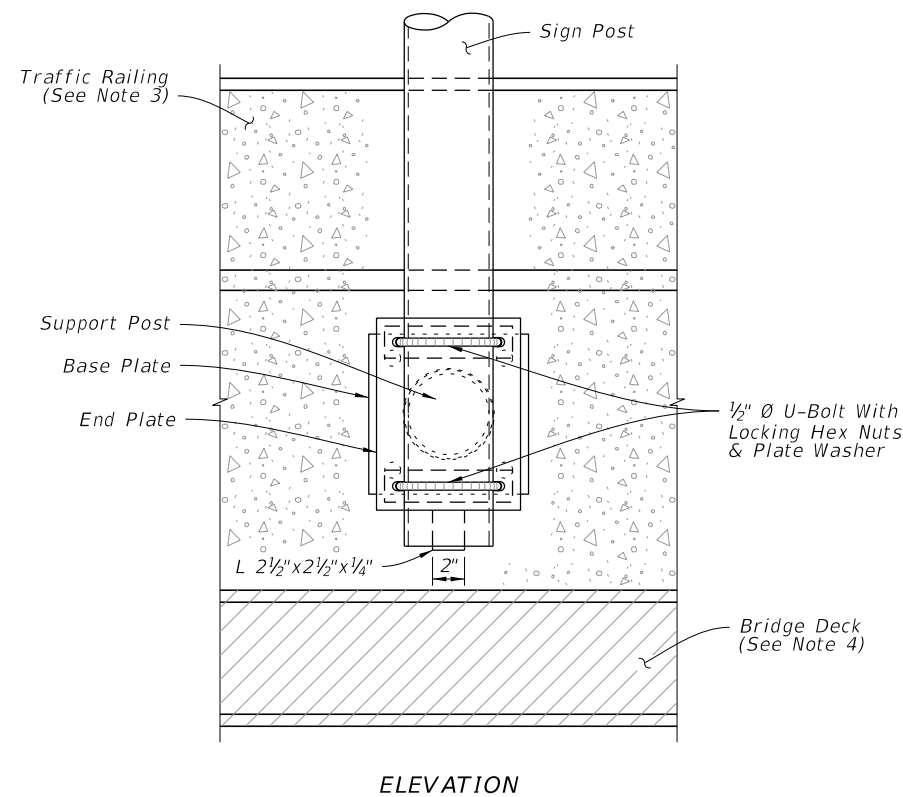
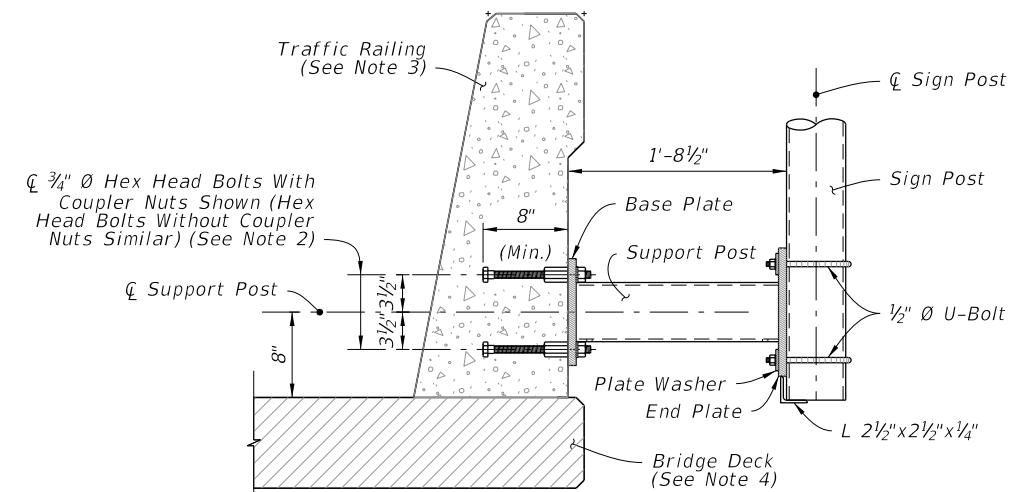

SIGN SUPPORT BRACKET

NOTES:

1. Existing Traffic Railings:

A. Locate existing conduit prior to drilling and adjust placement of base plate as necessary to avoid damaging existing conduit. Base plate must be flush with back of traffic railing. Maintain a minimum cover 2" from face of traffic railing to tip of Adhesive Anchor.

B. For concrete parapets less than 10" thick, through bolt 3/4" Ø Heavy Hex Head Bolts with Nuts and Washers in lieu of Adhesive Bonded Anchors. Bolt heads shall not protrude more than 1 1/2" beyond traffic face of railing.

C. For through bolting, countersink the nut and washer so that the bolt and nut does not extend beyond the face of the traffic railing. Do not exceed a countersink depth and diameter of 2 1/2".

2. New Traffic Railings:

A. Optional Couplers are shown for slipforming; keep Anchor Bolt coupler threads free of concrete.

3. 36" Single-Slope Traffic Railing shown, other Traffic Railings and Parapets are similar.

4. Bridge Deck shown, Approach Slab and Retaining Wall are similar.

10/14/2019 2:26:24 PM

LAST REVISION	DESCRIPTION:
11/01/17	



FY 2020-21
STANDARD PLANS

SINGLE POST BRIDGE MOUNTED SIGN SUPPORT

INDEX
700-012

SHEET
2 of 3

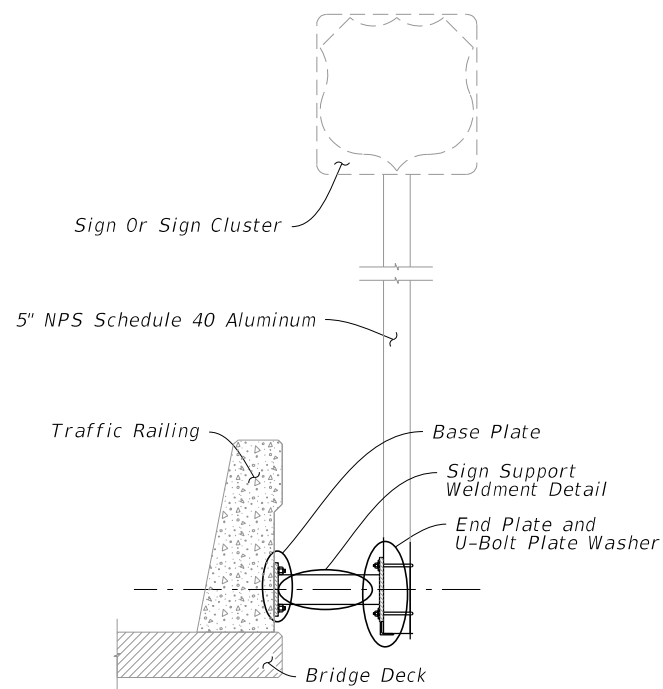

SIGN SUPPORT ASSEMBLY

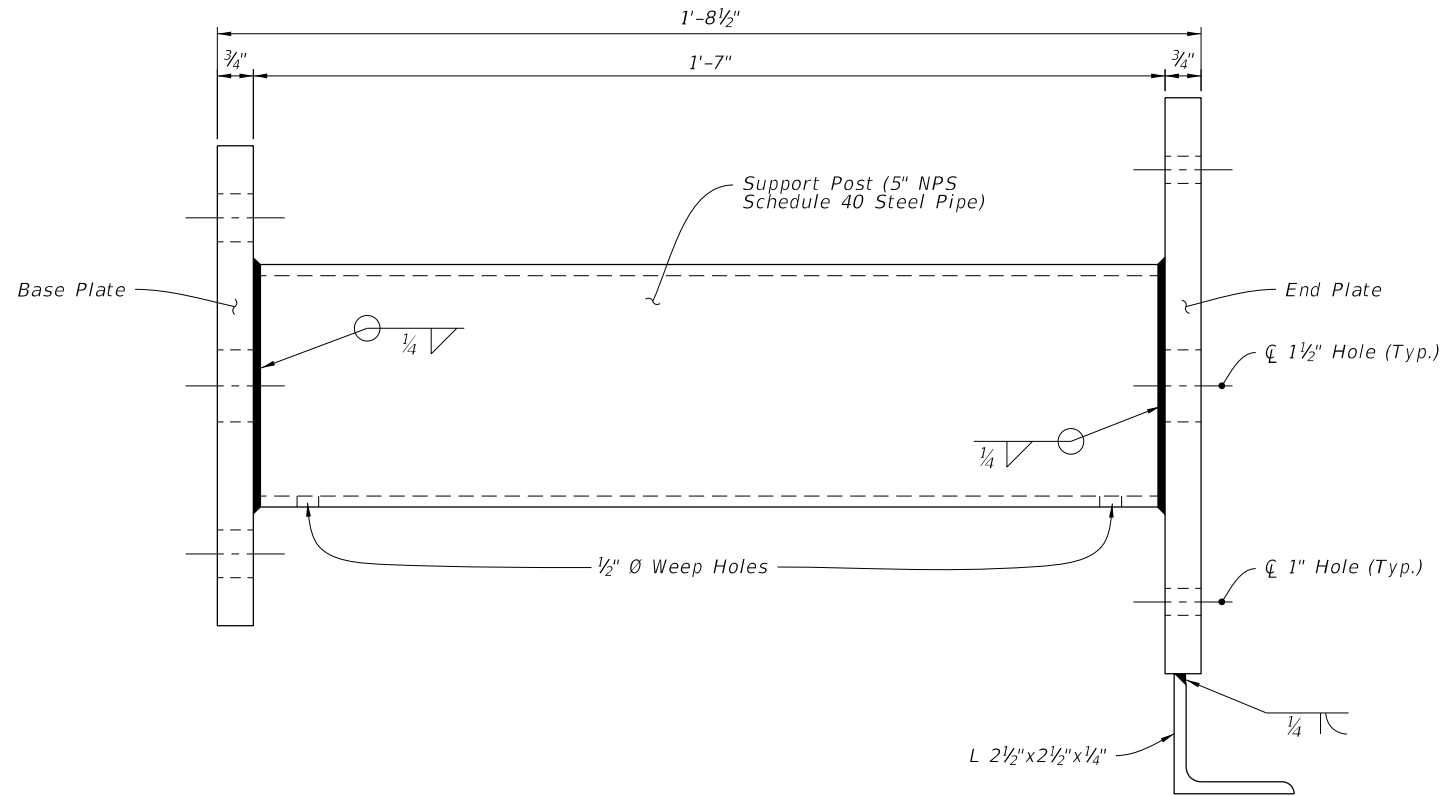

SIGN SUPPORT WELDMENT DETAIL

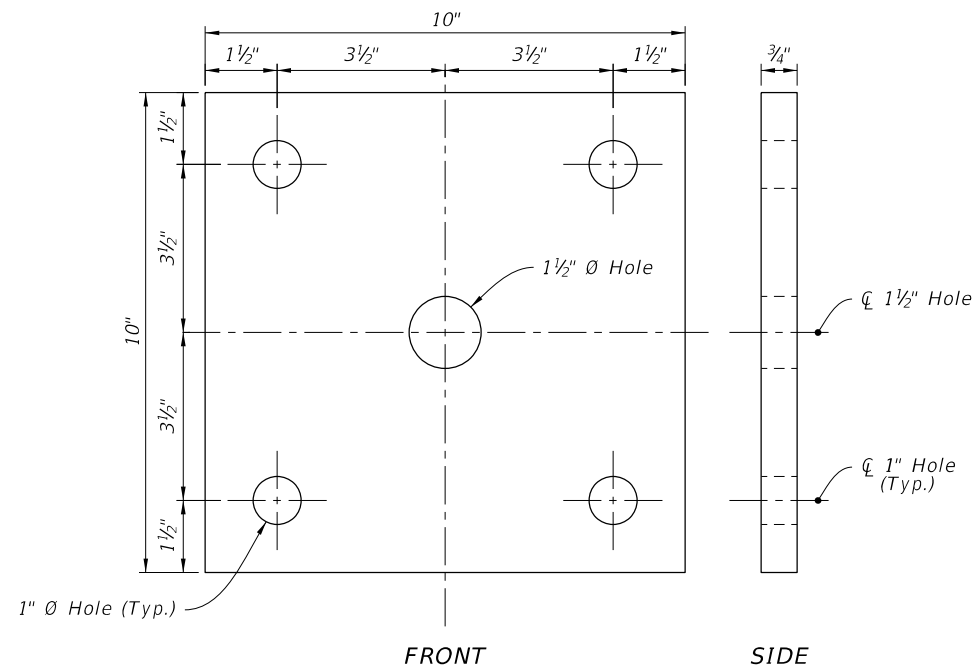

BASE PLATE

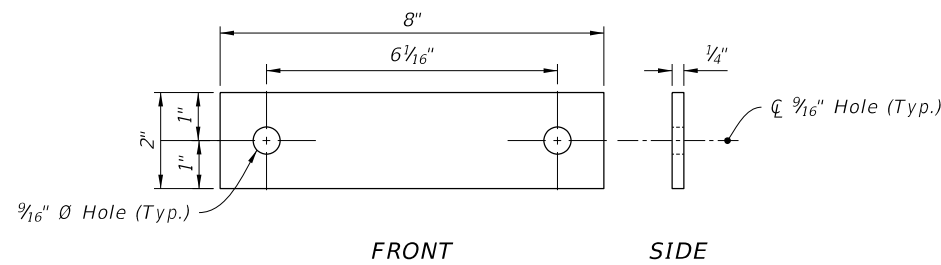

U-BOLT PLATE WASHER

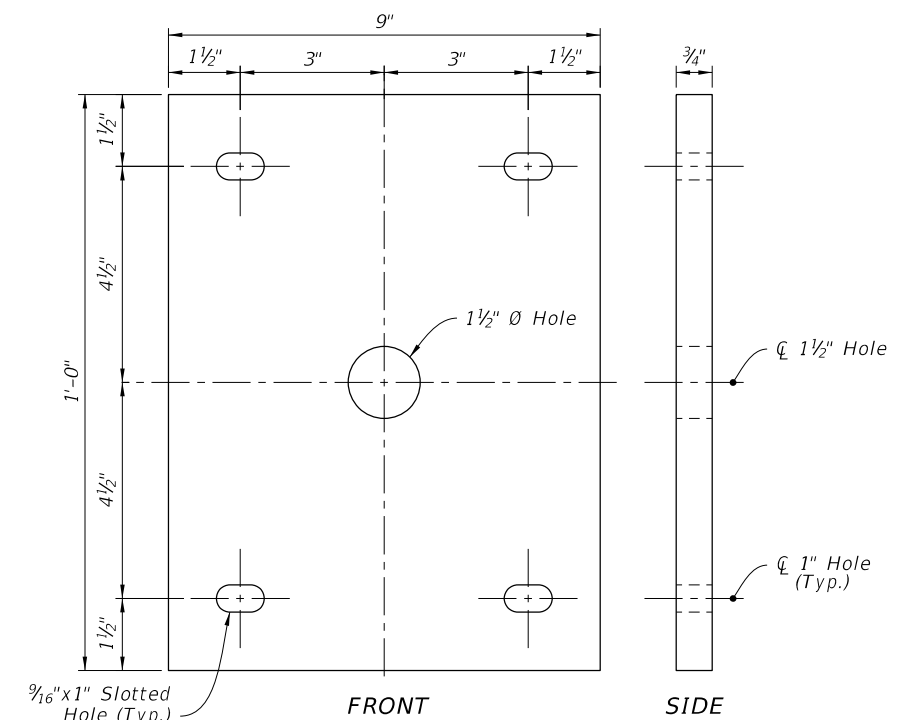

END PLATE

10/14/2019 2:26:25 PM

LAST REVISION 11/01/17	REVISION	DESCRIPTION:
---------------------------	----------	--------------



FY 2020-21
STANDARD PLANS

SINGLE POST BRIDGE MOUNTED SIGN SUPPORT

INDEX
700-012

SHEET
3 of 3