

**GENERAL NOTES:**

1. Cross Slopes and Grades:

- A. Sidewalk, ramp, and landing slopes (i.e. 0.02, 0.05, and 1:12) shown in this Index are maximums. With approval of the Engineer, provide the minimum feasible slope where the requirements cannot be met.
- B. Landings must have cross-slopes less than or equal to 0.02 in any direction.
- C. Maintain a single longitudinal slope along each side of the curb ramp. Ramp slopes are not required to exceed 15 feet in length.
- D. Joints permitted at the location of Slope Breaks. Otherwise locate joints in accordance with Index 522-001. No joints are permitted within the ramp portion of the Curb Ramp.

2. Curb, Curb and Gutter and/or Sidewalk:

- A. Refer to Index 522-001 for concrete thickness and sidewalk details.
- B. Remove any existing curb, curb and gutter, or sidewalk to the nearest joint beyond the curb transition or to the extent that no remaining section is less than 5 feet long.

3. Curb Ramp Alpha-Identification:

- A. Sidewalk curb ramp alpha-identifications (e.g. CR-A) are provided for reference purposes in the Plans.
- B. Alpha-identifications CR-I and CR-J are intentionally omitted.

4. Detectable Warnings:

- A. Install detectable warnings in accordance with Specification 527.
- B. Place detectable warnings across the full width of the ramp or landing, to a minimum depth of 2 feet measured perpendicular to the curb line and no greater than 5 feet from the back of the curb or edge of pavement.
- C. If detectable warnings are shown in the Plans on slopes greater than 5%, align the truncated domes with the centerline of the ramp; otherwise, the truncated domes are not required to be aligned.

5. Detectable Warnings - Acceptance Criteria:

- A. Color and texture shall be complete and uniform.
- B. 90% of individual truncated domes shall be in accordance with the Americans with Disabilities Act Standards for Transportation Facilities, Section 705.
- C. There shall be no more than 4 non-compliant domes in any one square foot.
- D. Non-compliant domes shall not be adjacent to other non-compliant domes.
- E. Surfaces shall not deviate more than 0.10" from a true plane.

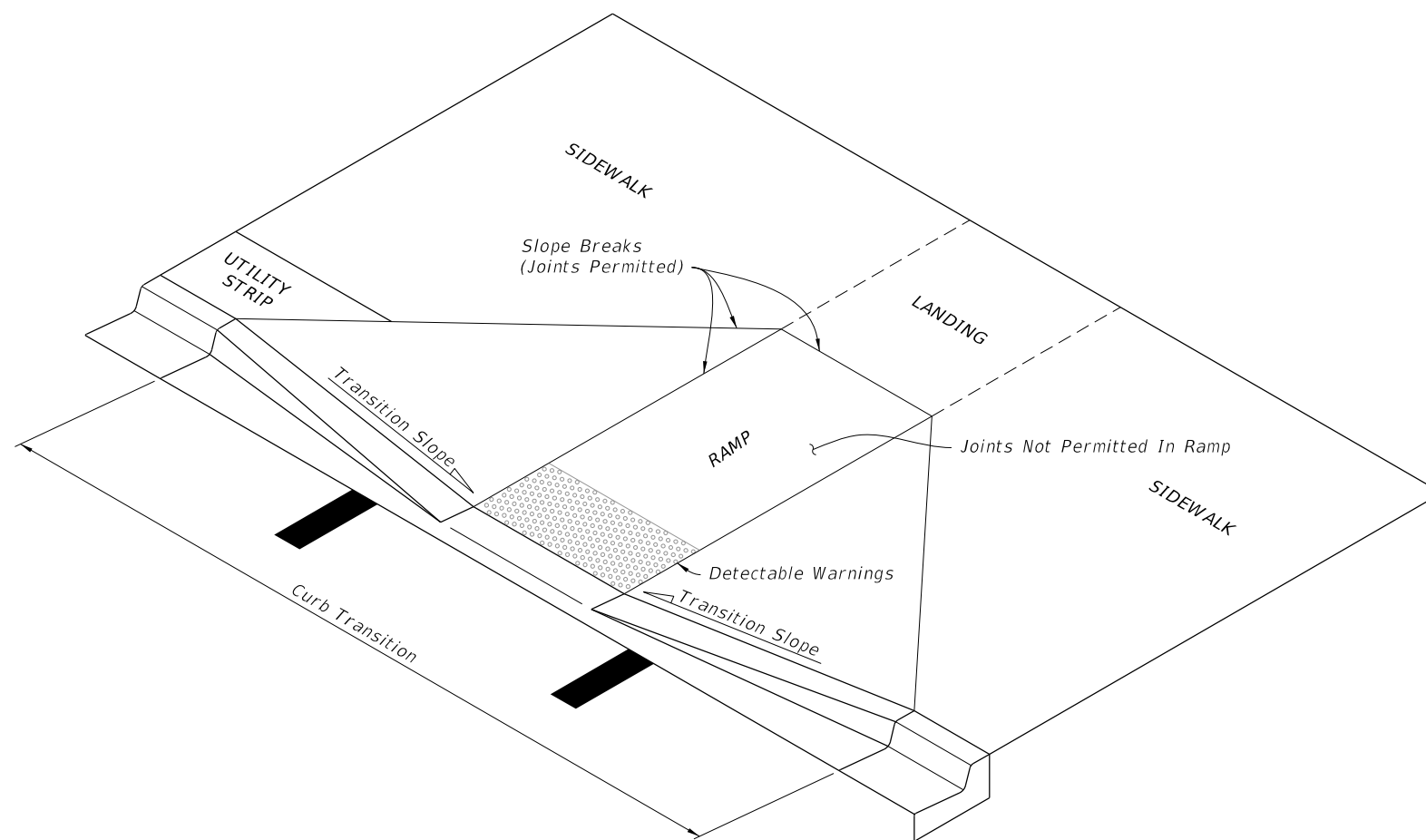

==== CURB RAMP NOMENCLATURE ====

7/20/2020 2:09:54 PM

LAST REVISION 11/01/19	REVISION	DESCRIPTION:	 FY 2020-21 STANDARD PLANS	DETECTABLE WARNINGS AND SIDEWALK CURB RAMPS	INDEX 522-002	SHEET 1 of 7
------------------------------	----------	--------------	--	---	------------------	-----------------

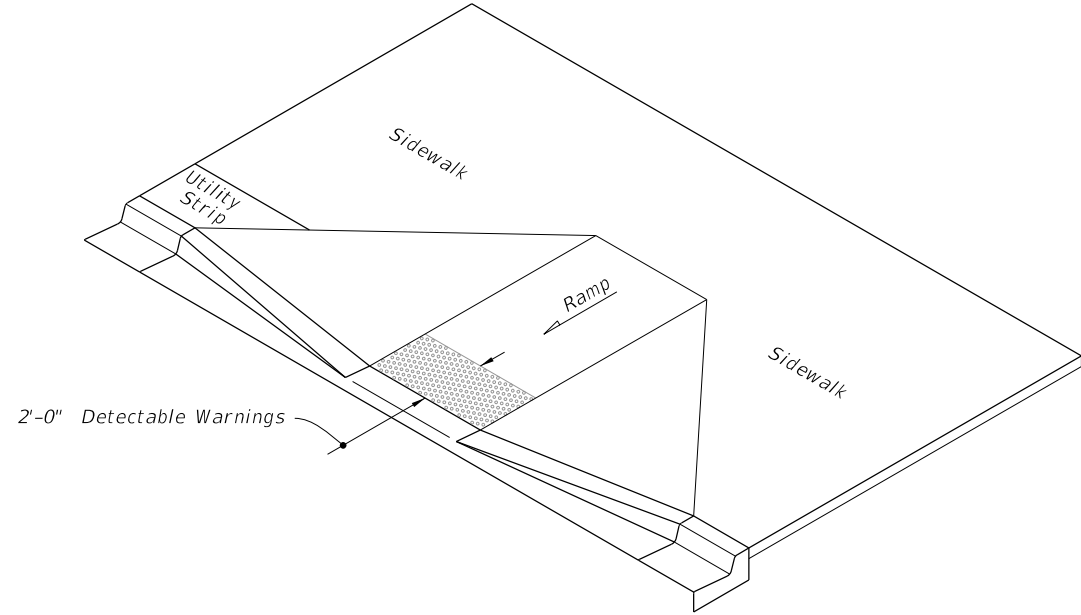

ISOMETRIC VIEW

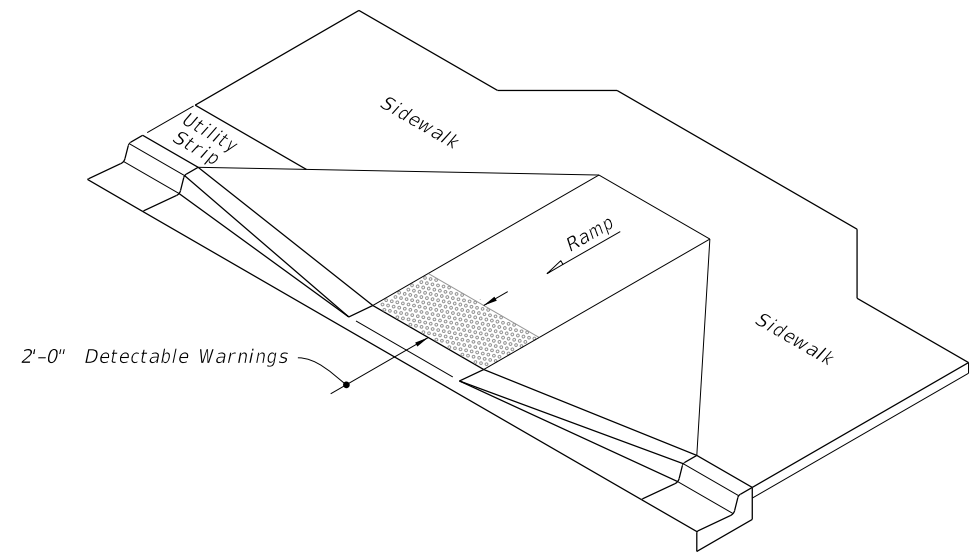

ISOMETRIC VIEW

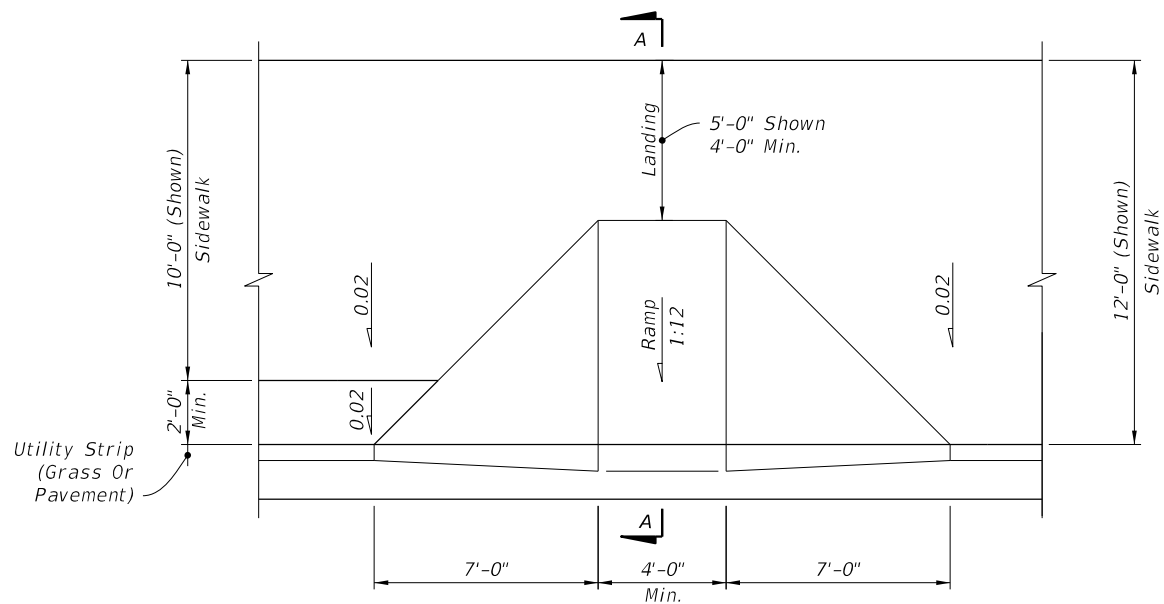

PLAN VIEW

NOTE: For Example of CR-A used in Radial Curb Returns, See Sheet 8.

CR-A

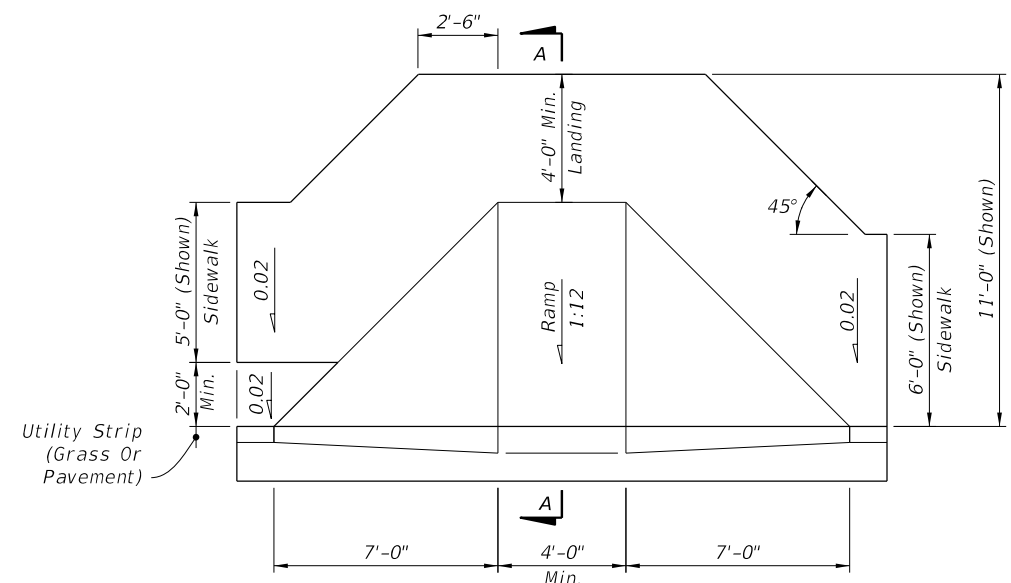

PLAN VIEW

CR-B

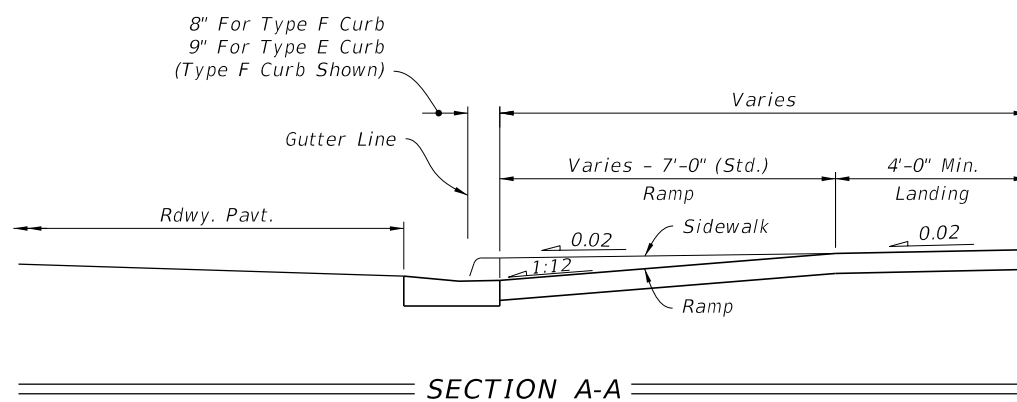

SECTION A-A

SIDEWALK CURB RAMPS CR-A AND CR-B

7/20/2020 2:09:58 PM

LAST REVISION 11/01/18	DESCRIPTION:
---------------------------	--------------

**FY 2020-21  
STANDARD PLANS**

DETECTABLE WARNINGS AND SIDEWALK CURB RAMPS

INDEX 522-002	SHEET 2 of 7
------------------	-----------------

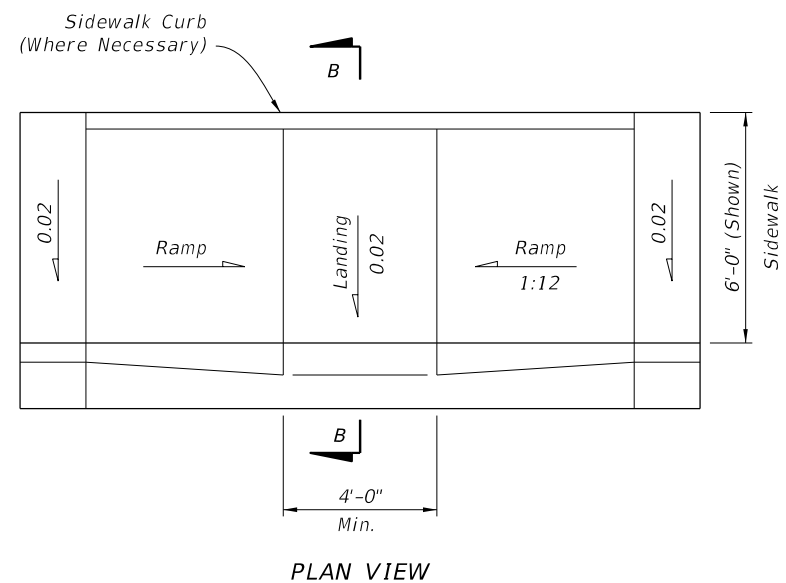

PLAN VIEW

CR-C

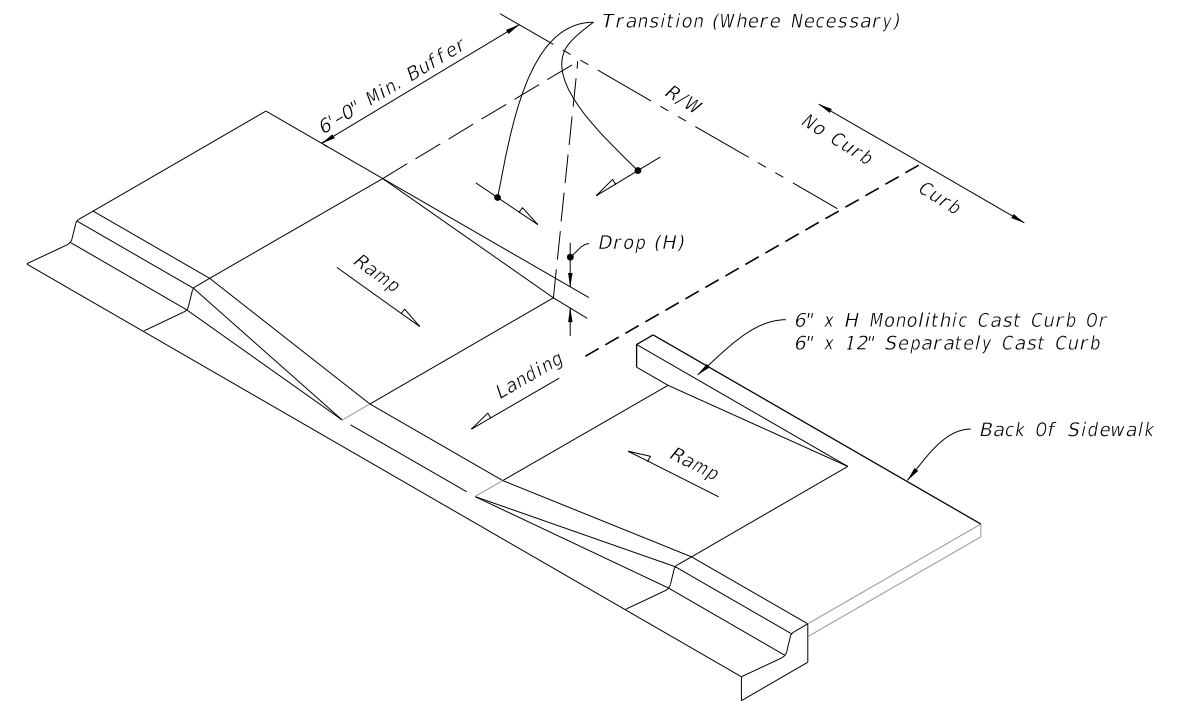

CONSTRUCTION OF SIDEWALK CURB IN CUT SECTIONS

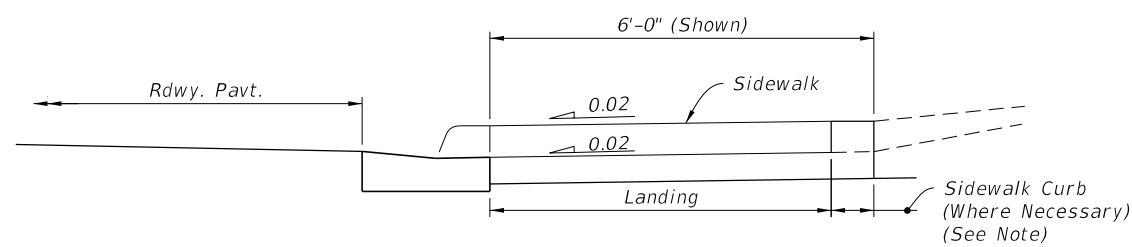

SECTION B-B

NOTE: For additional information on sidewalk curb construction, see SIDEWALK CURB OPTIONS details.

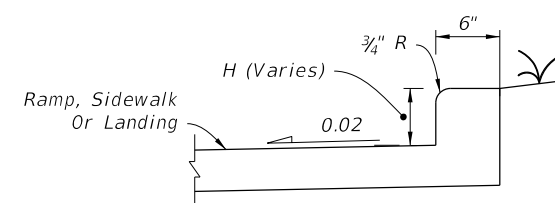

MONOLITHIC CAST CURB

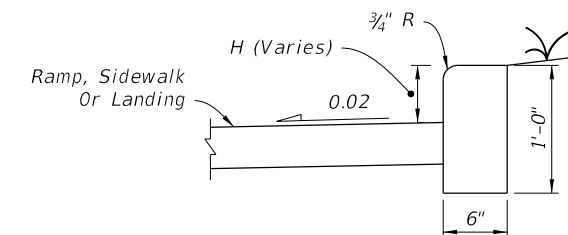

SEPARATELY CAST CURB

SIDEWALK CURB OPTIONS

SIDEWALK CURB RAMPS CR-C AND SIDEWALK CURB

7/20/2020 2:10:03 PM

LAST REVISION 11/01/18	DESCRIPTION:
---------------------------	--------------



FY 2020-21  
STANDARD PLANS

DETECTABLE WARNINGS AND SIDEWALK CURB RAMPS

INDEX  
522-002

SHEET  
3 of 7

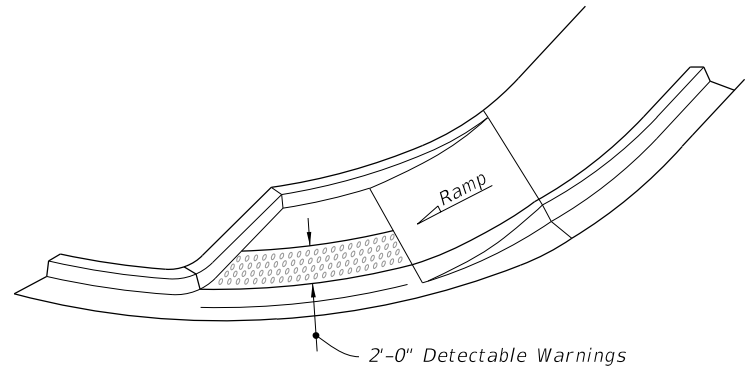

ISOMETRIC VIEW

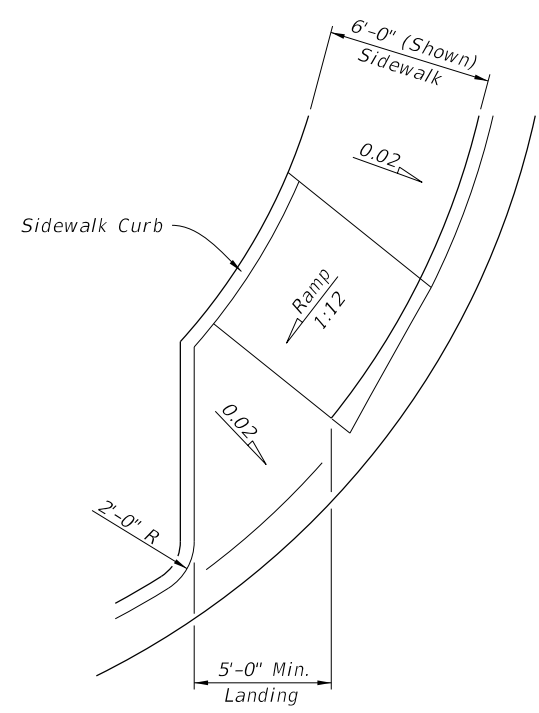

PLAN VIEW

CR-D

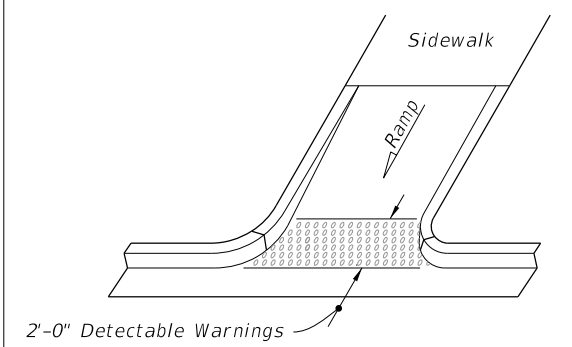

OPTION A

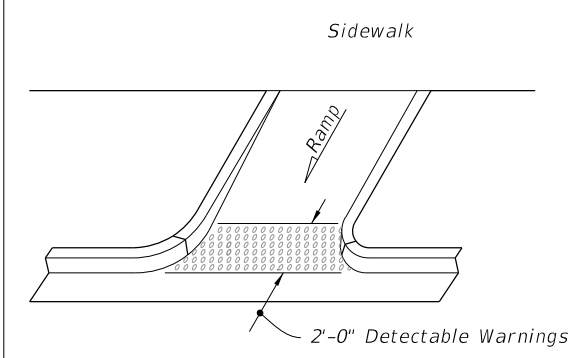

OPTION B  
ISOMETRIC VIEW

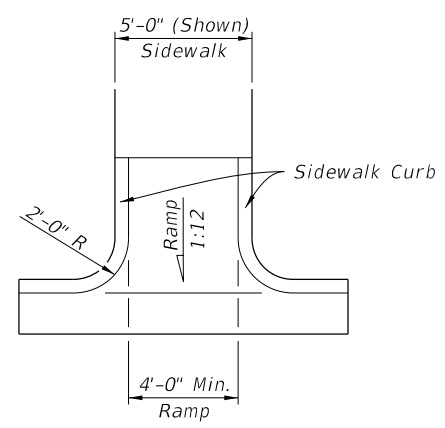

PLAN VIEW

CR-E

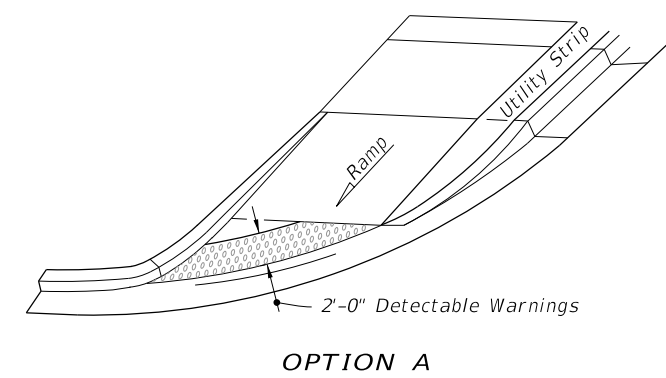

OPTION A

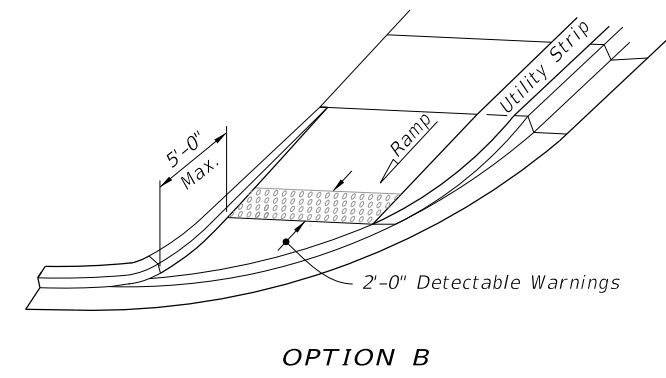

OPTION B  
ISOMETRIC VIEW

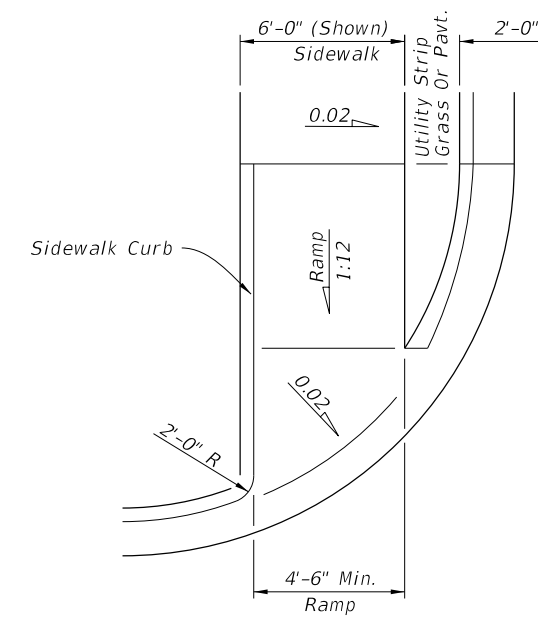

PLAN VIEW

CR-F

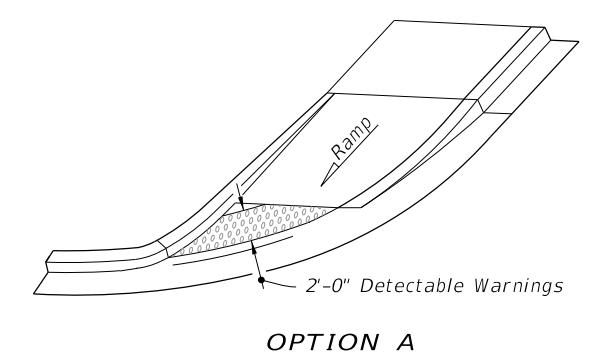

OPTION A

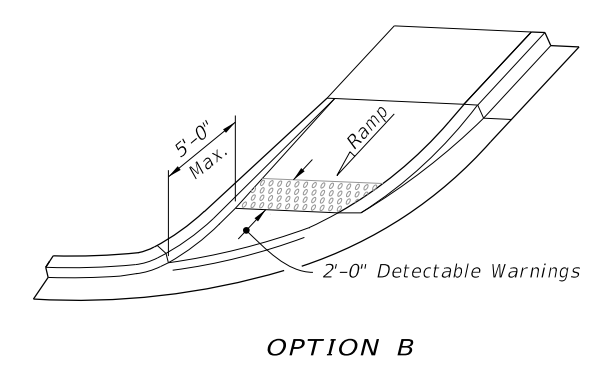

OPTION B  
ISOMETRIC VIEW

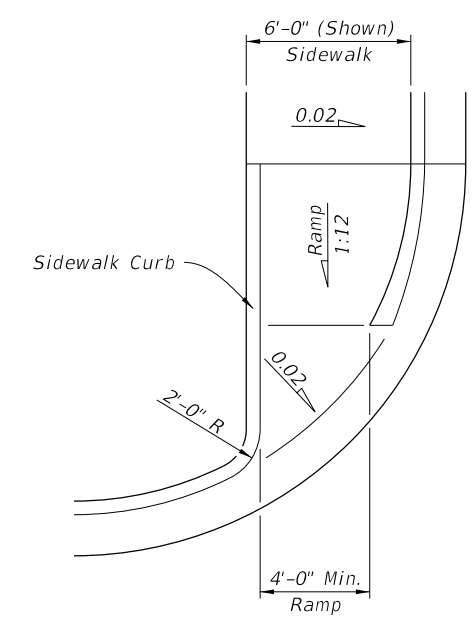

PLAN VIEW

CR-G

SIDEWALK CURB RAMPS CR-D, CR-E, CR-F & CR-G

7/20/2020 2:10:05 PM

LAST REVISION 11/01/18	DESCRIPTION:
---------------------------	--------------



**FY 2020-21  
STANDARD PLANS**

DETECTABLE WARNINGS AND SIDEWALK CURB RAMPS

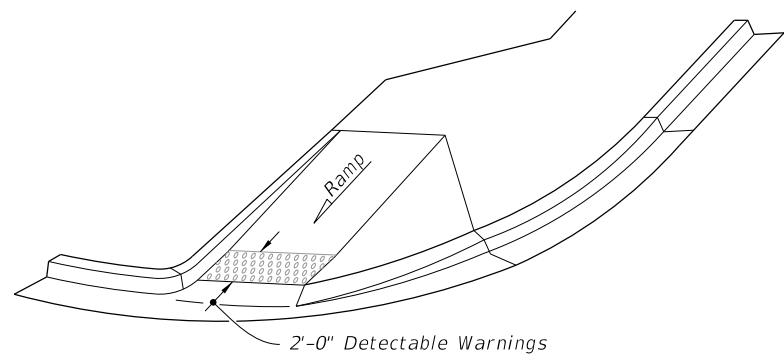
INDEX 522-002	SHEET 4 of 7
------------------	-----------------

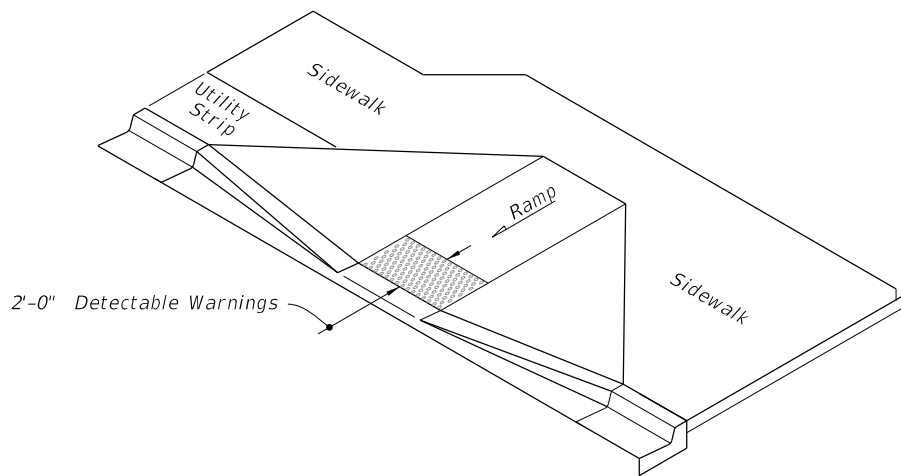

ISOMETRIC VIEW



ISOMETRIC VIEW

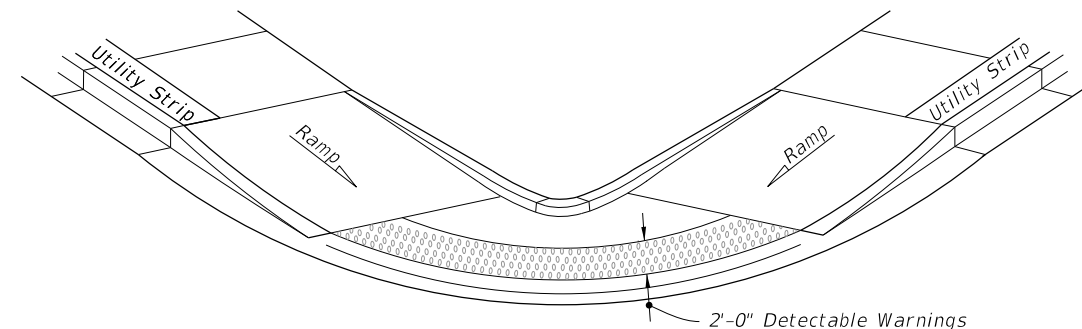

OPTION A

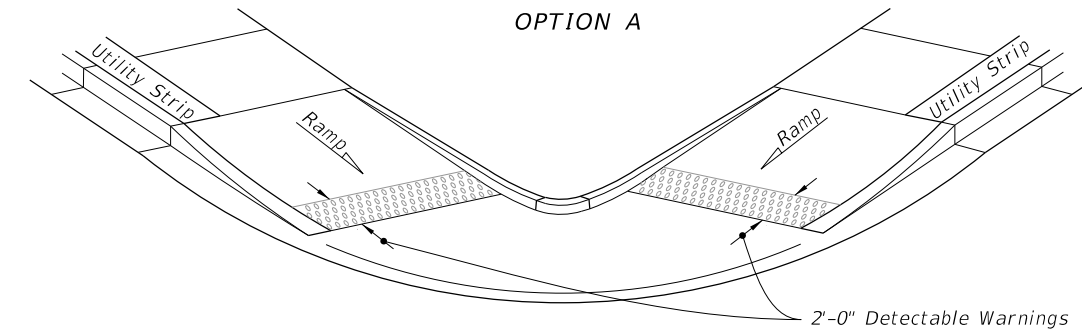

OPTION B

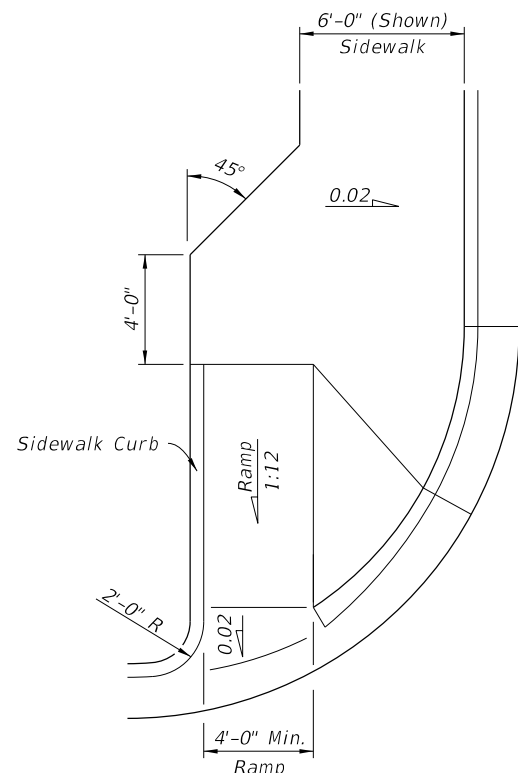

PLAN VIEW

CR-H

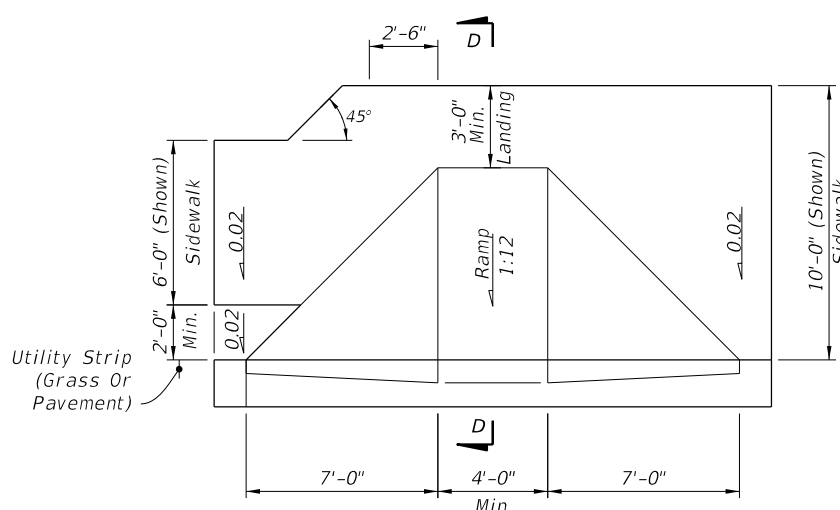

PLAN VIEW

CR-K

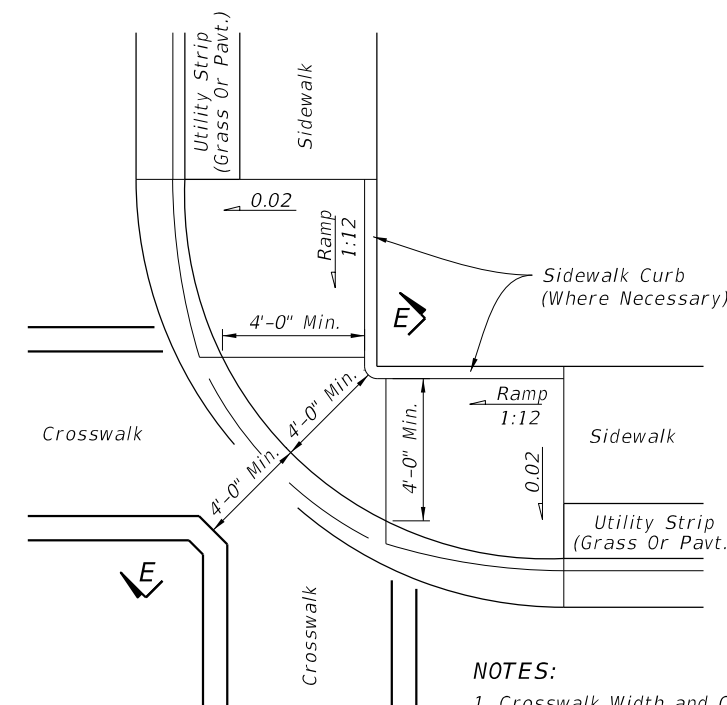

PLAN VIEW

CR-L

- NOTES:
1. Crosswalk Width and Configuration Vary; Must Conform to Index 711-001.
  2. 15' Radius Curve Shown for CR-L.
  3. For additional information on sidewalk curb construction, see SIDEWALK CURB OPTIONS details, on Sheet 3.

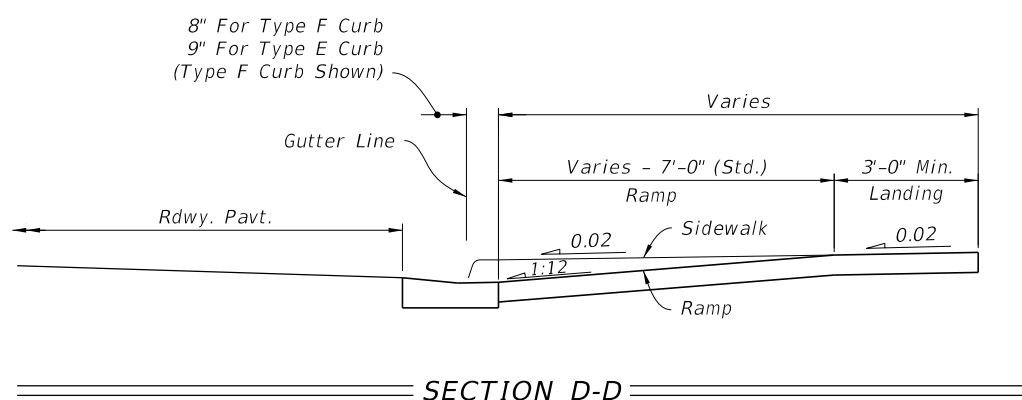

SECTION D-D

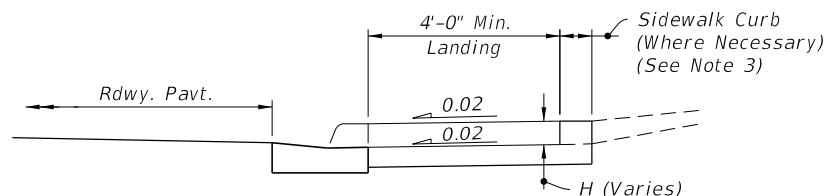

SECTION E-E

7/20/2020 2:10:08 PM

LAST REVISION 11/01/18	DESCRIPTION:
---------------------------	--------------

FDOT  
FY 2020-21  
STANDARD PLANS

DETECTABLE WARNINGS AND SIDEWALK CURB RAMPS

INDEX 522-002	SHEET 5 of 7
------------------	-----------------

SIDEWALK CURB RAMPS CR-H, CR-K & CR-L

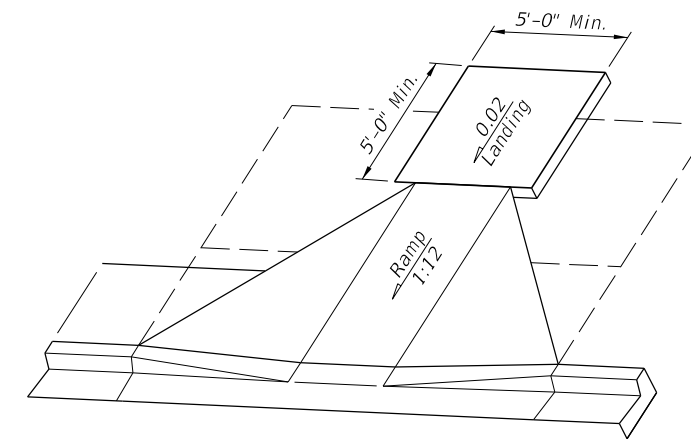
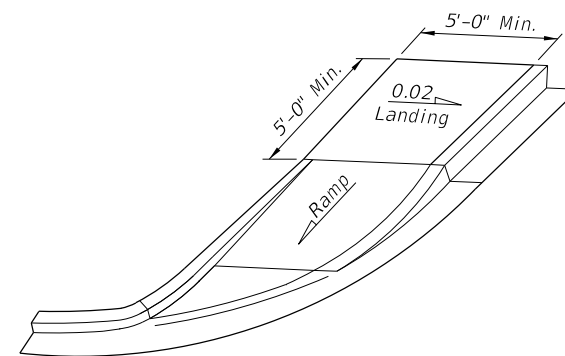
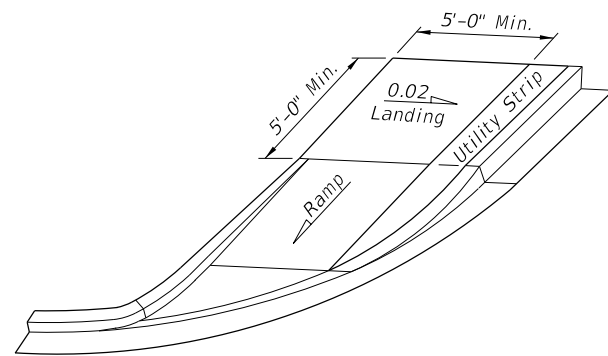

**LANDINGS FOR CURB RAMPS WITHOUT SIDEWALKS**

(See CR-F, CR-G & CR-K Respectively For Detectable Warning Details/Options)

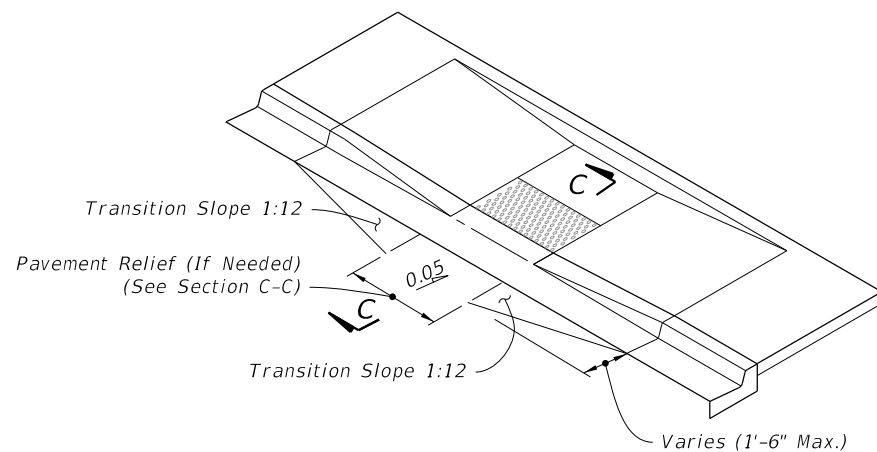

**ISOMETRIC VIEW**  
(CR-C Shown, Other Similar)

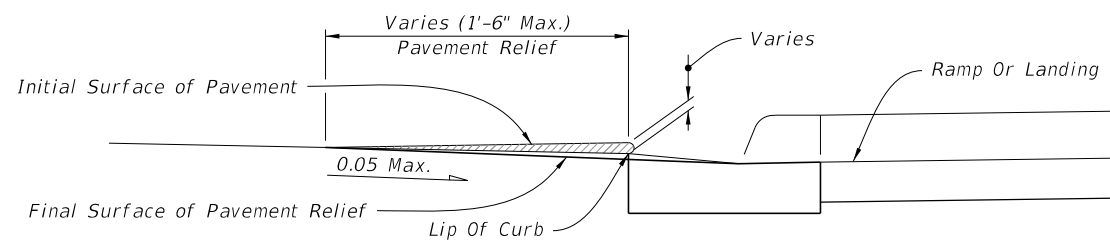

NOTE: Remove Elevated Pavement By Spading And Rolling, Smooth Milling, or Grinding.

**SECTION C-C**

**PAVEMENT RELIEF DETAILS**

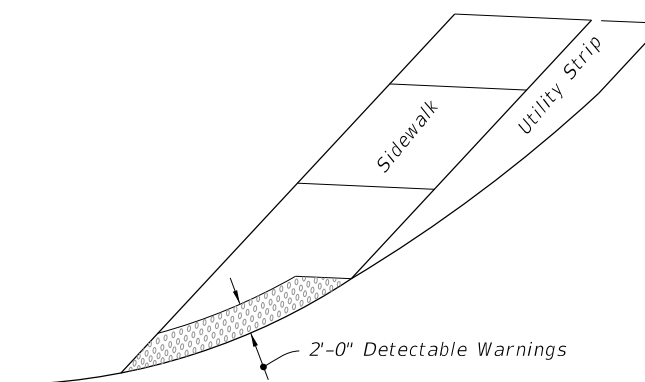

**OPTION A**

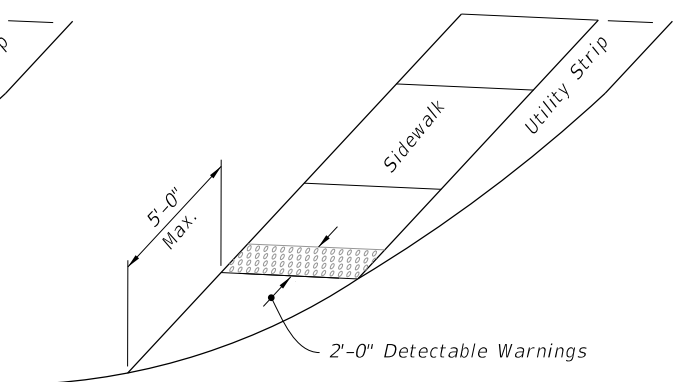

**OPTION B**

**DETECTABLE WARNING ON FLUSH SHOULDER SIDEWALKS**

**CURB RAMPS WITHOUT SIDEWALKS AND FLUSH SHOULDER SIDEWALKS**

7/20/2020 2:10:12 PM

LAST REVISION 11/01/18	DESCRIPTION:
---------------------------	--------------



FY 2020-21  
STANDARD PLANS

DETECTABLE WARNINGS AND SIDEWALK CURB RAMPS

INDEX  
522-002

SHEET  
6 of 7

**NOTES:**

1. Where crosswalk markings are used, ramps must fall within the crosswalk limits. A clear space of 48" minimum is required at the bottom of the ramp within a marked crosswalk. If crosswalk markings are not present, a clear space of 48" minimum is required at the bottom of the ramp outside of active travel lanes.
2. Crosswalk widths and configurations vary; must conform to Index 711-001.
3. Flangeway Gap may be up to 3" for Freight-only Railways.

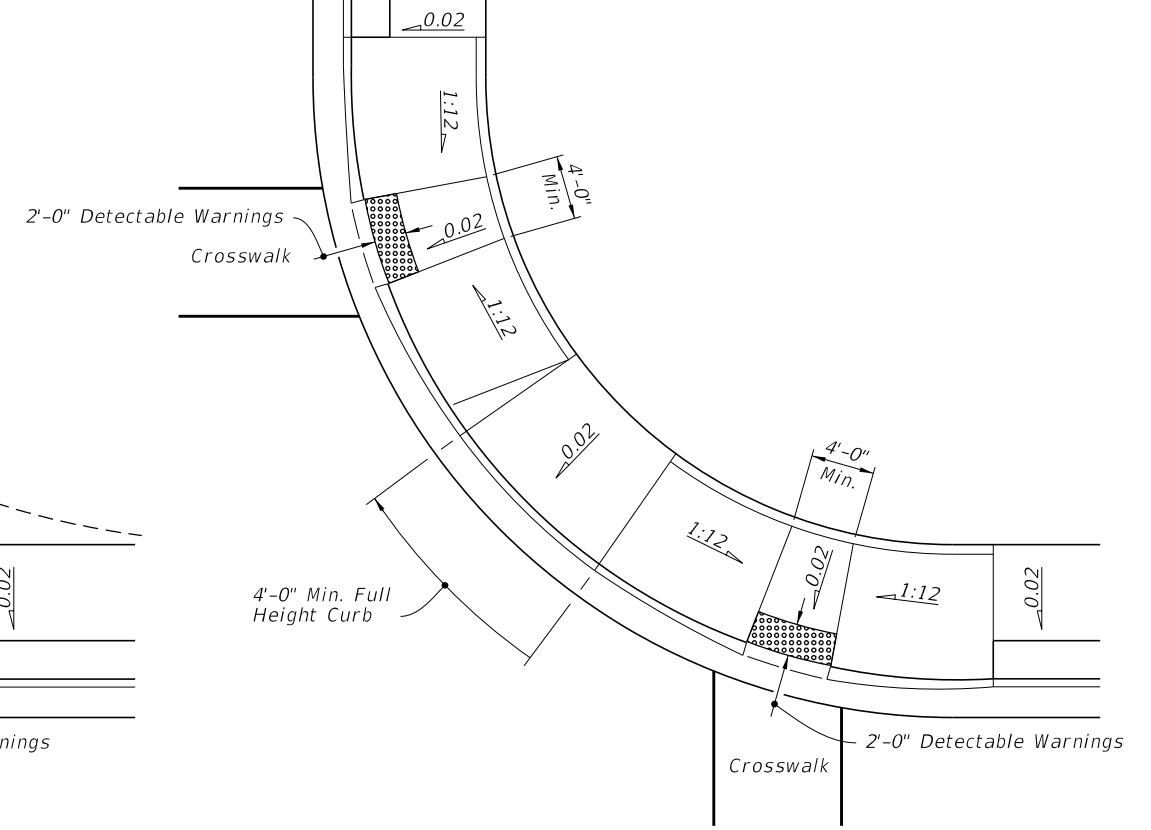
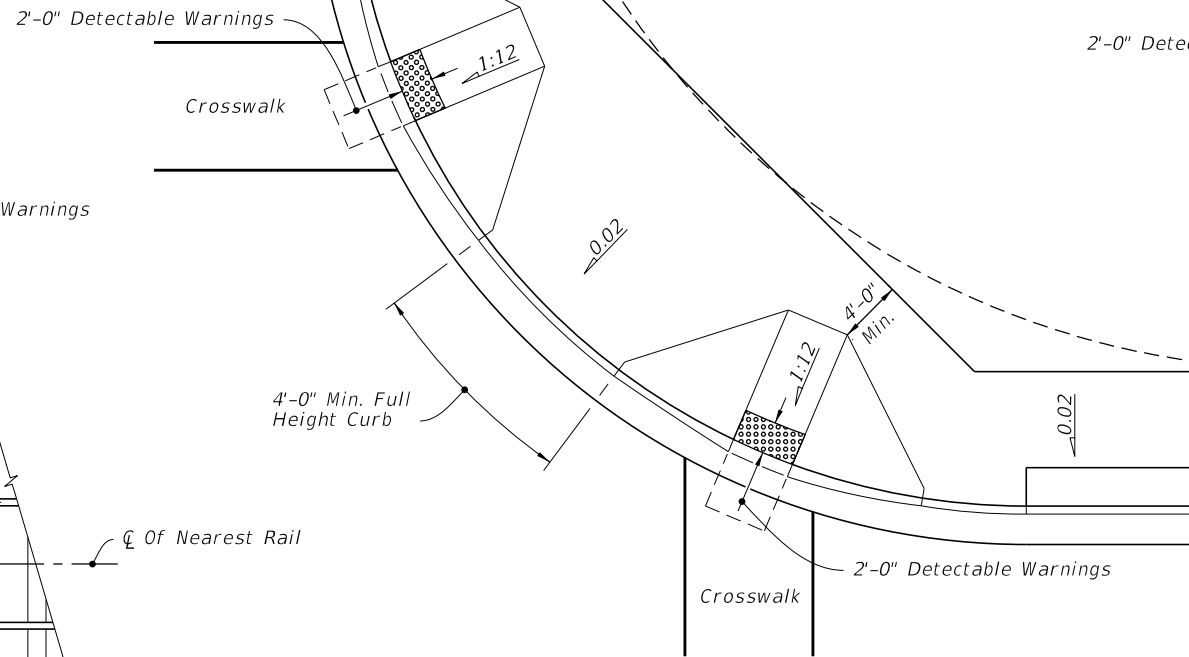
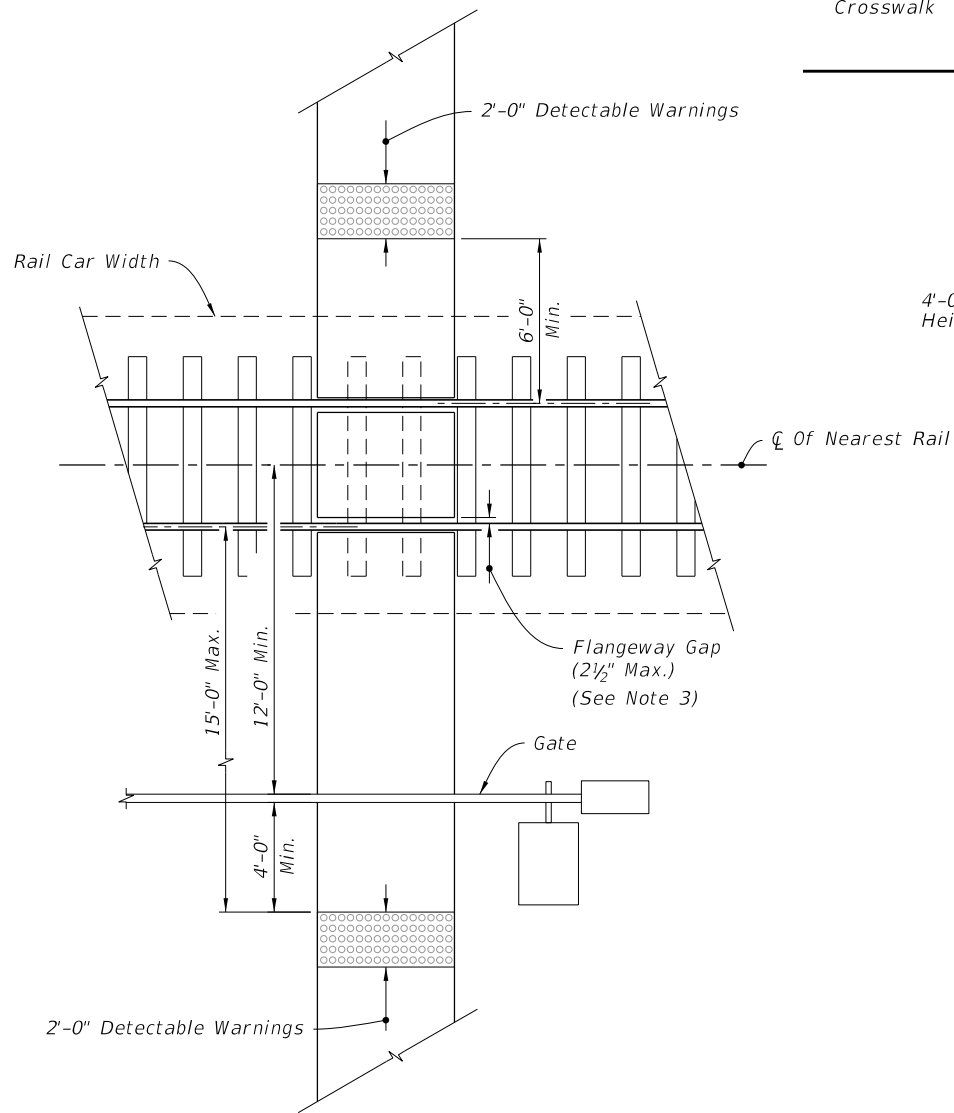

**RADIAL SIDEWALK RAMPS**

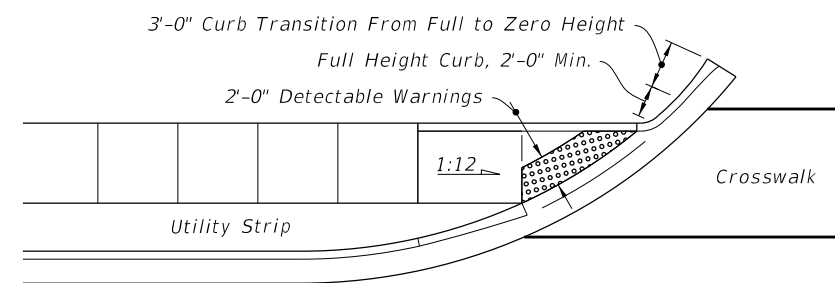

**LINEAR SIDEWALK RAMPS**

RAILROAD CROSSING

PLACEMENT OF SIDEWALK CURB RAMPS AT CURBED RETURNS (TYP.)

**RAILROAD CROSSING AND CURB RAMPS AT CURBED RETURNS**

7/20/2020 2:10:15 PM

LAST REVISION 11/01/17	REVISION	DESCRIPTION:	 FY 2020-21 STANDARD PLANS	DETECTABLE WARNINGS AND SIDEWALK CURB RAMPS	INDEX 522-002	SHEET 7 of 7
---------------------------	----------	--------------	---	---	------------------	-----------------