

GENERAL NOTES:

1. Construct sidewalks in accordance with Specification 522. Use 6" concrete for Sidewalks and Curb Ramps Located within Curb Returns (See Plan View). Install all other concrete with thickness as shown, unless otherwise detailed in the Plans.
2. Include detectable warnings on sidewalk curb ramps in accordance with Index 522-002.
3. For Driveways see Index 522-003.
4. Bond breaker material can be any impermeable coated or sheet membrane or preformed material having a thickness of not less than 6 mils and not more than 1/2".
5. Construct sidewalks with Edge Beam through the limits of any surface mounted Pedestrian/Bicycle Railing or Pipe Guiderail shown in the plans. (See RAILING DETAIL)

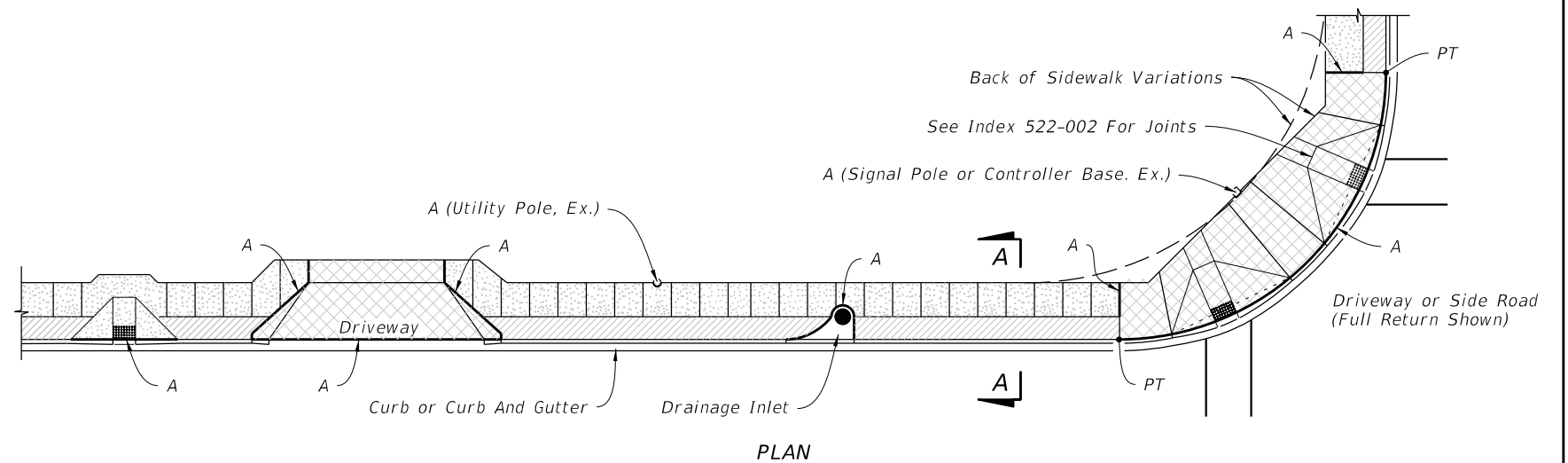

PLAN
SIDEWALK WITH UTILITY STRIP

LEGEND:

- 4" Thick Sidewalk
- 6" Thick Sidewalk
- Utility Strip

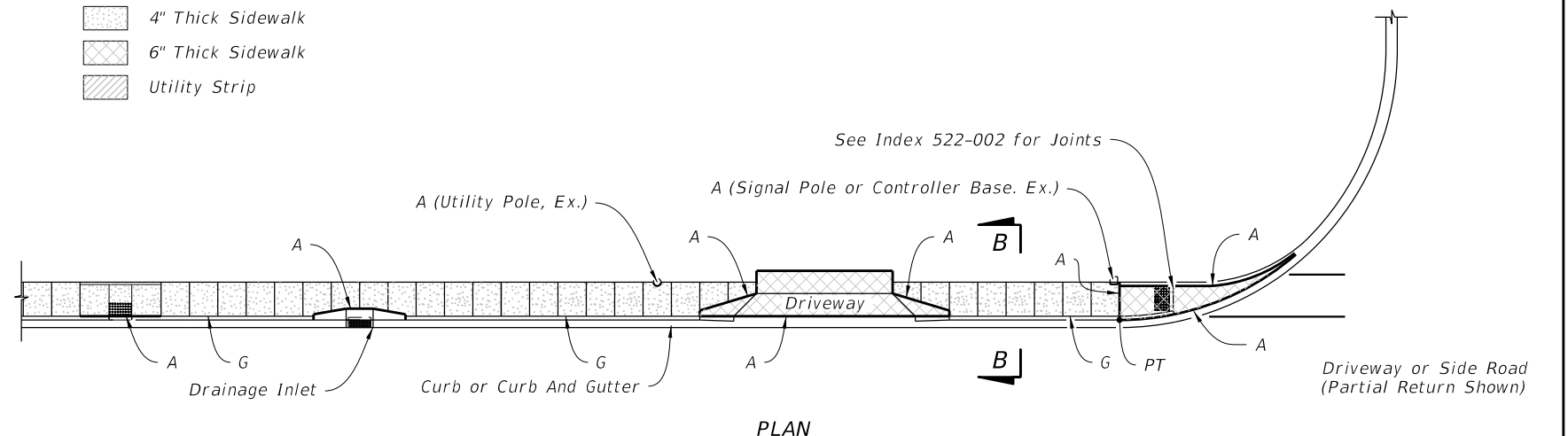

PLAN
SIDEWALK WITHOUT UTILITY STRIP

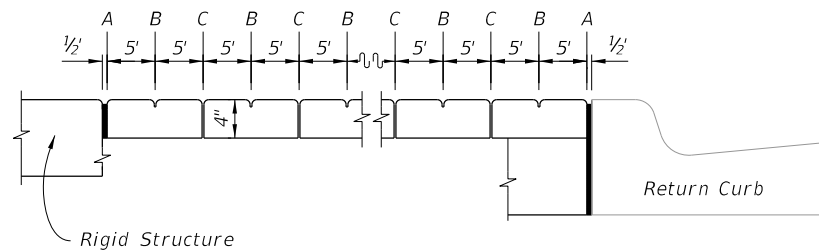

OPEN JOINTS

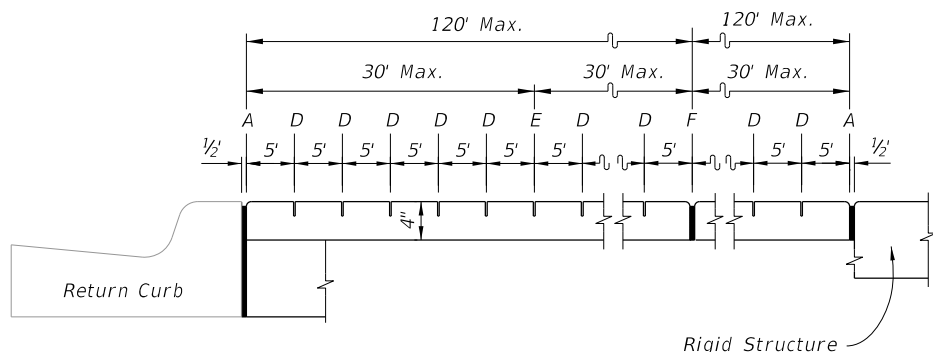

SAWED JOINTS

LONGITUDINAL SECTION

LEGEND:

- A- 1/2" Expansion Joints (Preformed Joint Filler) between the sidewalk and; driveways, sidewalk-intersections, and all other fixed objects (e.g. drainage inlets and utility poles).
- B- 1/8" Dummy Joints, Tooled
- C- 1/8" Formed Open Joints
- D- 3/16" Saw Cut Joints, 1 1/2" Deep (within 96 hours) Max. 5' Centers
- E- 3/16" Saw Cut Joints, 1 1/2" Deep (within 12 hours) Max. 30' Centers Joint(s) Required When Length Exceeds 30'
- F- 1/2" Expansion Joint When Run Of Sidewalk Exceeds 120'. Intermediate locations when called for in the plans or at locations as directed by the Engineer.
- G- Cold Joint With Bond Breaker, Tooled

SIDEWALK JOINTS

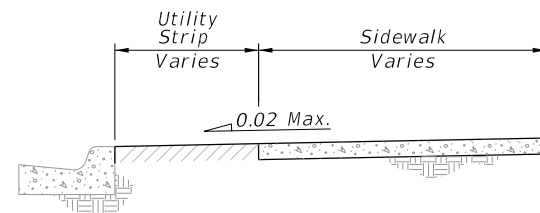

SECTION A-A

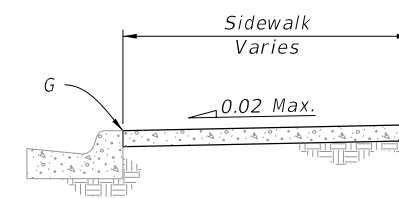

SECTION B-B

Railing (See Index 515-052, 515-062, 515-070 or 515-080)

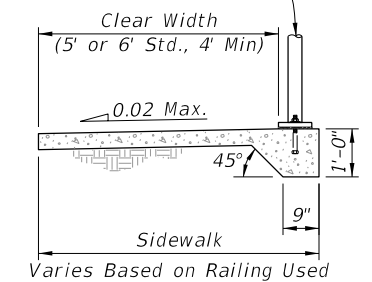

RAILING DETAIL

GENERAL NOTES AND CONCRETE SIDEWALK ON CURBED ROADWAYS

10/14/2019 11:15:32 AM

LAST REVISION	DESCRIPTION:
11/01/18	



FY 2020-21
STANDARD PLANS

CONCRETE SIDEWALK

INDEX
522-001

SHEET
1 of 2

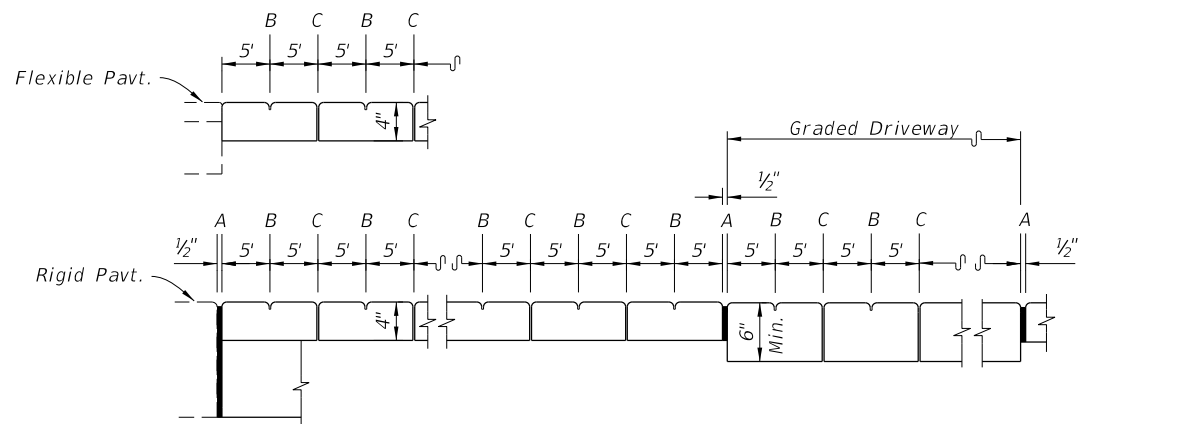

OPEN JOINTS

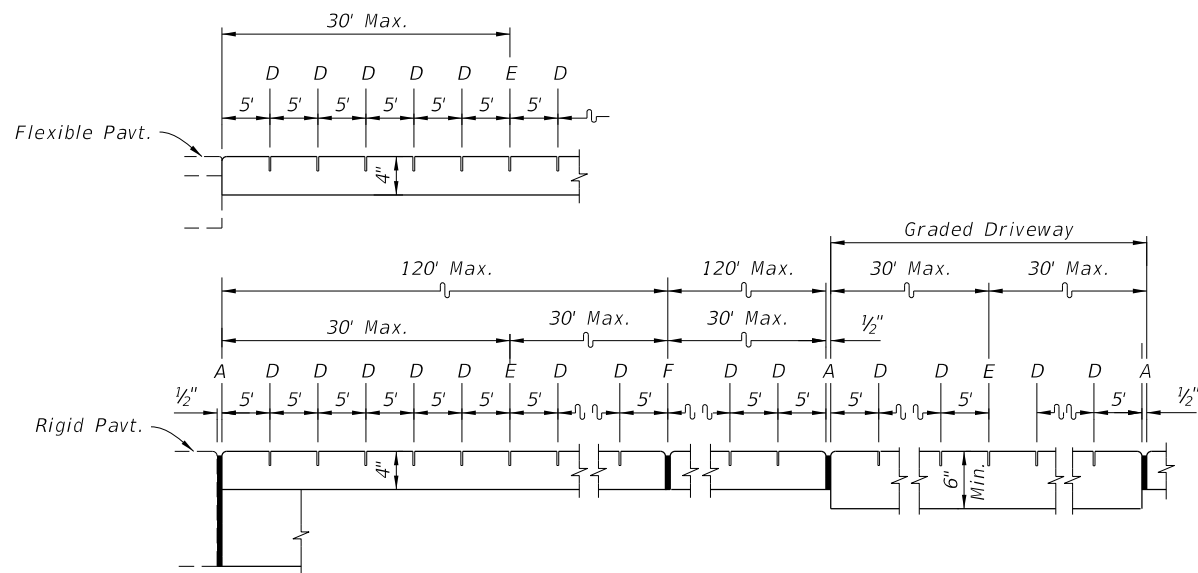

SAWED JOINTS
LONGITUDINAL SECTION

LEGEND:

- A- 1/2" Expansion Joints (Preformed Joint Filler) between the sidewalk and driveways, sidewalk-intersections, and all other fixed objects (e.g. drainage inlets and utility poles).
- B- 1/8" Dummy Joints, Tooled
- C- 1/8" Formed Open Joints
- D- 3/16" Saw Cut Joints, 1 1/2" Deep (within 96 hours) Max. 5' Centers
- E- 3/16" Saw Cut Joints, 1 1/2" Deep (within 12 hours) Max. 30' Centers Joint(s) Required When Length Exceeds 30'
- F- 1/2" Expansion Joint When Run Of Sidewalk Exceeds 120'. Intermediate locations when called for in the plans or at locations as directed by the Engineer.

SIDEWALK JOINTS

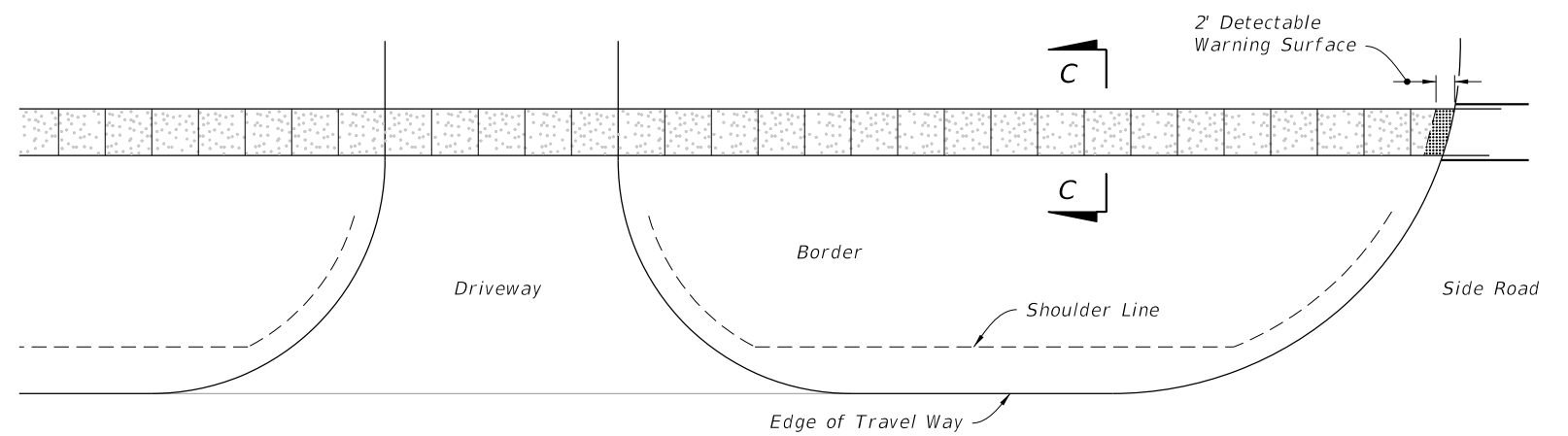

PLAN

CONTINUOUS SIDEWALK

LEGEND:

4" Thick Sidewalk

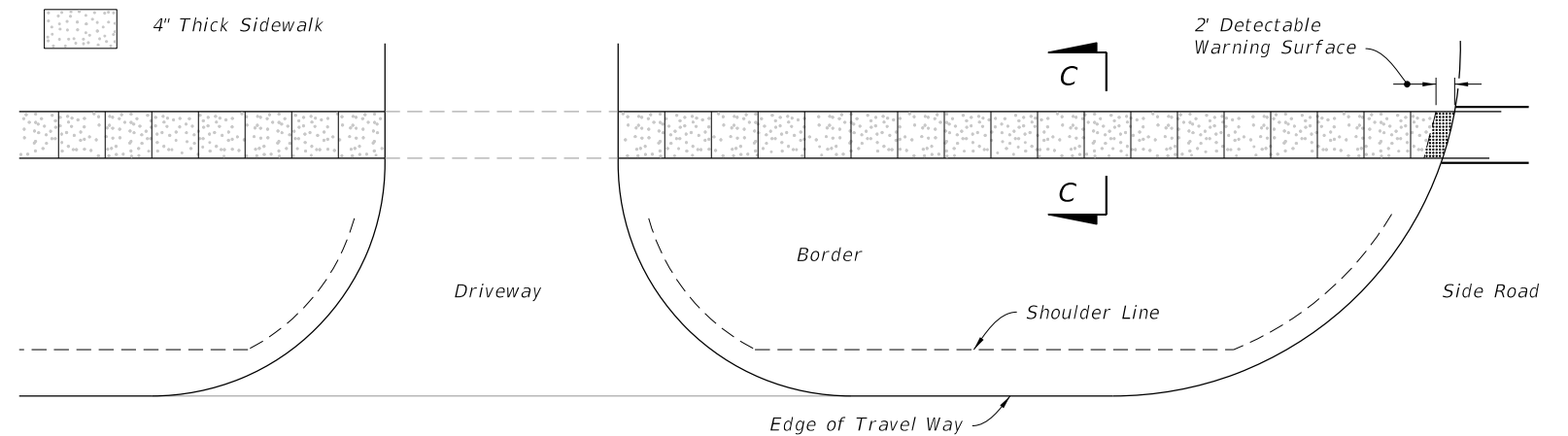

PLAN

DISCONTINUOUS SIDEWALK

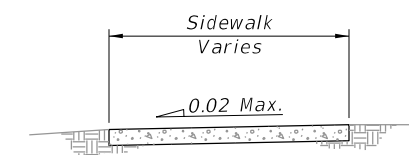

SECTION C-C

CONCRETE SIDEWALK ON FLUSH SHOULDER ROADWAYS

10/14/2019 11:15:33 AM

LAST REVISION 11/01/18	DESCRIPTION:
---------------------------	--------------



FY 2020-21
STANDARD PLANS

CONCRETE SIDEWALK

INDEX
522-001

SHEET
2 of 2