

NAVIGATION LIGHT SYSTEM SCHEMATIC FOR SINGLE BRIDGE WITH FENDERS

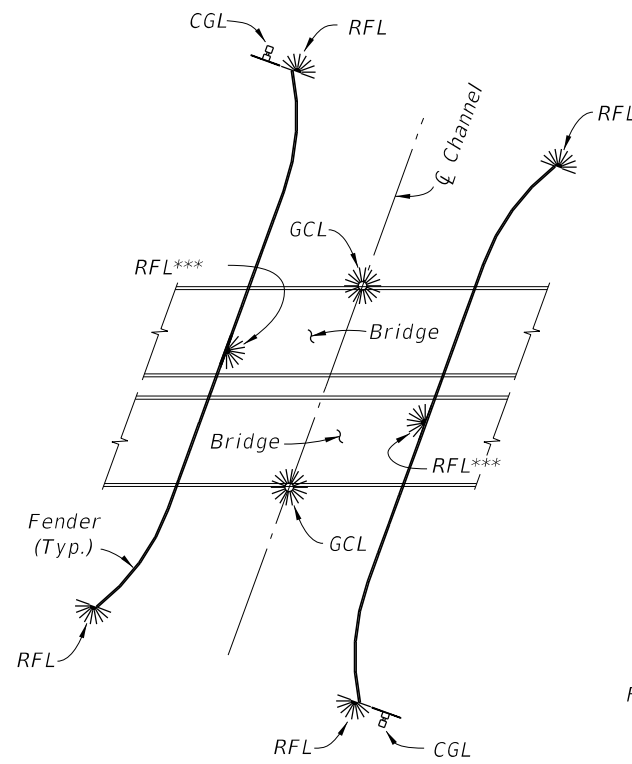

NAVIGATION LIGHT SYSTEM SCHEMATIC FOR DUAL BRIDGES WITH FENDERS

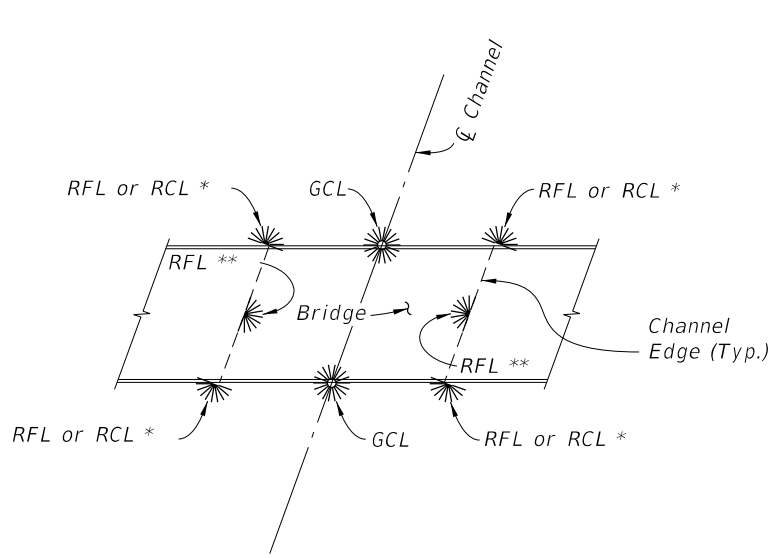

NAVIGATION LIGHT SYSTEM SCHEMATIC FOR SINGLE BRIDGE WITHOUT FENDERS

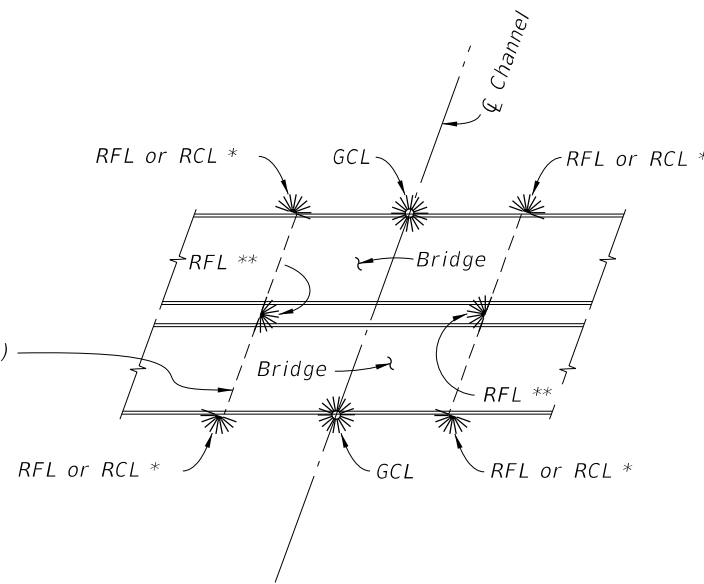

NAVIGATION LIGHT SYSTEM SCHEMATIC FOR DUAL BRIDGES WITHOUT FENDERS

\* Use RFL when Pier is at Channel Edge and see CFR, Title 33, part 118 for Mounting Height restrictions. Use RCL otherwise.  
 \*\* Mounted only on the Pier that defines CM, otherwise does not apply.  
 \*\*\* RFL to be located at mid length of straight portion of fender.

NAVIGATION LIGHT NOTES:

1. Provide Navigation Light System in compliance with Specifications Section 510.

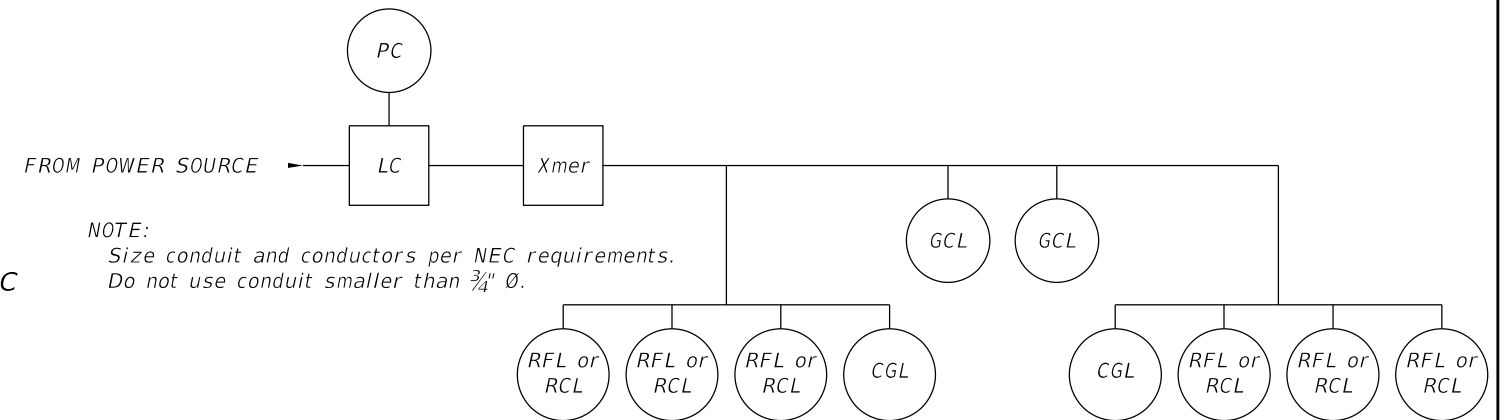

NOTE:  
 Size conduit and conductors per NEC requirements.  
 Do not use conduit smaller than 3/4" Ø.

TYPICAL ELECTRICAL SCHEMATIC DIAGRAM

POWER CONDUCTORS

DISTANCE (feet)	VOLTS	CONDUCTOR	TRANSFORMER
0 - 75	120	#12 AWG	N/A
75 - 500	120 or 240	#10 AWG	N/A
500-1000	240	#10 AWG	N/A
1000-2000	480	#10 AWG	2 KVA
2000-5000	480	#8 AWG	2 KVA
5000-10000	480	#6 AWG	2 KVA
over 10000	480	#4 AWG	2 KVA

LEGEND

SYMBOL	DESCRIPTION
LC	Lighting Contactor
PC	Photocell Control
Xmer	Transformer (If Required)
	RFL or RCL * Red Pier/Fender Light (180° visibility)
	RFL or RCL Red Channel Margin Light (180° visibility)
	GCL Green Center Channel Light (360° visibility)
	CGL Clearance Gauge Light
CM	Channel Margin or Pier inner surface whichever defines Channel Edge.

10/14/2019 3:06:29 PM

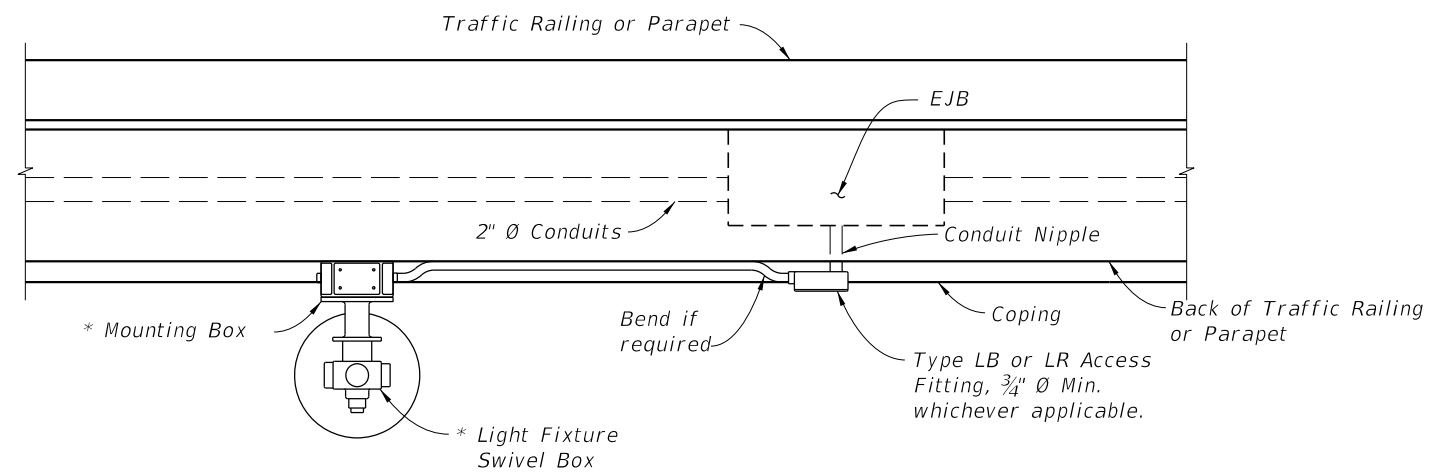

GCL OR RCL MOUNTING DETAILS (SCHEMATIC)  
VIEW A-A

CROSS REFERENCES:  
 1. For Navigation Light System notes and legend, see Sheet 1.  
 2. See Utility Conduit Detail sheets for Embedded Junction Box (EJB) dimensions & locations.  
 \* Supplied by Light Fixture Manufacturer

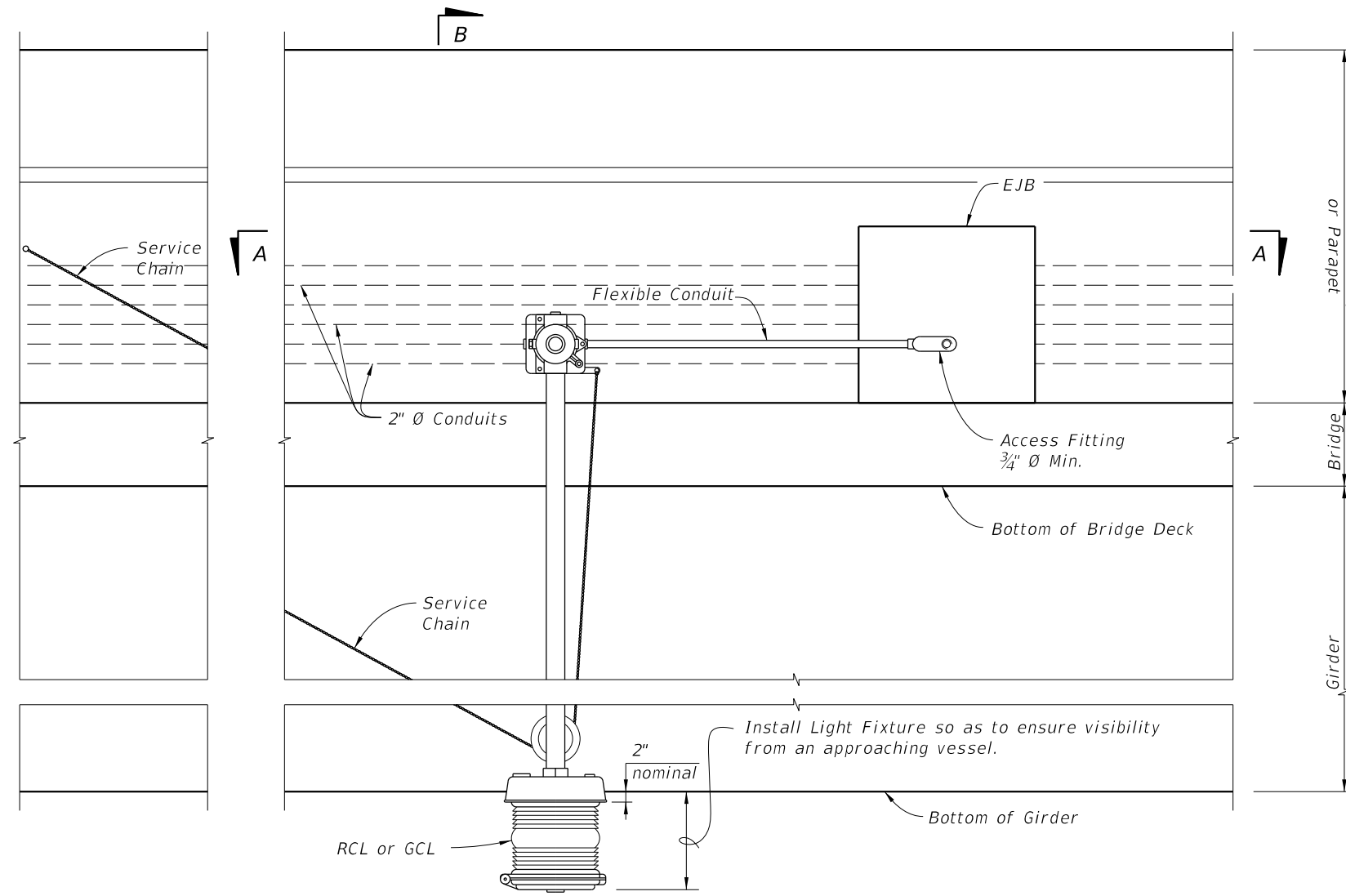

GCL OR RCL MOUNTING DETAILS (SCHEMATIC)  
ELEVATION VIEW  
(Traffic Railing (36" Single-Slope) shown, other railings similar)

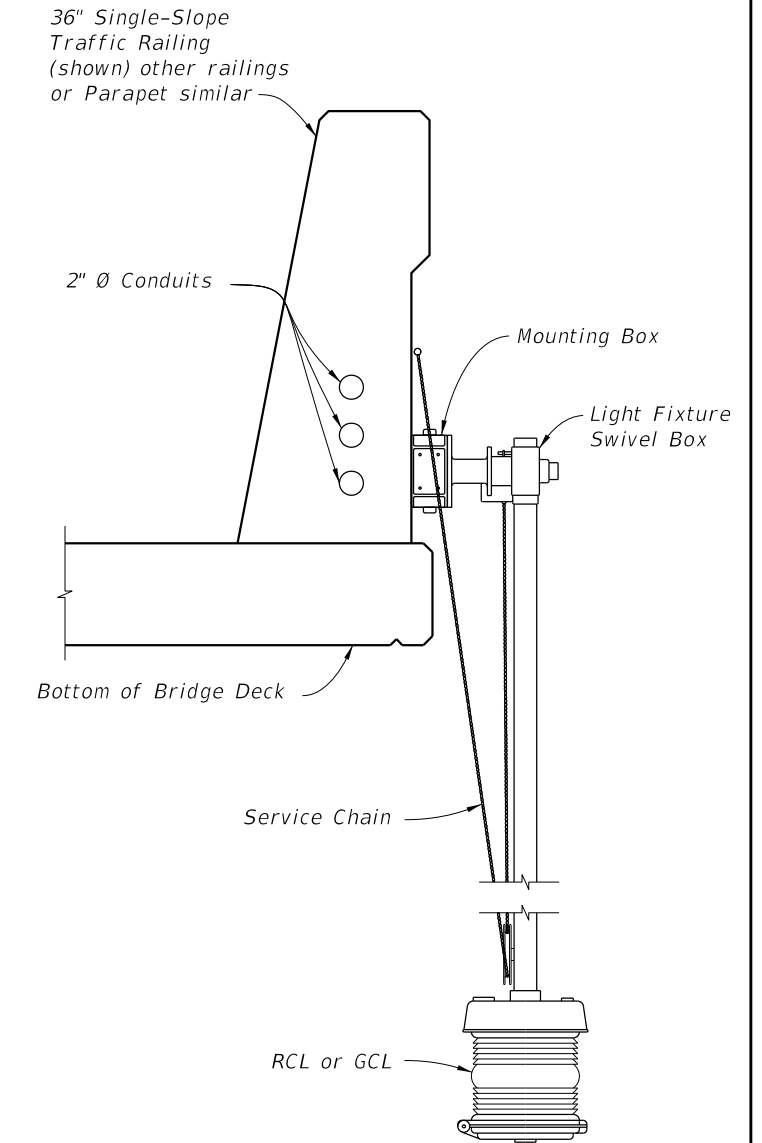

SECTION B-B  
TYPICAL POSITION OF RCL OR GCL  
RELATIVE TO SUPERSTRUCTURES

10/14/2019 3:06:30 PM

LAST REVISION 11/01/17	DESCRIPTION:
---------------------------	--------------



FY 2020-21  
STANDARD PLANS

NAVIGATION LIGHT SYSTEM DETAILS  
(FIXED BRIDGES)

INDEX  
510-001

SHEET  
2 of 2