

PLAN VIEW OF ACCESS HATCH ASSEMBLY

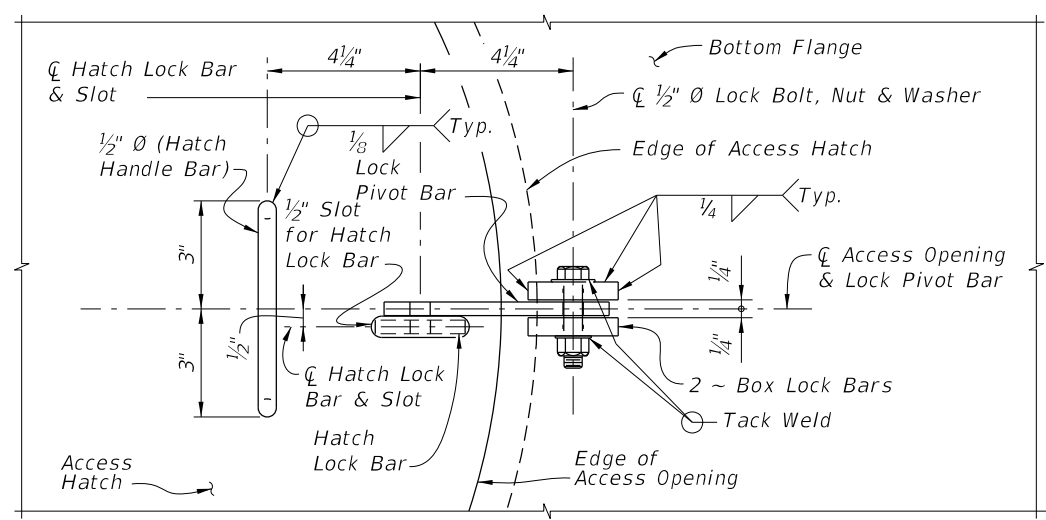

VIEW A-A

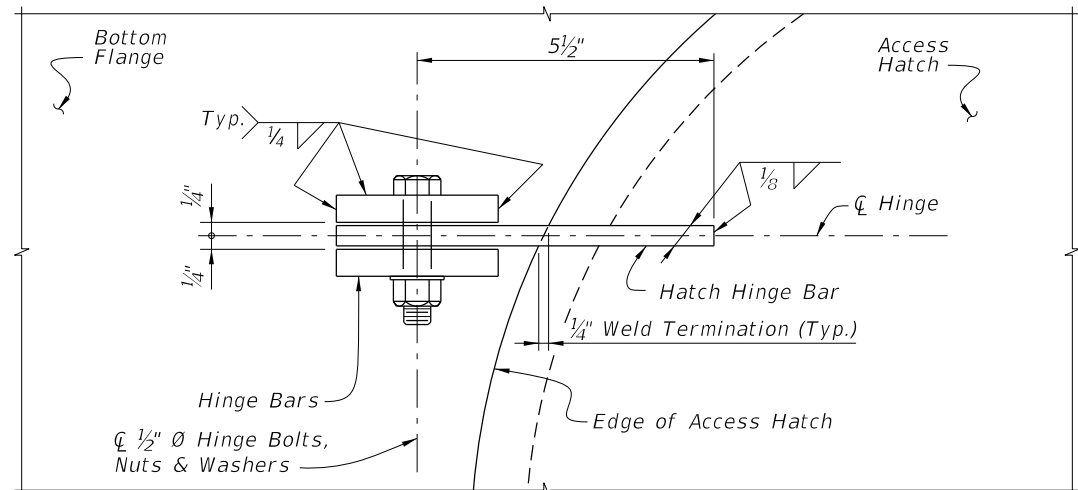

HINGE DETAIL

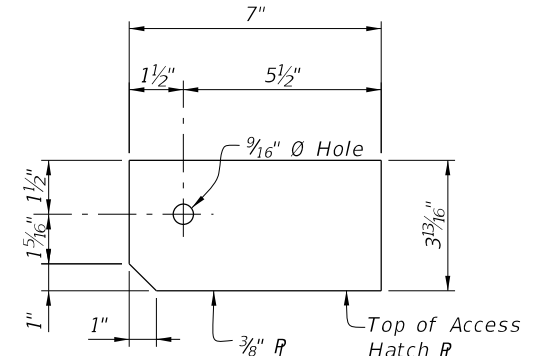

HATCH HINGE BAR DETAIL

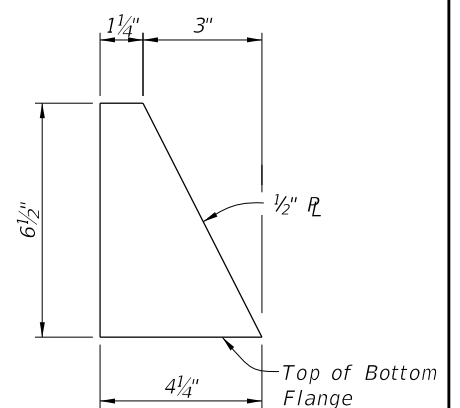

STOP BAR DETAIL

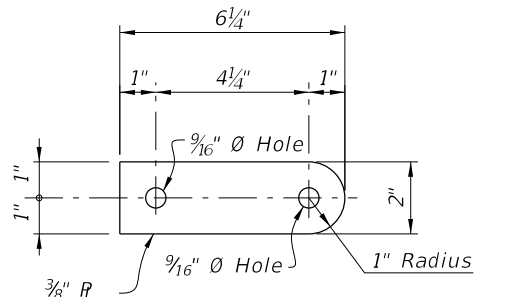

LOCK PIVOT BAR DETAIL

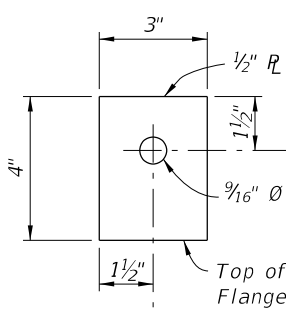

HINGE BAR DETAIL

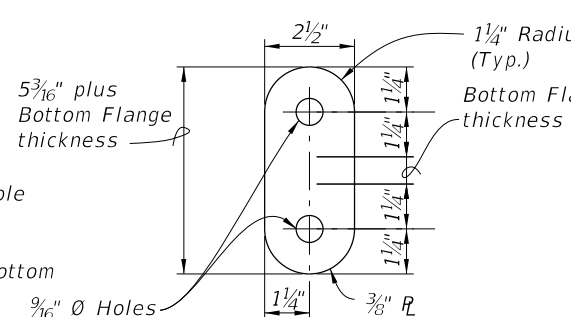

HATCH LOCK BAR DETAIL

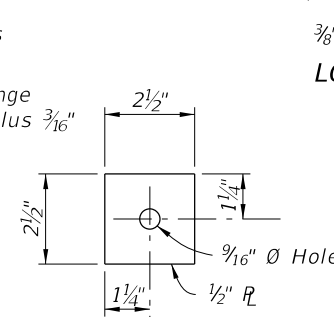

BOX LOCK BAR DETAIL

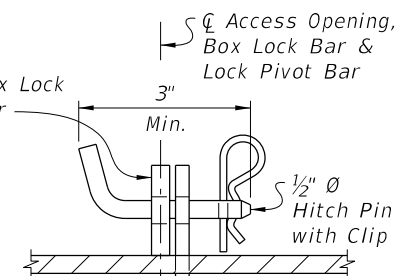

VIEW B-B HATCH LOCK ASSEMBLY DETAIL

HINGE NOTE:
Orient the Access Hatch so that the hinges are located down-grade.

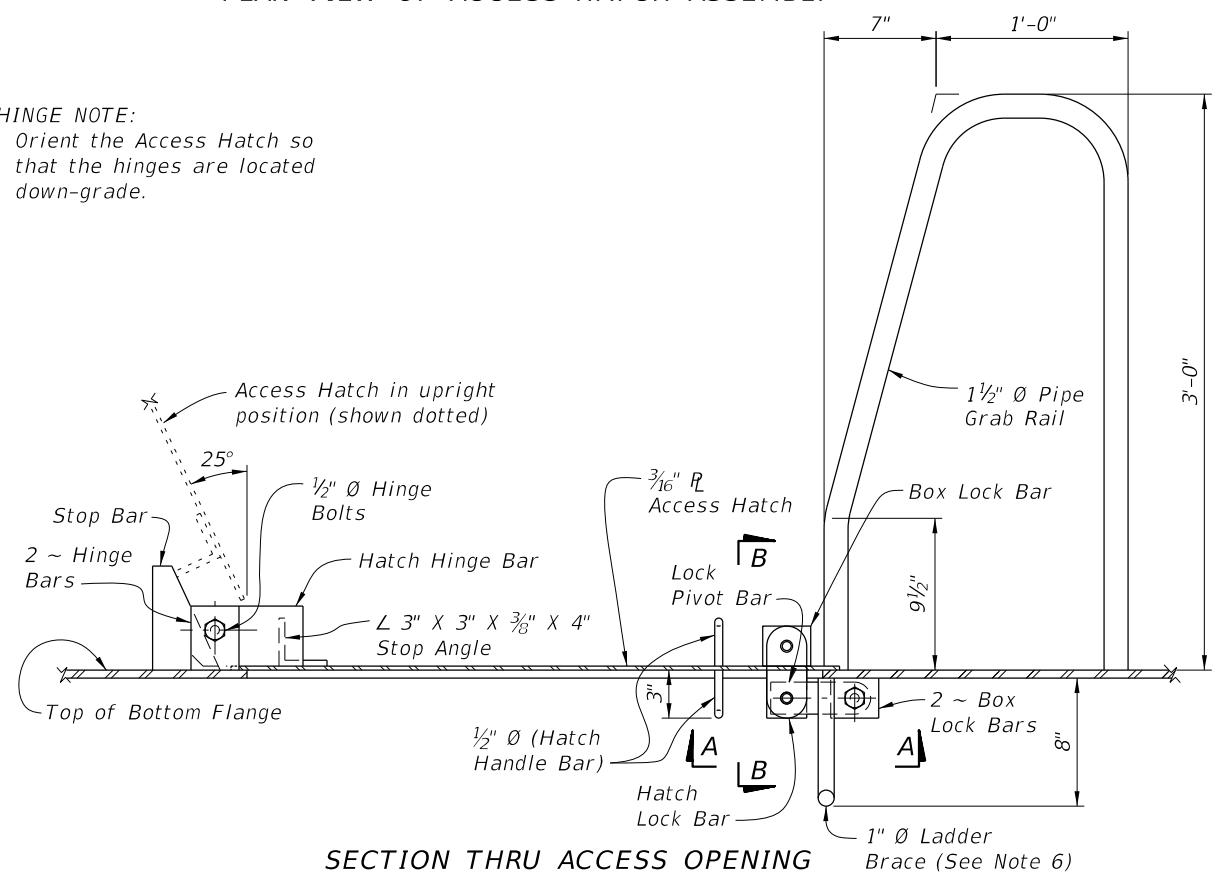

SECTION THRU ACCESS OPENING

- NOTES:
1. All Structural Steel material in Access Hatch Assemblies shall conform to ASTM A709 Grade 36.
 2. 1 1/2" Ø Pipe Grab Rail shall be in accordance with ASTM A53 Grade B for standard weight pipe (Schedule 40).
 3. 1/2" Ø Hatch Handle Bar, Hitch Pin and 1" Ø Ladder Brace shall be in accordance with ASTM A36.
 4. All bolts shall conform to ASTM A307 or A449. All nuts shall conform to ASTM A563 and all washers shall conform to ASTM F-436.
 5. All exposed edges of plates and openings shall be ground smooth.
 6. Place Ladder Brace near the End Bents exclusively and only when the height is reasonable for access by a Ladder.
 7. See Framing Plan sheets for locations of Access Hatch Openings.
 8. Coat structural steel in accordance with Specification Section 560.
 9. Include the cost of the Access Hatch Assembly and incidental items in the cost of the Steel Box Girders. No separate payment will be made for coating structural steel.

10/14/2019 4:05:25 PM

LAST REVISION 07/01/15	DESCRIPTION:	 FY 2020-21 STANDARD PLANS	ACCESS HATCH ASSEMBLY FOR STEEL BOX SECTIONS	INDEX 460-250	SHEET 1 of 1
---------------------------	--------------	--	---	------------------	-----------------