

ELEVATION

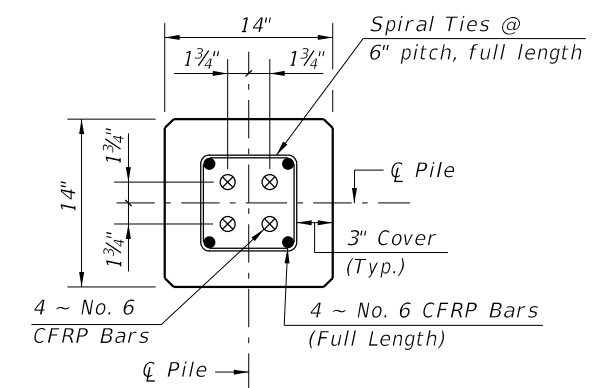

SECTION D-D

(See Non-Drivable Unforescen Reinforced Precast Pile Build-Up Detail)

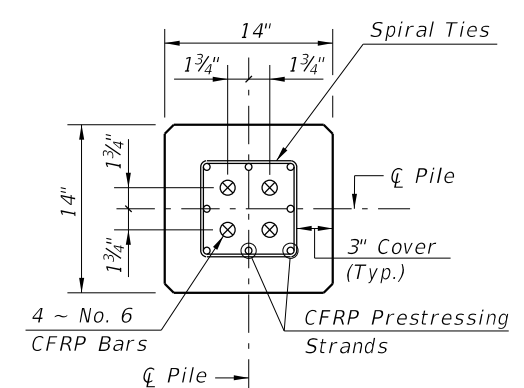

SECTION E-E

(See Drivable Unforescen Prestressed Precast Pile Splice Detail)

ALTERNATE STRAND PATTERNS

- 8 ~ 0.6" Ø, CFRP 7-Strand, at 31.5 kips
- 8 ~ 1/2" Ø, CFRP Single-Strand, at 30.5 kips

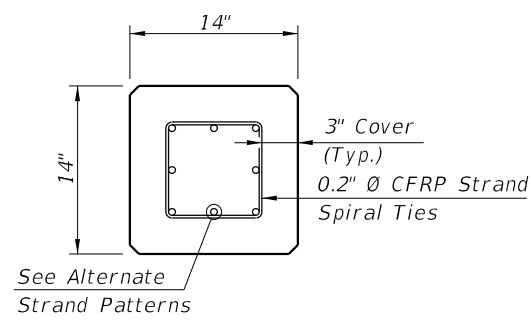

SECTION A-A

CFRP PILE SPLICE REINFORCEMENT DETAILS

NOTES:

1. Work this Index with Index 455-101 - Typical Details and Notes for Square CFRP & SS Prestressed Concrete Piles and Index 455-102 - Square CFRP & SS Prestressed Concrete Pile Splices.
2. Any of the given Alternate Strand Patterns may be utilized. The strands shall be located as follows:
Place one strand at each corner and equally space the remaining strands between the corner strands.
The total strand pattern shall be concentric with the nominal concrete section of the pile.

CFRP PRESTRESSED PILE DETAILS

10/14/2019 4:02:39 PM

LAST REVISION 11/01/16	REVISION	DESCRIPTION:		FY 2020-21 STANDARD PLANS	14" SQUARE CFRP & SS PRESTRESSED CONCRETE PILE	INDEX 455-114	SHEET 1 of 2
---------------------------	----------	--------------	--	------------------------------	---	------------------	-----------------

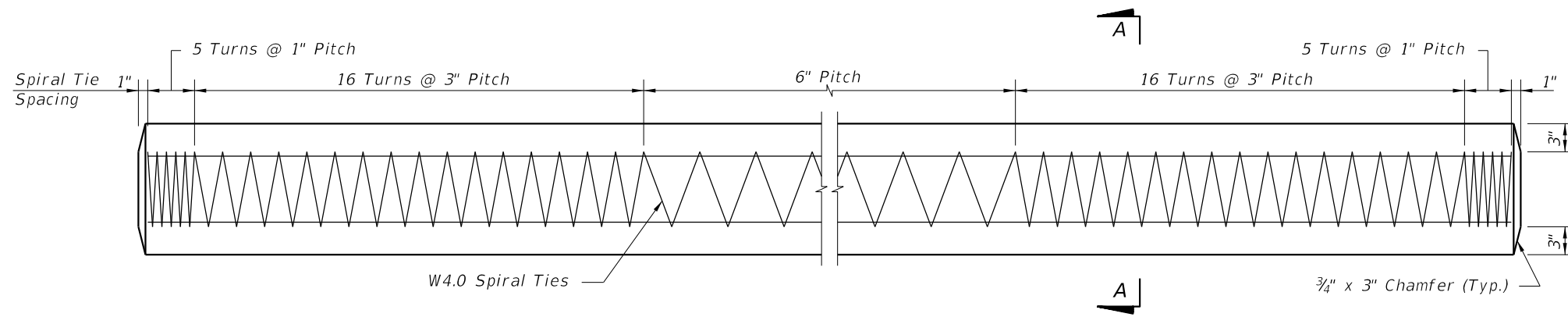

ELEVATION

STRAND PATTERN

12 ~ 1/2" Ø, HSSS at 23 kips

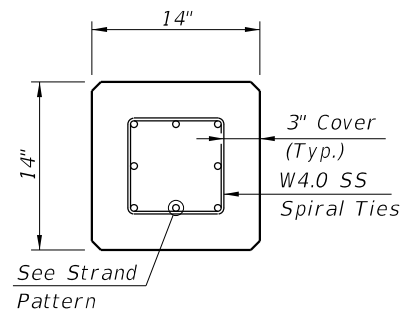

SECTION A-A

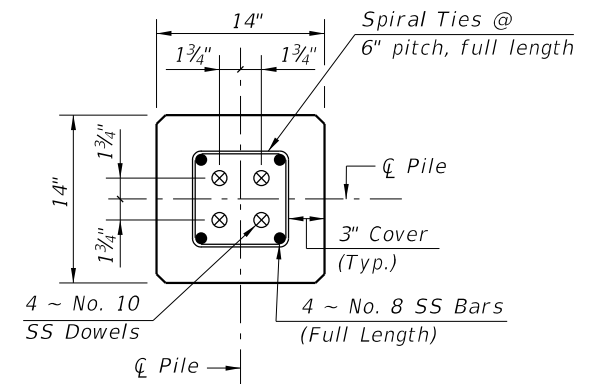

SECTION D-D

(See Non-Drivable Unforeseen Reinforced Precast Pile Build-Up Detail)

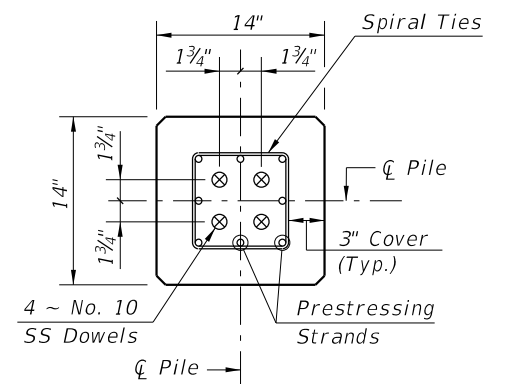

SECTION E-E

(See Drivable Unforeseen Prestressed Precast Splice Detail)

SS PILE SPLICE REINFORCEMENT DETAILS

NOTES:

1. Work this Index with Index 455-101 - Typical Details and Notes for Square CFRP & SS Prestressed Concrete Piles and Index 455-102 - Square CFRP & SS Prestressed Concrete Pile Splices.
2. Any of the given Alternate Strand Patterns may be utilized. The strands shall be located as follows:
Place one strand at each corner and place the remaining strands equally spaced between the corner strands.
The total strand pattern shall be concentric with the nominal concrete section of the pile.

SS PRESTRESSED PILE DETAILS

10/14/2019 4:02:39 PM

LAST REVISION 01/01/16	REVISION	DESCRIPTION:		FY 2020-21 STANDARD PLANS	14" SQUARE CFRP & SS PRESTRESSED CONCRETE PILE	INDEX 455-114	SHEET 2 of 2
---------------------------	----------	--------------	--	------------------------------	---	------------------	-----------------