

GENERAL NOTES:

1. Use Class I concrete.
2. Chamfer all exposed edges and corners $\frac{3}{4}$ " unless otherwise shown.
3. Quantities shown are for estimating purposes only.

TABLE OF CONTENTS:	
Sheet	Description
1	General Notes and Contents
2	U-Type and 45° Endwalls

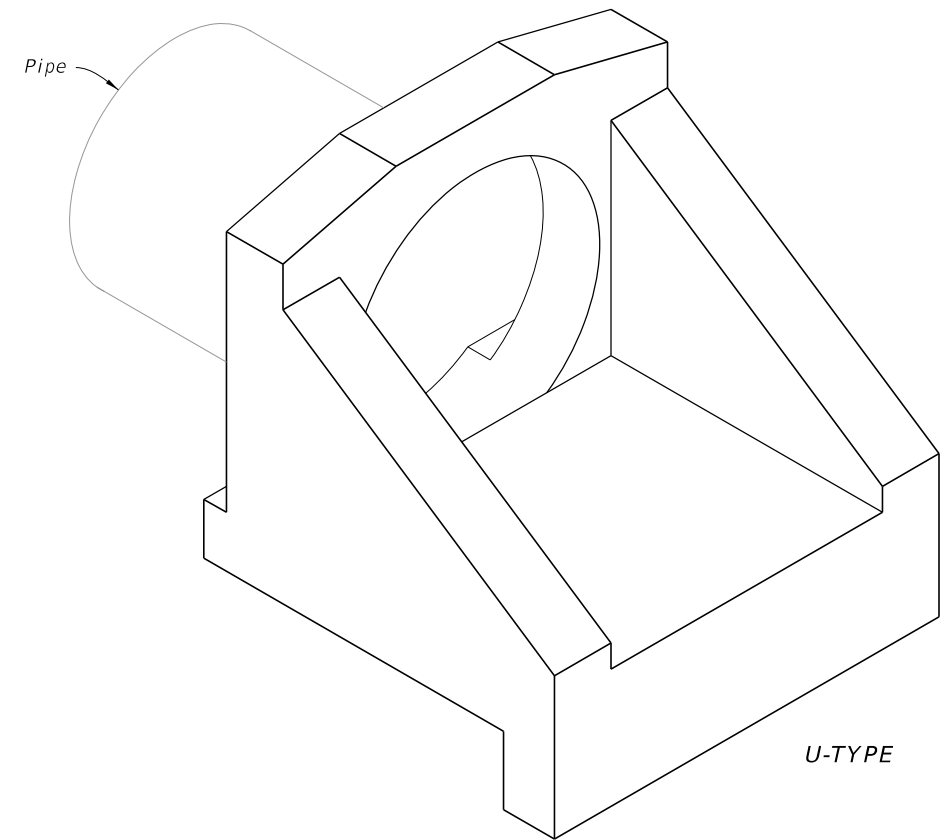
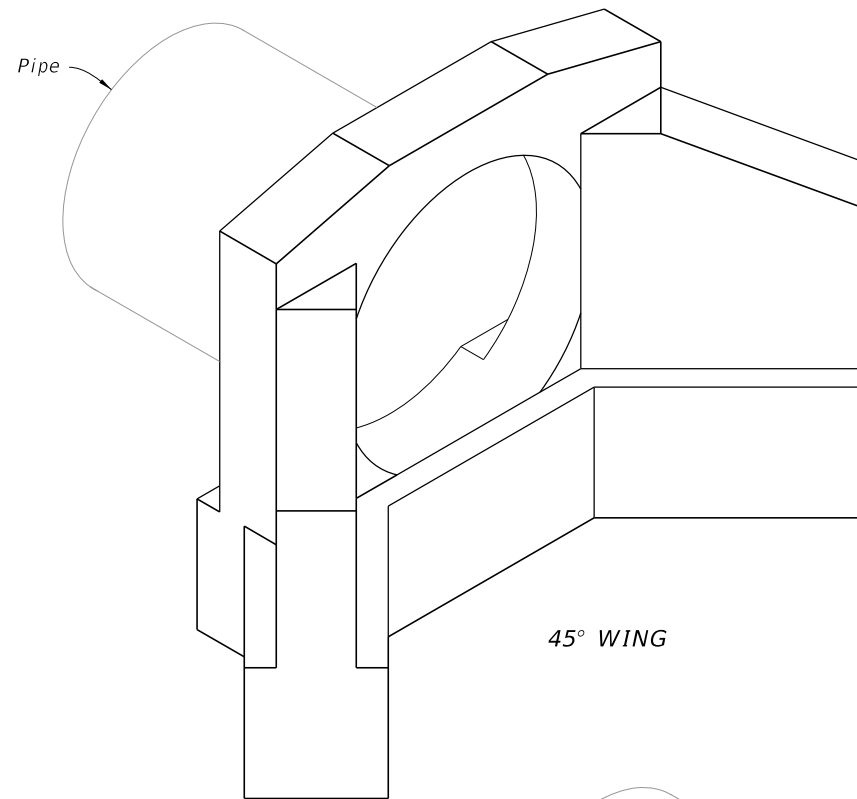

===== WINGED CONCRETE ENDWALLS =====

10/14/2019 10:04:43 AM

LAST REVISION	DESCRIPTION:
11/01/19	

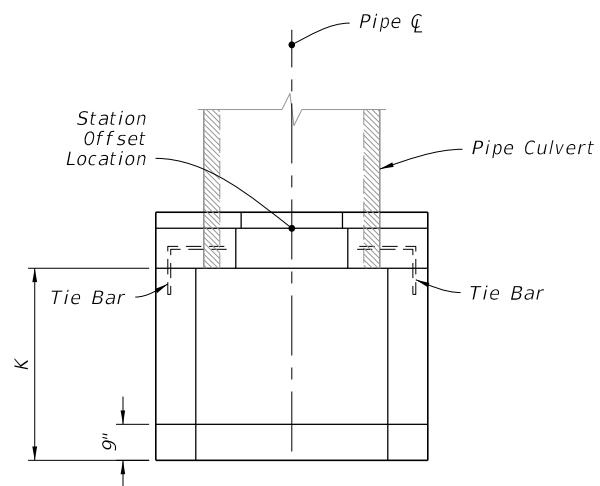

PLAN

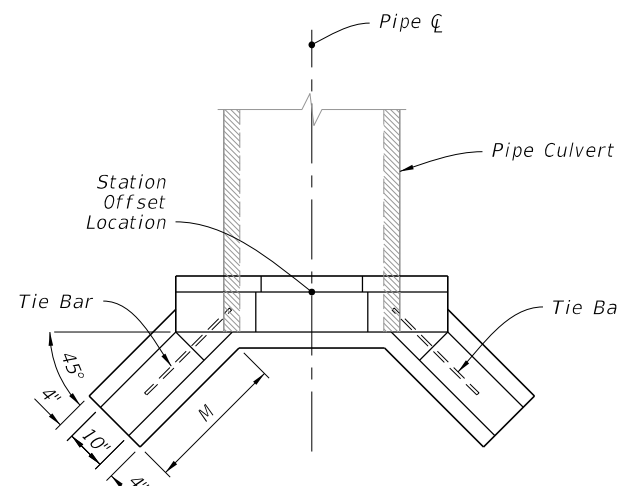

PLAN

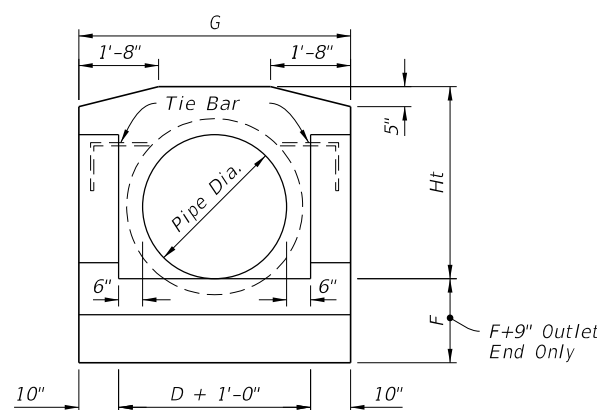

FRONT ELEVATION

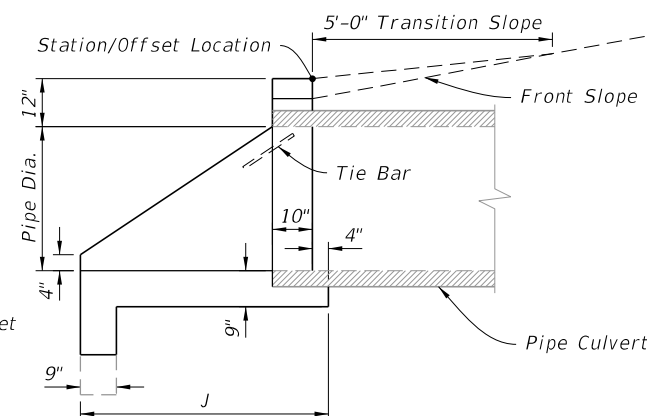

SIDE ELEVATION

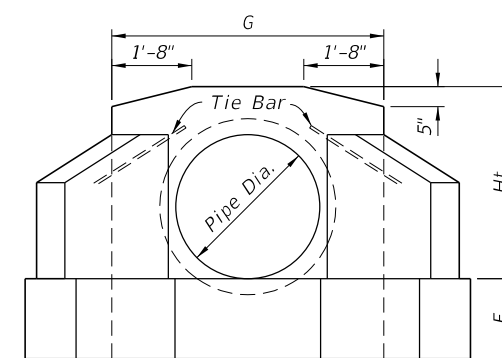

FRONT ELEVATION

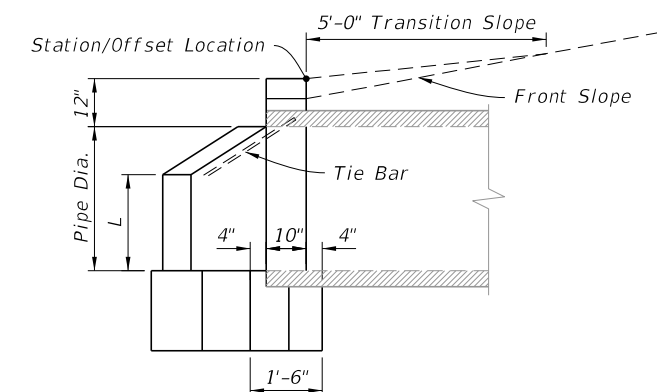

SIDE ELEVATION

DIMENSIONS AND ESTIMATED QUANTITIES PIPE CULVERT ENDWALLS WITH U-TYPE WINGS													
DIMENSIONS							QUANTITIES IN ONE ENDWALL						
Pipe Dia.	Area (ft ²)	Wall		Footing			Concrete, Class I, Total (CY)						Steel Tie Bars
		G	Ht	K	F	J	RCP		CMP		CIP		
							Inlet	Outlet	Inlet	Outlet	Inlet	Outlet	
15"	1.2	3'-11"	2'-3"	1'-5"	1'-3"	2'-7"	0.59	0.67	0.62	0.70	0.61	0.70	none
18"	1.8	4'-2"	2'-6"	1'-9"	1'-3"	2'-11"	0.70	0.79	0.74	0.82	0.74	0.82	none
24"	3.1	4'-8"	3'-0"	2'-6"	1'-6"	3'-8"	1.01	1.11	1.06	1.16	1.06	1.16	2-#6 Bars x 2'-0"
30"	4.9	5'-2"	3'-6"	3'-3"	1'-6"	4'-5"	1.33	1.44	1.41	1.51	1.40	1.51	2-#6 Bars x 2'-0"
36"	7.1	5'-8"	4'-0"	4'-0"	1'-9"	5'-2"	1.73	1.85	1.84	1.96	1.82	1.94	2-#6 Bars x 2'-6"
42"	9.6	6'-2"	4'-6"	4'-9"	2'-0"	5'-11"	2.19	2.32	2.32	2.45			2-#6 Bars x 2'-6"
48"	12.6	6'-8"	5'-0"	5'-6"	2'-0"	6'-8"	2.64	2.78	2.81	2.95			2-#6 Bars x 3'-0"

ENDWALL WITH U-TYPE WINGS

DIMENSIONS AND ESTIMATED QUANTITIES PIPE CULVERT ENDWALLS WITH 45° WINGS											
DIMENSIONS							QUANTITIES IN ONE ENDWALL				
Pipe Dia.	Area (ft ²)	Ht	Wall			Footing	Concrete, Class I			Steel Tie Bars	
			G	L	M		Total (CY)				
						RCP		CMP	CIP		
15"	1.2	2'-3"	3'-7"	1'-0"	1'-3"	1'-3"	0.56	0.59	0.59	none	
18"	1.8	2'-6"	3'-10"	1'-2"	1'-7"	1'-3"	0.74	0.77	0.77	none	
24"	3.1	3'-0"	4'-4"	1'-5"	2'-1"	1'-4"	1.01	1.06	1.06	2-#6 Bars x 2'-0"	
30"	4.9	3'-6"	4'-10"	1'-9"	2'-5"	1'-6"	1.32	1.40	1.39	2-#6 Bars x 2'-0"	
36"	7.1	4'-0"	5'-4"	2'-0"	2'-11"	1'-8"	1.72	1.83	1.82	2-#6 Bars x 2'-6"	
42"	9.6	4'-6"	5'-10"	2'-3"	3'-6"	2'-0"	2.34	2.47		2-#6 Bars x 2'-6"	
48"	12.6	5'-0"	6'-4"	2'-6"	4'-0"	2'-0"	2.74	2.90		2-#6 Bars x 2'-6"	

ENDWALL WITH 45° WINGS

10/14/2019 10:04:43 AM

U-TYPE AND 45° ENDWALLS

LAST REVISION 11/01/19	REVISION	DESCRIPTION:
---------------------------	----------	--------------



FY 2020-21
STANDARD PLANS

WINGED CONCRETE ENDWALLS

INDEX
430-040

SHEET
2 of 2