

NOTES:

1. These details are for construction field expediency to resolve utility conflicts that cannot be remedied by relocation. For conflicts determined during design, use the construction shop drawings for structure details.
2. Concrete used in conflict structures shall be as specified in ASTM C478. 4000 psi may be used in lieu of Class I concrete.
3. Maximum opening for pipe shall be the pipe OD plus 6". Mortar used to seal the pipe into the opening will be of such mix that shrinkage will not cause leakage into or out of the structure.
4. If the conflict structure is round or there are multiple inlet or outlet pipes, then the wall section should be reviewed for strength.
5. If during construction or the plans design process it is determined that a potable water supply line must pass through a storm drain structure, it must be in compliance with Chapter 62-555.314 (3) F.A.C. and shown on the design or construction plans and submitted to the Florida Department of Environmental Protection (FDEP) Administrator For Drinking Water in the respective FDEP District for review and comment. This index and rule citation provide accepted methods for addressing conflicts when and where they cannot be reasonably avoided. To be submitted along with the plans shall be a justification describing inordinate cost and the impracticality of avoidance. If identified, properly justified, and accomplished in accordance with this index, approval is granted. Upon request, the Utility Agency Owner (UAO) must provide support data on the cost of relocation or adjustment to the FDOT for submittal to the FDEP. See the following web site for District FDEP Drinking Water Contacts: www.dep.state.fl.us/water/drinkingwater/index.htm and click on "Organization" on the menu to the right.

DESIGNER'S NOTES:

"Sumped" conflict manholes shall not be used unless the system is hydraulically designed to account for the headloss generated if the sump is completely blocked

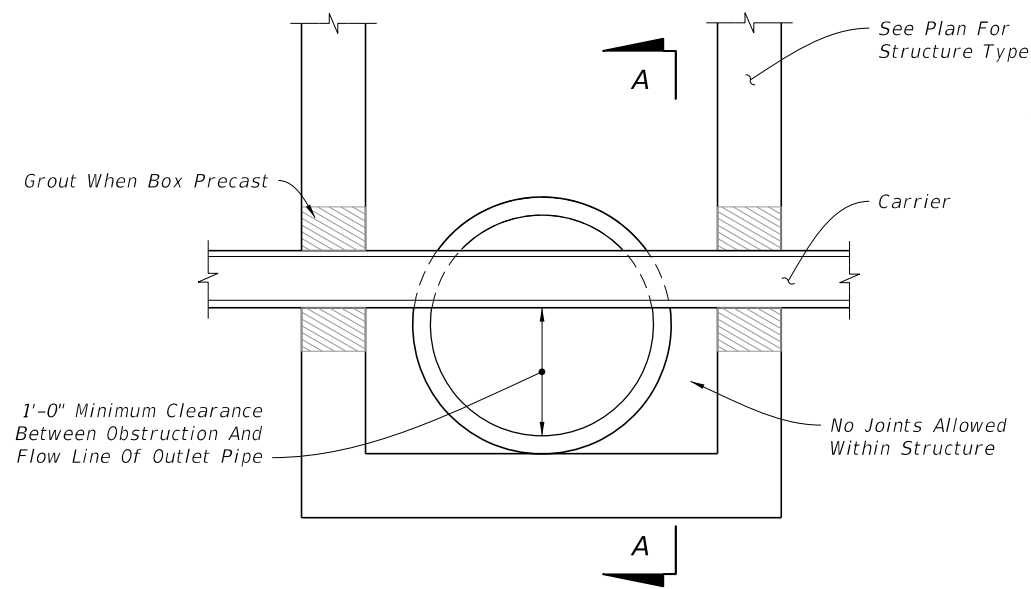

SECTION LONGITUDINAL TO CARRIER PIPE

UTILITY CONFLICT CONDITION I

(Nonpressure Or Nonfluid Carrier Installations)

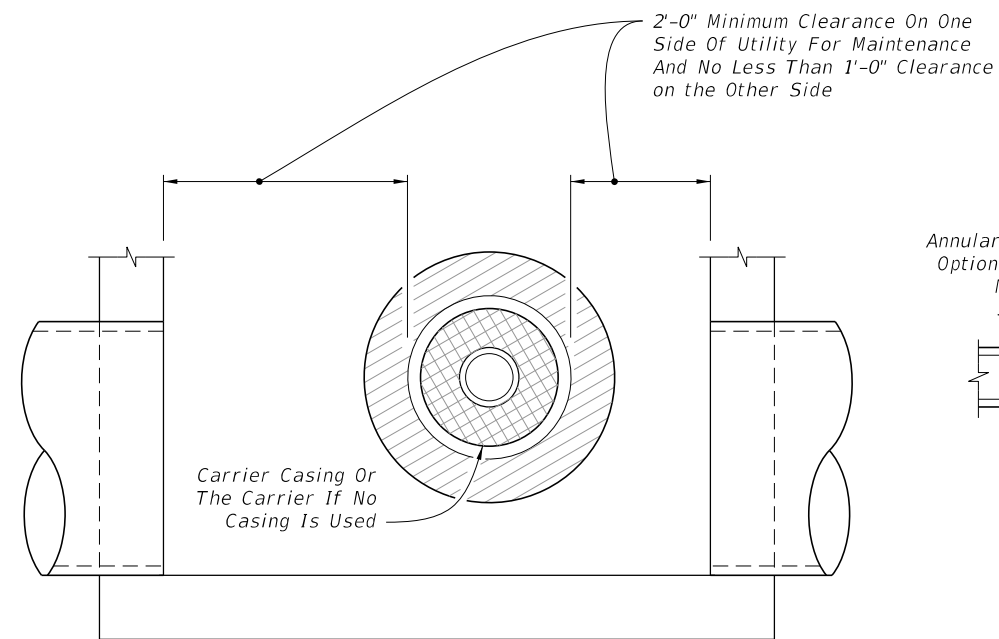

SECTION A-A

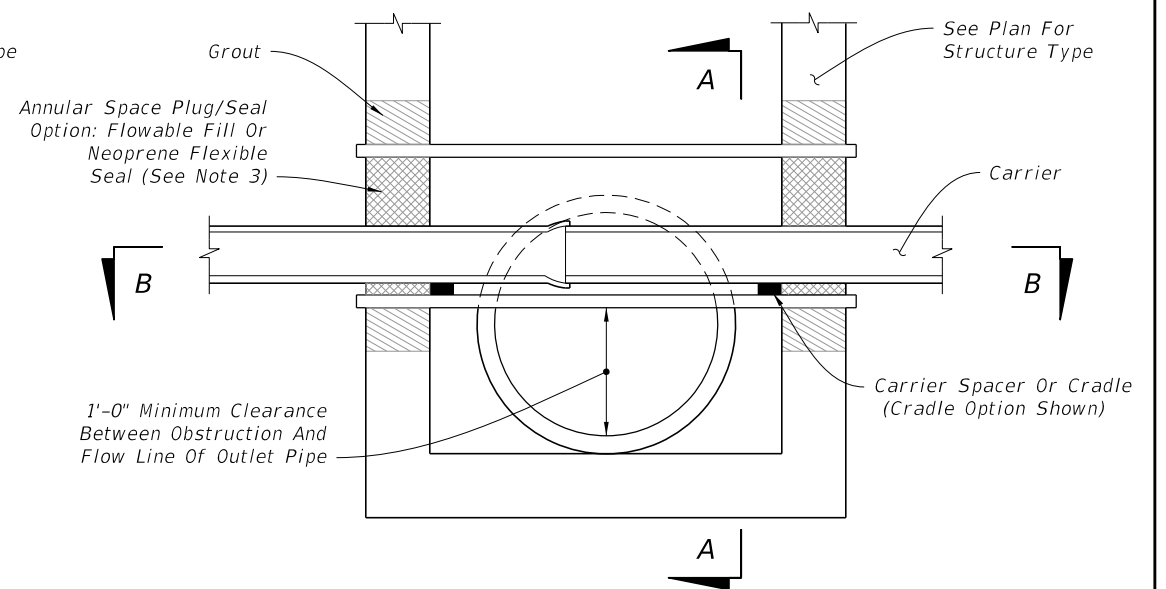

SECTION LONGITUDINAL TO CARRIER PIPE

UTILITY CONFLICT CONDITION II

(Pressure Or Fluid Carrier Installations)

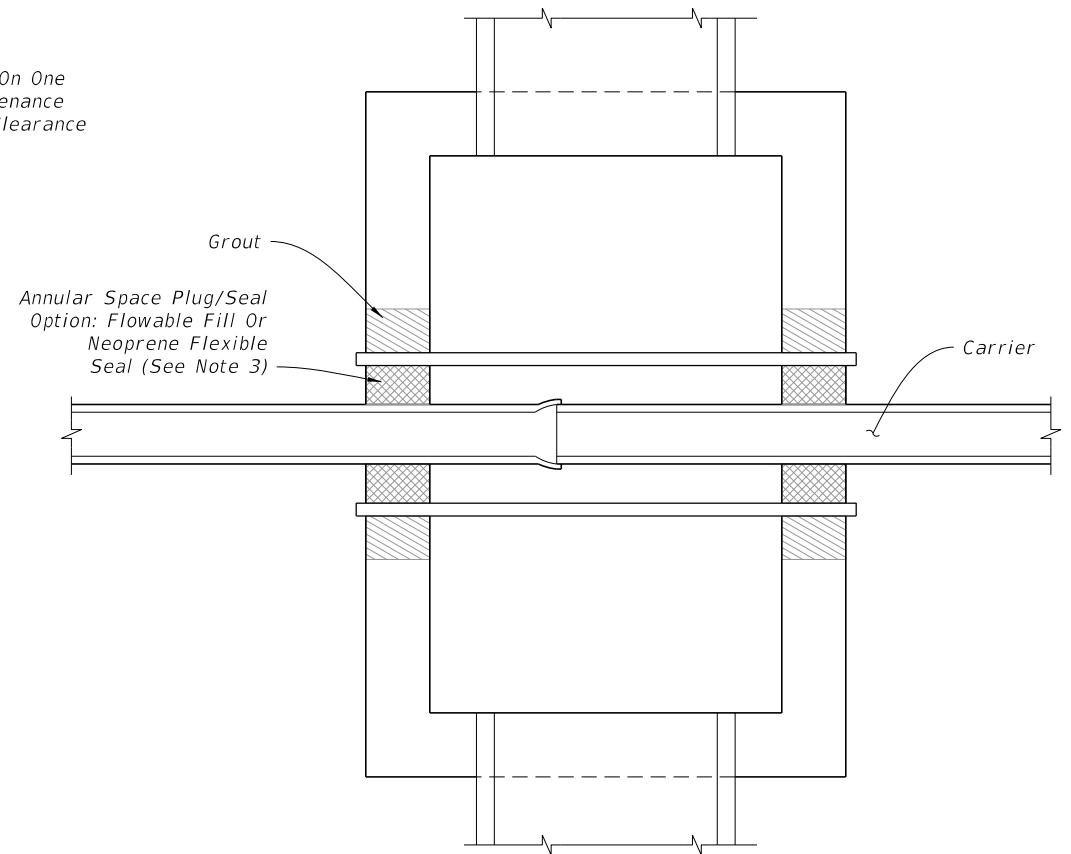

SECTION B-B

UTILITY CONFLICT PIPES THRU STORM DRAIN STRUCTURES

10/14/2019 9:16:47 AM

LAST REVISION 11/01/17	DESCRIPTION:	 FY 2020-21 STANDARD PLANS	UTILITY CONFLICTS THRU DRAINAGE STRUCTURES	INDEX 425-080	SHEET 1 of 1
---------------------------	--------------	---	--	------------------	-----------------