

(TYPE F SHOWN, TYPE G SIMILAR)  
PIPE OPENING SCHEMATIC

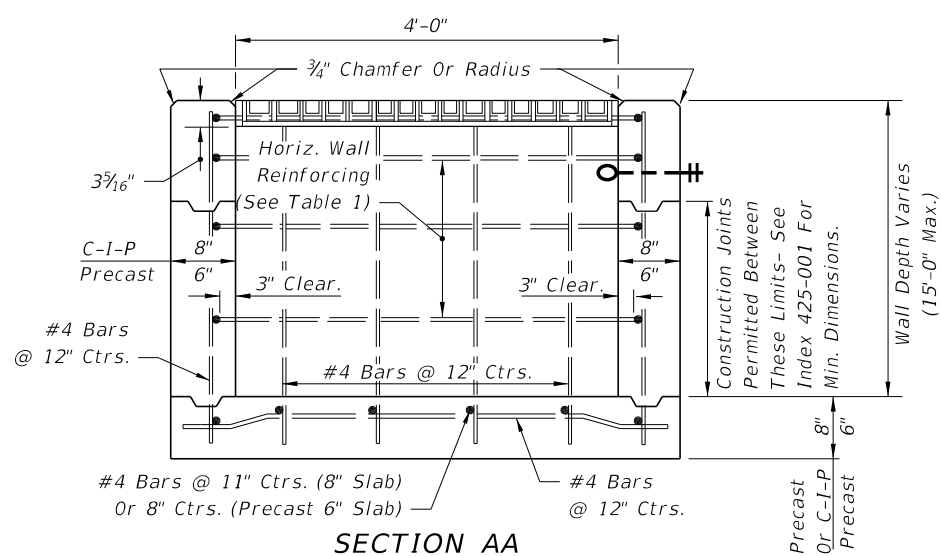

SECTION AA

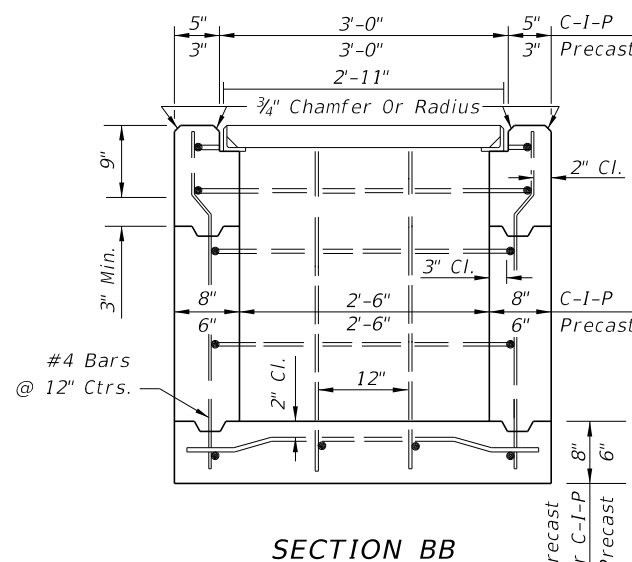

SECTION BB

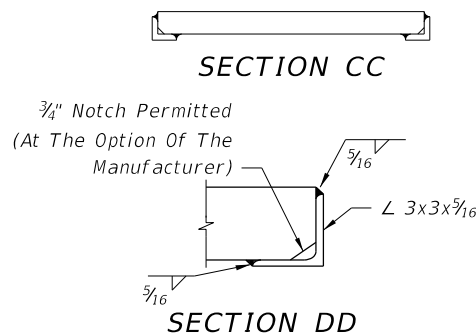

HORIZONTAL WALL REINF. SCHEDULES  
TYPE F INLET (TABLE 1)

WALL DEPTH	SCHEDULE	AREA (in <sup>2</sup> /ft)	MAX. SPACING	
			BARS	WWR
0' - 4'	A12	0.20	12"	8"
4' - 7'	A6	0.20	6"	5"
7' - 12'	B5.5	0.24	5 1/2"	5"
12' - 15'	Special 1	0.267	5"	4"

GENERAL NOTES

1. These inlets are designed for use in ditches, medians, pavement areas, or other areas subject to heavy wheel loads, minimal debris, and bicycle traffic. This inlet may be placed in areas subject to occasional pedestrian traffic such as landscaped areas and pavement areas where pedestrians can walk around the inlet. When inlet is placed in areas subject to bicycle traffic, install filler bar when clearance or gap is greater than 5/8" as shown in Index 425-031.
2. When Alternate G grate is specified in plans, the grate is to be hot dip galvanized after fabrication.
3. These inlets may be used with Alternate B structure bottoms, Index 425-010. The inlet and bottom combinations are to be paid for under the contract unit price for inlets (DT Bot) (Type F (or G)) (J Bot, Depth), Ea.
4. All exposed edges and corners shall be 3/4" chamfer or tooled to 1/4" radius.
5. For supplemental details, see Index 425-001.
6. All reinforcing is Grade 60 bars with 2" min. cover unless otherwise noted. Bars to be cut or bent for 1 1/2" clearance around pipe opening. Provide one additional #4 bar above and at each side of pipe opening, as shown.
7. All dimensions are for both precast and cast-in-place inlets unless otherwise noted.

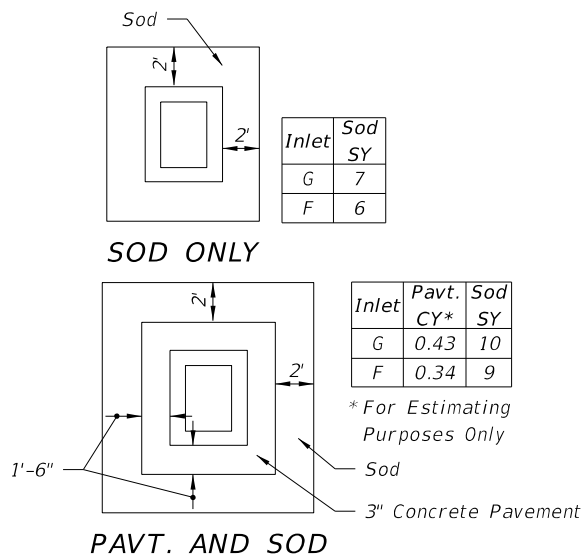

- Notes:
1. Pavement and/or sod to be used only where called for in the plans.
  2. Cost of paving to be included in cost of inlet.

PAVEMENT AND SODDING

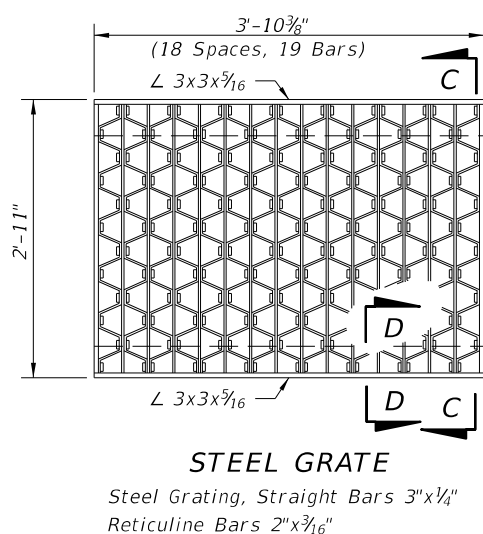

TYPE F

INLET INSIDE WIDTH	PIPE SIZE
2'-6" (Type F)	18"
4'-0" (Type F)	30"
4'-10" / 5'-0" (Type G)	42"

Note: Recommended sizes are for concrete pipe. Sizes for other types of pipe must be verified for fit in accordance with Index 425-001. For larger pipe sizes see Note 3.

10/14/2019 9:13:54 AM

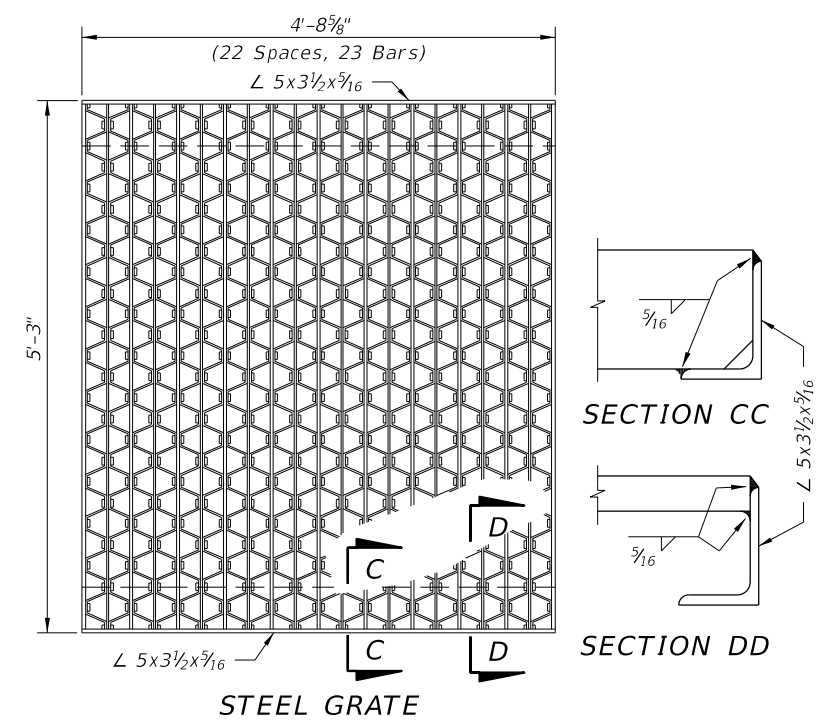
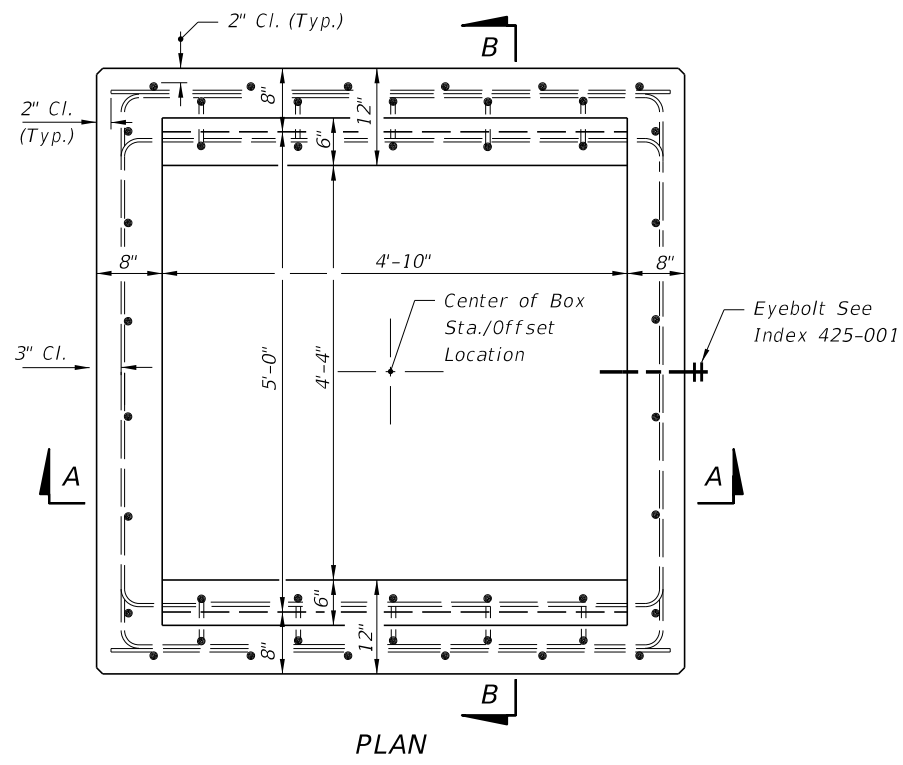

TYPE G INLET (TABLE 2)

WALL DEPTH	SCHEDULE	AREA (in <sup>2</sup> /ft)	MAX. SPACING	
			BARS	WWR
0' - 3'	A12	0.20	12"	8"
3' - 7'	A6	0.20	6"	5"
7' - 10'	B5.5	0.24	5 1/2"	5"
10' - 15'	C6.5	0.37	6 1/2"	6"

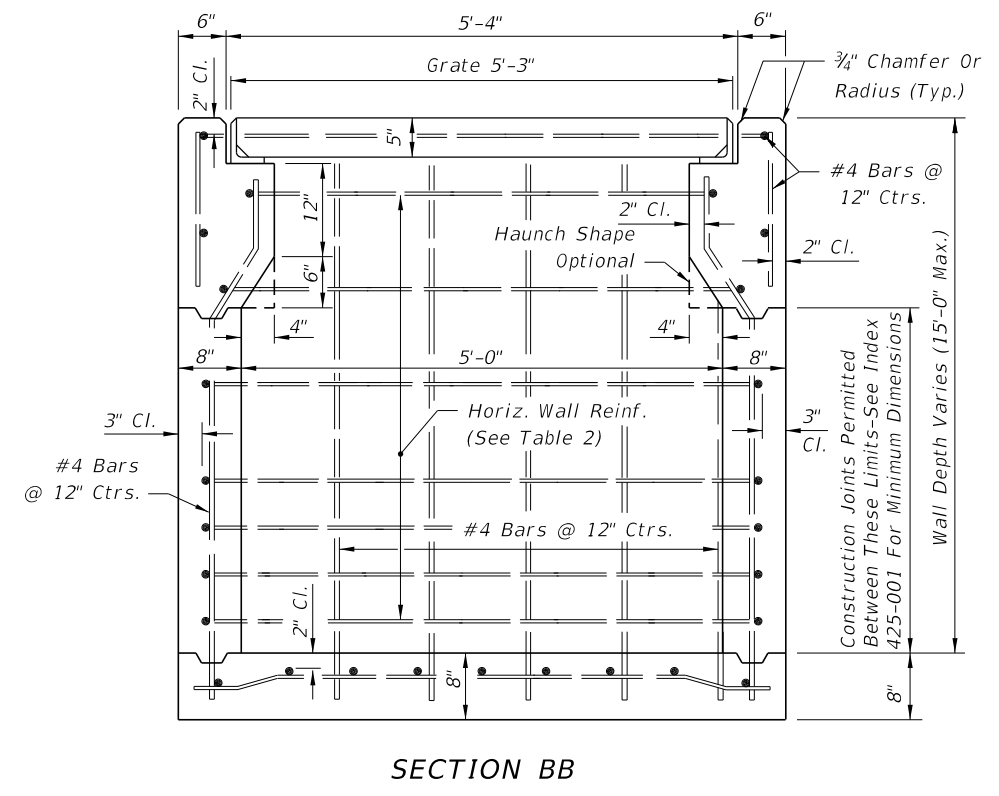
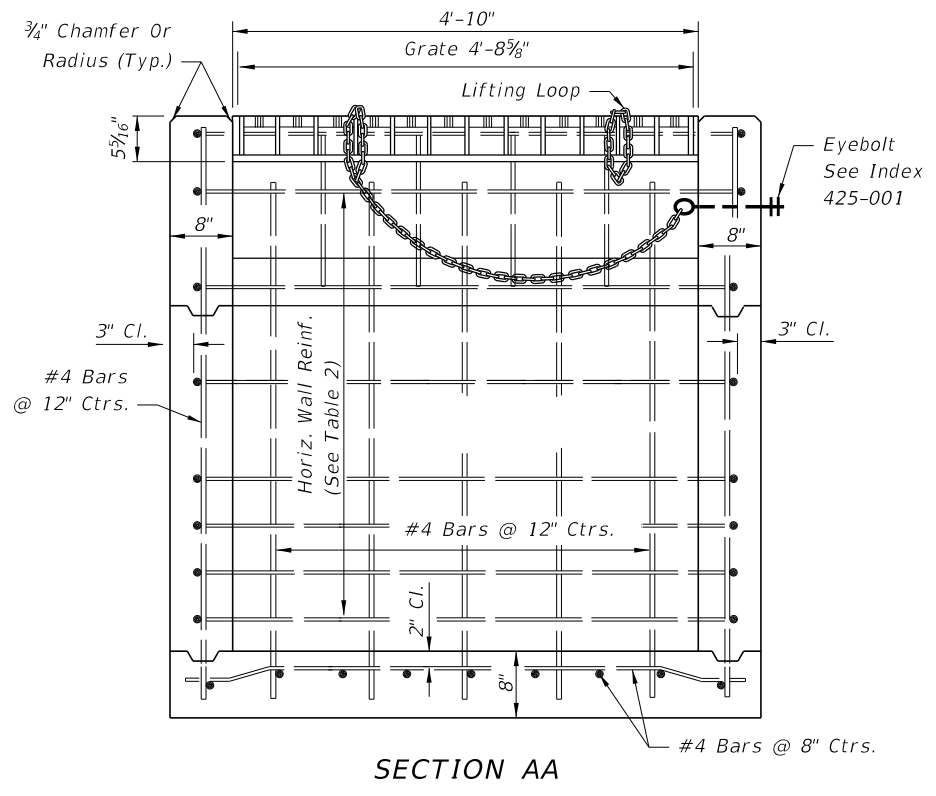

TYPE G

10/14/2019 9:13:55 AM