

△ Construct Expansion Joints Parallel To The Existing Transverse Pavement Joints On Rehabilitation Projects, And Parallel To The Standard Transverse Pavement Joints Shown In The Plans For New Construction.

PLAN

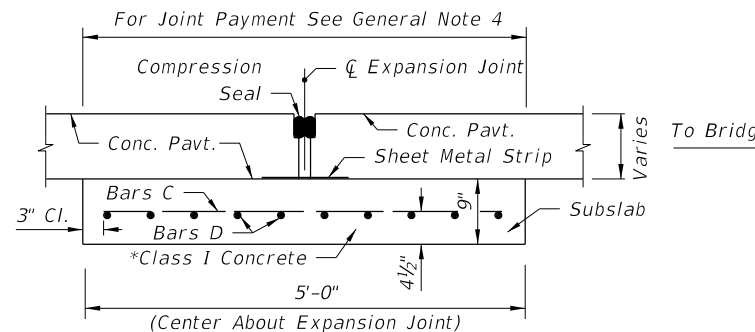

REINFORCING STEEL				
Mark	Size	Spac.	No. Reqd.	Length
C	5	6"	Varies	4'-6"
D	5	6"	10	W Minus 6"

* Finish surface smooth. Cure with heavy coating of wax base white pigmented curing compound. Apply second application immediately prior to placing pavement.

SECTION A-A

GENERAL NOTES:

1. For asphalt base, use four expansion joints per Index 350-001.
2. The centerline of roadway and the centerline of bridge do not necessarily coincide. Determine the centerline of the roadway pavement prior to the placement of the expansion joint.
3. For information on other types of concrete pavement joints see Index 350-001.
4. Pay quantity for expansion joint is the length of joint to be constructed across the roadway and shoulder pavements, measured at right angles to the centerline of the roadway. Payment for expansion joint is full compensation for joint construction, including reinforced concrete subslab, sheet metal strip and compression seal, but, not including roadway pavement reconstruction associated with joint replacement or reconstruction. Expansion joint to be paid for under the contract unit price for Bridge Approach Expansion Joint, LF.

EXPANSION JOINT

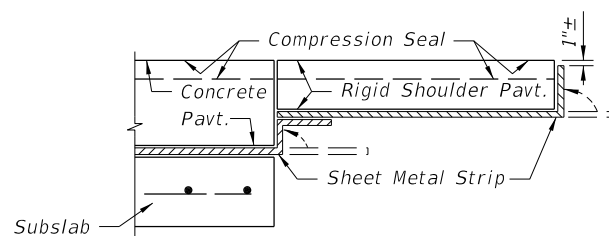

RIGID SHOULDER PAVEMENT

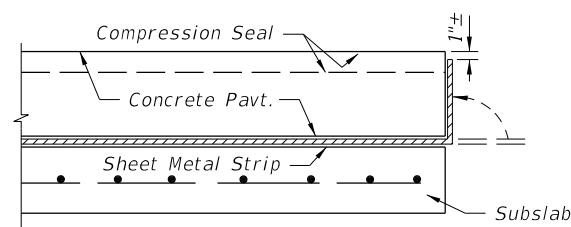

SODDED SHOULDER OR FLEXIBLE SHOULDER PAVEMENT

NOTES:

1. Immediately prior to placing the seal, thoroughly clean the joint of all foreign material. Immediately after the seal is placed, bend up the sheet metal strip against the pavement edge.
2. Use a minimum 16 gage steel, 12" wide sheet metal strip, Galvanized in accordance with ASTM A-526, Coating Designation G90.

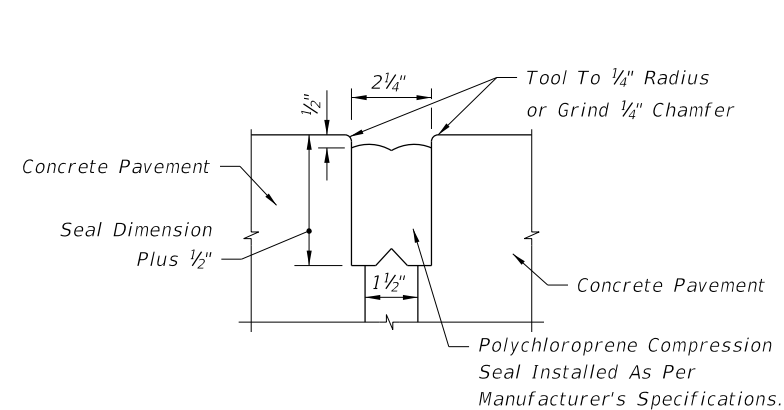

NOTE:

Thoroughly coat all contacting surfaces between the compression seal and concrete with a lubricant-adhesive.

JOINT DIMENSIONS

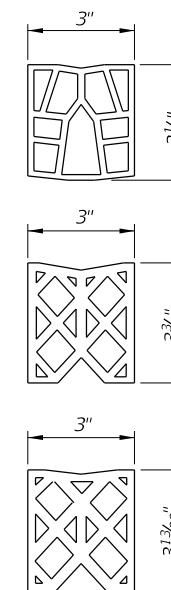

OPTIONAL SEALS

SHEET METAL STRIP DETAILS

COMPRESSION SEAL DETAIL

10/14/2019 9:01:09 AM