

PLAN  
TIMBER PLATE

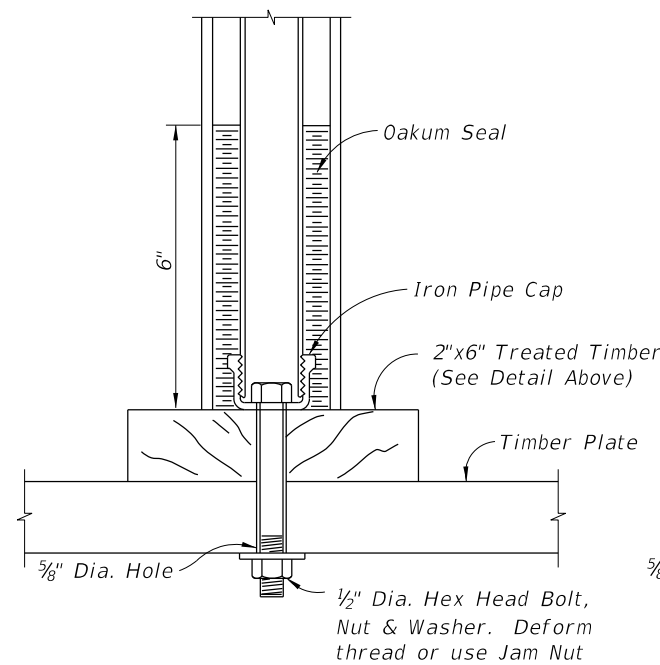

TIMBER PLATE

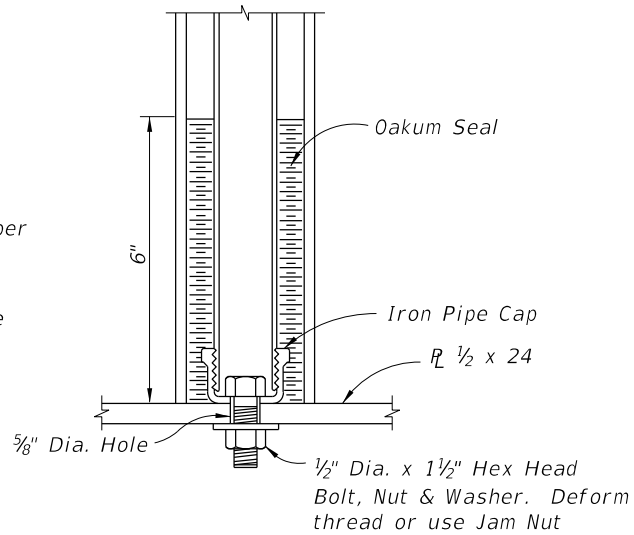
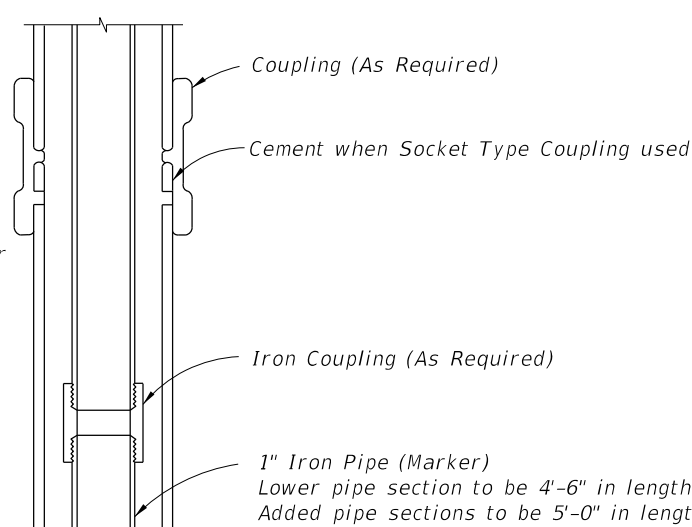
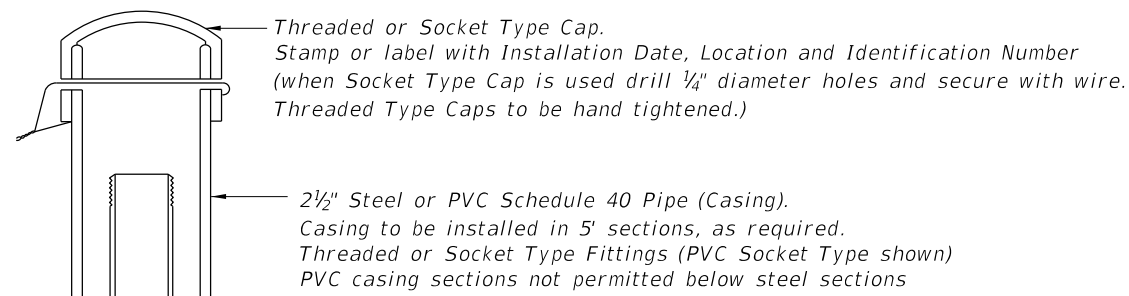

STEEL PLATE

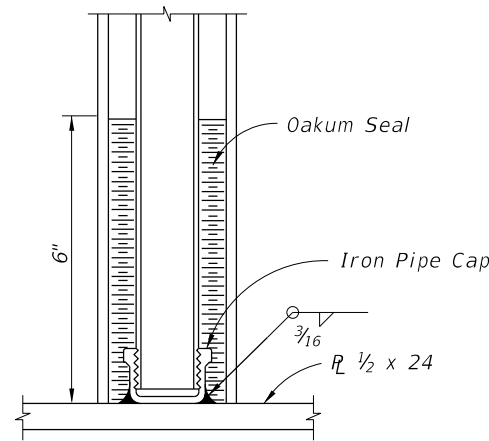

STEEL PLATE

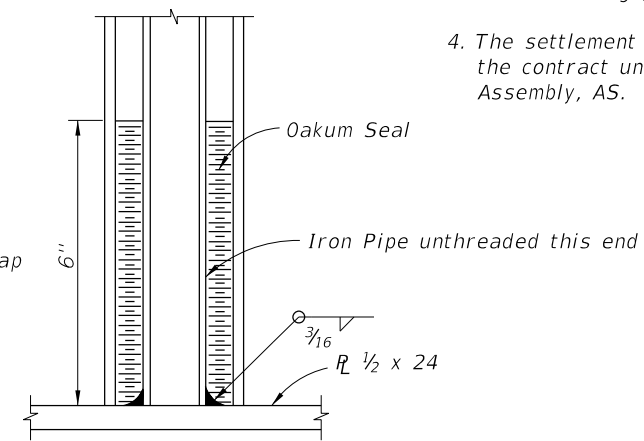

STEEL PLATE

STEM AND PLATE OPTIONS

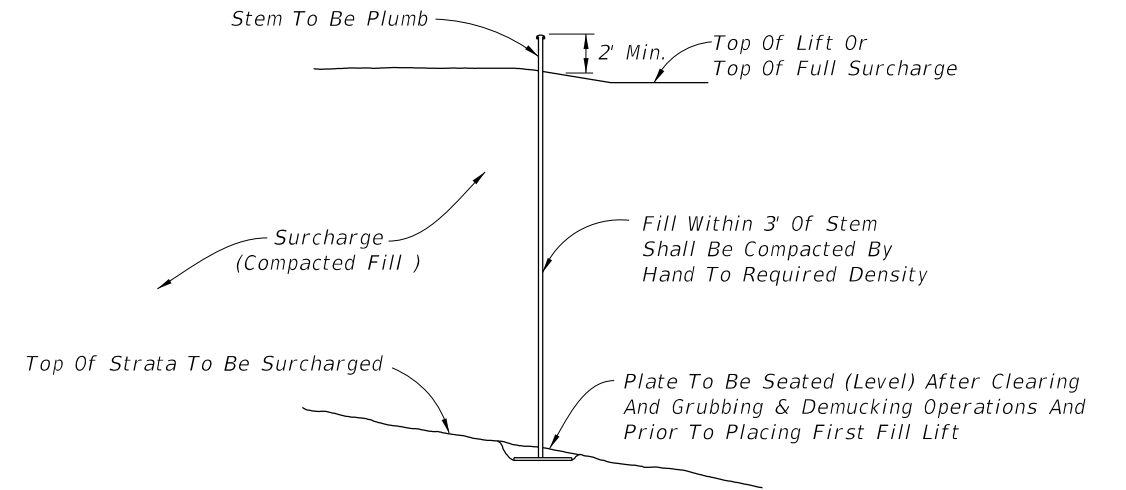

INSTALLATION

NOTES:

1. Elevation of the top of each length of marker pipe shall be determined as soon as it is installed and also immediately before the next length of marker pipe is added.
2. Settlement plate locations shall be flagged and protected from construction vehicles and equipment. If settlement plates are disturbed, they shall be replaced in kind.
3. Oakum used to construct seal should not have a mesh covering (plastic or other synthetic material).
4. The settlement plates shall be paid for under the contract unit price for Settlement Plate Assembly, AS.

10/14/2019 8:57:57 AM

LAST REVISION 01/01/00	REVISION	DESCRIPTION:
---------------------------	----------	--------------



FY 2020-21  
STANDARD PLANS

SETTLEMENT PLATE

INDEX  
141-T01

SHEET  
1 of 1