

VIEW A-A
(Shear key shown dashed)

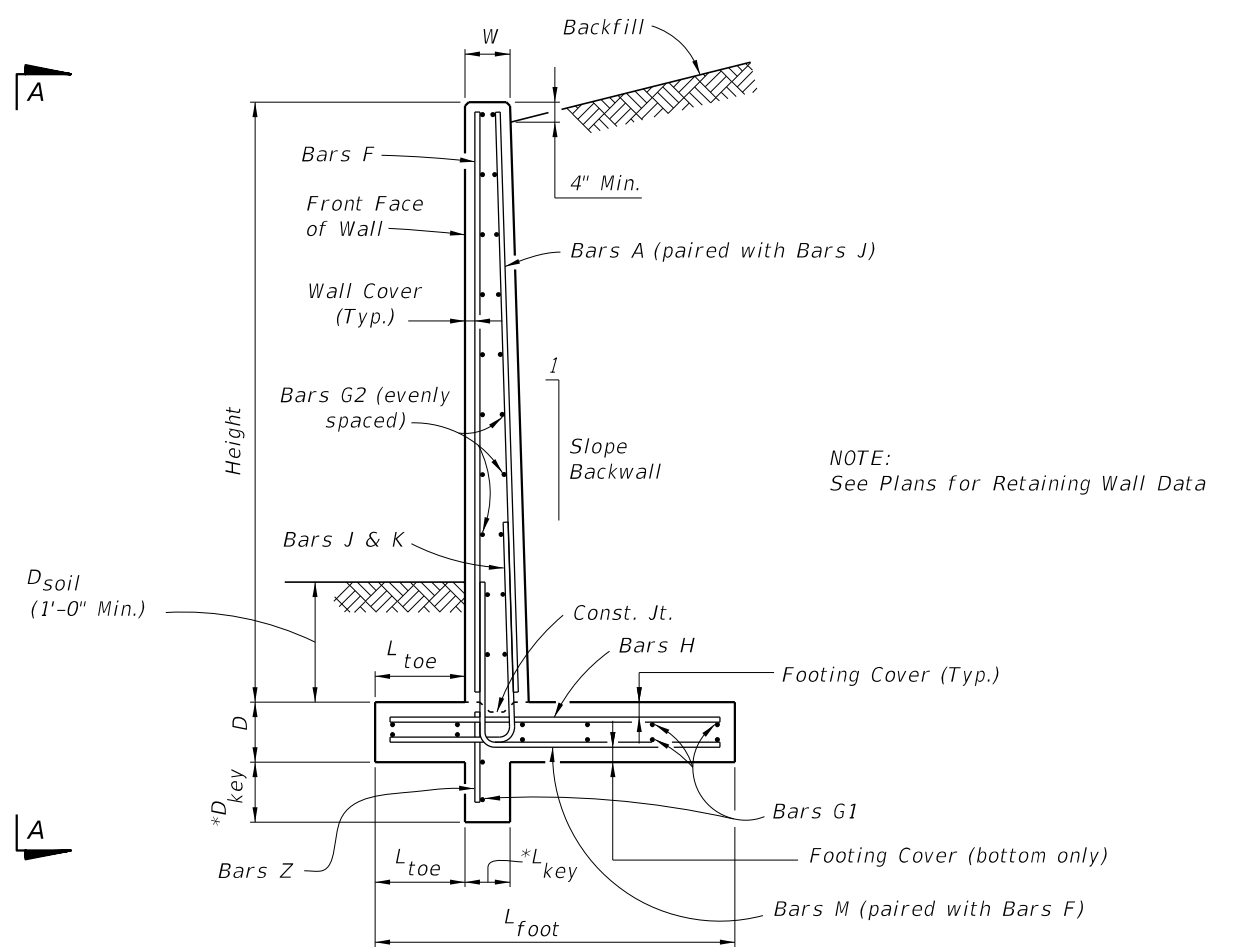

* Shear Key is required only when specified in the Plans.

TYPICAL SECTION

NOTES

TRAFFIC RAILINGS OR PARAPETS:
If there is a Traffic Railing or Parapet on the wall, align Wall Joints with V-Grooves, and Wall Expansion Joints with Barrier Open Joints.

FOUNDATION: Prepare the soil below the footing in accordance with the requirements for spread footings in Specification Section 455.

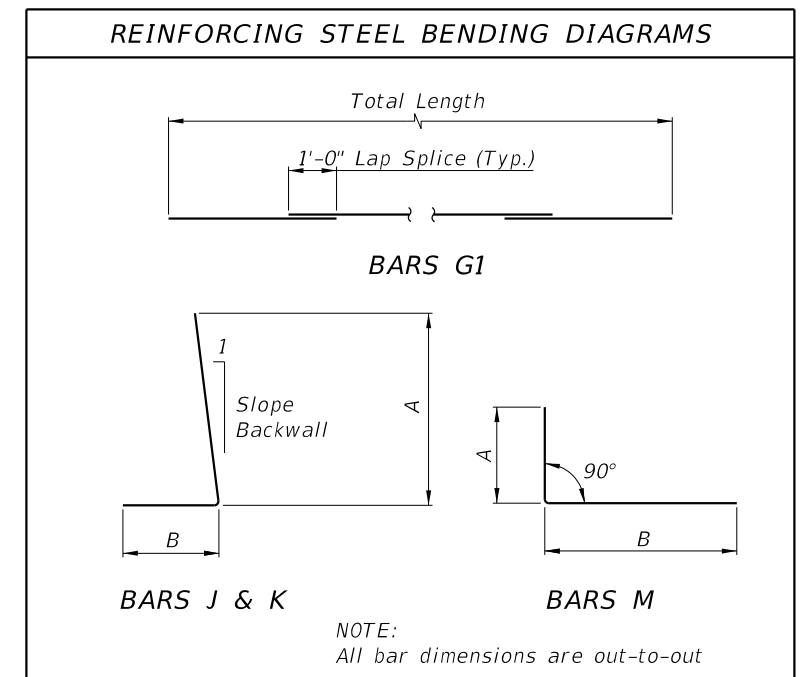

10/30/2018 8:42:19 AM

LAST REVISION 11/01/17	REVISION	DESCRIPTION:	 FY 2019-20 STANDARD PLANS	CANTILEVER RETAINING WALL (C-I-P)	INDEX 400-010	SHEET 1 of 2
---------------------------	----------	--------------	-------------------------------------------------------------------------------------------------------------------------------	------------------------------------------	-------------------------	------------------------

**Wall joint spacing 25 ft. maximum and 5' minimum. At minimum, every fourth wall joint to be an expansion joint. See Plans for actual wall joint spacing and expansion joint location.

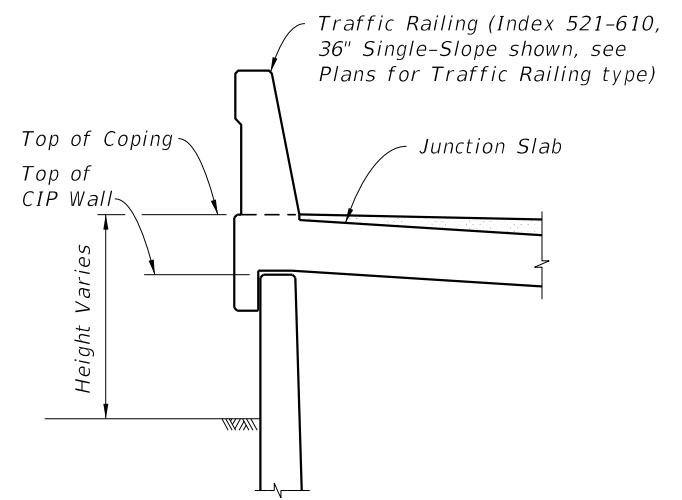
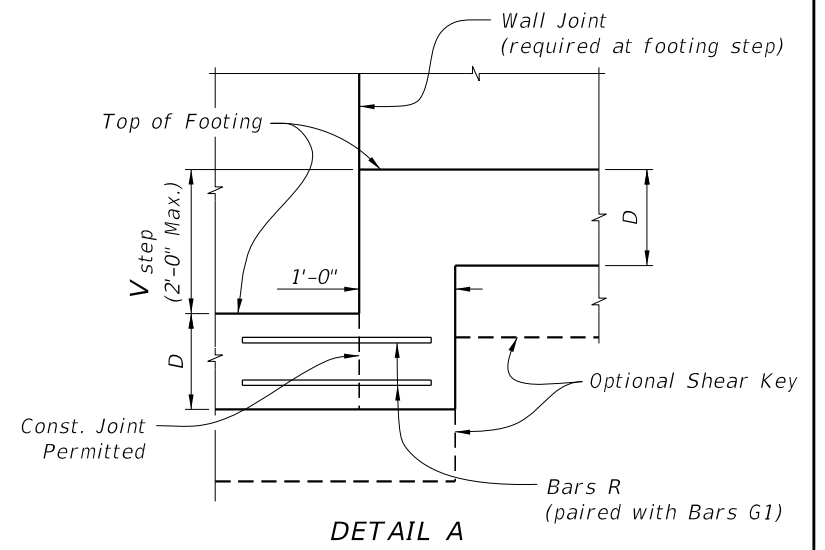
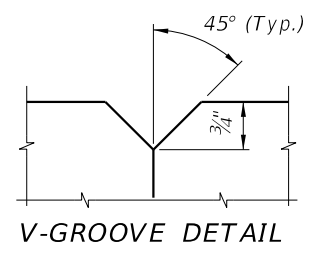
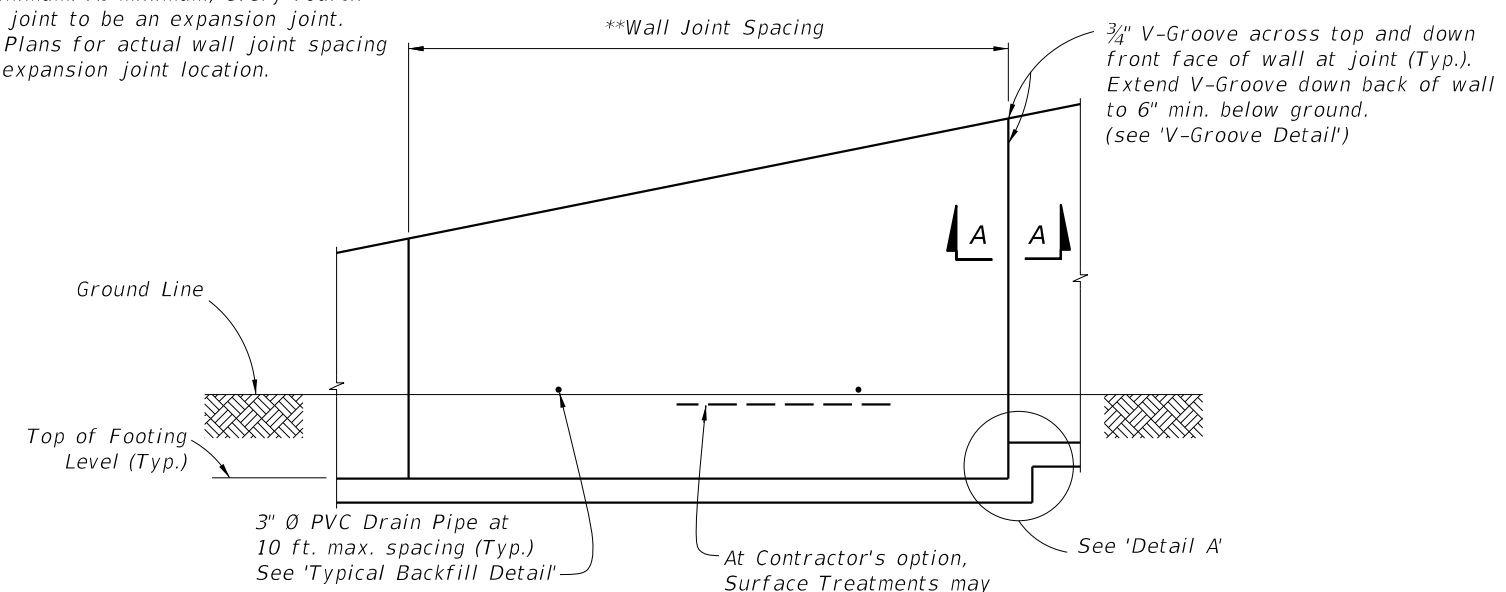

FRONT ELEVATION

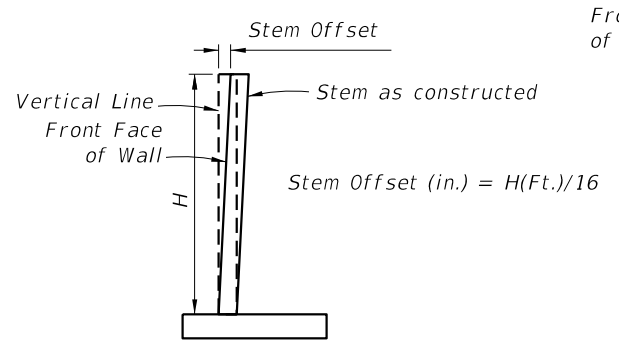

STEM OFFSET VALUES
(for H < 20 Ft.)

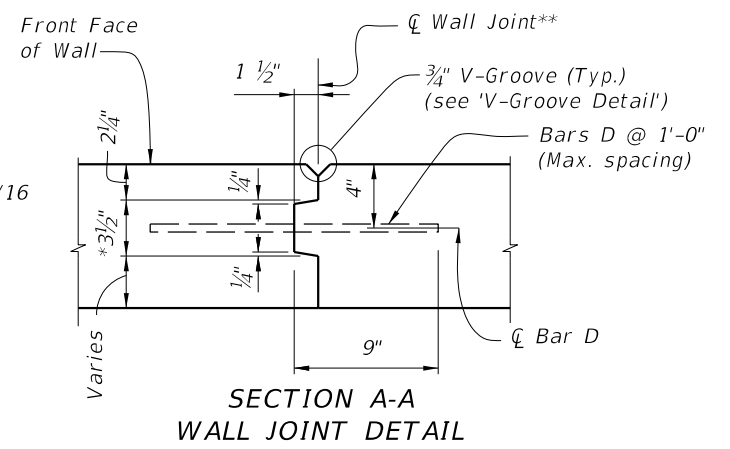

SECTION A-A WALL JOINT DETAIL

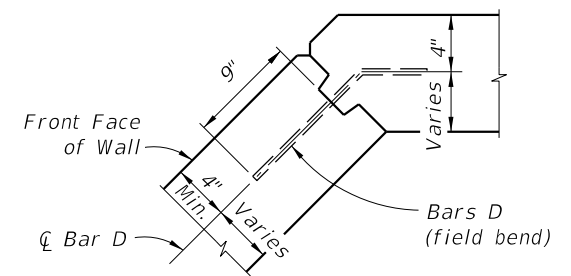

TYPICAL CORNER JOINT DETAIL

TRAFFIC RAILING/JUNCTION SLAB DETAIL
(36" Single-Slope shown, other Traffic Railings similar)

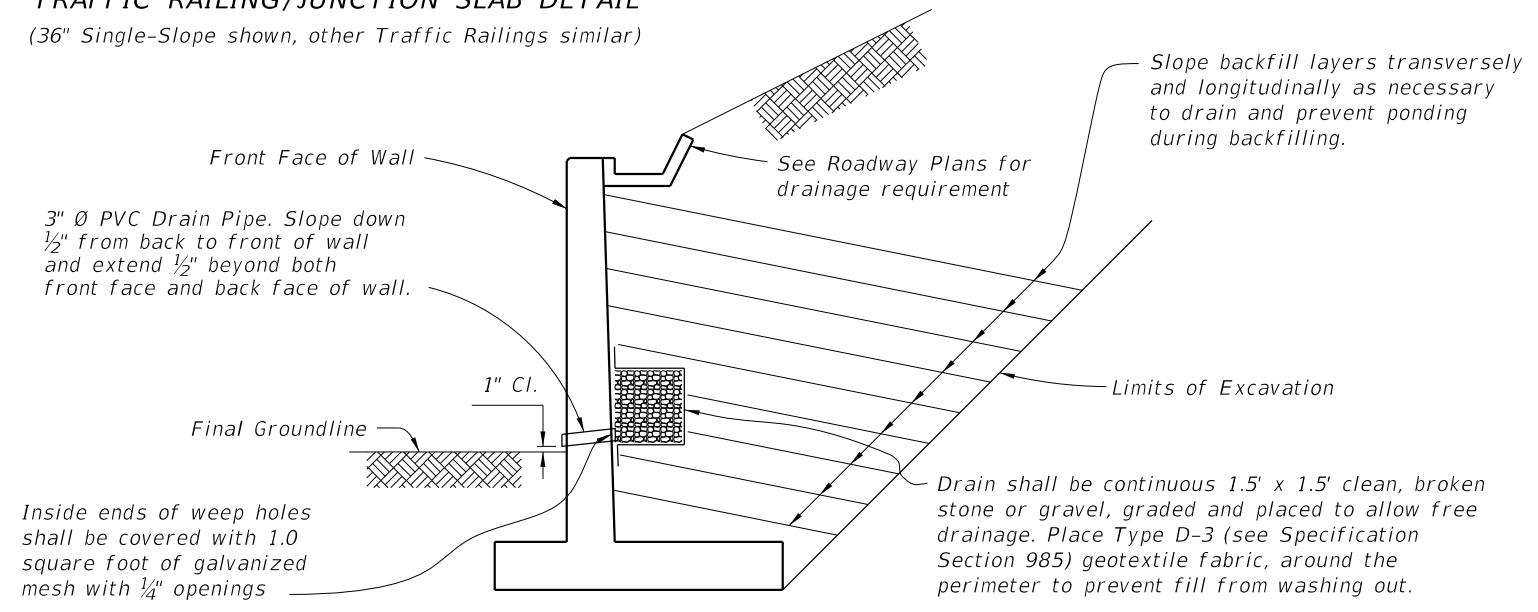

TYPICAL BACKFILL DETAIL

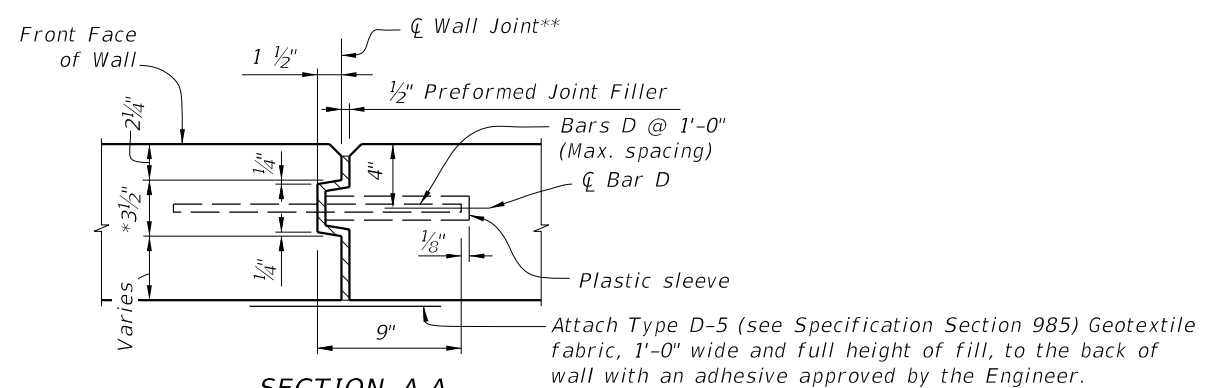

SECTION A-A EXPANSION JOINT DETAIL

* Key to stop at top of footing and 6" from top of wall. Joint across footing and top of wall to be a straight line.

** Stay-In-Place Plastic Preformed Bond Beakers are permitted to form joints.

10/30/2018 8:42:22 AM

LAST REVISION 11/01/17	DESCRIPTION:	 FY 2019-20 STANDARD PLANS	CANTILEVER RETAINING WALL (C-I-P)	INDEX 400-010	SHEET 2 of 2
---------------------------	--------------	------------------------------------------------------------------------------------------------------------------------------	------------------------------------------	-------------------------	------------------------

GENERAL NOTES

- C-I-P Gravity Walls constructed as extensions of reinforced concrete retaining walls, except walls of proprietary designs, shall have the same face texture and finish as the reinforced concrete retaining wall.
- Concrete for Gravity Wall shall be Class NS per Section 347. Concrete for Scheme 3 Junction Slab and Traffic Railing shall be Class II per Section 346, unless otherwise specified in the plans.
- Reinforcing steel shall meet the requirements of Specification Section 931 (Grade 40 or 60). Smooth or Deformed Welded Wire Reinforcement (WWR) may be substituted on an equal area basis. Do not increase bar/wire spacing for Grade 60 reinforcing steel or WWR.
- When required, for adjunct guiderail, see Index 515-070 or 515-080 as appropriate. For adjunct Type B fence see Index 550-002.
- Joint Seal: Organic Felt bond breaker in accordance with Specification Section 400 or Type D-5 geotextile fabric in accordance with Specification Section 985. Mop all contact surfaces of concrete and Organic Felt or geotextile fabric with cut-back asphalt. Stop Organic Felt or geotextile fabric 6" below top of wall.
- Provide a continuous 1'x1' clean gravel or crushed rock drain for wall heights 3 ft. and higher. Wrap drainage layer as shown, with Type D-3 geotextile fabric in accordance with Specification Section 985. Provide 8"x8" galvanized mesh with 1/4" openings, at the inside end of the PVC Drain Pipe. Provide 2" Ø PVC Drain Pipe (Sch. 40) at 10 ft. max. spacing (when Drainage Layer is required). Locate outermost edge of Drain Pipe a minimum of 2'-0" from wall joints.
- Cost of reinforcing steel, face texture, finish, joint seal, drain pipes, drainage layer, galvanized mesh and geotextile fabric to be included in the Contract Unit Price for Concrete Class NS, Gravity Wall. Cost of concrete for Junction Slab in Scheme 3, to be included in Contract Unit Price for Concrete Traffic Railing Barrier With Junction Slab. Adjunct railings or fences to be paid for separately.

ESTIMATED QUANTITIES FOR C-I-P WALL					
HEIGHT (FT.)	PER LINEAR FOOT OF WALL			REINF. STEEL (LB.)	WEEP HOLES & DRAIN REQD.
	CLASS NS CONCRETE (CY)				
	SCHEME 1	SCHEME 2	SCHEME 3**		
1'	0.08	0.11 (0.20*)	0.03	3 (4*)	No
2'	0.14	0.20 (0.32*)	0.09	4 (5*)	No
3'	0.22	0.32 (0.47*)	0.29	5 (6*)	Yes
4'	0.32 (0.43*)	0.47 (0.65*)	0.43	6 (7*)	Yes
5'	0.43 (0.55*)	0.65 (0.85*)	0.60	7 (8*)	Yes

ESTIMATED QUANTITIES NOTES:
 For Scheme 3 Junction Slab and Traffic Railing see the referenced Index for estimated quantities.
 * Quantity for 2'-0" Toe Depth.
 ** Quantity for Scheme 3 assumes 1'-3" thick coping above Gravity Wall.

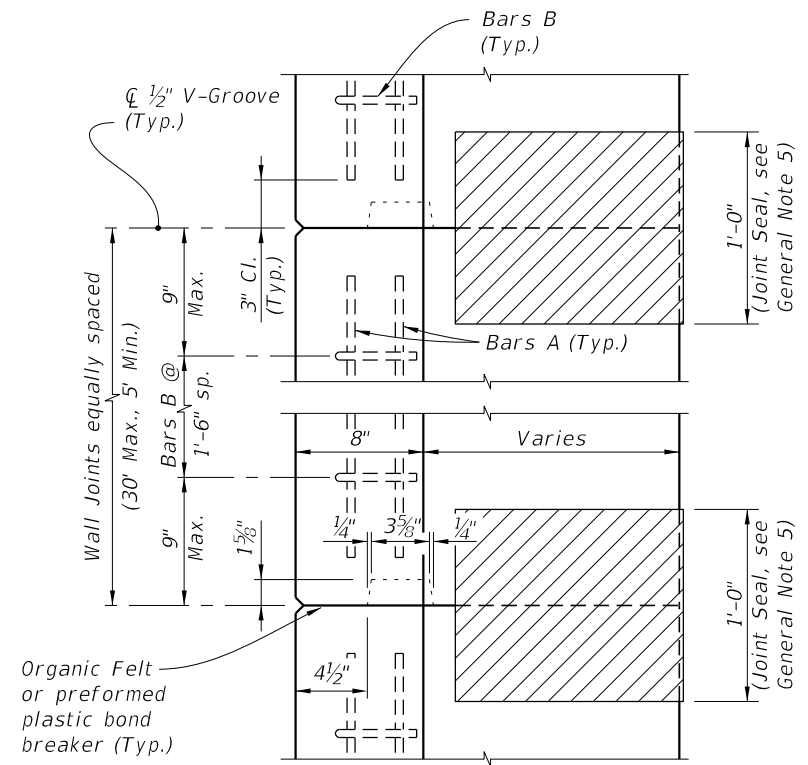

KEYWAY & WALL JOINT DETAIL (TOP VIEW)

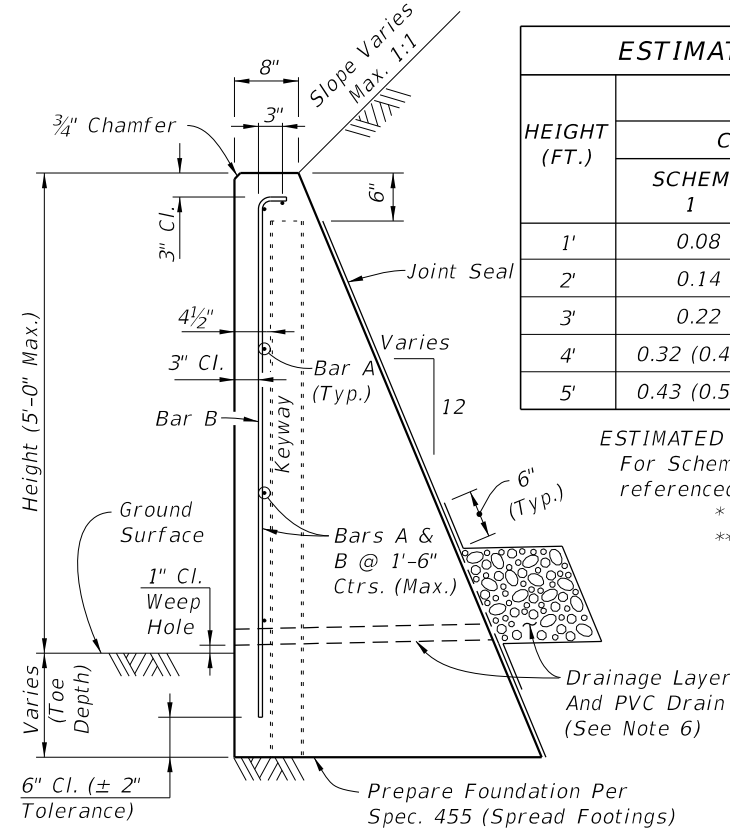

TYPICAL SECTION C-I-P CONCRETE GRAVITY WALL

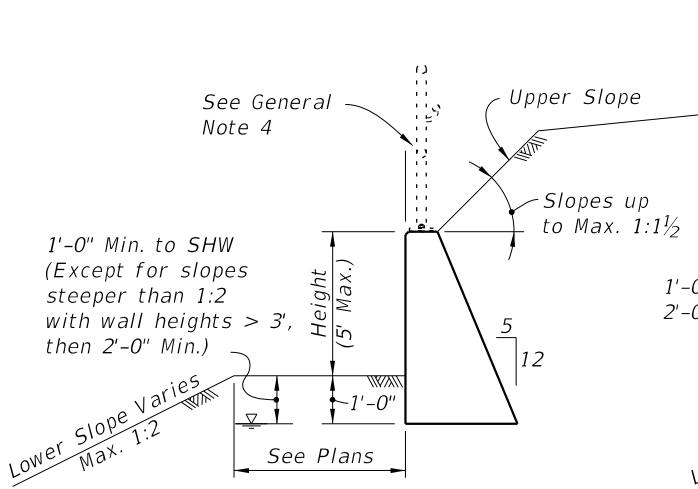

SCHEME 1 (No Traffic Loading Effects & Upper Slopes ≤ 1:1 1/2)

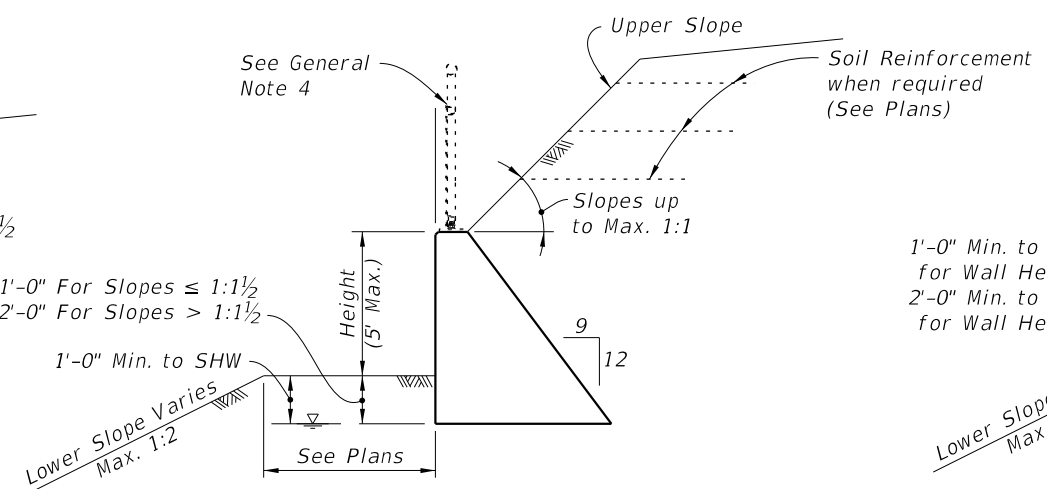

SCHEME 2 (With Traffic Loading or Upper Slopes > 1:1 1/2)

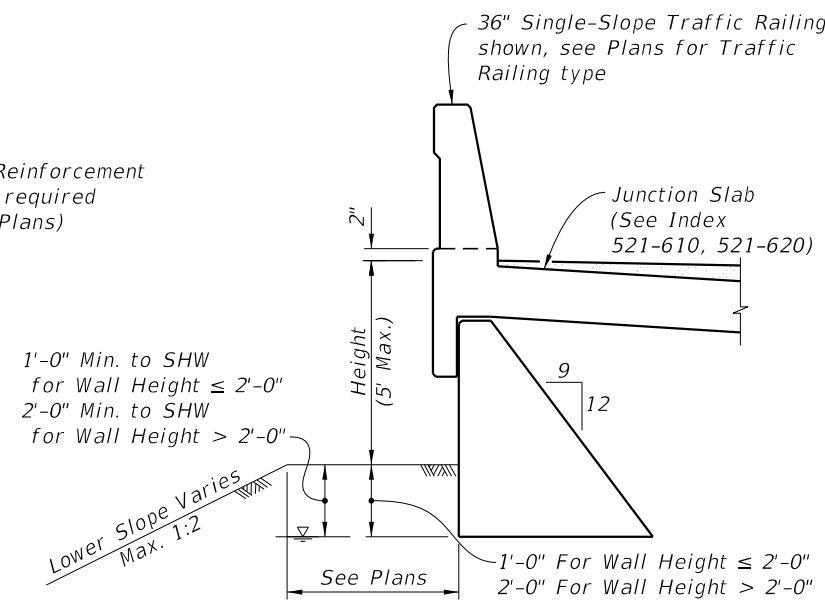

SCHEME 3 (With Traffic Railing)

BILL OF REINFORCING STEEL		
MARK	SIZE	LENGTH
A	4	As Reqd.
B	4	As Reqd.

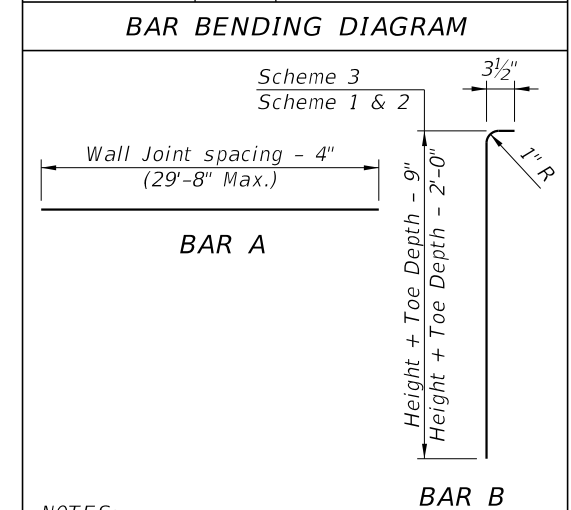

NOTES:
 1. All bar dimensions are out to out.
 2. Lap splices for Bars A must be a minimum of 1'-10".

10/30/2018 8:42:26 AM

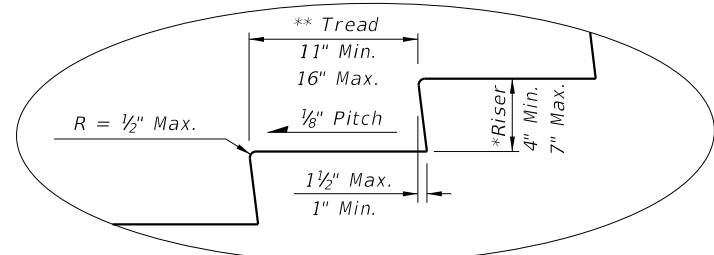

STAIR TREAD AND RISER DETAILS

* The greatest riser height within the flight of steps shall not exceed the smallest by more than 3/8".
 ** The greatest tread depth within the flight of steps shall not exceed the smallest by more than 3/8".

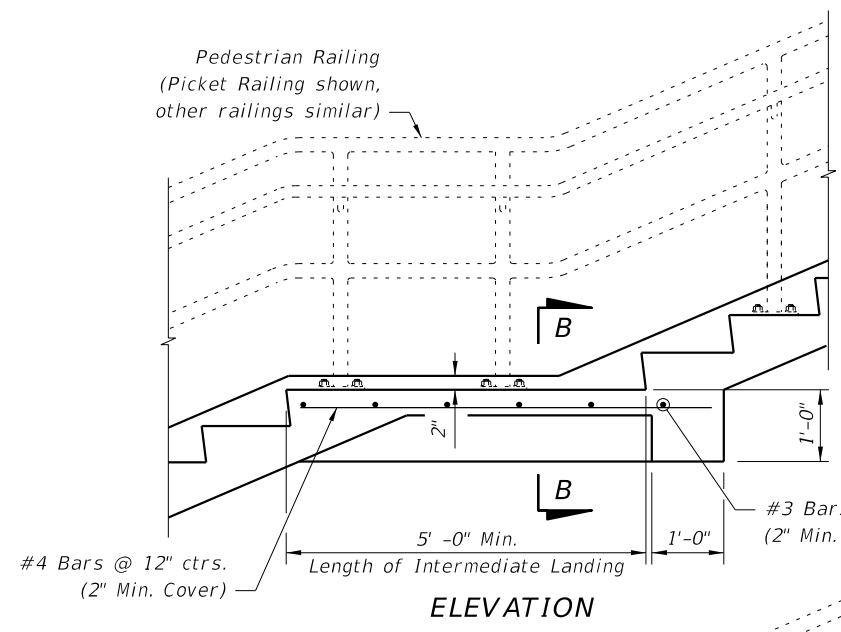

ELEVATION

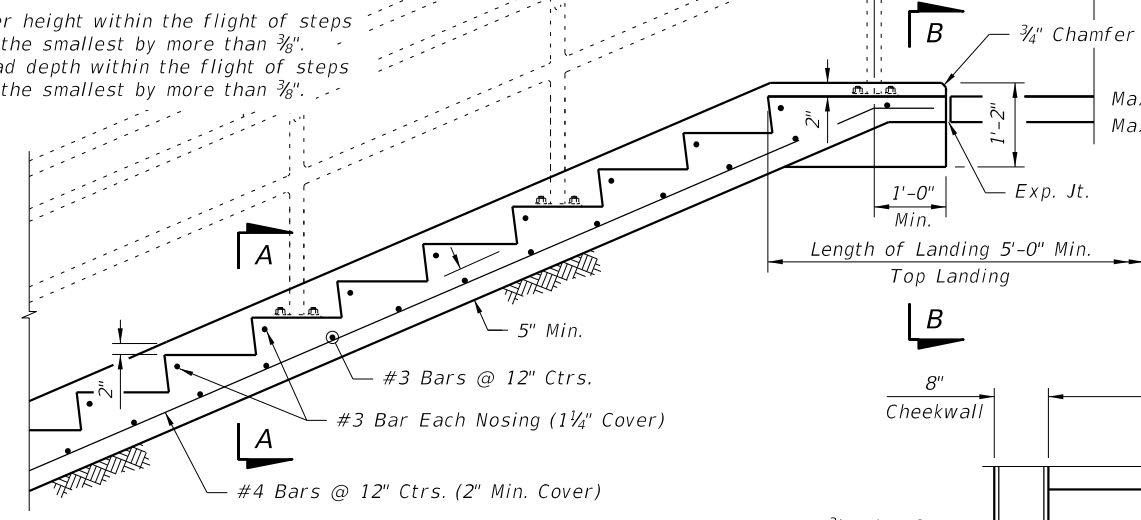

NOTE: Provide a maximum of 12 risers between landings.

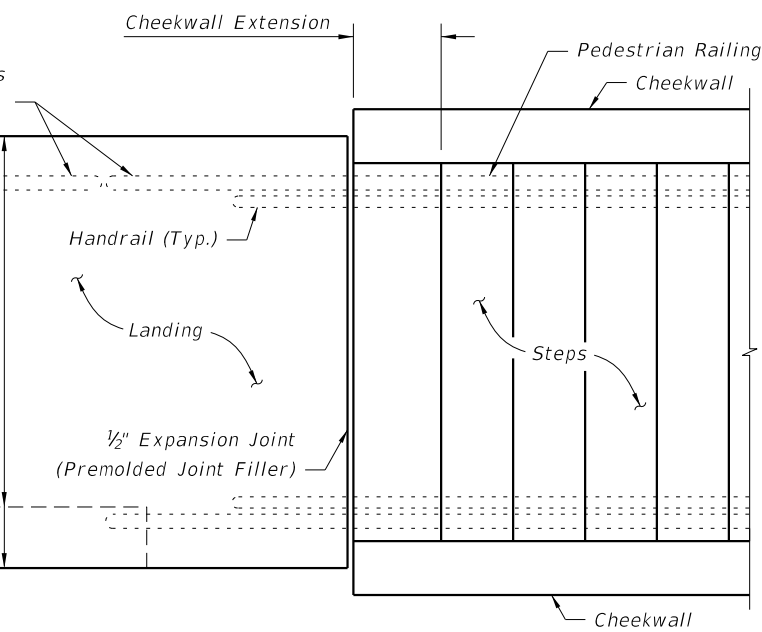
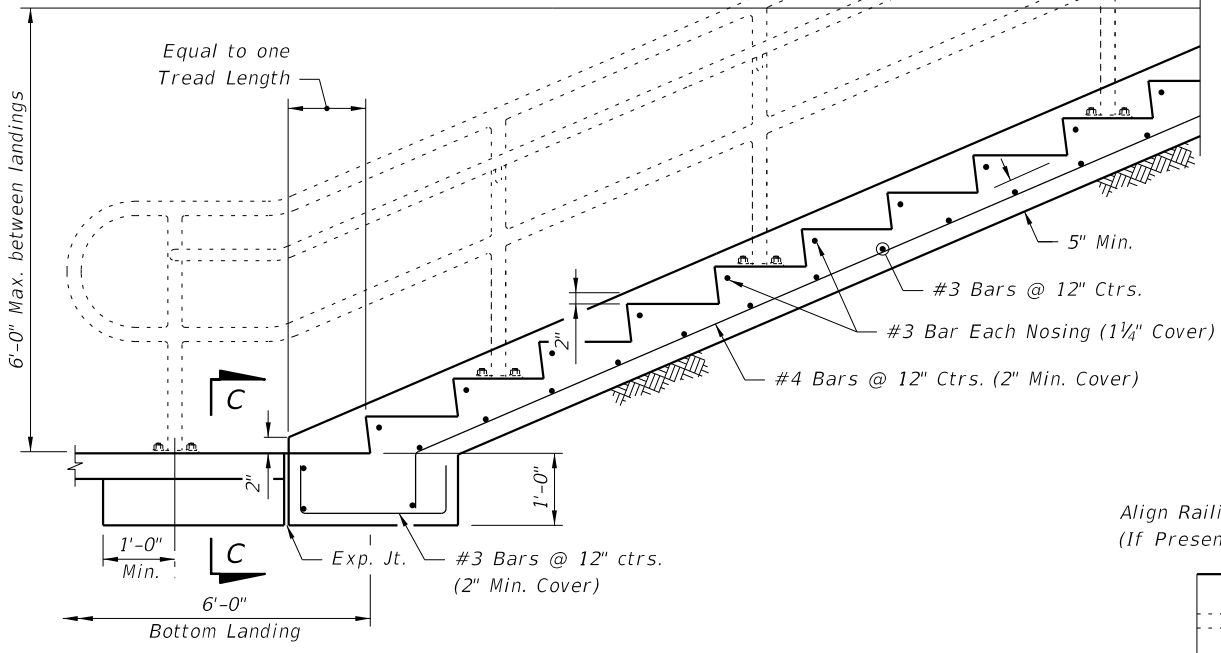

PLAN AT JUNCTION OF STEPS & LANDING
 (Bottom Landing shown, Top Landing similar)

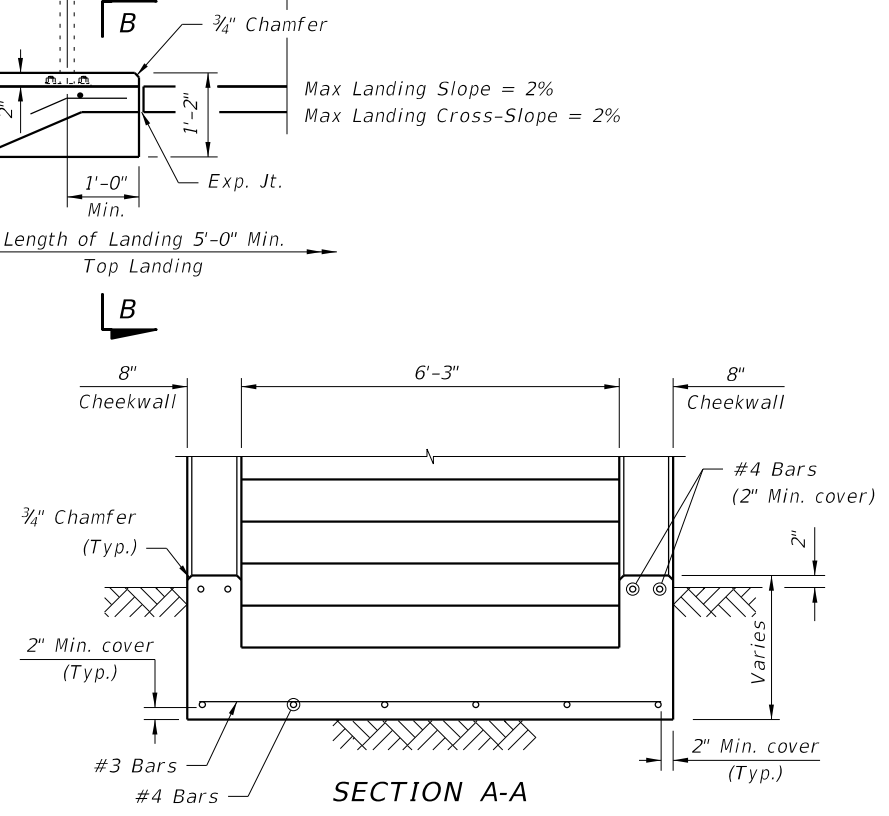

SECTION A-A

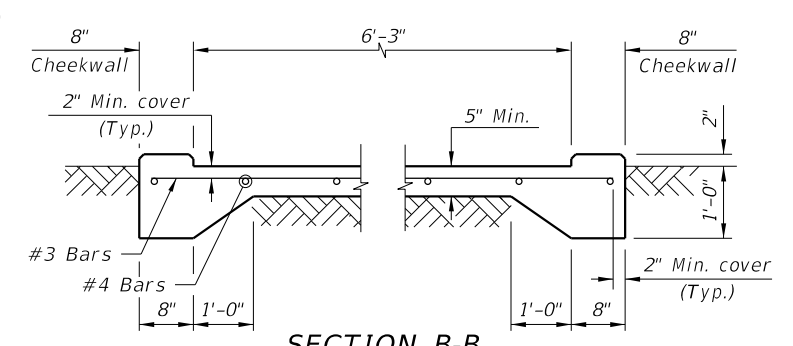

SECTION B-B

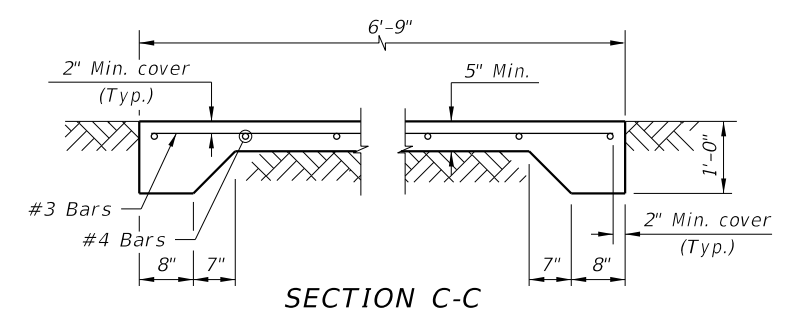

SECTION C-C

Max Landing Slope = 2%
 Max Landing Cross-Slope = 2%

- NOTES:
1. Do not use this Index for suspended (structural) steps or stairways.
 2. Construct steps in accordance with Section 522 of the FDOT Standard Specifications.
 3. Concrete: Class NS, Specification 347.
 4. Tread Finish: Broom finish parallel to steps unless otherwise shown in Plans.
 5. Pedestrian Railing: See Indexes 515-052, 515-062, 515-070, 515-080 or Project Specific Design.
 6. Cost of concrete steps, landings and cheekwalls shall be paid for under the contract unit price for Class NS Concrete (Concrete Steps), CY. Cost of reinforcing steel shall be paid for under the contract unit price for Reinforcing Steel (Miscellaneous), LB.

10/30/2018 8:42:29 AM

LAST REVISION 11/01/17	DESCRIPTION:	 FY 2019-20 STANDARD PLANS	CONCRETE STEPS	INDEX 400-021	SHEET 1 of 1
---------------------------	--------------	----------------------------------	-----------------------	------------------	-----------------

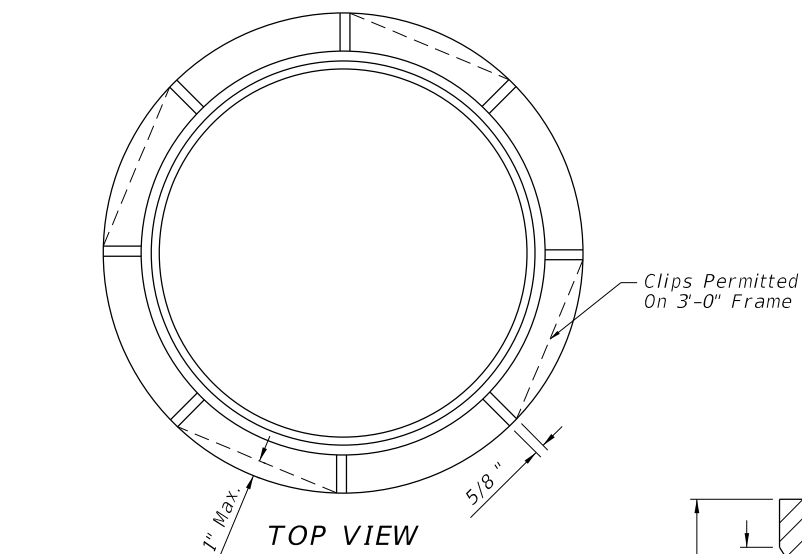

TOP VIEW

Clips Permitted On 3'-0" Frame

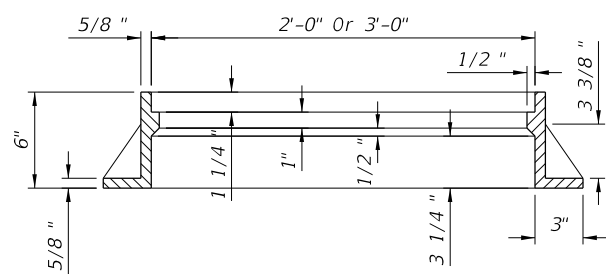

SECTION
For Manholes
TYPE I

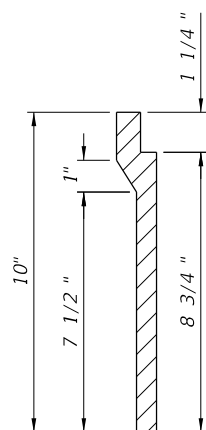

WALL SECTION
For Curb Inlets Types 1, 2, 3, & 4
TYPE II

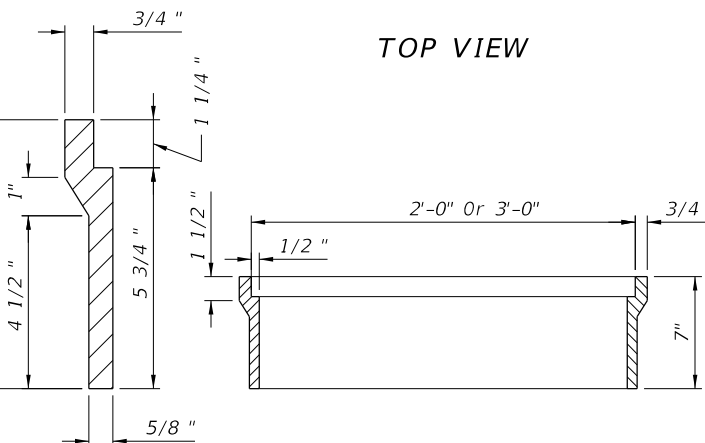
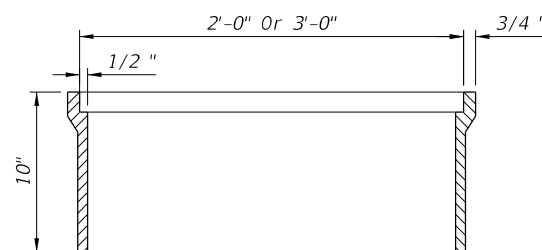

WALL SECTION
For Curb Inlets Types 7 & 8
TYPE III

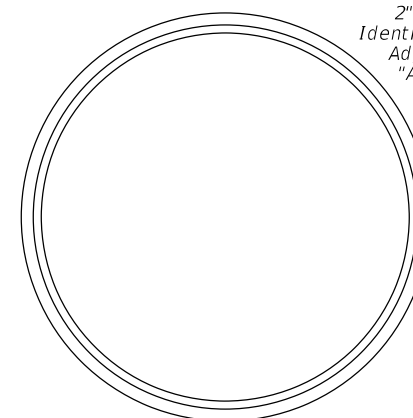

TOP VIEW

2" Raised Or Depressed Identification Letter Type I Adjustable Shall Include "ADJUSTABLE" On Cover

Pick-Up Hole

FDOT
STORM
SEWER

Raised Or Depressed Logo

Nonskid Surface

TOP VIEW

2" Raised Or Depressed Identification Letter

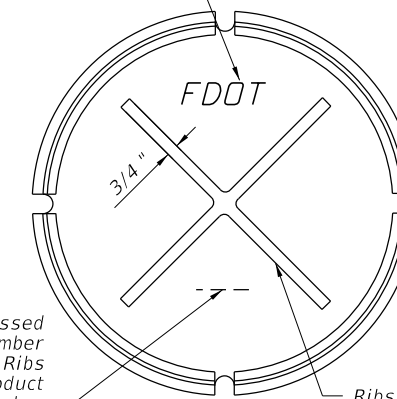

2" Raised Or Depressed Identification Number Covers With And Without Ribs Shall Bear The Same Product Identification Number

Ribs (Optional)

BOTTOM VIEW

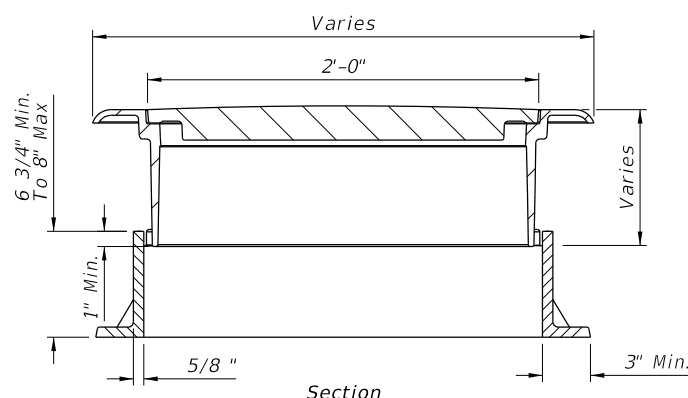

Section

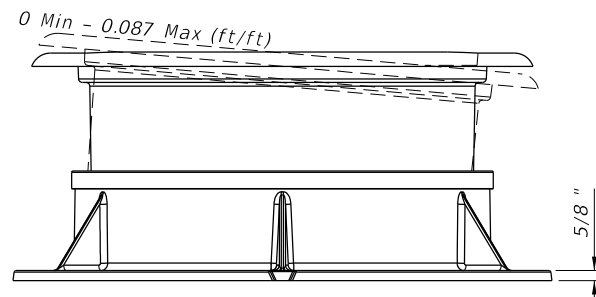

Front View
TYPE I ADJUSTABLE

WEIGHT OF CASTINGS (lb)						
Frame Type	2' OPENING		3' OPENING			
	Frame	Cover (Std.)	Frame	2-Piece Cover		
				Inside	Outside	Total
I *	155	190	220	190	220	410
II	145	190	255	190	220	410
III	90	190	180	190	220	410

* Includes Type I Adjustable

NOTES (FRAMES, AND COVER)

- The standard cover is to be used for all frames Types I, II, III and the 2-piece cover, and is the replacement cover for all previous frames with 1 1/2" deep seats (traffic type). The 185 lb. cover (nontraffic type), 1984 Roadway and Traffic Design Standards Index 201, is the replacement cover for existing frames with 1/2" deep seats. Installation of frame with 1/2" deep seats is not permitted.
- Use the 2'-0" cover, unless the 2-piece cover is called for in the plans, except at inlets and manholes with sump bottoms use the 2-piece cover when the sump depth exceeds 2', unless otherwise noted.

DESIGNER NOTE:

Consider using the 2-piece cover where depths exceed 5' and manual entry may be required for cleaning. Clearly note the requirement for a 2-piece cover, on the Drainage Structure sheets in the plans.

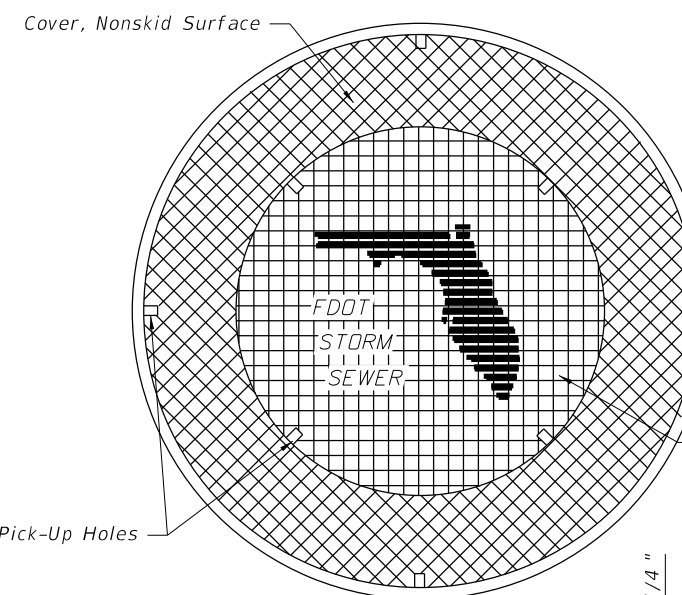

For Use With Types I, II And III Frames With 3'-0" Opening

2-PIECE COVER

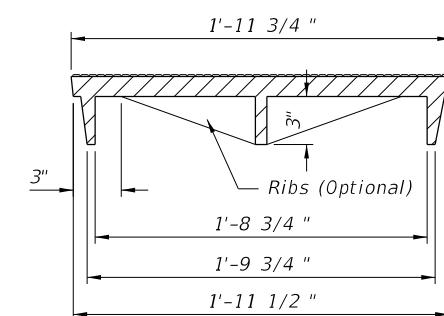

COVER FOR ALL FRAMES

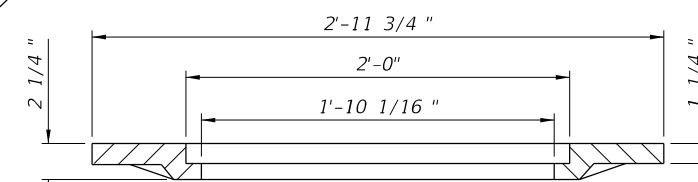

2-PIECE COVER

See General Note 1

10/30/2018 8:42:33 AM

LAST REVISION
11/01/17

DESCRIPTION:



FY 2019-20
STANDARD PLANS

SUPPLEMENTARY DETAILS FOR
MANHOLES AND INLETS

INDEX
425-001

SHEET
1 of 5

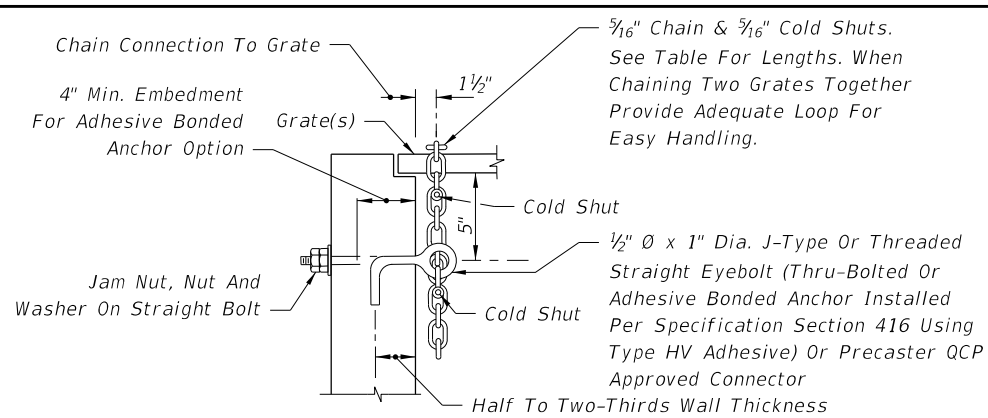

NOTE: When Alternate "G" grate is specified, the chain, bolt, nuts, washer and cold shuts shall be galvanized in accordance with Section 425 of the Standard Specifications.

Cost of eyebolt and chain to be included in the contract unit price for inlets.

EYEBOLT AND CHAIN REQUIREMENTS				
Index Number	Inlet Type	Eye-Bolts	Length Of Chain	Handling & Remarks
425-030	1	1	4'-0"	Slide & Spin
	2	1	4'-0"	Slide & Spin
	3	2	2 @ 4'-0"	Slide & Spin
	4	2	2 @ 4'-0"	Slide & Spin
	5	2	2 @ 4'-0"	Slide & Spin
425-031	N/A	1	3'-8"	Slide Or Slide & Spin
425-032	N/A	1	4'-0"	Slide & Spin
425-040	S	1	4'-0"	Slide & Spin
425-041	V	1	4'-0"	Slide & Spin
425-050	A	1	3'-0"	Slide
425-051	B	1	5'-0"	Slide & Spin
425-052	C	1	2'-6"	Slide & Spin
	D	1	2'-6"	Slide & Spin
	E	2	2 @ 2'-6"	Slide & Spin
	H	2	2 @ 2'-6"	Flip Ctr. Grate and Slide & Spin Single Free Grate 1 or 2 @ 1'-6" Center Grate(s) Chained To One End Grate
425-053	F	1	3'-6"	Flip Or Slide & Spin
	G	1	6'-0"	Slide
425-054	J	1	2'-0"	Lifting Loop
			4'-0"	Slide & Spin

EYEBOLT AND CHAIN FOR LOCKING GRATES TO INLETS

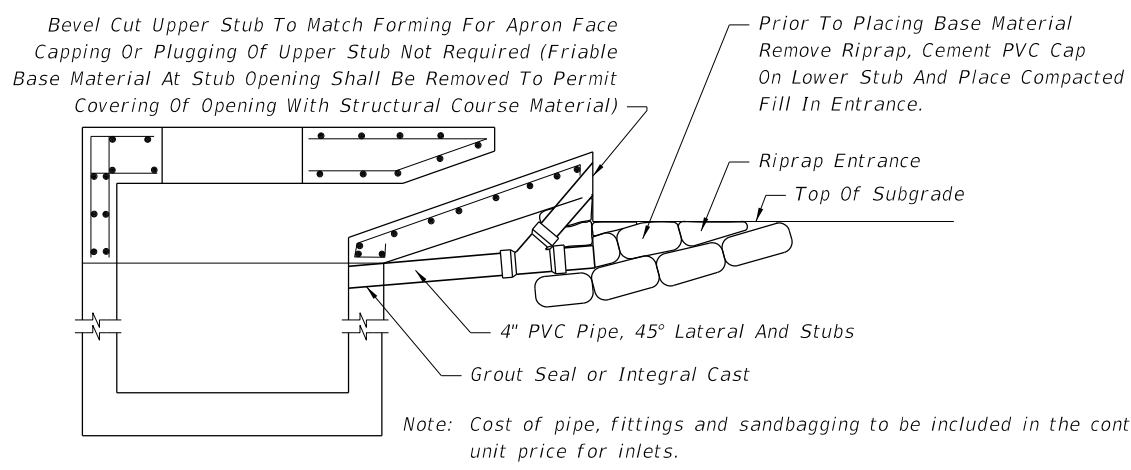

Note: Cost of pipe, fittings and sandbagging to be included in the contract unit price for inlets.

TEMPORARY DRAINS FOR SUBGRADE AND BASE

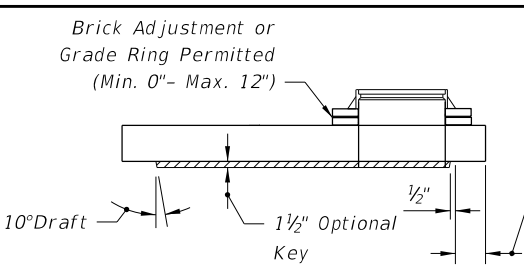

SECTION TYPE 7
Note: See Slab Designs Index 425-010.

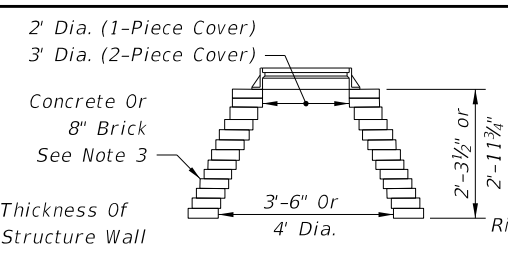

BRICK OR CONCRETE PRECAST CONCENTRIC CONE TYPE 8

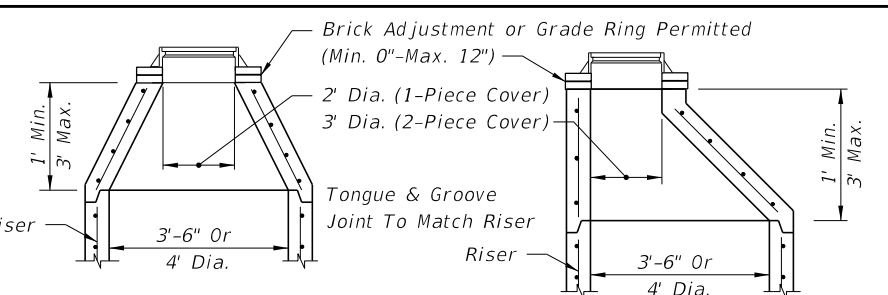

MANHOLE TOPS

NOTES (TOPS)

1. Manhole top Type 7 slabs shall be of Class II concrete. Concrete as specified in ASTM C478 may be used for precast units; see General Note 3.
2. Manhole top Type 7 slabs may be of cast-in-place or precast construction. The optional key is for precast tops and in lieu of dowels. Frame and slab openings are to be omitted when top is used over a junction box.
3. Manhole top Type 8 may be of cast-in-place or precast concrete construction or brick construction. For concrete construction, the concrete and steel reinforcement shall be the same as the supporting wall unit. An eccentric cone may be used.
4. Manhole tops shall be secured to structures by optional construction joints as shown on Sheet 3.
5. Frames can be adjusted a maximum 12" height with brick or precast ASTM C478 grade rings.
6. Substitution of manhole top Type 8 for manhole top Type 7 is allowed provided that minimum dimensions shown above are not reduced.
7. Substitution of Manhole top Type 7 for Type 8 is allowed if the minimum thickness (h) above pipe opening cannot be maintained with manhole top Type 8.

DESIGN NOTES

1. Manhole top Type 8 should be specified in the plans when depths shown above can be maintained.

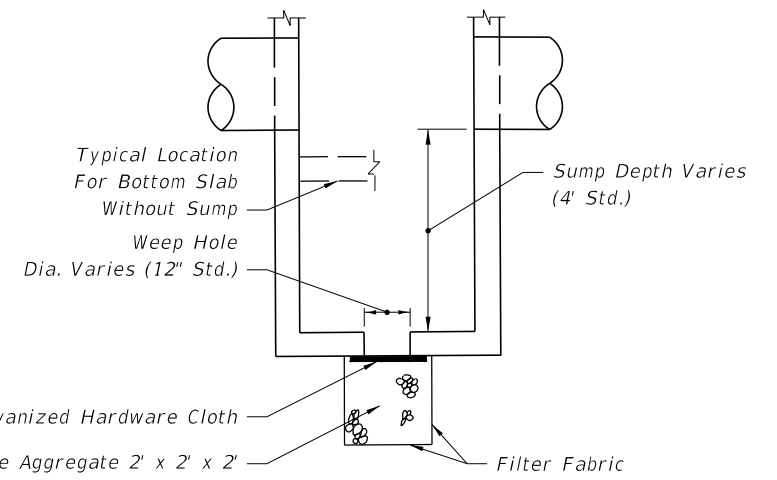

NOTE: Sump bottom appropriate for all manhole and inlet types. Sumps are to be constructed in inlet and manholes connected to French Drains unless excluded in the plans. At other locations, sump is to be constructed only where called for in the plans. Weep holes to be constructed in sump bottom only where called for in the plans. Cost of sump bottom and weep hole to be included in the contract unit price for inlet or manhole.

SUMP BOTTOM

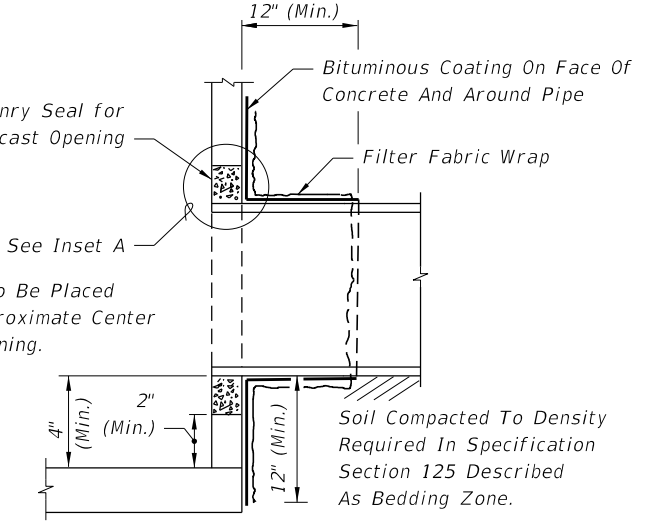
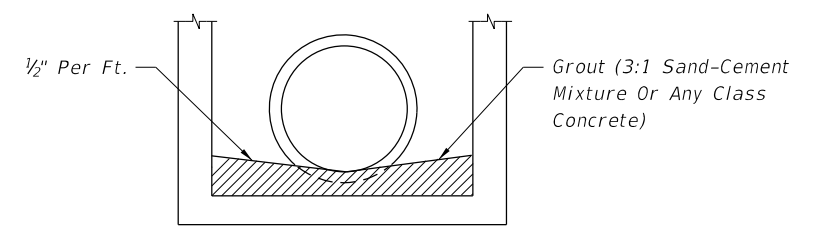

FILTER FABRIC WRAP ON GROUTED PIPE TO STRUCTURE JOINT

FOR ALL STRUCTURES UNLESS EXCLUDED BY SPECIAL DETAIL ALL PIPE TYPES DRAINAGE STRUCTURE INVERT

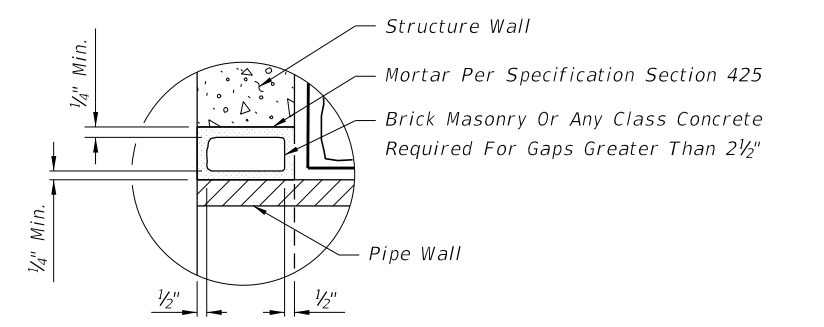

INSET A

10/30/2018 8:42:37 AM

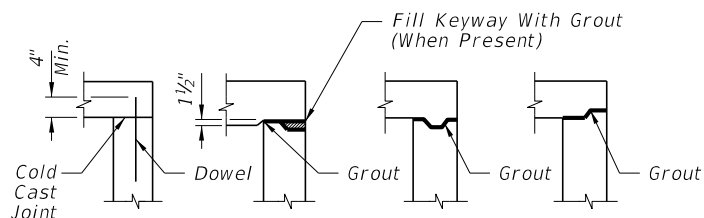

TOP SLABS TO WALLS

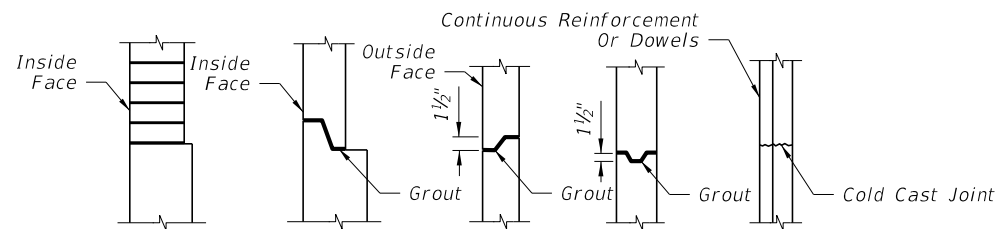

WALL JOINTS

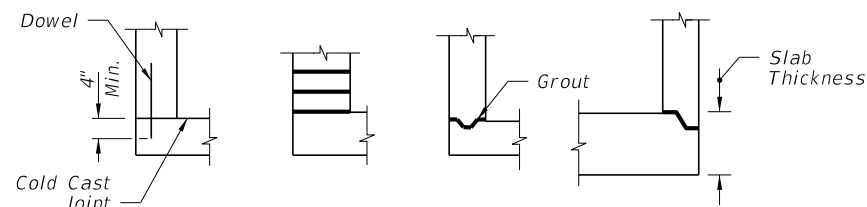

BOTTOM SLABS TO WALLS

1. One or more types of joints may be used in a single structure, except brick wall structure. Brick wall construction is permitted on circular units only.
2. All grouted joints are to have a maximum thickness of 1".
3. Keyways are to be a minimum of 1 1/2" deep.
4. Joint dowels are to be #4 bars, 12" long with a minimum of 6 bars per joint approximately evenly spaced for circular structures or at maximum 12" spacing for rectangular structures. Bars may be either Adhesive Bonded Dowels in accordance with Specification Section 416, or placed approximately 6" into fresh concrete leaving the remainder to extend into the secondary cast. Welded wire reinforcement may be substituted for the dowel bar in accordance with the equivalent steel area table on Sheet 4.
5. Minimum cover on dowel reinforcing bars is 2" to outside face of structure.
6. Joints between wall segments and between wall segments and top or bottom slabs may be sealed either by preformed plastic gasket material using the procedures given in Section 430 of the Specifications or by non-shrink grout, in accordance with Section 934 of the Specifications.
7. Insert products approved by the Engineer may be used in lieu of dowel embedment.

OPTIONAL CONSTRUCTION JOINTS

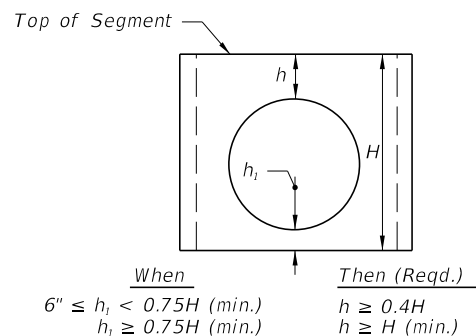

SEPARATE RISER SEGMENTS WITH CONSTRUCTION JOINTS OTHER THAN DOWEL OPTION

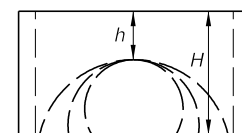

Segments may be inverted. Opening for pipe shall be the pipe OD plus 6" (± 2" tolerance). If h can not be attained, then a top or bottom slab must be attached to the segment as shown below.

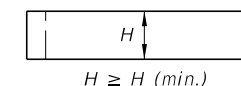

Minimum Value For H	
H (min.)	Box Or Riser Diameter
1'-0"	3'-6" & 4'-0"
1'-6"	5'-0" & 6'-0"
2'-0"	>6'-0"

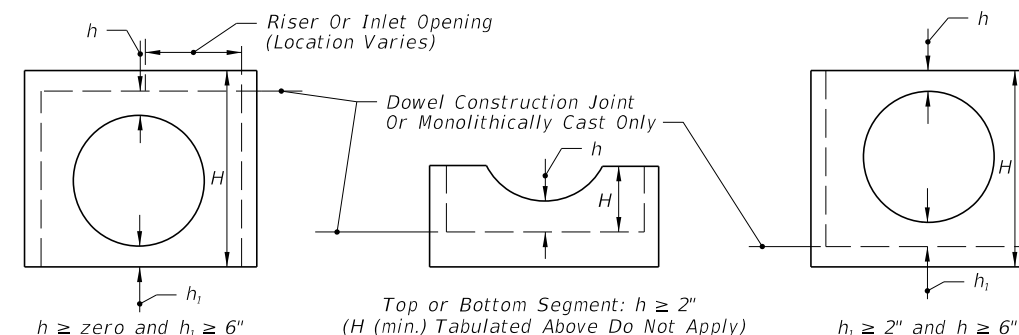

SEGMENTS FOR SLAB TO WALL DOWEL CONSTRUCTION JOINTS OR MONOLITHICALLY CAST SEGMENTS

NOTE: h may be less than 6" when approved by the Engineer, but not for inlet segments at finish grade elevation.

COMPARATIVE SIDE VIEWS

MINIMUM DIMENSIONS FOR BOX AND RISER SEGMENTS

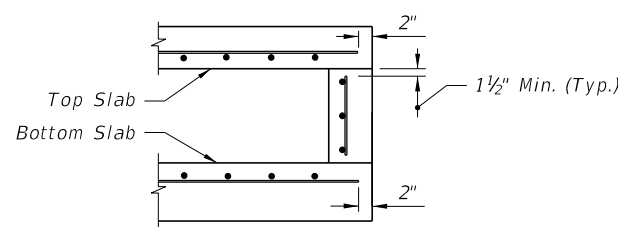

(NOTE: NOT APPLICABLE AROUND MANHOLE AND RISER OPENINGS)

REBAR STRAIGHT END EMBEDMENT FOR TOP AND BOTTOM SLABS

Option 1) Lap Splice: At Quarter Point (30 Bar Diameters Or Vertical Wire Spacing Plus 2" For WWR)
 Option 2) Lap Splice: Standard 90° Hooks At Corners (8" For #4's, 10" For #5's, 12" for #6's)

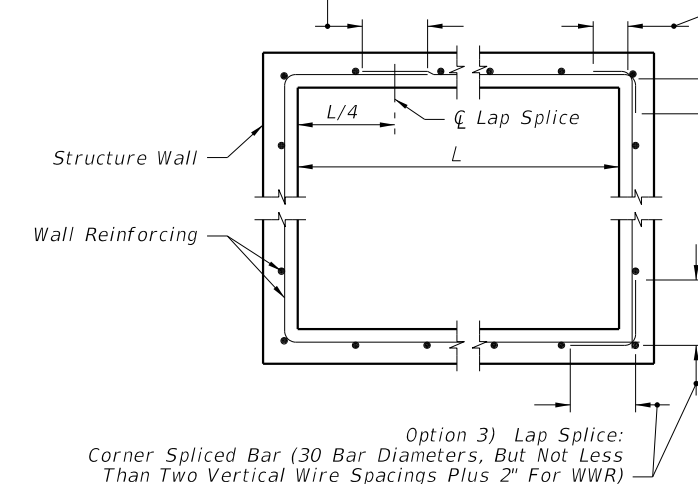

Option 3) Lap Splice: Corner Spliced Bar (30 Bar Diameters, But Not Less Than Two Vertical Wire Spacing Plus 2" For WWR)

WALL REINFORCING SPLICE DETAILS

10/30/2018 8:42:40 AM

EXAMPLE TABLE OF EQUIVALENT STEEL AREA

SCHEDULE	GRADE 60 REINFORCING BAR		EQUIVALENT GRADE 40 REINFORCING BAR		EQUIVALENT 65 KSI SMOOTH WELDED WIRE REINFORCEMENT		EQUIVALENT 70 KSI DEFORMED WELDED WIRE REINFORCEMENT	
	Bar Size & Spacing	Steel Area (in ² /ft)	Bar Size & Spacing	Min. Steel Area (in ² /ft)	Style Designation	Min. Steel Area (in ² /ft)	Style Designation	Min. Steel Area (in ² /ft)
A	#3 @ 6 1/2" Ctrs. #4 @ 12" Ctrs.	0.20	#3 @ 4 1/2" Ctrs. #4 @ 8" Ctrs. #5 @ 12" Ctrs.	0.30	3"x3"-W4.6xW4.6 4"x4"-W6.2xW6.2 6"x6"-W9.2xW9.2	0.1846	3"x3"-D4.3xD4.3 4"x4"-D5.7xD5.7 6"x6"-D8.6xD8.6	0.1714
B	#3 @ 5 1/2" Ctrs. #4 @ 10" Ctrs.	0.24	#3 @ 3 1/2" Ctrs. #4 @ 6 1/2" Ctrs. #5 @ 10" Ctrs.	0.36	3"x3"-W5.5xW5.5 4"x4"-W7.4xW7.4 6"x6"-W11.1xW11.1	0.2215	3"x3"-D5.1xD5.1 4"x4"-D6.9xD6.9 6"x6"-D10.3xD10.3	0.2057
Special 1	#3 @ 5" Ctrs. #4 @ 9" Ctrs.	0.267	#3 @ 3" Ctrs. #4 @ 6" Ctrs. #5 @ 9" Ctrs.	0.40	3"x3"-W6.2xW6.2 4"x4"-W8.2xW8.2 6"x6"-W12.3xW12.3	0.2465	3"x3"-D5.7xD5.7 4"x4"-D7.6xD7.6 6"x6"-D11.4xD11.4	0.2289
C	#3 @ 3 1/2" Ctrs. #4 @ 6 1/2" Ctrs. #5 @ 10" Ctrs.	0.37	#4 @ 4" Ctrs. #5 @ 6 1/2" Ctrs. #6 @ 9 1/2" Ctrs.	0.555	3"x3"-W8.5xW8.5 4"x4"-W11.4xW11.4 6"x6"-W17.1xW17.1	0.3415	3"x3"-D7.9xD7.9 4"x4"-D10.6xD10.6 6"x6"-D15.9xD15.9	0.3171
D	#4 @ 4 1/2" Ctrs. #5 @ 7" Ctrs. #6 @ 10" Ctrs.	0.53	#4 @ 3" Ctrs. #5 @ 4 1/2" Ctrs. #6 @ 6 1/2" Ctrs.	0.795	3"x3"-W12.2xW12.2 4"x4"-W16.3xW16.3 6"x6"-W24.5xW24.5	0.4892	3"x3"-D11.4xD11.4 4"x4"-D15.1xD15.1 6"x6"-D22.7xD22.7	0.4543
E	#4 @ 3" Ctrs. #5 @ 5" Ctrs. #6 @ 7" Ctrs.	0.73	#5 @ 3 1/2" Ctrs. #6 @ 4 1/2" Ctrs. #7 @ 6 1/2" Ctrs.	1.095	3"x3"-W16.8xW16.8 4"x4"-W22.5xW22.5 6"x6"-W33.7xW33.7	0.6738	3"x3"-D15.6xD15.6 4"x4"-D20.9xD20.9 6"x6"-D31.3xD31.3	0.6257
F	#5 @ 3 1/2" Ctrs. #6 @ 5" Ctrs. #7 @ 7" Ctrs.	1.06	#6 @ 3" Ctrs. #7 @ 4 1/2" Ctrs. #8 @ 6" Ctrs.	1.59	3"x3"-W24.5xW24.5 4"x4"-W32.6xW32.6 6"x6"-W48.9xW48.9	0.9785	3"x3"-D22.7xD22.7 4"x4"-D30.3xD30.3 6"x6"-D45.4xD45.4	0.9086
Special 2	#5 @ 3" Ctrs. #6 @ 4" Ctrs. #7 @ 5 1/2" Ctrs.	1.24	#7 @ 4" Ctrs. #8 @ 5" Ctrs.	1.86	3"x3"-W28.6xW28.6 4"x4"-W38.2xW38.2 6"x6"-W57.2xW57.2	1.1446	3"x3"-D26.6xD26.6 4"x4"-D35.4xD35.4 6"x6"-D53.1xD53.1	1.0629
G	#6 @ 3 1/2" Ctrs. #7 @ 5" Ctrs.	1.46	#7 @ 3" Ctrs. #8 @ 4" Ctrs.	2.19	3"x3"-W33.7xW33.7 4"x4"-W44.9xW44.9	1.3477	3"x3"-D31.3xD31.3 4"x4"-D41.7xD41.7	1.2514

NOTES FOR PRECAST OPTIONS AND EQUIVALENT REINFORCEMENT SUBSTITUTION

- Details for optional precast inlet construction up to depths of 15' are shown on the inlet indexes.
- When precast units are used in conjunction with Alt. "B" Structure Bottoms, Index 425-010, the interior dimensions of an Alt. "B" Bottom can be adjusted to reflect these inlet interior dimensions.
- Concrete which meets the requirements of ASTM C478 or Class IV must be used for precast structures constructed with 6" wall or slab thickness.
- Reinforcement can be either deformed bar reinforcement or welded wire reinforcement. Bar reinforcement other than 60 ksi may be used, however only two grades are recognized; Grade 40 and Grade 60. Smooth welded wire reinforcement, will be recognized as having a design strength of 65 ksi and deformed welded wire reinforcement will be recognized as having a design strength of 70 ksi. The area of reinforcement required may be adjusted in accordance with the Equivalent Steel Area Table provided. For bars and spacings not given, the steel area required can be determined by the following equations:

$$\text{Grade 40 Steel Area} = A_{s40} = \frac{60}{40} \times A_{s60}$$

$$\text{Smooth Welded Wire Reinforcement Steel Area} = A_{s65} = \frac{60}{65} \times A_{s60}$$

$$\text{Deformed Welded Wire Reinforcement Steel Area} = A_{s70} = \frac{60}{70} \times A_{s60}$$

When a reduced area of reinforcement is provided, any maximum bar spacing shown must also be reduced as determined by the following equations, unless otherwise shown:

$$\begin{aligned} \text{Max. Grade 40 Bar Spacing} &= \text{Grade 60 Bar Spacing} \\ \text{Max. Smooth Welded Wire Spacing} &= \text{Grade 60 Bar Spacing} \times 0.86 \\ \text{Max. Deformed Welded Wire Spacing} &= \text{Grade 60 Bar Spacing} \times 0.74 \end{aligned}$$

When an increased area of reinforcing is provided, then the maximum bar spacing may be increased by the squared ratio of increased steel area, but not to exceed 12":

$$\text{Max. Bar Spacing Provided} \leq \text{Max. Bar Spacing Required} \times \left(\frac{\text{Steel Area Provided}}{\text{Min. Steel Area Required}} \right)^2$$

In no case will reinforcement with wires smaller than W3.1 or D4.0, or spacings greater than 8" be permitted. Bar reinforcement shall show the minimum yield designation grade mark or either the number 60 or one (1) grade mark line to be acceptable at the higher value. Maximum bar spacing shall not be greater than two (2) times the slab thickness with a maximum spacing of 12" or three (3) times the wall thickness, with a maximum spacing of 18" for vertical bars and 12" for horizontal bars. Wires smaller than W3.1 or D4.0 are permitted in the walls of ASTM C 478 round structure bottoms and round risers.

- Fiber-reinforced concrete may be substituted for conventional steel reinforcement in accordance with the Structures Design Guidelines. Shop drawings corresponding to an approved fiber-reinforced concrete mix design must be submitted for approval to the State Drainage Engineer.

GENERAL NOTES

- For square or rectangular precast drainage structures, using either deformed or smooth WWR meeting the requirements of Specification Section 931, WWR shall be continuous around the box and lapped in accordance with Option 1 or 3 as shown in the Wall Reinforcing Splice Details.
- Horizontal steel in the walls of rectangular structures shall be lap spliced in accordance with Option 1, 2 or 3 as shown in the Wall Reinforcing Splice Details.
- Welding of splices and laps is permitted. The requirements and restrictions placed on welding in AASHTO M259 shall apply.
- Rebar straight end embedment of peripheral reinforcement may be used in lieu of ACI standard hooks for top and bottom slabs except when hooks are specifically called for in the plans or standard drawings.
- Concrete as specified in ASTM C478, (4000 psi) may be used in lieu of Class II concrete in precast items manufactured in plants which meet the requirements in accordance with Specification Section 449.
- Precast opening for pipe shall be the pipe OD plus 6" (± 2" tolerance). Mortar used to seal the pipe into the opening will be of such a mix that shrinkage will not cause leakage into or out of the structure. Dry-pack mortar may be used in lieu of brick and mortar construction to seal openings less than 2 1/2" wide.
- For pay item purposes, the height used to determine if a drainage structure is greater than 10 feet shall be computed using:
 - the elevation of the top of the manhole lid,
 - the grate elevation or the theoretical gutter grade elevation of an inlet, or
 - the outside top elevation of a junction box less the flow line elevation of the lowest pipe or to top of sump floor.

10/30/2018 8:42:44 AM

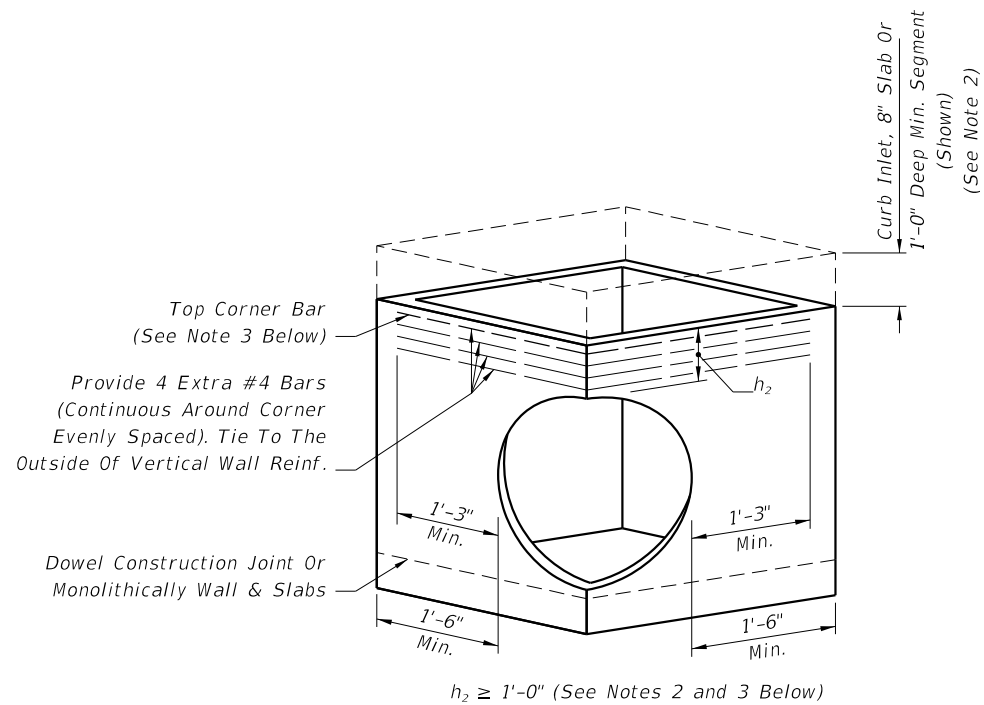

$h_2 \geq 1'-0''$ (See Notes 2 and 3 Below)

DESIGNER NOTE: Use only when round structures are not practical, engineer of record approval required.

PICTORIAL VIEW

- NOTE: 1. Submit Shop Drawings of corner openings for approval by the Engineer of Record.
2. h_2 may be less than 1'-0" when a minimum 1'-0" deep segment, 8" slab or curb inlet is provided above the corner opening.
3. For inlet segments at finish grade elevation substitute a #8 Bar for the top corner bar when $1'-0'' \leq h_2 < 2'-0''$.

RECTANGULAR SEGMENT WITH PIPE OPENING AT CORNER

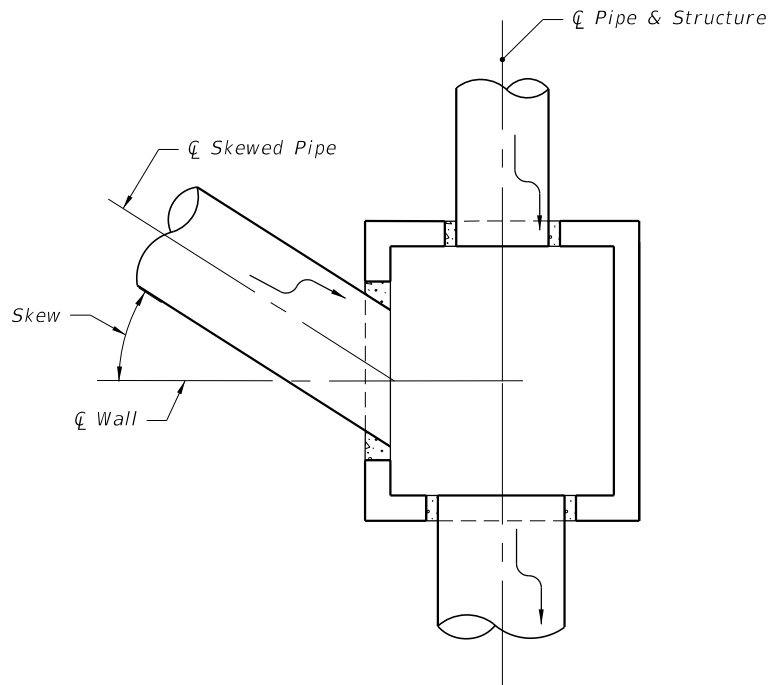

**PLAN VIEW FOR SKEWS $\leq 45^\circ$
(Not Centered)**

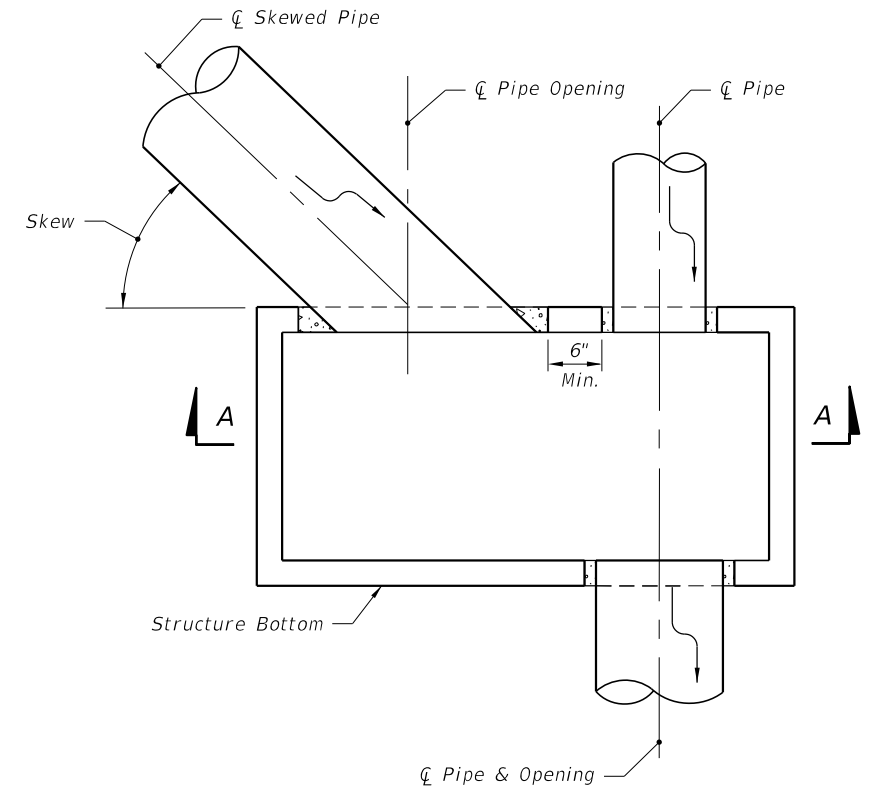

**PLAN VIEW FOR SKEWS $> 45^\circ$
(Not Centered)**

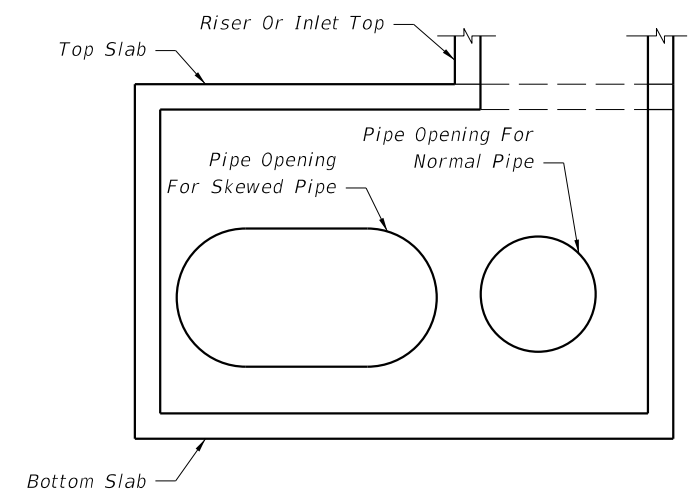

SECTION AA
(Pipes Not Shown For Clarity)

DETAILS FOR SKEWED PIPES IN RECTANGULAR STRUCTURES

10/30/2018 8:42:48 AM

LAST REVISION 11/01/17	REVISION	DESCRIPTION:	 FY 2019-20 STANDARD PLANS	SUPPLEMENTARY DETAILS FOR MANHOLES AND INLETS	INDEX 425-001	SHEET 5 of 5
---------------------------	----------	--------------	-------------------------------------------------------------------------------------------------------------------------------	----------------------------------------------------------	-------------------------	------------------------

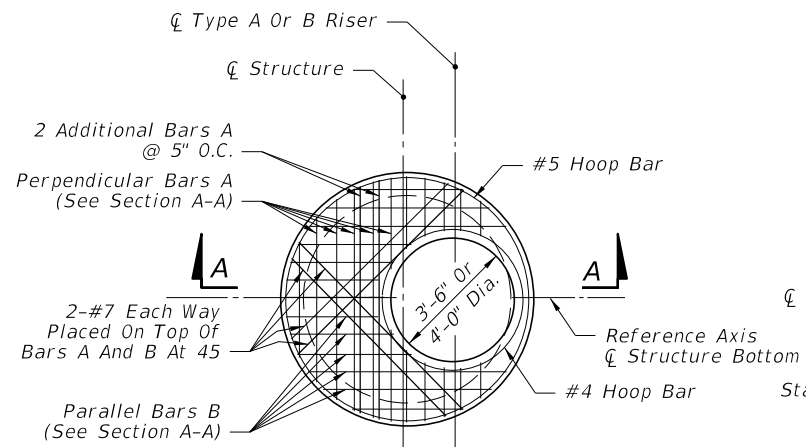

NOTE:
Not Applicable For Type A, B, C, D & E Ditch Bottom Inlets Or Type S & V Gutter Inlets.
See Indexes 425-040, 425-050, 425-051, and 425-052.

**TOP SLAB REINFORCING STEEL DIAGRAM
(ALTERNATE A)**

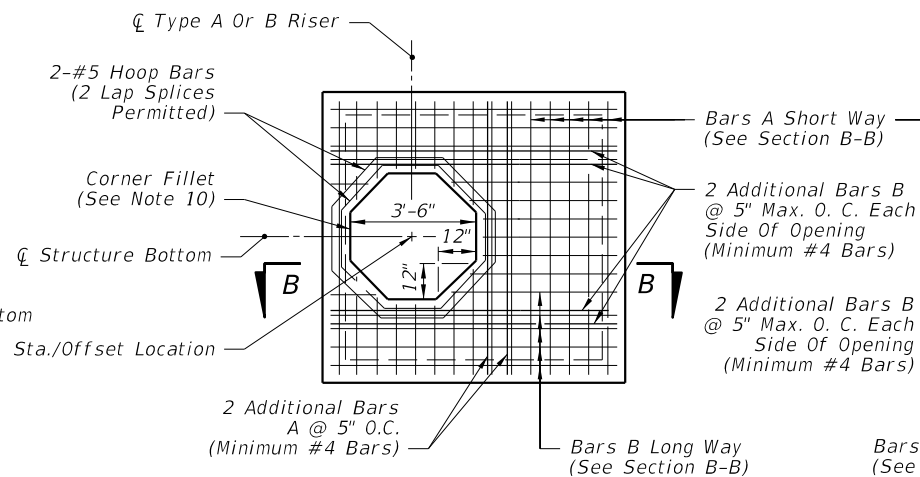

**SQUARE OPENING WITH CORNER FILLETS
TOP SLAB REINFORCING STEEL DIAGRAM
(ALTERNATE B)**

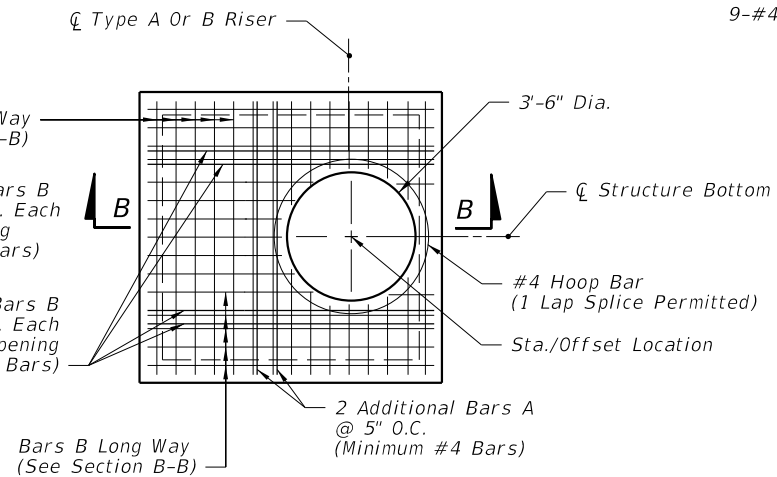

**ROUND RISER OPENING
TOP SLAB REINFORCING STEEL DIAGRAM**

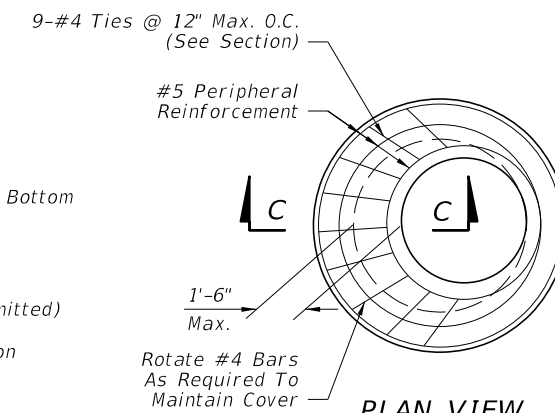

PLAN VIEW

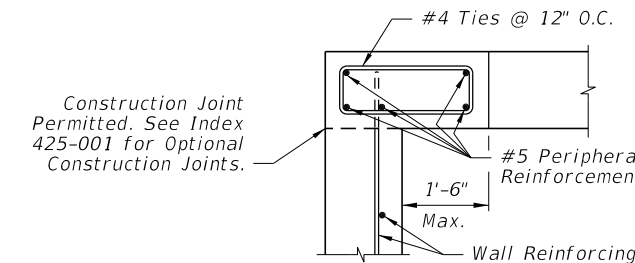

**SECTION C-C
SPECIAL TOP SLAB***

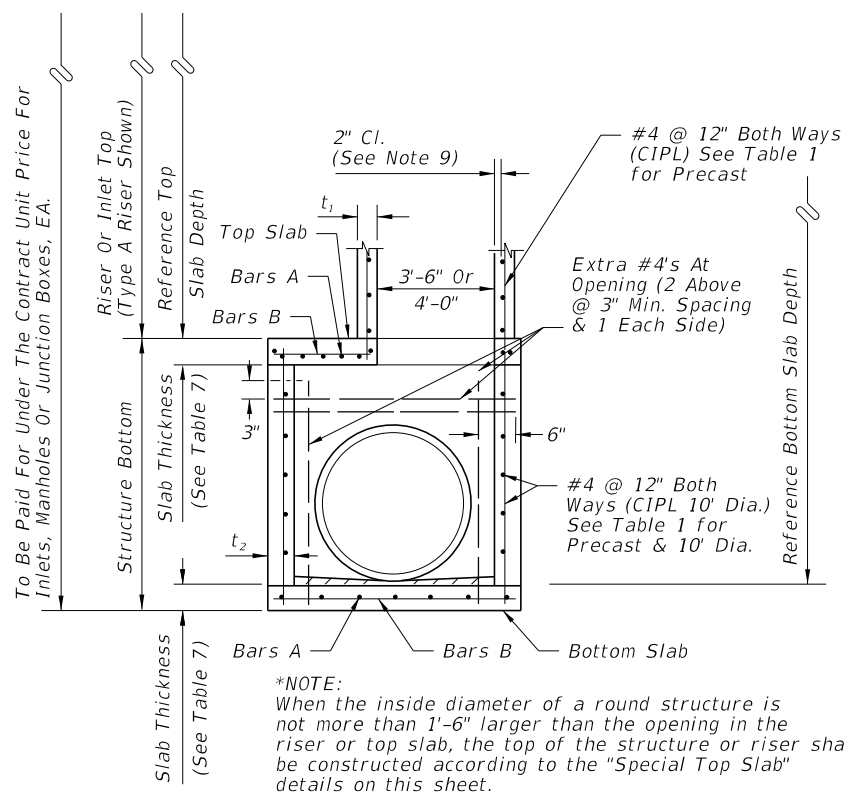

**SECTION A-A
(ALTERNATE A)**

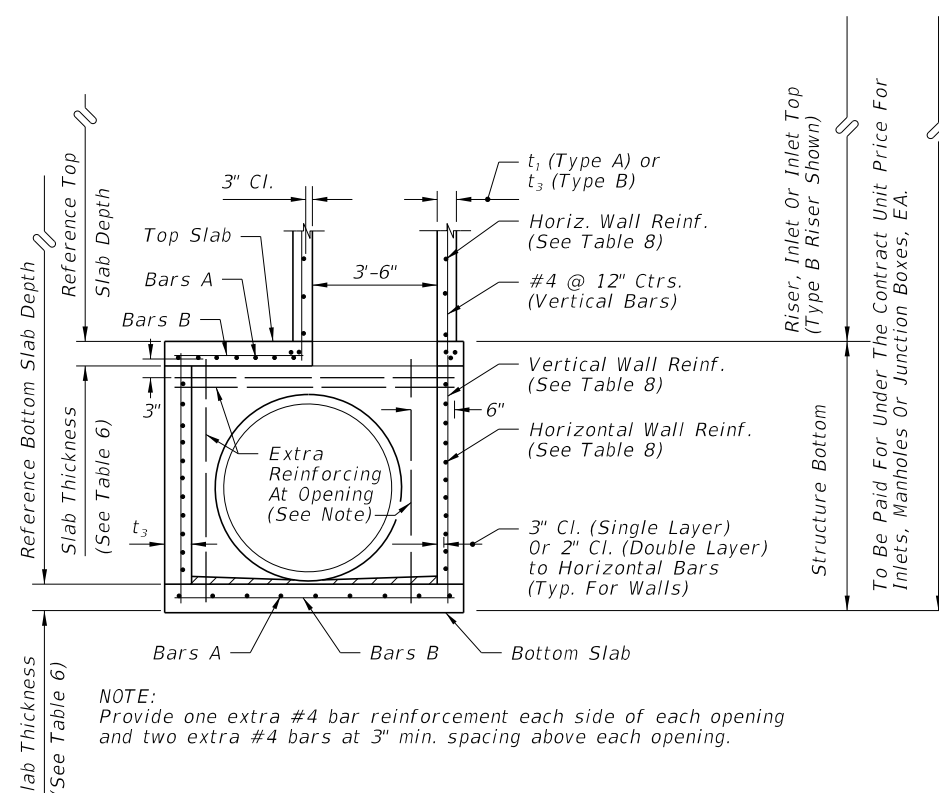

**SECTION B-B
(ALTERNATE B)**

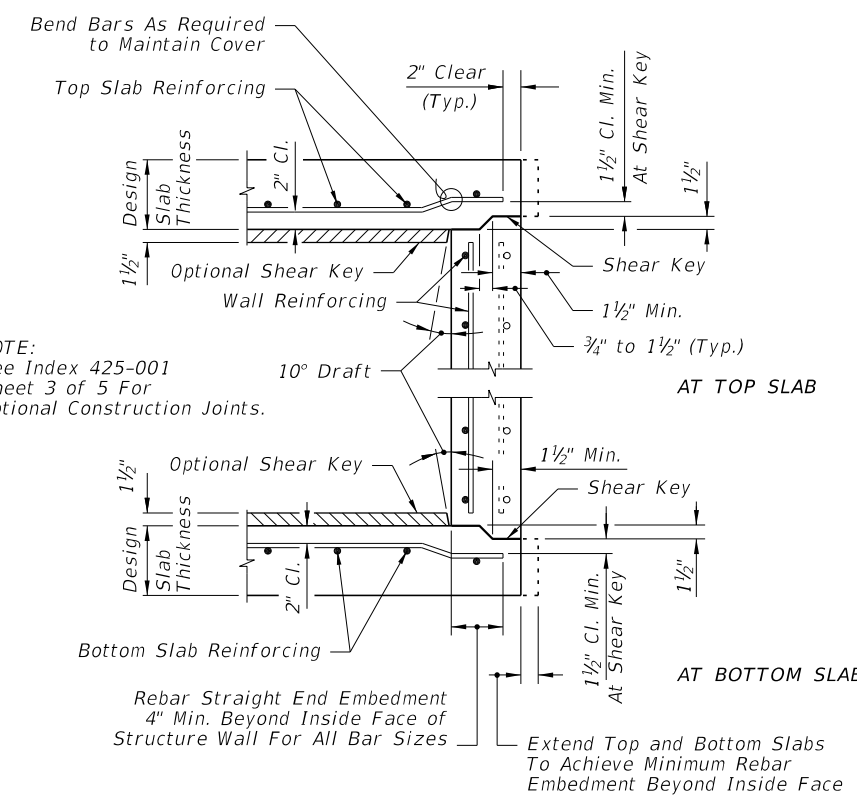

**TYPICAL SLAB TO WALL DETAILS
FOR PRECAST STRUCTURES**

10/30/2018 8:42:54 AM

LAST REVISION 11/01/17	DESCRIPTION:		FY 2019-20 STANDARD PLANS	STRUCTURE BOTTOMS TYPE J AND P	INDEX 425-010	SHEET 1 of 5
REVISION						

GENERAL NOTES

ROUND STRUCTURE BOTTOMS (ALTERNATE A) & ROUND RISERS- TABLE 1									
Wall Thickness (t ₁ & t ₂) and Vertical & Horizontal Areas of Reinforcement (A _s)									
Type	Structure/Riser Diameter (ft)	Cast-In-Place Items Class II Concrete			Precast Items				
		t ₁ Riser (in.)	t ₂ Bottom (in.)	A _s (in. ² /ft.)	Class II Concrete			ASTM C478	
					t ₁ Riser (in.)	t ₂ Bottom (in.)	A _s (in. ² /ft.)	t ₁ or t ₂ (in.)	A ₂ *** (in. ² /ft.)
P	3'-6"	6	8	0.20	6	8	0.20	4**	0.105
P	4'-0"	6	8	0.20	6	8	0.20	5**	0.120
J	5'-0"	-	8	0.20	-	8	0.20	6**	0.150
J	6'-0"	-	8	0.20	-	8	0.20	6	0.180
J	7'-0"	-	8	0.20	-	8	0.20	7	0.210
J	8'-0"	-	8	0.20	-	8	0.20	8	0.240
J	10'-0"	-	10	0.40##	-	10	0.40##	10	0.300
J	12'-0"	-	10	0.40##	-	12	0.40##	12	0.360

TABLE 1 NOTES:

##Provide 0.20 eq. in.²/ft. at each face, 12" max. bar spacing.

**Modified minimum wall thickness.

***Min. total circumferential reinforcement for continuous steel hoops:

A₂ = 0.40 sq. in. for riser section height equal or less than 2'-0" (2 hoop min.)

A₂ = 0.60 sq. in. for riser section height more than 2'-0" up to 4'-0" (3 hoop min.)

Areas of reinforcing for precast items are based on Grade 60 reinforcing;

No reduction in the area of reinforcement is allowed for welded wire fabric in Table 1;

Area of vertical reinforcing may be reduced in accordance with ASTM C478.

SQUARE & RECTANGULAR STRUCTURES (ALTERNATE B) - TABLE 2				
Type	Wall Length (ft)	Max. Depth (ft)	Wall Thickness (t ₃)	
			CIP (in.)	Precast (in.)
P	≤ 3'-6"	40	6 Riser 8 Bottom	6
J	4'-0"	40	8	6
J	5'-0"	22	-	6
J	6'-0"	15	-	6
J	5'-0" to 9'-0"	40	8	8
J	10'-0"	26	8	8
J	10'-0" to 12'-0"	40	10	9
J	16'-0"	35	-	9
J	16'-0"	40	10	10
J	20'-0"	25	-	9
J	20'-0"	30	10	10

TABLE 2 NOTES:

See Table 8 for Reinforcing Schedule.

- Standard structure bottoms 4'-0" diameter and smaller (Alt. A) and 3'-6" square (Alt. B) are designated Type P. Larger standard structure bottoms are designated Type J. Risers are permitted for all structures. Round risers are designated Type A, square risers are designated Type B.
- Walls of circular structures (Alt. A) constructed in place may be of brick or reinforced concrete. Precast and rectangular structures (Alt. B) shall be constructed of reinforced concrete only.
- Wall thickness and reinforcement are for either reinforced cast-in-place or precast concrete units except that precast circular units may be furnished with walls in accordance with ASTM C478 (see modified wall thicknesses in Table 1).
- Top and bottom slab thickness and reinforcement are for precast and cast-in-place construction. All concrete shall be of Class II concrete, except use Class IV concrete when shown in the Plans, for special applications of structures located in extremely aggressive environments. Concrete as specified in ASTM C478 (4000 psi) may be used in lieu of Class II concrete for precast items manufactured in accordance with Specifications Section 449.
- All reinforcement shown is Grade 60 steel, deformed bar. Equivalent area Grade 40 steel or equivalent area smooth or deformed welded wire reinforcement in accordance with Specification Section 931 may be substituted according to Index 425-001, unless otherwise noted.
- Alt. A or Alt. B structure bottoms may be used in conjunction with curb inlet tops Types 1, 2, 3, 4, 5, 6, 9, and 10, and any manhole or junction box unless otherwise shown in the plans or other standard drawings. Alt. B structure bottoms may be used in conjunction with curb inlet Types 7 & 8, or any ditch bottom inlet unless otherwise shown in the plans or other standard drawings.
- Rectangular structures may be rotated as directed by the Engineer in order to facilitate connections between the structure walls and storm sewer pipes.
- Except when ACI hooks are specifically required, reinforcement in top and bottom slab shall be straight embedment.
- All reinforcement must have 2" minimum cover except for 3'-6" diameter precast circular units manufactured under ASTM C478, keyed construction otherwise shown. Additional bars used to restrain hole formers for precast structures with grouted pipe connections may be left flush with the hole surface. Cut or bend reinforcement at pipe openings to maintain cover. Exposed ends of reinforcing at precast pipe openings and grouted joints must be removed to 1" below the concrete surface and sealed with a Type F epoxy in accordance with Specification Section 926. Horizontal steel in rectangular structures shall be lapped a minimum of 30 bar diameters or by standard hooks at corners.
- The corner fillets shown are necessary for rectangular structures used with circular risers and inlet throats and when used on skew with rectangular risers, inlets and inlet throats. Fillets will be required in the top slab of the Alt. A structure bottoms when used with the Alt. B risers. Each fillet shall be reinforced with two #5 bars.
- Inlet walls, throats, risers or manhole tops shall be secured to structures as shown on Index 425-001 Optional Construction Joints.
- Structures with depths over 14' below the mean high water table are to be checked for flotation by the designer of the drainage project.
- Units larger than specified standards may be substituted at the contractor's option when these units will not cause or increase the severity of utility conflicts. Such larger units shall be furnished at no additional cost to the Department. Larger Alt. A units cannot replace Alt. B units without approval of the Engineer. This note applies to this Index only.
- For manhole and junction box tops, for frames and covers, and, for supplementary details and notes see Index 425-001.
- Type J structure bottoms must have a minimum 6'-0" wall height when possible, for maintenance access.

10/30/2018 8:42:58 AM

TABLE 3-MINIMUM STRUCTURE SIZES FOR SINGLE PIPE CONNECTION PER SIDE

PIPE SIZE	RECTANGULAR		ROUND	
	Side Dimension (L)		Diameter (D)	
	Single Pipe Per Side	Note Number	Single Pipe or $\theta=180^\circ$	2 to 4 Pipes $\theta=90^\circ$
18"	3'-6"		3'-6"	4'-0"
24"	3'-6"		3'-6"	5'-0"
30"	3'-6"/4'-0"	2	4'-0"	6'-0"
36"	4'-0"/5'-0"	3	5'-0"	7'-0"
42"	5'-0"		6'-0"	7'-0"
48"	6'-0"		6'-0"	8'-0"
54"	6'-0"		7'-0"	10'-0"
60"	7'-0"		7'-0"	10'-0"
66"	7'-0"/8'-0"	4	8'-0"	12'-0"
72"	8'-0"		8'-0"	12'-0"
78"	9'-0"		10'-0"	12'-0"
84"	9'-0"		12'-0"	N/A

TABLE 3 NOTES:

- For Round Structures sizes with variable angles between pipes and variable pipe sizes, refer to the FDOT Storm Drain Handbook.
- For 3'-6" Precast Square Structure Bottoms, 30" Pipes with similar invert elevations are not permitted in adjacent walls. Use 4'-0" Side Dimensions when 30" pipe openings are required on adjacent walls and the difference in flow lines is less than 3'-0".
- For 4'-0" Precast Square Structure Bottoms, 36" Pipes with similar invert elevations are not permitted in adjacent walls. Use 5'-0" Side Dimensions when 36" pipe openings are required on adjacent walls and the difference in flow lines is less than 3'-0".
- For 7'-0" Precast Square Structure Bottoms, 66" Pipes with similar invert elevations are not permitted in adjacent walls. Use 8'-0" Side Dimensions when 66" pipe openings are required on adjacent walls and the difference in flow lines is less than 4'-0".

TABLE 4-MINIMUM SIZES FOR MULTIPLE PARALLEL PIPE CONNECTIONS FOR RECTANGULAR STRUCTURE BOTTOMS

PIPE SIZE	PIPE SPACING (S)	MINIMUM WALL LENGTH (L) FOR NUMBER OF PARALLEL PIPES		
		2	3	4
18"	2'-10"	6'-0"	8'-6"	11'-0"
24"	3'-5"	6'-6"	10'-0"	13'-6"
30"	4'-3"	8'-0"	12'-6"	16'-6"
36"	5'-1"	9'-6"	14'-6"	19'-6"
42"	6'-0"	11'-0"	17'-0"	-
48"	6'-9"	12'-6"	19'-0"	-
54"	7'-8"	14'-0"	-	-
60"	8'-6"	15'-0"	-	-
66"	9'-0"	16'-6"	-	-
72"	10'-0"	18'-0"	-	-
78"	10'-9"	19'-0"	-	-
84"	11'-8"	20'-6"	-	-

TABLE 4 NOTES:

- Minimum wall lengths based on precast structures, using concrete pipe with maximum skew angles per Table 5.
- Wall lengths exceeding 20'-0" require special designs.

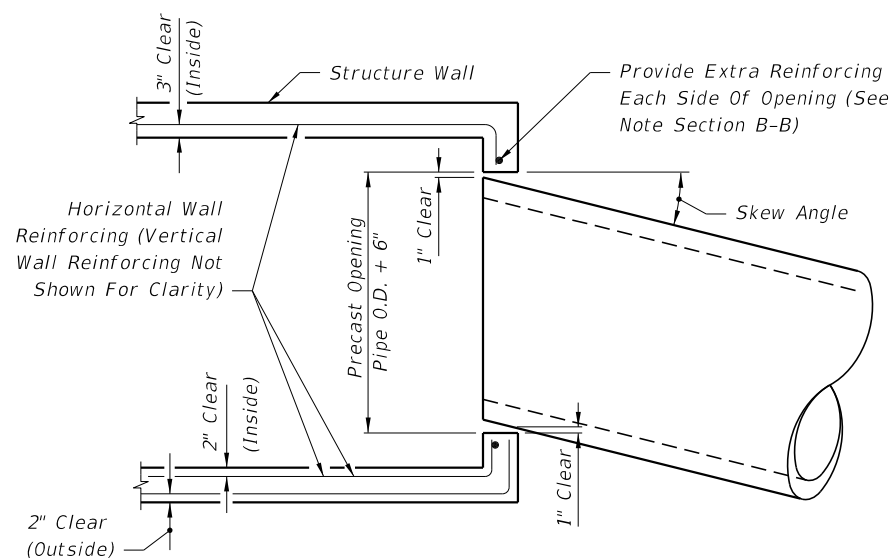

TABLE 5 - MAXIMUM PIPE SKEW FOR PRECAST ROUND OPENINGS

WALL THICKNESS	PIPE SIZE												
	18"	24"	30"	36"	42"	48"	54"	60"	66"	72"	78"	84"	
MAXIMUM SKEW ANGLE	8"	19°	17°	16°	16°	15°	14°	14°	13°	13°	13°	12°	12°
	6"	21°	20°	18°	17°	17°	16°	15°	15°	14°	14°	13°	13°

TABLE 5 NOTES:

These values are based on 2" clearance for precast structures. Larger skews are possible for Cast-In-Place Structures or elliptical pipe openings when approved by the Engineer.

MAXIMUM PIPE SKEW FOR PRECAST ROUND OPENINGS PLAN VIEW

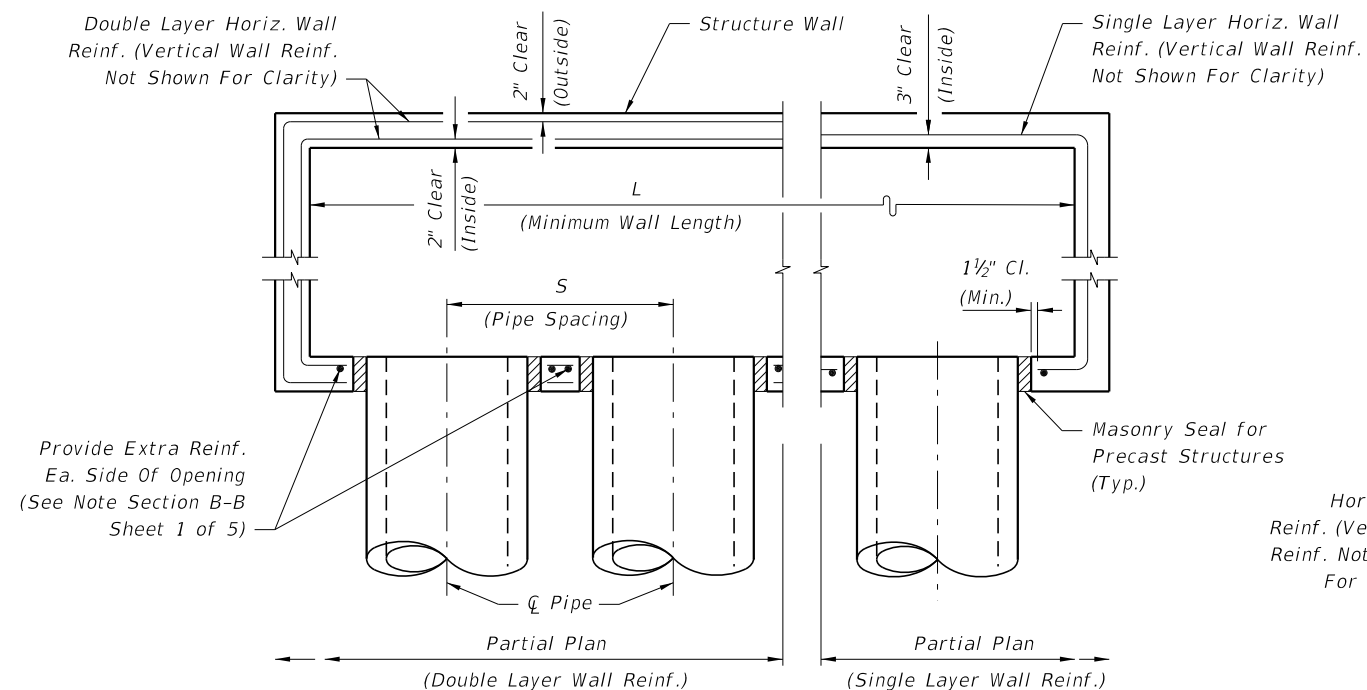

MULTIPLE PARALLEL PIPE CONNECTIONS DETAIL PLAN VIEW

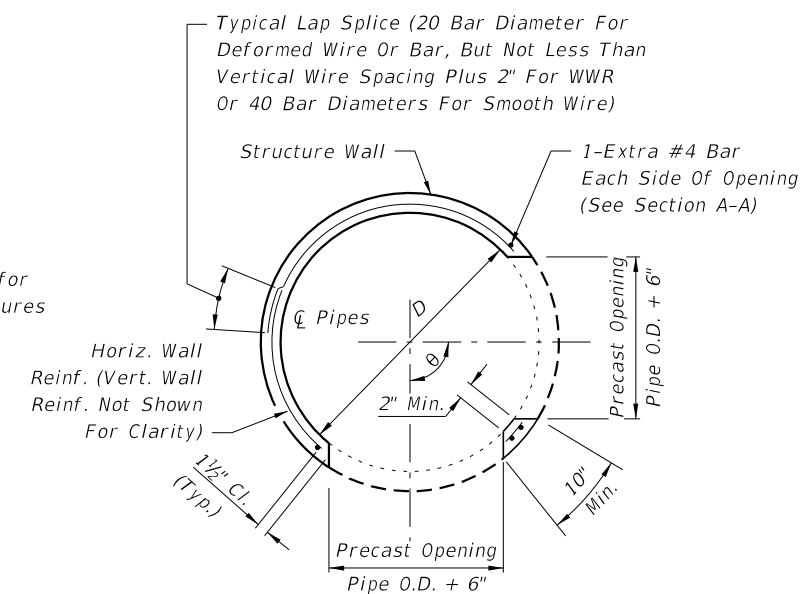

PRECAST ROUND STRUCTURES WITH MULTIPLE PIPE CONNECTIONS

STRUCTURE SIZES FOR PIPE CONNECTIONS

10/30/2018 8:43:01 AM

LAST REVISION 11/01/17	DESCRIPTION:
---------------------------	--------------



FY 2019-20
STANDARD PLANS

STRUCTURE BOTTOMS TYPE J AND P

INDEX
425-010

SHEET
3 of 5

SLAB DESIGNS - SQUARE AND RECTANGULAR STRUCTURES (TABLE 6)
 (ALL SLABS 8" THICK EXCEPT AS NOTED - REINFORCING PARALLEL TO SHORT WAY AND LONG WAY)

SLAB DESIGNS - ROUND STRUCTURES (TABLE 7)

SHORT-WAY		LONG-WAY	
SLAB DEPTH	SCHEDULE (Bars A)	SLAB DEPTH	SCHEDULE (Bars B)
SIZE: 3'-6" x UNLIMITED			
≥0.5' < 8'	B10	≥0.5' < 24'	B10
8' < 13'	B5.5	24'-40'	B5.5
13' < 31'	C6.5		
31'-40'	D7		
SIZE: 4' x UNLIMITED			
≥0.5' < 7'	B5.5	≥0.5' < 15'	B10
7' < 19'	C6.5	15' < 29'	B5.5
19' < 31'	D7	29'-40'	C6.5
31'-40'	E5		
SIZE: 5' x 5'			
≥0.5' < 3'	C6.5	≥0.5' < 3'	C6.5
3' < 7'	B5.5	3' < 13'	C6.5
7' < 22'	C6.5	13' < 22'	D7
22' < 29'	D7	22' < 29'	D4.5
29'-40'	E5	29'-40'	E5
SIZE: 5' x 6'			
≥0.5' < 12'	C6.5	≥0.5' < 3'	C6.5
12' < 26'	D7	3' < 9'	B5.5
26'-40'	E5	9' < 23'	C3.5
		23' < 35'	D4.5
		35'-40'	E5
SIZE: 5' x 7'			
≥0.5' < 10'	C6.5	≥0.5' < 10'	B5.5
10' < 20'	D7	10' < 31'	C3.5
20' < 34'	E5	31'-40'	D4.5
34'-40'	F5		
SIZE: 5' x 8'			
≥0.5' < 7'	C6.5	≥0.5' < 8'	B10
7' < 13'	D7	8' < 17'	B5.5
13' < 24'	E5	17' < 25'	C6.5
24'-40'	F5	25'-40'	C3.5
SIZE: 5' x 9'			
≥0.5' < 8'	C6.5	≥0.5' < 14'	B10
8' < 14'	D7	14' < 24'	B5.5
14' < 25'	E5	24' < 34'	C6.5
25'-40'	F5	34'-40'	C3.5
SIZE: 5' x UNLIMITED			
≥0.5' < 8'	C6.5	≥0.5' < 14'	B10
8' < 14'	D7	14' < 24'	B5.5
14' < 25'	E5	24' < 34'	C6.5
25'-40'	F5	34'-40'	C3.5

SHORT-WAY		LONG-WAY	
SLAB DEPTH	SCHEDULE (Bars A)	SLAB DEPTH	SCHEDULE (Bars B)
SIZE: 6' x 6'			
≥0.5' < 13'	C6.5	≥0.5' < 10'	C3.5
13' < 23'	D7	10' < 18'	D4.5
23'-40'	E5	18' < 27'	E5
		27' < 33'	E3
		33'-40'	F5
SIZE: 6' x 7'			
≥0.5' < 8'	C6.5	≥0.5' < 8'	C6.5
8' < 16'	D7	8' < 12'	C3.5
16' < 28'	E5	12' < 21'	D4.5
28'-40'	F5	21' < 28'	E5
		28' < 35'	E3
		35'-40'	F5
SIZE: 6' x 8'			
≥0.5' < 6'	C6.5	≥0.5' < 6'	B5.5
6' < 13'	D7	6' < 11'	C6.5
13' < 22'	E5	11' < 17'	C3.5
22' < 35'	F5	17' < 22'	D4.5
35'-40'	G5	22' < 32'	E5
		32'-40'	E3
SIZE: 6' x 9'			
≥0.5' < 8'	D7	≥0.5' < 8'	B5.5
8' < 14'	E5	8' < 14'	C6.5
14' < 24'	F5	14' < 21'	C3.5
24'-34'	G5	21' < 25'	D4.5
		25'-34'	E5
SIZE: 6' x UNLIMITED			
≥0.5' < 8'	D7	≥0.5' < 8'	B5.5
8' < 14'	E5	8' < 14'	C6.5
14' < 24'	F5	14' < 21'	C3.5
24'-34'	G5	21' < 25'	D4.5
		25'-34'	E5
SIZE: 7' x 7'			
≥0.5' < 8'	C6.5	≥0.5' < 4'	C6.5
8' < 15'	D7	4' < 7'	C3.5
15' < 26'	E5	7' < 11'	D4.5
26'-40'	F5	11' < 22'	E3
		22' < 32'	F3.5
		32'-40'	G3.5
SIZE: 7' x 8'			
≥0.5' < 5'	C6.5	≥0.5' < 5'	C6.5
5' < 11'	D7	5' < 8'	C3.5
11' < 19'	E5	8' < 13'	D4.5
19' < 30'	F5	13' < 22'	E3
30'-40'	G5	22' < 30'	F3.5
		30'-40'	G3.5
SIZE: 7' x 9'			
≥0.5' < 9'	D7	≥0.5' < 7'	C6.5
9' < 15'	E5	7' < 10'	C3.5
15' < 25'	F5	10' < 14'	D4.5
25' - 34'	G5	14' < 21'	E5
		21' < 29'	F5
		29'-34'	F3.5

SHORT-WAY		LONG-WAY	
SLAB DEPTH	SCHEDULE (Bars A)	SLAB DEPTH	SCHEDULE (Bars B)
SIZE: 8' x 8'			
≥0.5' < 10'	D7	≥0.5' < 9'	D4.5
10' < 19'	E5	9' < 13'	E5
19'-30'	F5	13' < 18'	F5
		18' < 23'	F3.5
		23'-30'	G3.5
SIZE: 8' x 9'			
≥0.5' < 8'	D7	≥0.5' < 7'	D7
8' < 14'	E5	7' < 9'	D4.5
14' < 23'	F5	9' < 15'	E3
23'-31'	G3.5	15' < 20'	F5
		20' < 23'	F3.5
		23'-31'	G3.5
SIZE: 9' x 9'			
≥0.5' < 8'	D7	≥0.5' < 7'	D4
8' < 14'	E5	7' < 10'	E5
14' < 22'	F5	10' < 17'	F3.5
		17' < 22'	G3.5
SIZE: 9'x9'x10" SLAB THICKNESS			
22' < 36'	F5	22' < 31'	F3.5
36'-40'	G5	31'-40'	G3.5
SIZE: 10'x10'x10" SLAB THICKNESS			
≥0.5' < 7'	C6.5	0.5' < 6'	C6.5
7' < 10'	D7	6' < 9'	D4.5
10' < 18'	E5	9' < 15'	E5
18' < 27'	F5	15' < 22'	F5
27'-32'	G5	22'-32'	G3.5
SIZE: 12'x12'x12" SLAB THICKNESS			
≥0.5' < 10'	D7	≥0.5' < 8'	D7
10' < 16'	E5	8' < 14'	E5
16' < 25'	F5	14' < 22'	F5
25'-35'	G5	22' < 30'	G5
		30'-35'	H4

SLAB DEPTH	SLAB THICKNESS	REINF. (2-WAY) SCHEDULE
SIZE: 3'-6" DIAMETER		
2'-15'	6" Precast	C6.5
0.5' < 30'	8"	A6
30'-40'	8"	B5.5
SIZE: 4'-0" DIAMETER		
≥0.5' < 19'	8"	A6
19' < 30'	8"	B5.5
30'-40'	8"	C6.5
SIZE: 5'-0" DIAMETER		
≥0.5' < 15'	8"	B5.5
15' < 26'	8"	C6.5
26' < 35'	8"	D7
35'-40'	8"	D4.5
SIZE: 6'-0" DIAMETER		
≥0.5' < 9'	8"	B5.5
9' < 15'	8"	C6.5
15' < 22'	8"	C3.5
22' < 30'	8"	D4.5
30'-40'	8"	E5
SIZE: 7'-0" DIAMETER		
≥0.5' < 8'	8"	C3.5
8' < 16'	8"	D4.5
16' < 23'	8"	E5
23' < 27'	8"	E3
27'-40'	8"	F3.5
SIZE: 8'-0" DIAMETER		
≥0.5' < 10'	8"	D4.5
10' < 16'	8"	E5
16' < 19'	8"	E3
19' < 29'	8"	F3.5
29'-40'	10"	F5
SIZE: 10'-0" DIAMETER		
≥0.5' < 12'	10"	D4.5
12' < 20'	10"	E5
20' < 28'	10"	F5
28'-40'	10"	G3.5
SIZE: 12'-0" DIAMETER		
≥0.5' < 8'	10"	D4.5
8' < 13'	10"	E5
13' < 18'	10"	F5
18' < 26'	10"	G3.5
26'-40'	12"	G3.5

SLAB AND WALL DESIGN TABLE NOTES

- Size is the inside dimension(s) of a structure.
- Slab reinforcement is appropriate for top, intermediate, and bottom slabs.
- Bottom Slabs for precast 3'-6" x 3'-6" rectangular structures at 15' depth or less, may be 6" thick.
- Slab depth is measured from finished grade to top of slab.
- Wall depth is measured to the top of the bottom slab for boxes and to the top of the intermediate slab for risers.
- Wall height is the distance between top of lower slab to bottom of upper slab. Maximum wall height is 12' for wall lengths exceeding 5', or 10' for wall lengths exceeding 12'.
- Wall lengths exceeding 6'-0" require two layers of reinforcing (See Table 8) with 2" of cover from the horizontal bars to the inside and outside faces for each layer.
- Wall lengths exceeding the dimensions or depths shown in Table 8, or 12'-0" diameter require a special design.
- Wall thickness and reinforcing for rectangular structures is based on the longer wall length.
- Reinforcing schedules with larger areas of steel may be substituted for schedules with smaller bar or wire spacing, except that Schedule B10 may not be substituted for Schedule A6. See Index 425-001 for allowable bar spacing adjustments when larger areas of reinforcing are substituted.

10/30/2018 8:43:06 AM

WALL DESIGNS - RECTANGULAR STRUCTURES (TABLE 8)

VERTICAL REINFORCING		HORIZONTAL REINFORCING		WALL THICKNESS	
WALL DEPTH	SCHEDULE	WALL DEPTH	SCHEDULE		
SIZE: 3'-6" & RISERS					
≥1.17' - 40'	A12	≥1.17' < 10'	B10	6"/8"	
		10' < 18'	B5.5	6"/8"	
		18' < 29'	C6.5	6"/8"	
		29' - 40'	C3.5	6"/8"	
SIZE: 4'-0"					
≥1.17' - 40'	A12	≥1.17' < 6'	B10	6"/8"	
		6' < 10'	B5.5	6"/8"	
		10' < 20'	C6.5	6"/8"	
		20' < 28'	C3.5	6"/8"	
		28' - 40'	D4.5	6"/8"	
SIZE: 5'-0"					
≥1.17' - 40'	A12	≥1.17' < 5'	B5.5	6"/8"	
		5' < 9'	C6.5	6"/8"	
		9' < 15'	C3.5	6"/8"	
		15' < 22'	D4.5	6"/8"	
		22' - 40'	E3	8"	
SIZE: 6'-0"					
≥1.17' < 26'	A12	≥1.17' < 9'	C3.5	6"/8"	
		9' < 15'	D4.5	6"/8"	
		15' < 26'	E3	8"	
	Inside	Outside	Inside	Outside	
26' - 40'	A12	A12	D7	D7	8"
SIZE: 7'-0"					
	Inside	Outside	Inside	Outside	
≥1.17' < 25'	A12	A12	B10	B10	8"
26' - 40'	B10	B10	B5.5	B5.5	8"
			C6.5	C6.5	8"
			D7	D7	8"
			E5	E5	8"
SIZE: 8'-0"					
	Inside	Outside	Inside	Outside	
≥1.17' < 20'	A12	A12	B5.5	B5.5	8"
20' - 40'	C6.5	C6.5	C6.5	C6.5	8"
			D7	D7	8"
			E5	E5	8"
			F5	F5	8"
SIZE: 9'-0"					
	Inside	Outside	Inside	Outside	
≥1.17' < 12'	A12	A12	C6.5	C6.5	8"
12' < 28'	C6.5	C6.5	D7	D7	8"
28' - 40'	D7	D7	E5	E5	8"
			F5	F5	8"
SIZE: 10'-0"					
	Inside	Outside	Inside	Outside	
≥1.17' < 10'	B10	B10	D7	D7	8"
10' < 21'	C6.5	C6.5	E5	E5	8"
21' < 26'	D7	D7	F5	F5	8"
26' - 40'	C6.5	C6.5	F5	F5	10"

VERTICAL REINFORCING		HORIZONTAL REINFORCING		WALL THICKNESS		
WALL DEPTH	SCHEDULE	WALL DEPTH	SCHEDULE			
SIZE: 10'-0" (Precast Only)						
	Inside	Outside	Inside	Outside		
26' - 40'	D7	D7	F5	F5	9"	
SIZE: 12'-0"						
	Inside	Outside	Inside	Outside		
≥1.17' < 14'	B10	B10	≥1.17' < 10'	C6.5	C6.5	10"
14' < 25'	C6.5	C6.5	10' < 17'	D7	D7	10"
25' - 40'	D7	D7	17' < 24'	E5	E5	10"
			24' - 40'	F5	F5	10"
SIZE: 12'-0" (Precast Only)						
	Inside	Outside	Inside	Outside		
≥1.17' < 12'	B10	B10	≥1.17' < 10'	D7	D7	9"
12' < 24'	C6.5	C6.5	10' < 17'	D4.5	D4.5	9"
24' - 40'	D7	D7	17' < 23'	E5	E5	9"
			23' < 32'	F5	F5	9"
			32' - 40'	G5	G5	9"
SIZE: 16'-0"						
	Inside	Outside	Inside	Outside		
≥1.17' < 11'	C6.5	C6.5	≥1.17' < 13'	D7	D7	10"
11' < 20'	D7	D7	13' < 20'	E5	E5	10"
20' < 28'	E5	E5	20' < 28'	F5	F5	10"
28' - 40'	F5	F5	28' - 40'	G5	G5	10"
SIZE: 16'-0" (Precast Only)						
	Inside	Outside	Inside	Outside		
≥1.17' < 10'	C6.5	C6.5	≥1.17' < 9'	D7	D7	9"
10' < 18'	D7	D7	9' < 13'	D4.5	D4.5	9"
18' < 25'	E5	E5	13' < 19'	E5	E5	9"
25' - 35'	F5	F5	19' < 27'	F5	F5	9"
			27' - 35'	G5	G5	9"
SIZE: 20'-0"						
	Inside	Outside	Inside	Outside		
≥1.17' < 10'	C6.5	C6.5	≥1.17' < 8'	D7	D7	10"
10' < 17'	D7	D7	8' < 12'	E5	E5	10"
17' - 30'	E5	E5	12' < 20'	F5	F5	10"
			20' - 30'	G5	G5	10"
SIZE: 20'-0" (Precast Only)						
	Inside	Outside	Inside	Outside		
≥1.17' < 8'	C6.5	C6.5	≥1.17' < 8'	D4.5	D4.5	9"
8' < 13'	D7	D7	8' < 12'	E5	E5	9"
13' - 25'	E5	E5	12' < 19'	F5	F5	9"
			19' - 25'	G5	G5	9"

REINFORCING SCHEDULE				
SCHEDULE	GRADE 60 BARS OR 65 KSI & 70 KSI WELDED WIRE REINFORCING			
	GRADE 60 AREA (in. ² /ft.)	MAXIMUM SPACING		
		GR 60 BARS (in.)	65 KSI (in.)	70 KSI (in.)
A12	0.20	12	8	8
A6	0.20	6	5	4½
B10	0.24	10	8	7½
B5.5	0.24	5½	5	4
C6.5	0.37	6½	6	5
C3.5	0.37	3½	3	2½
D7	0.53	7	6	5
D4.5	0.53	4½	4	3½
E5	0.73	5	4	4
E3	0.73	3	3	3
F5	1.06	5	4	4
F3.5	1.06	3½	3	3
G5	1.45	5	4	4
G.3.5	1.45	3½	3	3
H4	1.75	4	3	3

*Equivalent Area Welded Wire Reinforcing may be substituted in accordance with Index 425-001.

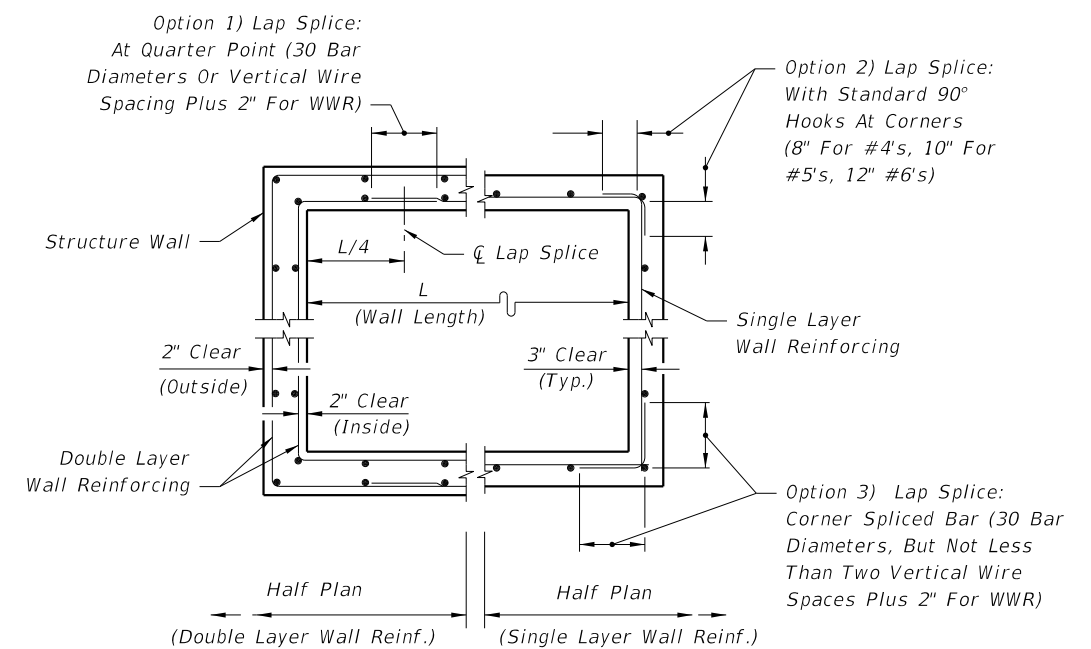

WALL REINFORCING SPLICE DETAILS (ALTERNATE B)

10/30/2018 8:43:09 AM

LAST REVISION 11/01/17	DESCRIPTION:
---------------------------	--------------



FY 2019-20
STANDARD PLANS

STRUCTURE BOTTOMS TYPE J AND P

INDEX
425-010

SHEET
5 of 5

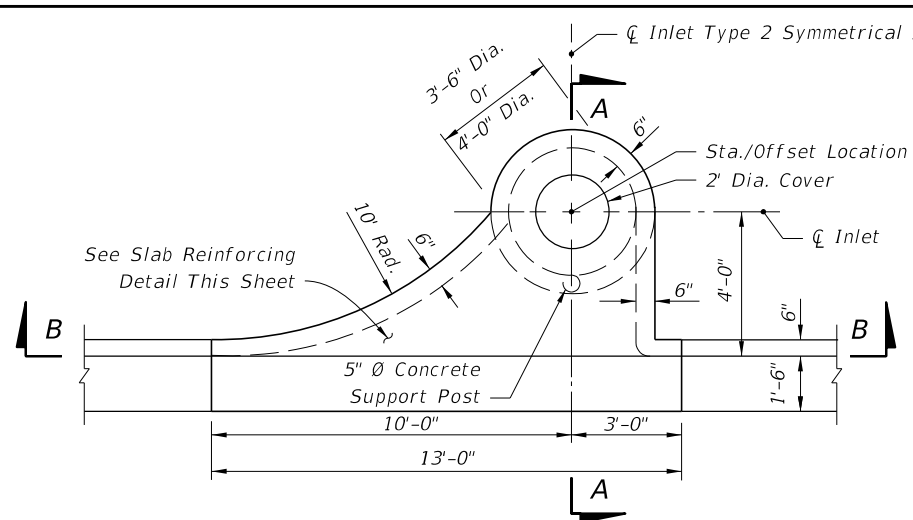

PLAN (INLET TYPE 2 SYMMETRICAL ABOUT CL)

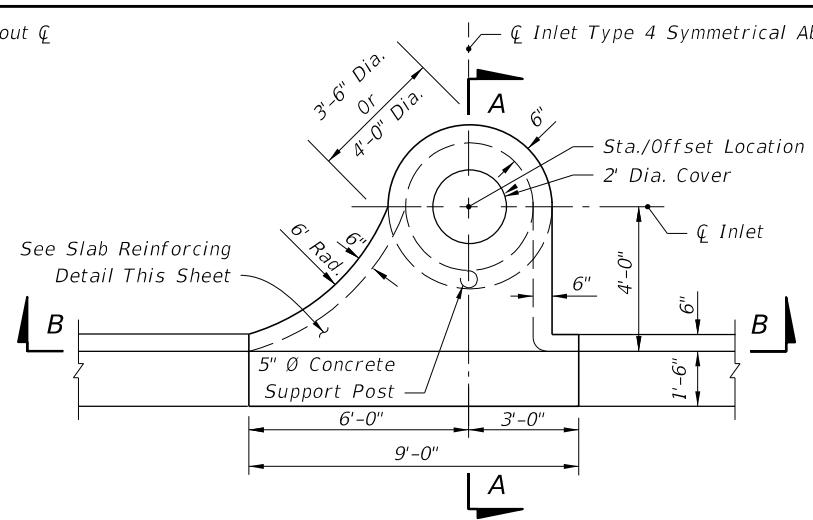

PLAN (INLET TYPE 4 SYMMETRICAL ABOUT CL)

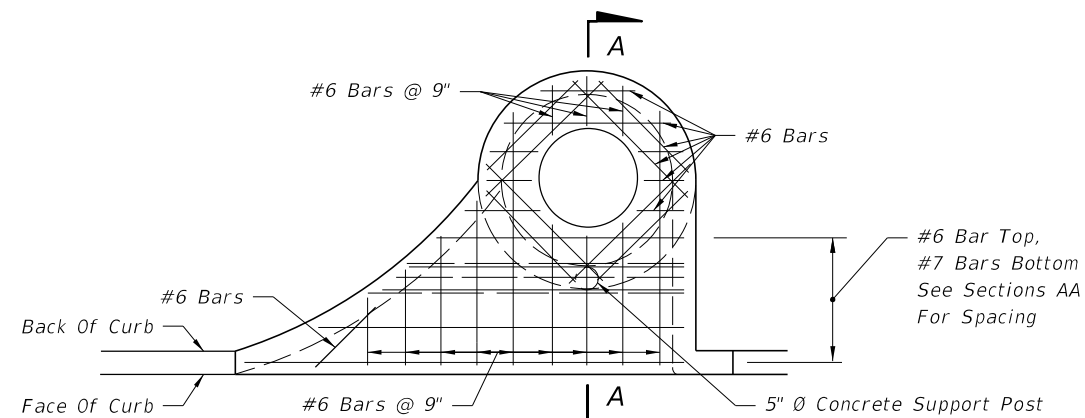

INLETS TYPES 1 AND 3

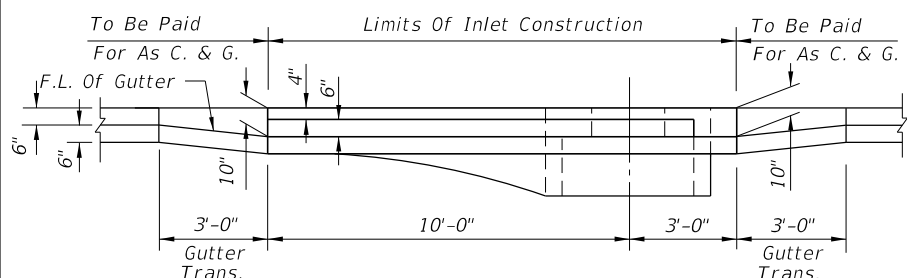

SECTION BB (INLET TYPE 2 SYMMETRICAL ABOUT CL)
INLETS TYPES 1 AND 2

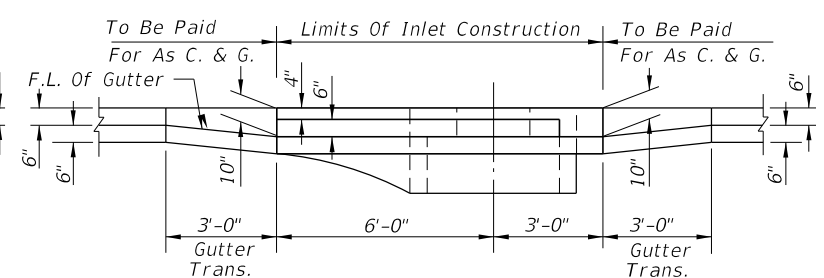

SECTION BB (INLET TYPE 4 SYMMETRICAL ABOUT CL)
INLETS TYPES 3 AND 4

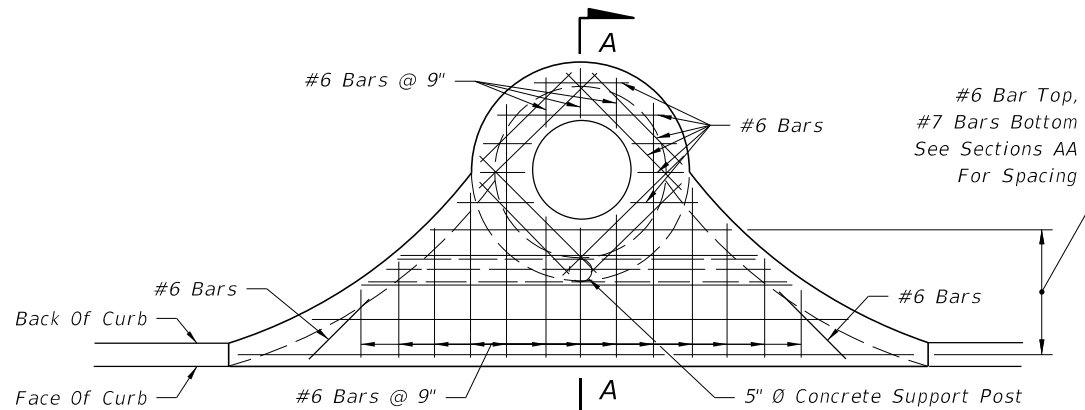

INLETS TYPES 2 AND 4
SLAB REINFORCING

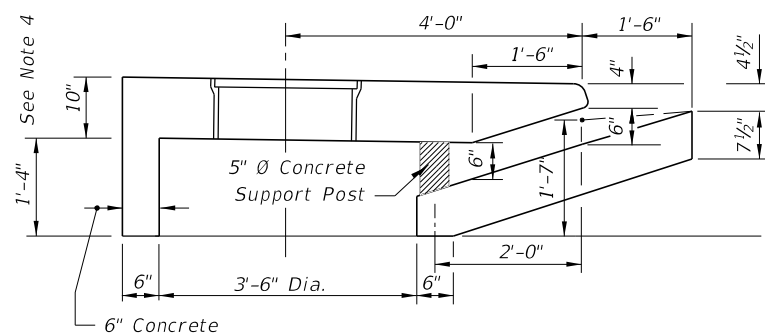

DIMENSIONAL SECTION

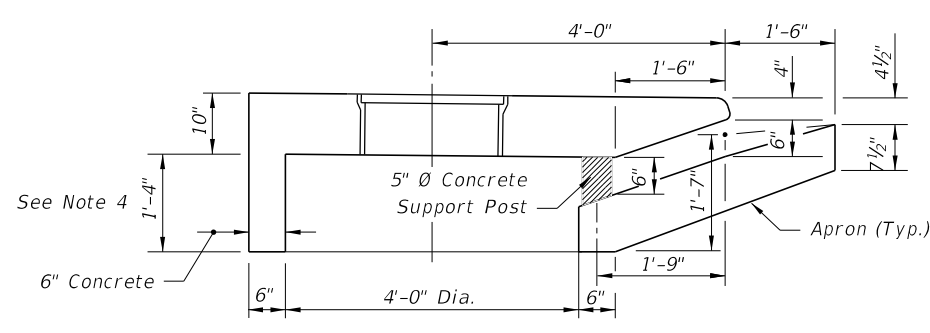

DIMENSIONAL SECTION

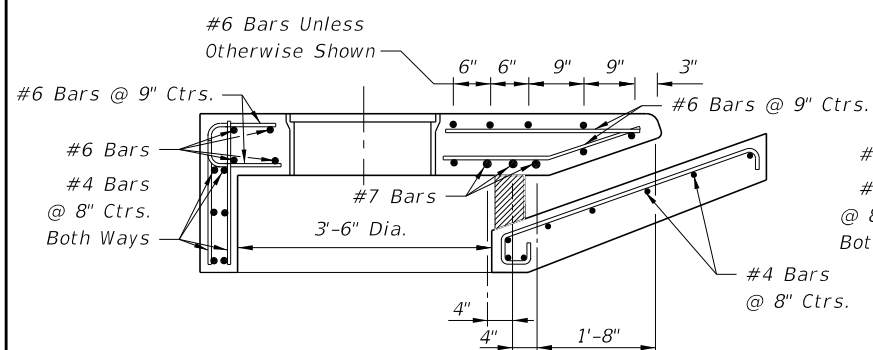

REINFORCING SECTION
3'-6" DIA. STRUCTURE BOTTOM (SECTION AA)

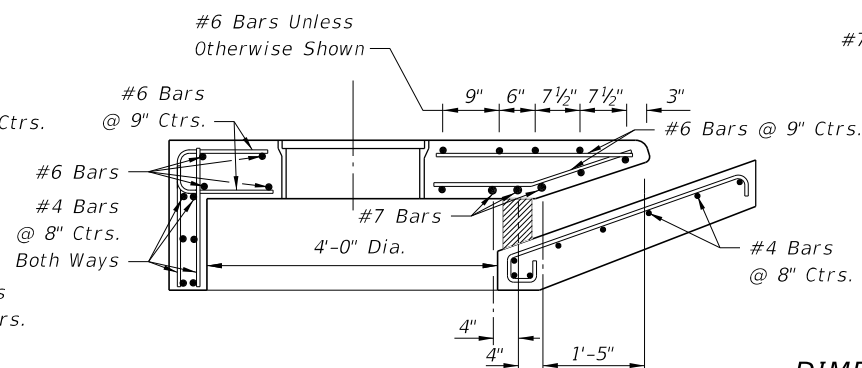

REINFORCING SECTION
4'-0" DIA. STRUCTURE BOTTOM (SECTION AA)

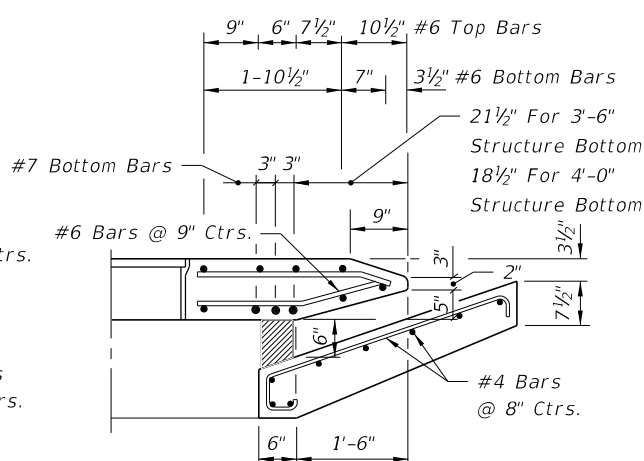

DIMENSION & REINFORCING HALF SECTION
TYPES A & E CURB (HALF SECTION AA)
(TYPE E GUTTER SHOWN)

GENERAL NOTES

1. The finished grade and slope of the inlet tops are to conform with the finished cross slope and grade of the proposed sidewalk and/or border.
2. When inlets are to be constructed on a curve, refer to the plans to determine the radius and, where necessary, modify the inlet details accordingly. Bend steel when necessary.
3. All steel in inlet top shall have 1/4" minimum cover unless otherwise shown. Inlet tops shall be either cast-in-place or precast concrete.
4. For precast units the rear wall and apron may be precast as a separate piece from the top slab. Provide a minimum of 7 ~ #4 dowels in accordance with Index 425-001 "OPTIONAL CONSTRUCTION JOINTS".
5. For supplemental details see Index 425-001.
6. Only round concrete support post will be acceptable.
7. These inlets are designed for use with standard curb and gutter Types E and Type F. Locate inlet outside of pedestrian crosswalks.
8. For structure bottoms see Index 425-010.
9. Inlet to be paid for under the contract unit price for inlets (Curb) (Type), Each.

10/30/2018 8:43:16 AM

TRANSVERSE SECTIONS FOR INLETS TYPES 1, 2, 3 & 4

LAST REVISION	DESCRIPTION:
11/01/17	



FY 2019-20
STANDARD PLANS

CURB INLET TOPS TYPES 1, 2, 3 AND 4

INDEX
425-020

SHEET
1 of 1

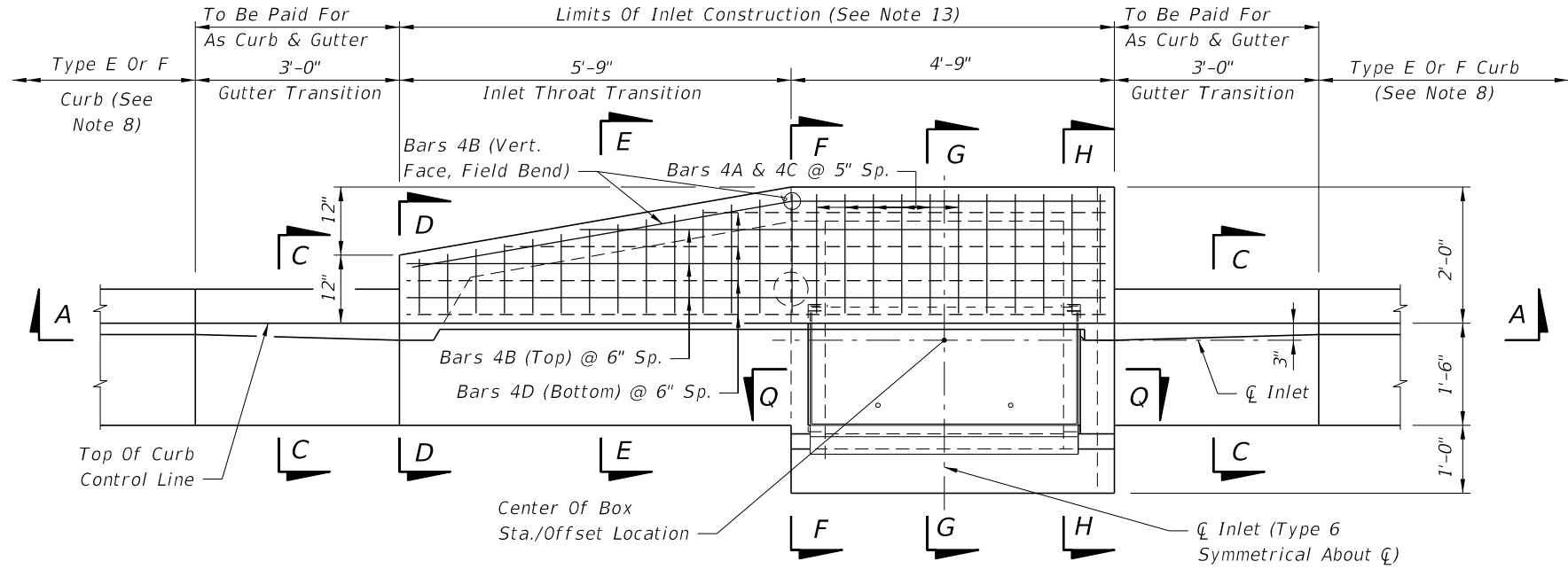

TOP VIEW

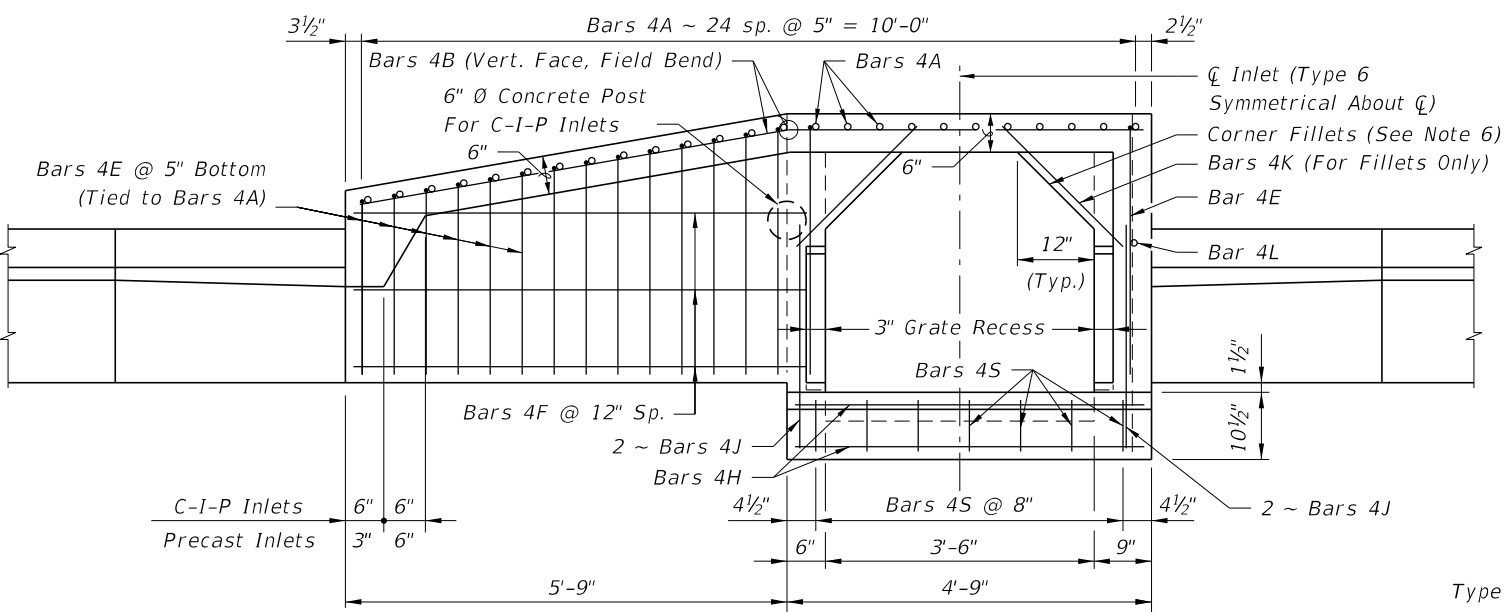

SECTION BB

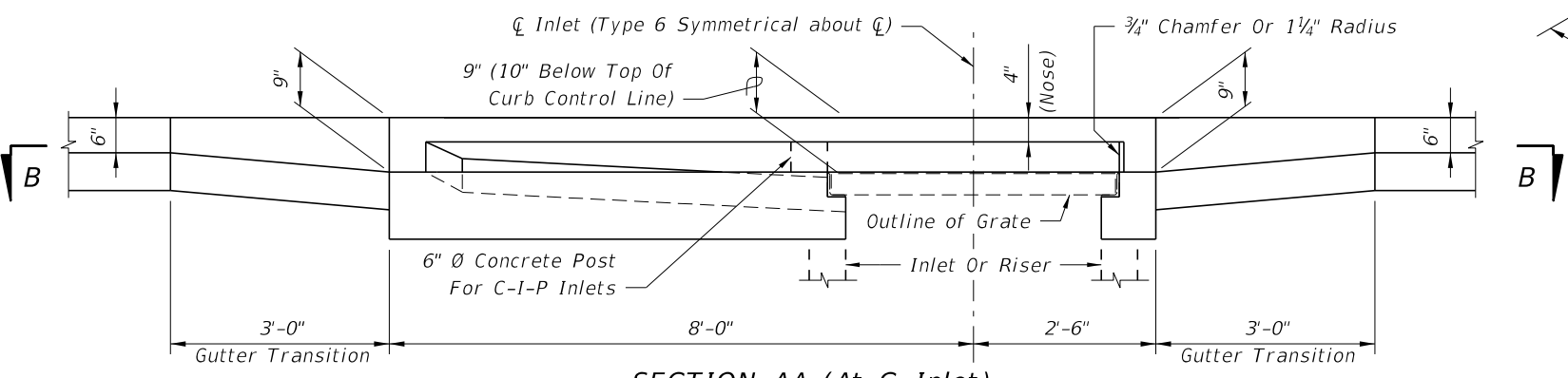

SECTION AA (At Q Inlet)

INLET TYPE 5 (Curb Inlet Type 6 Symmetrical With Left Half)

GENERAL NOTES

1. The finished grade and slope of the inlet tops are to conform with the finished cross slope and grade of the proposed sidewalk and/or border.
2. For inlets constructed on a curve, refer to the plans to determine the radius, and modify the inlet details accordingly. Bend steel when necessary.
3. All reinforcing steel to be Grade 60 bars with 1 1/4" minimum cover unless otherwise shown, see Sheet 4 for equivalent area Welded Wire Reinforcement details.
4. Inlet tops shall be either cast-in-place or precast concrete. Precast units shall conform to the dimensions shown or in accordance with approved shop drawings. Request for shop drawing approval shall be directed to the State Drainage Engineer.
5. Concrete meeting the requirements of ASTM C478 (4,000 psi) may be used in lieu of Class II concrete for precast units, manufactured in plants which meet the requirements of Section 449 of the Specifications.
6. Corner fillets are required at inlet opening for precast units or C-I-P units used in conjunction with circular inlet bottoms or skewed rectangular inlet boxes. Finish top of fillets flush with drain throat bottom and match slope.
7. For inlet bottoms see Index 425-010. Inlet tops are to be used with Type P bottoms, or Type J bottoms with 3'-6" square (Type B), 3'-6" or 4' round (Type A) risers or top slab openings.
8. These inlet tops are designed for use with standard curb and gutter Type E and Type F. Locate inlet outside of pedestrian crosswalks. For Type E curb, transition the shape of the curb over the gutter transition length to match the face of the inlet (Type F).
9. See Index 425-001 for supplemental details.
10. All steel used for frame and grate shall meet the requirements of ASTM A36/A36M.
11. Either cast iron grates or steel grates may be used.
12. When Alternate "G" grate is specified in the plans either the cast iron grate and galvanized steel frame or the the galvanized steel grate and frame must be used. Grates are to be grouted in accordance with the grouting detail shown on Sheet 5, in lieu of tack welding.
13. Inlet to be paid for under the contract unit price for Inlets (Curb) (Type _), Each.

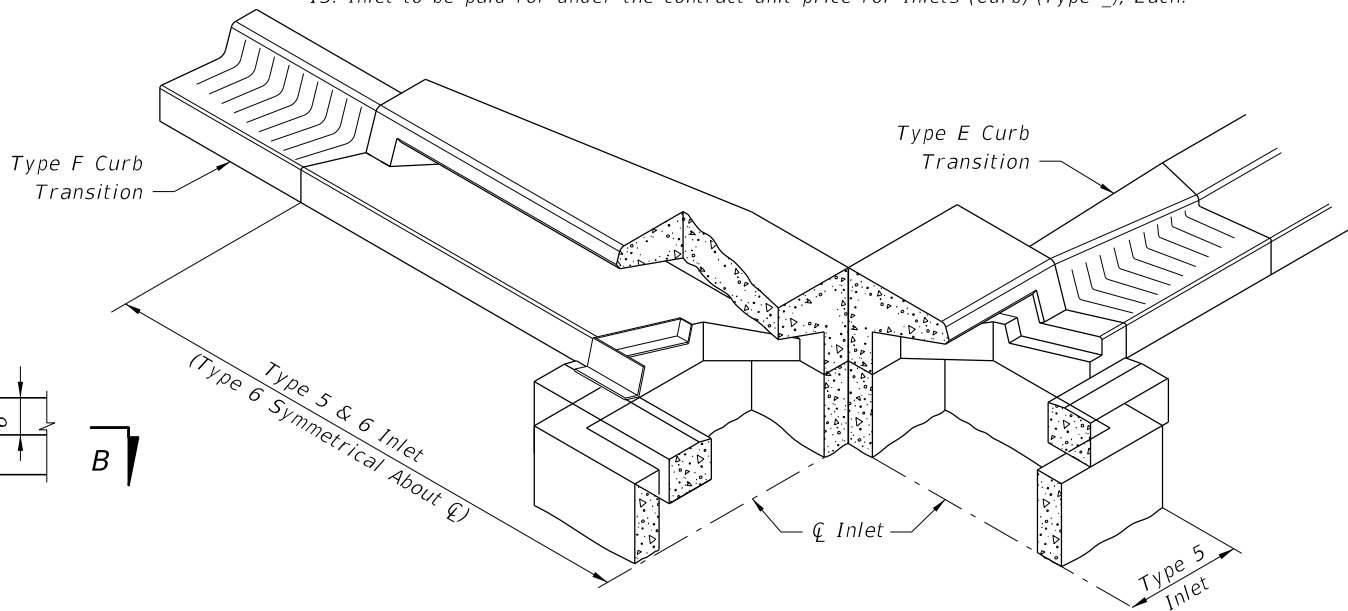

SKETCH SHOWING FRAME SEAT AND THROAT RECESS

10/30/2018 8:43:25 AM

LAST REVISION 11/01/17	DESCRIPTION:	 FY 2019-20 STANDARD PLANS	CURB INLET TOPS TYPES 5 AND 6	INDEX 425-021	SHEET 1 of 5
---------------------------	--------------	----------------------------------------------------------------------------------------------------------------------	-------------------------------	------------------	-----------------

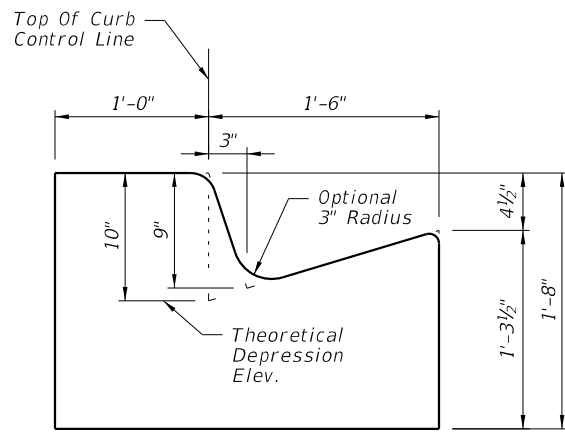

SECTION DD
(End View Of Inlet)

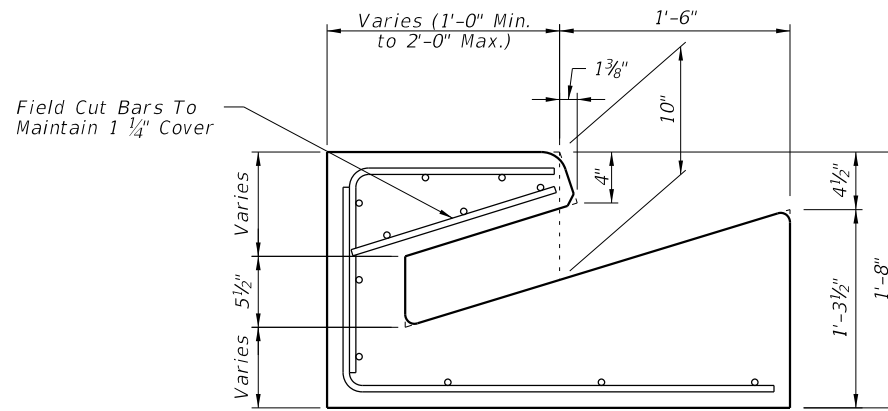

SECTION EE

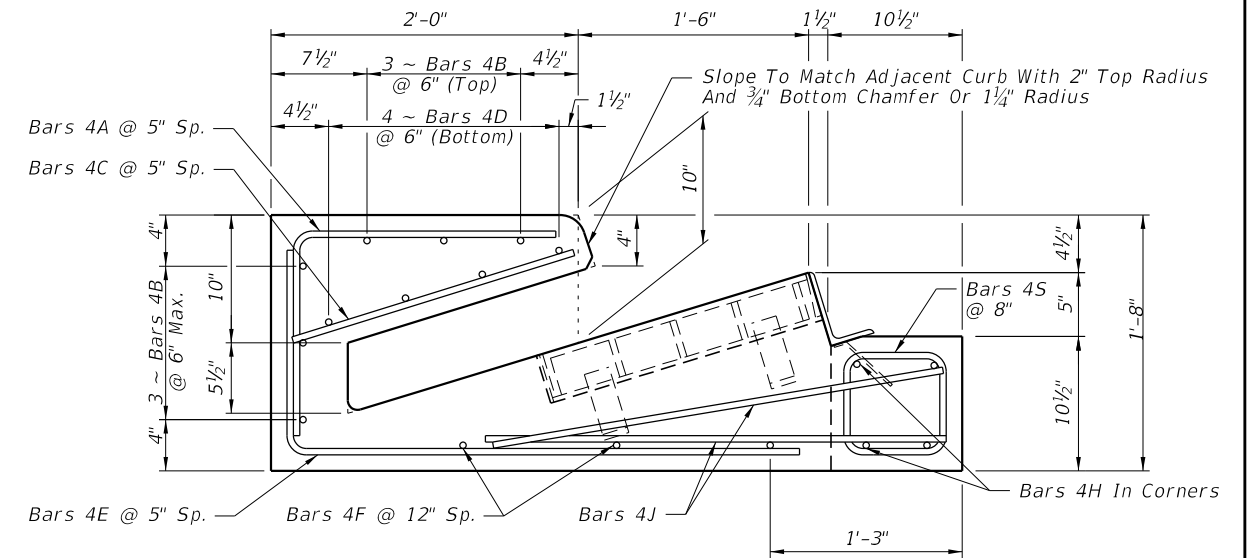

SECTION FF

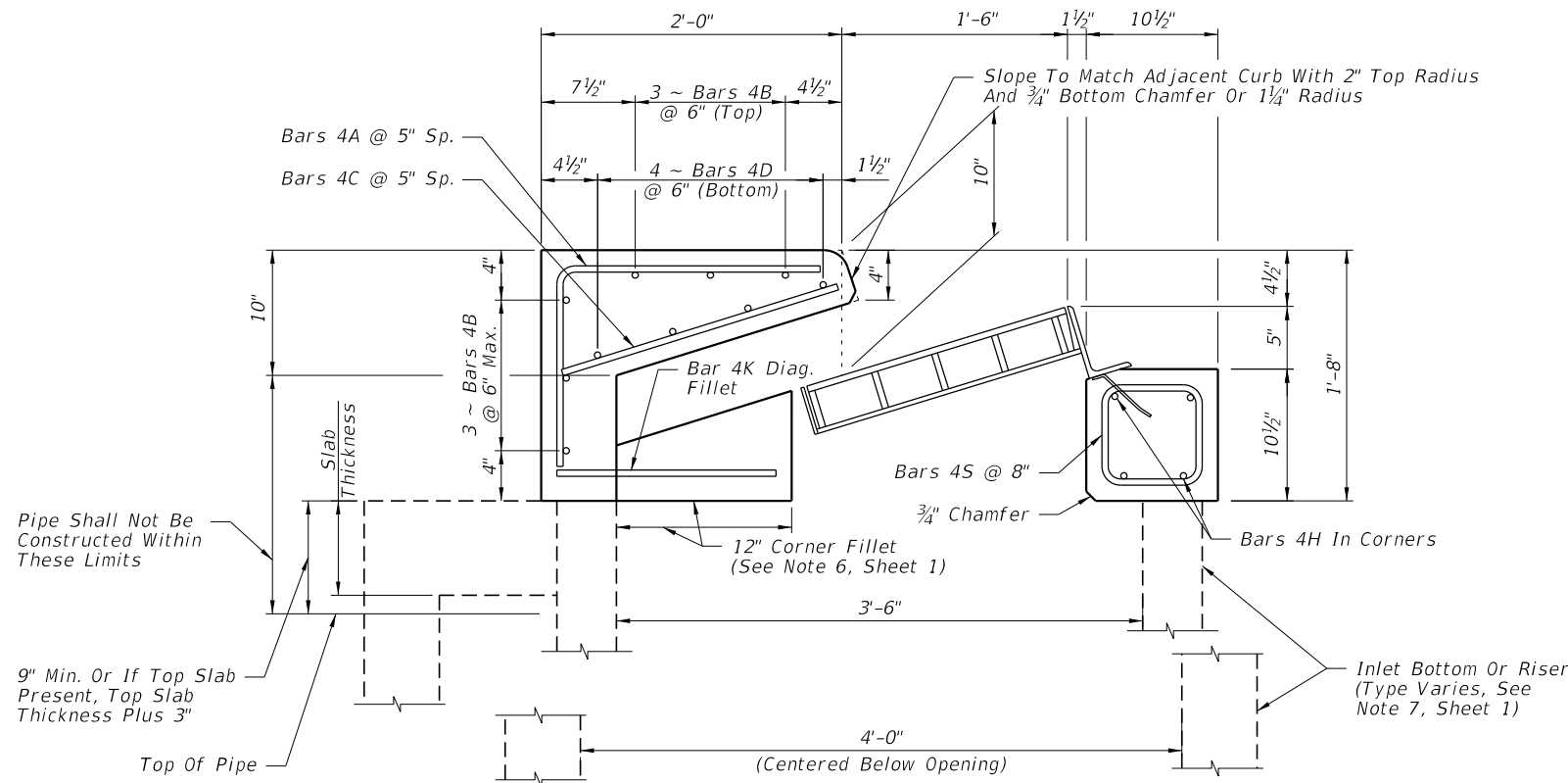

SECTION GG

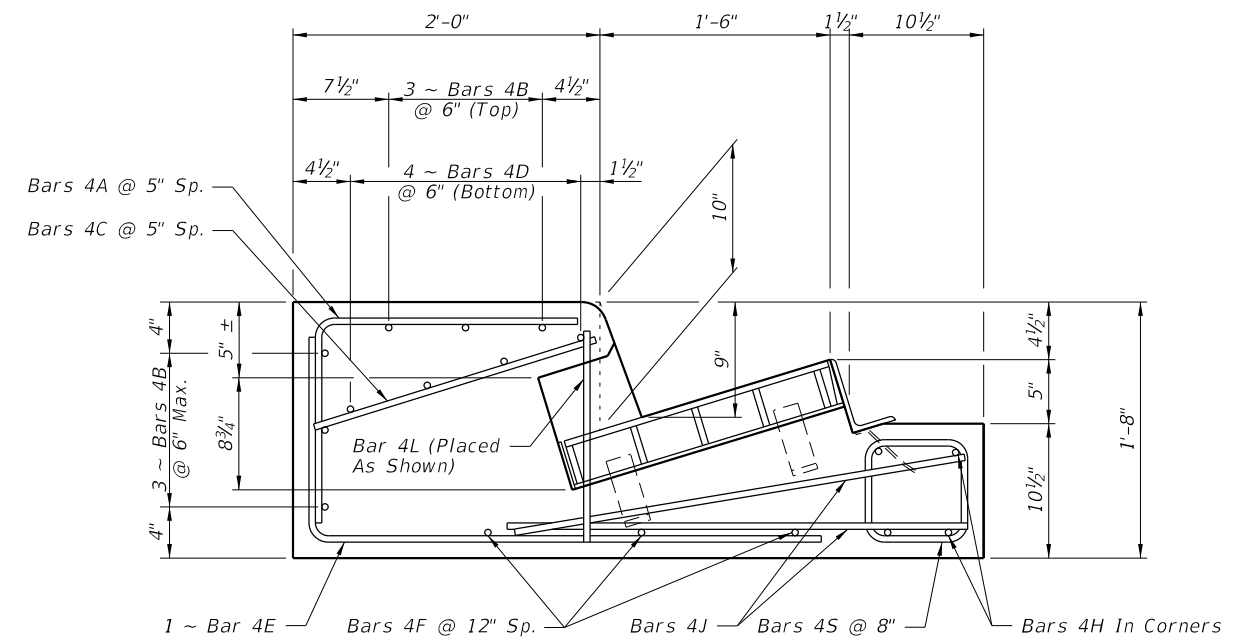

SECTION HH
(Type 5 Inlet Only)

CROSS REFERENCES:
For General Notes See Sheet 1.
For Location Of Sections DD
Thru HH See Sheet 1.

PRECAST DETAILS

10/30/2018 8:43:33 AM

LAST REVISION 11/01/17	DESCRIPTION:
---------------------------	--------------



FY 2019-20
STANDARD PLANS

CURB INLET TOPS TYPES 5 AND 6

INDEX
425-021

SHEET
2 of 5

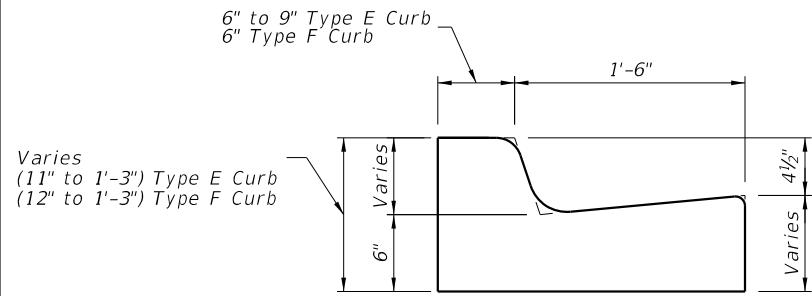

SECTION CC
(Gutter Transition
Type F Shown, Type E Similar)

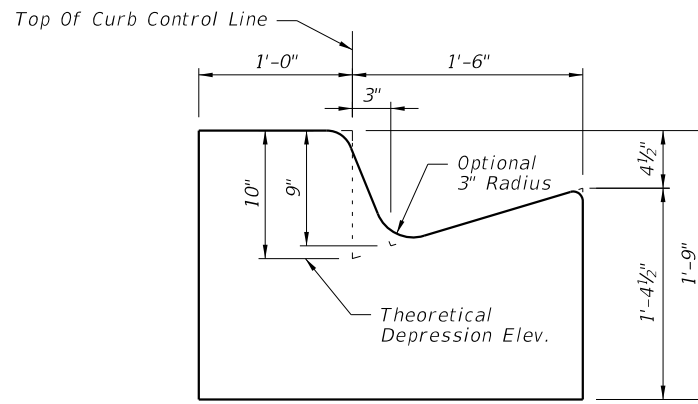

SECTION DD (OPTION A)
(End View Of Inlet)

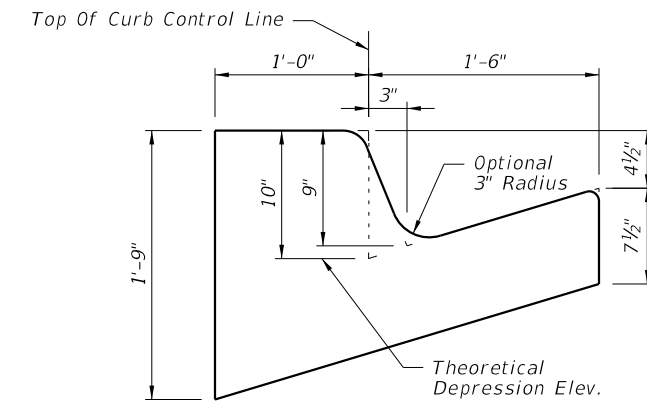

SECTION DD (OPTION B)
(End View Of Inlet)

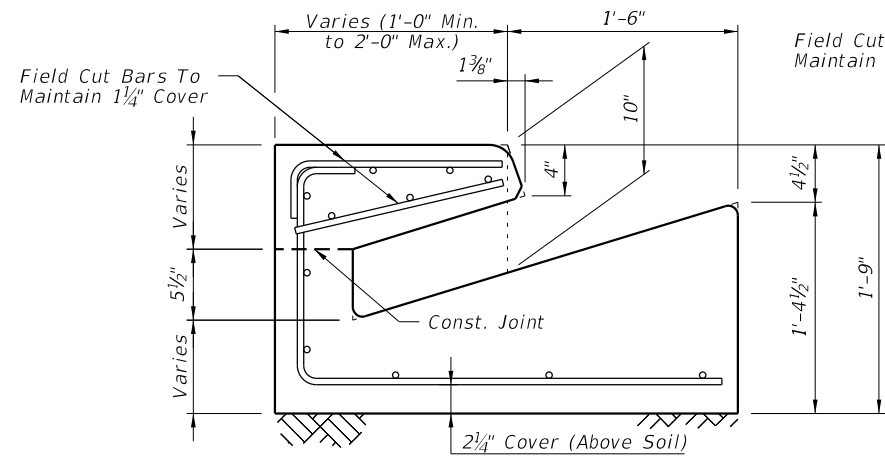

SECTION EE (OPTION A)

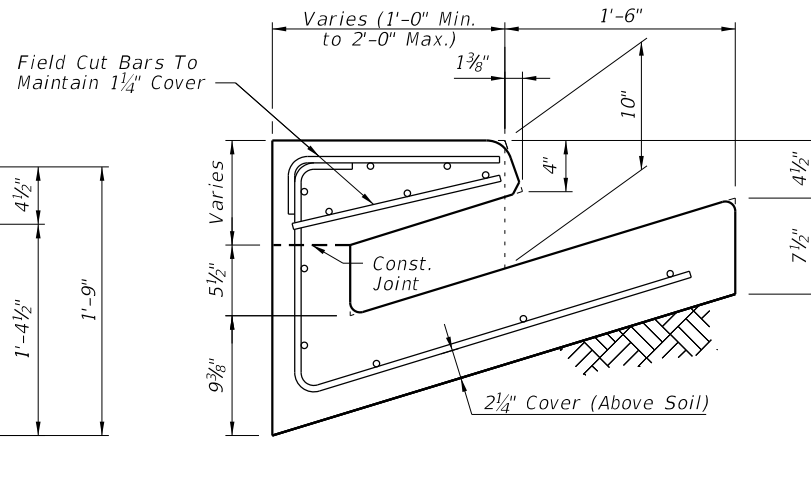

SECTION EE (OPTION B)

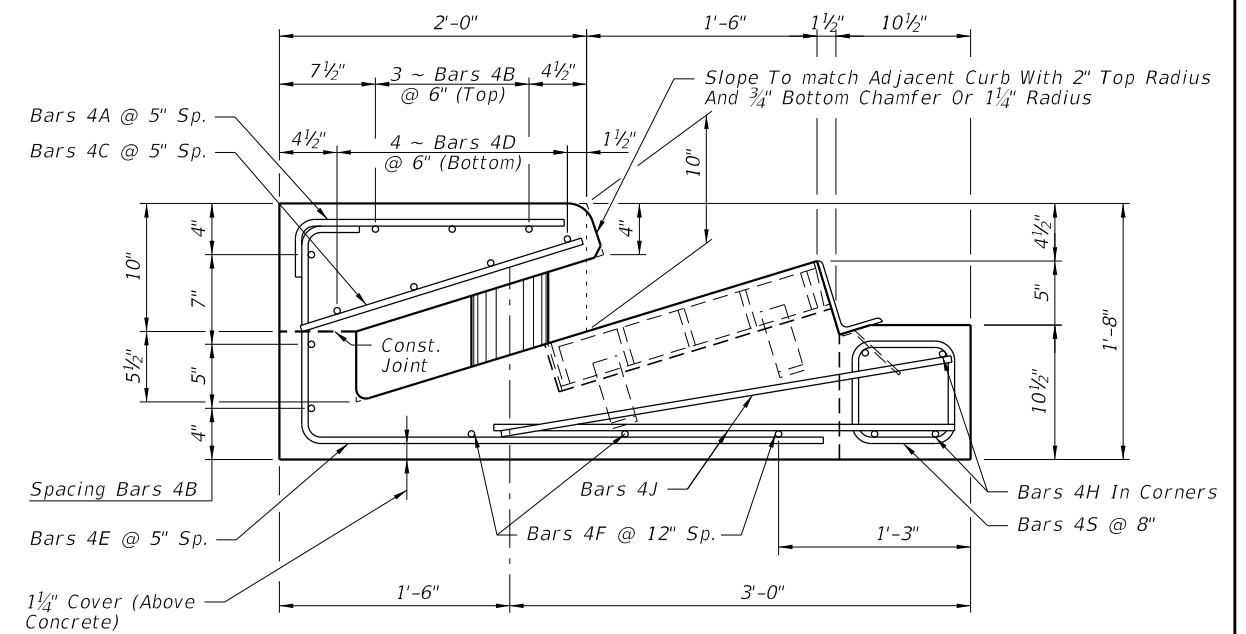

SECTION FF

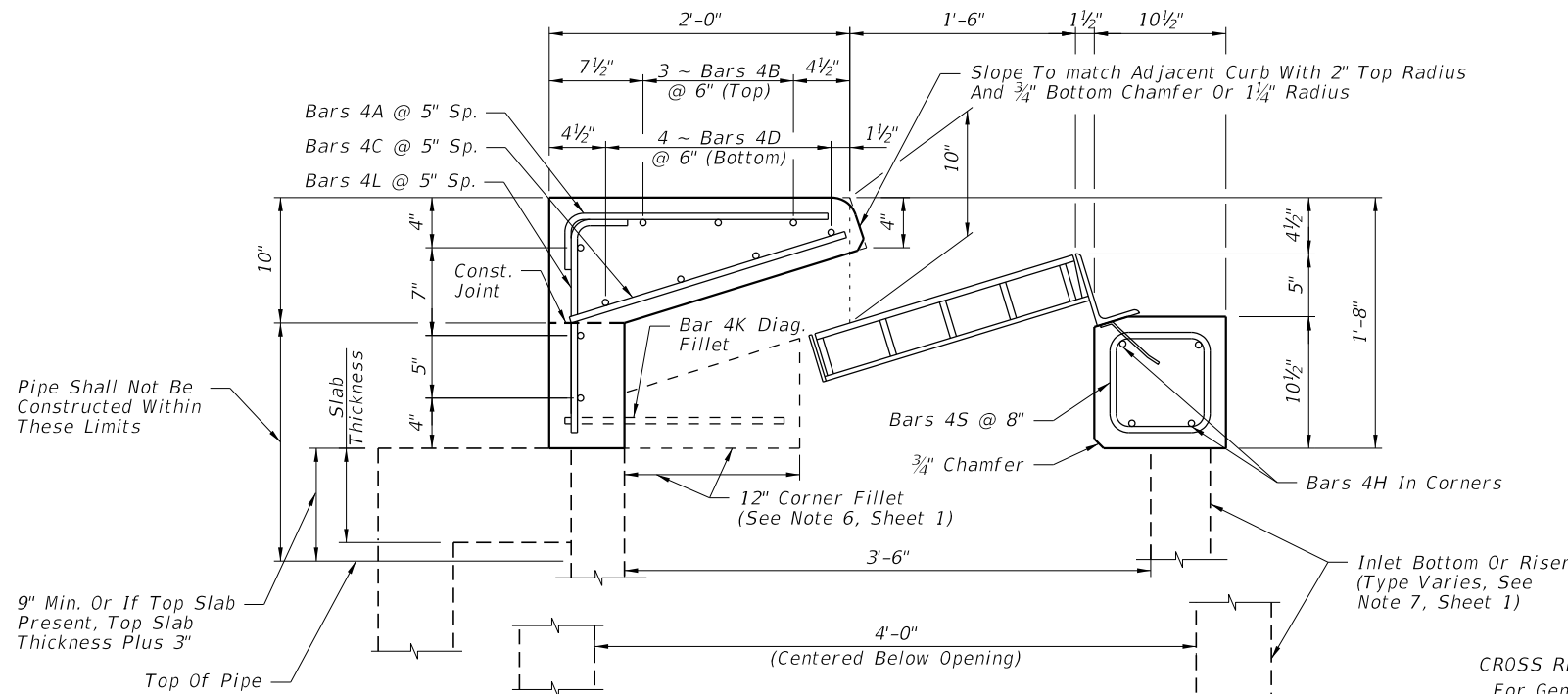

SECTION GG

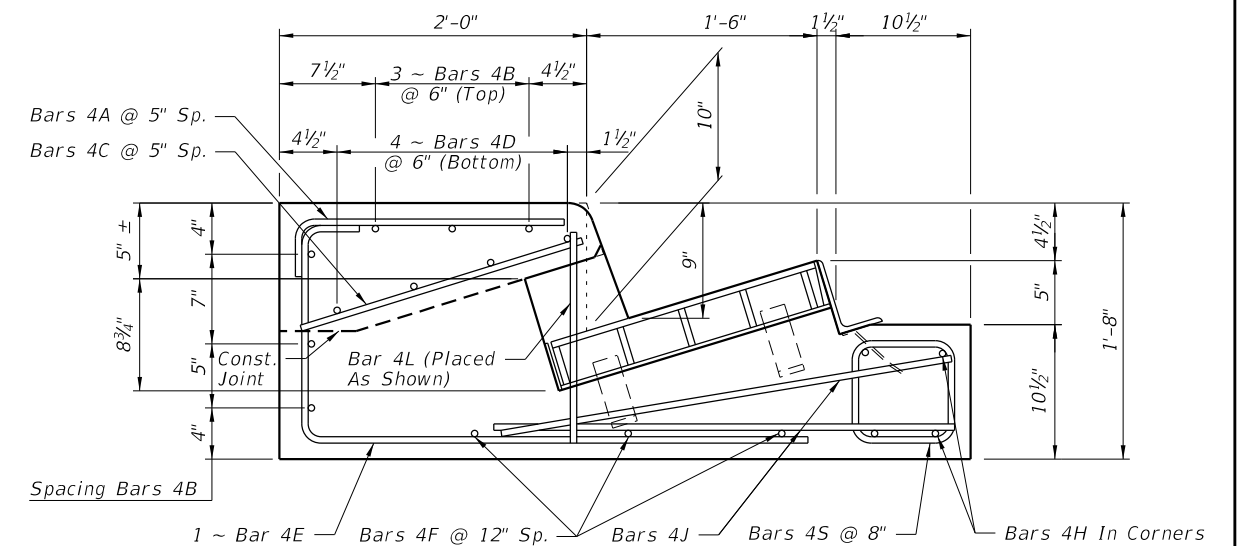

SECTION HH (Type 5 Inlet Only)

CROSS REFERENCES:
For General Notes See Sheet 1.
For Location Of Sections CC Thru HH See Sheet 1.

CAST-IN-PLACE DETAILS

10/30/2018 8:43:36 AM

LAST REVISION 11/01/17	DESCRIPTION:
---------------------------	--------------



FY 2019-20
STANDARD PLANS

CURB INLET TOPS TYPES 5 AND 6

INDEX
425-021

SHEET
3 of 5

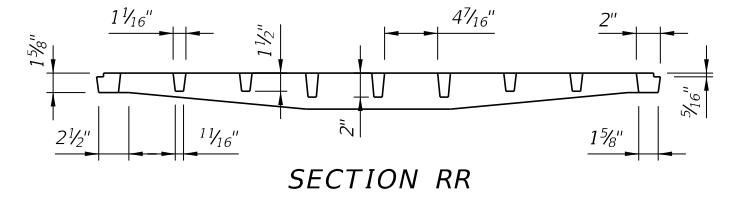
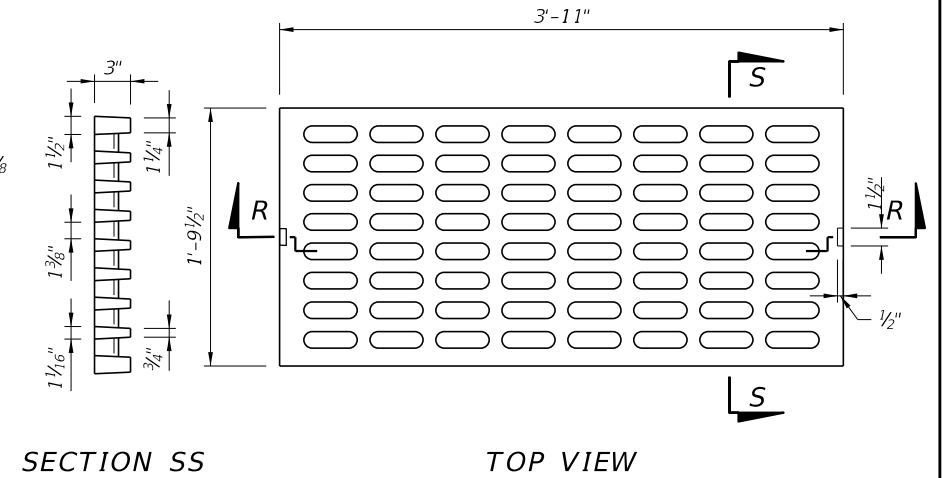
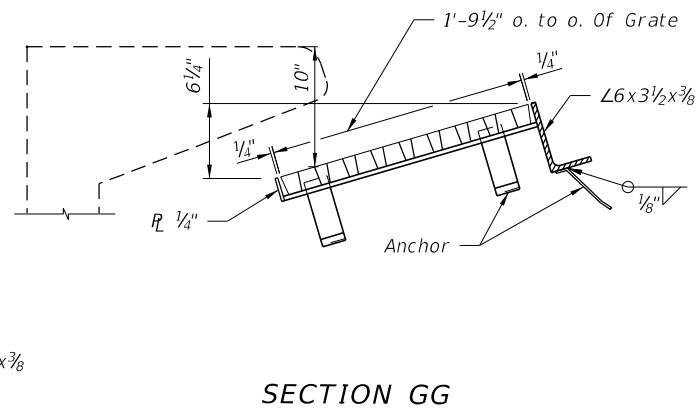
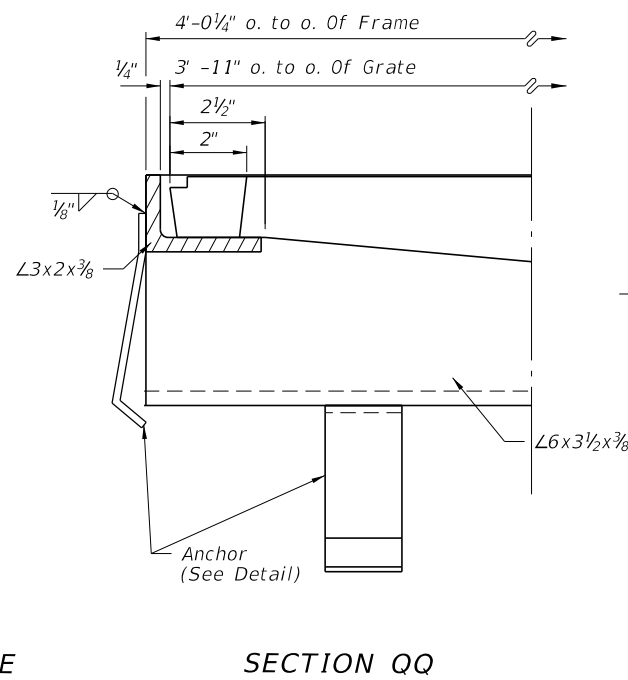
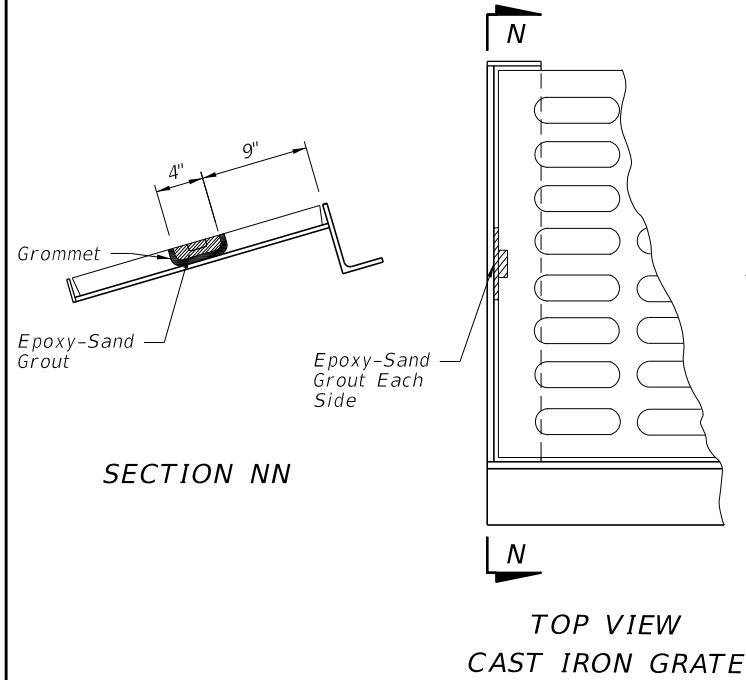

CAST IRON GRATE

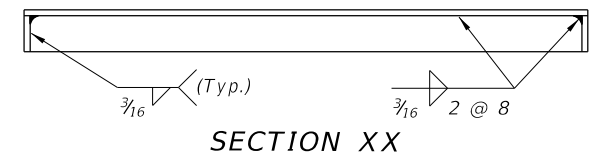
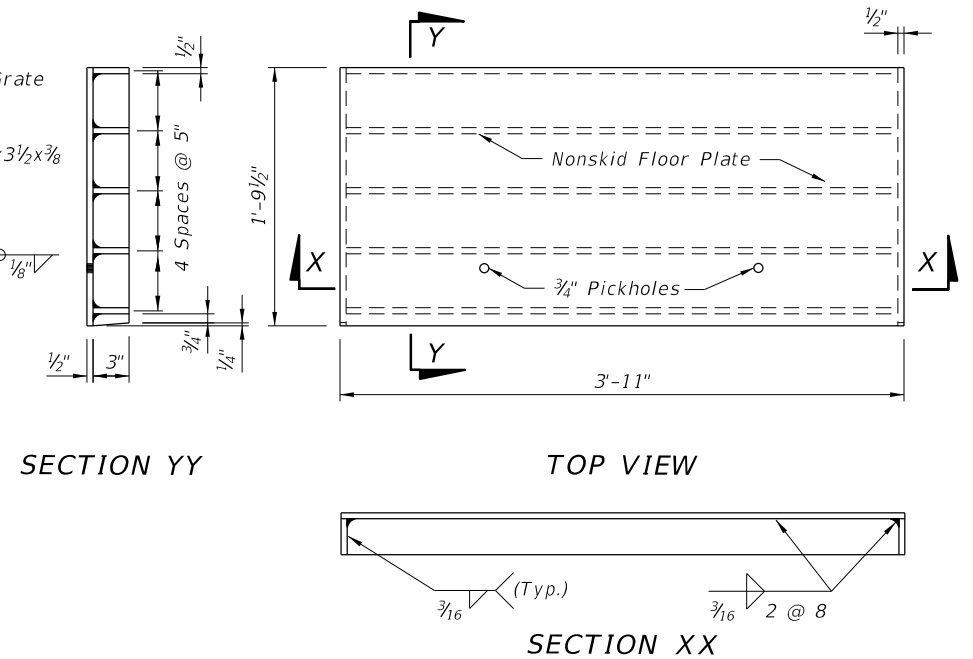
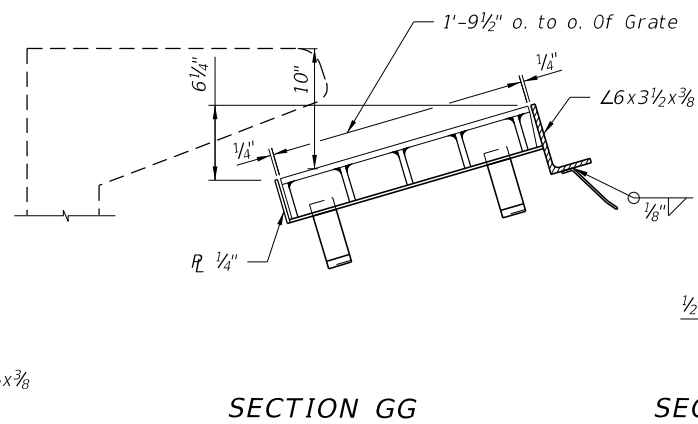
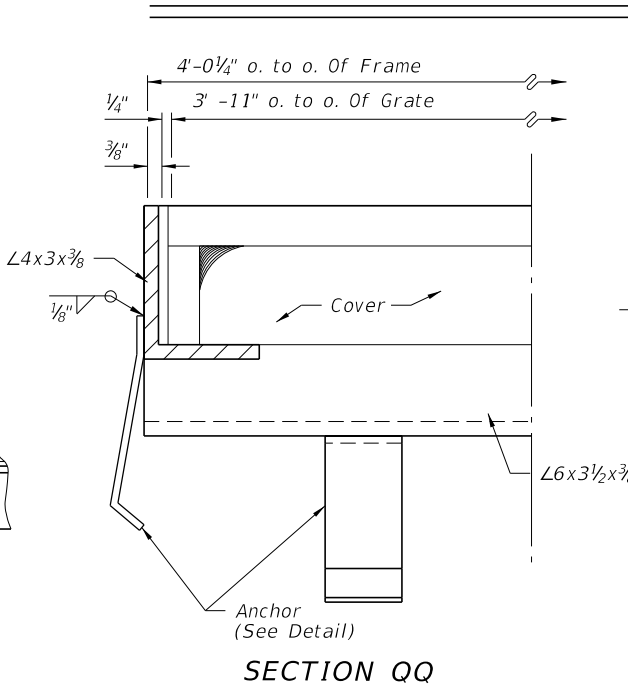
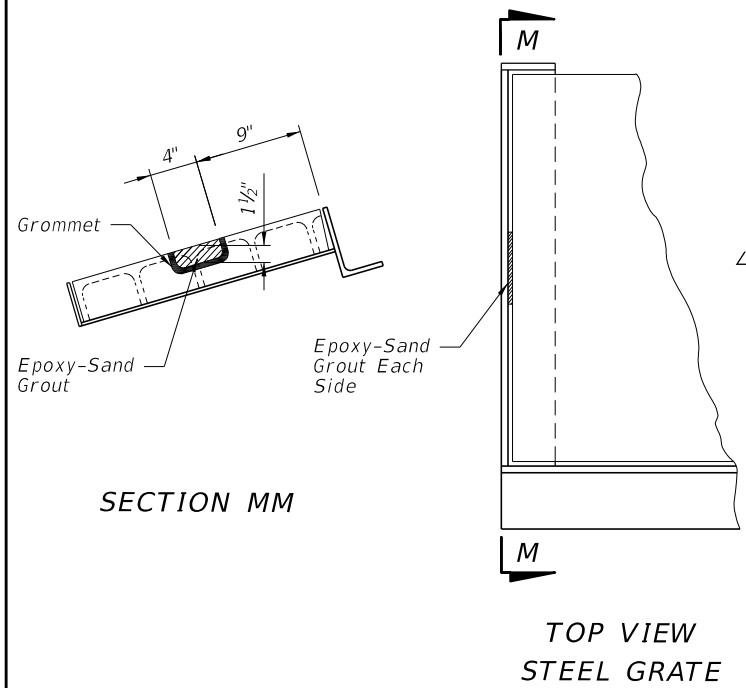

GROUTING DETAILS

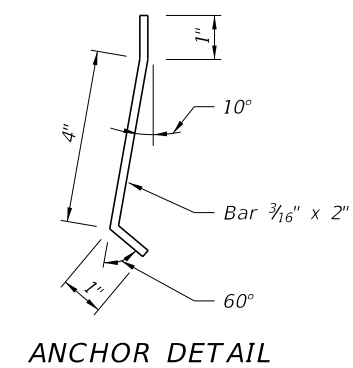
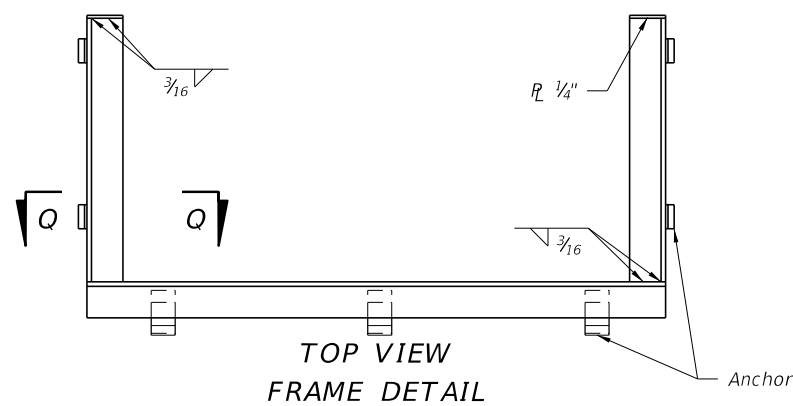

CROSS REFERENCES:
For Location Of Section GG and QQ
See Sheet 1.

10/30/2018 8:43:47 AM

LAST REVISION 11/01/17	DESCRIPTION:		FY 2019-20 STANDARD PLANS	CURB INLET TOPS TYPES 5 AND 6	INDEX 425-021	SHEET 5 of 5

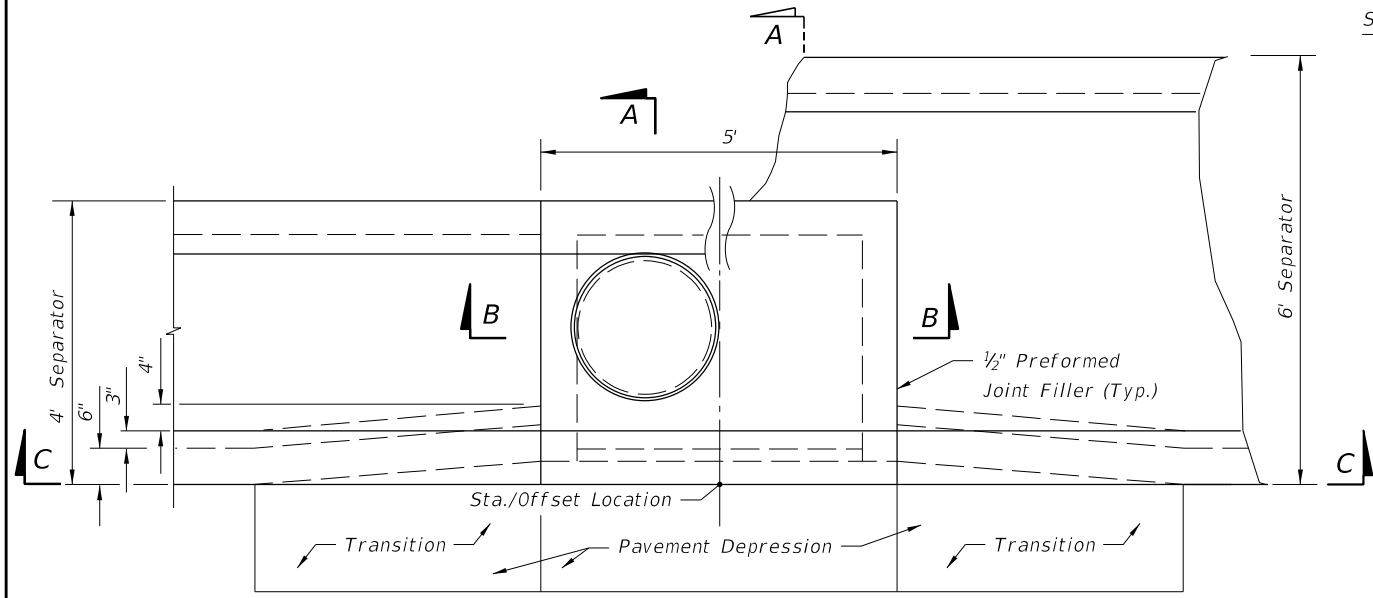

PLAN

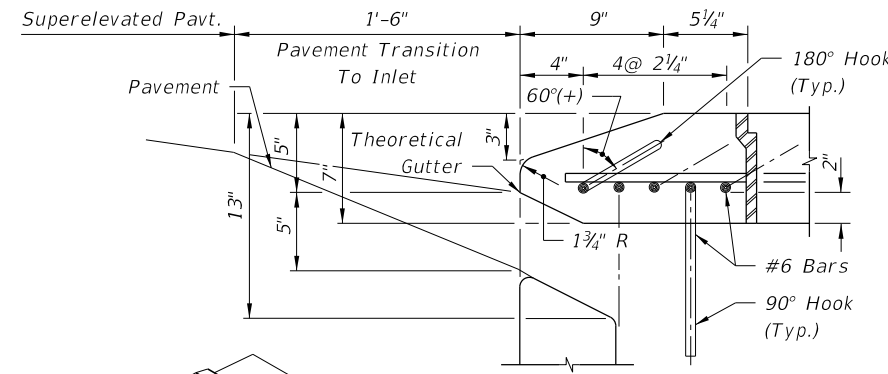

THROAT DETAIL

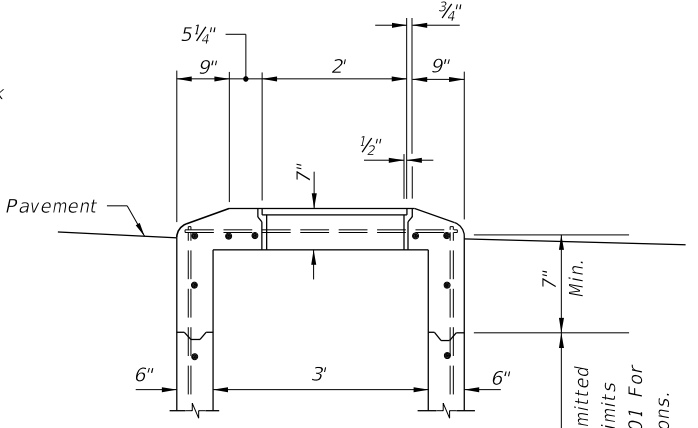

MODIFICATION WHEN USED AS A MANHOLE

#6 Bars ACI Std. Hooks Required Each End of Straight Bars and Right End of Bent Bars: 180° Hooks, Canted 60°(+), on Odd Bars; 90° Hooks, Down, on Even Bars Numbered from Throat Side.

Const. Joints Permitted Between These Limits See Index 425-001 For Minimum Dimensions.

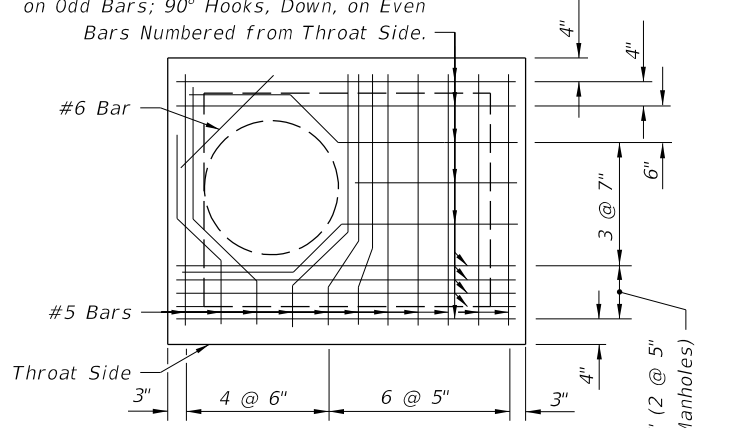

REINFORCING STEEL DIAGRAM TOP SLAB OF INLETS

4 @ 2 1/4\"/>

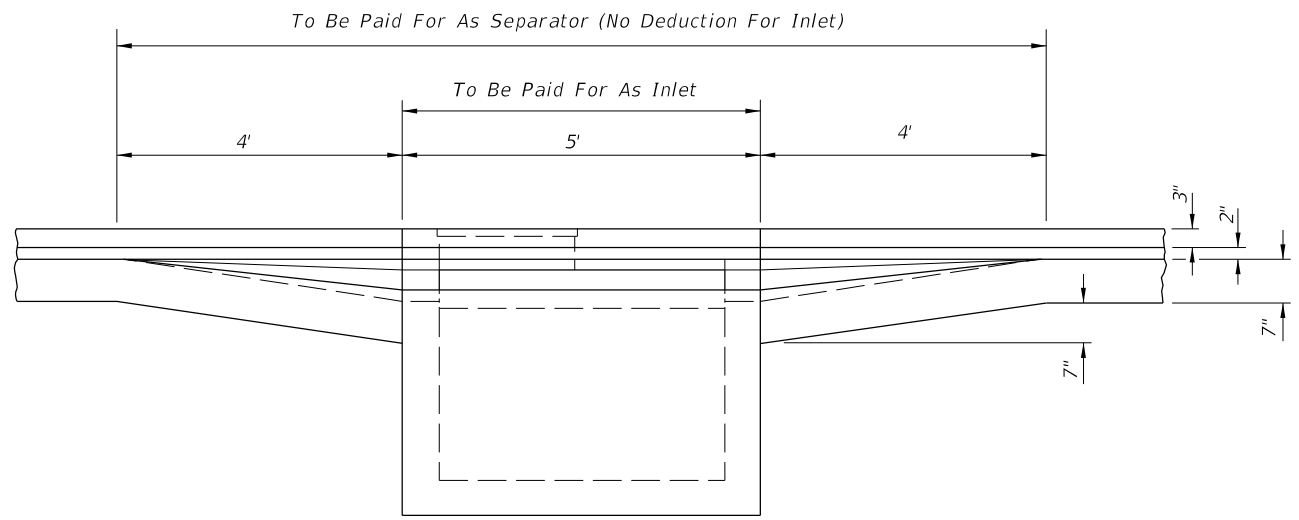

HORIZONTAL WALL REINFORCING SCHEDULE (TABLE 1)

WALL DEPTH	SCHEDULE	AREA (in. ² /ft.)	MAX. SPACING	
			BARS	WWF
0' - 6'	A12	0.20	12"	8"
6' - 10'	A6	0.20	6"	5"
10' - 13'	A4	0.20	4"	3"
10' - 15'	B5.5	0.24	5 1/2"	5"

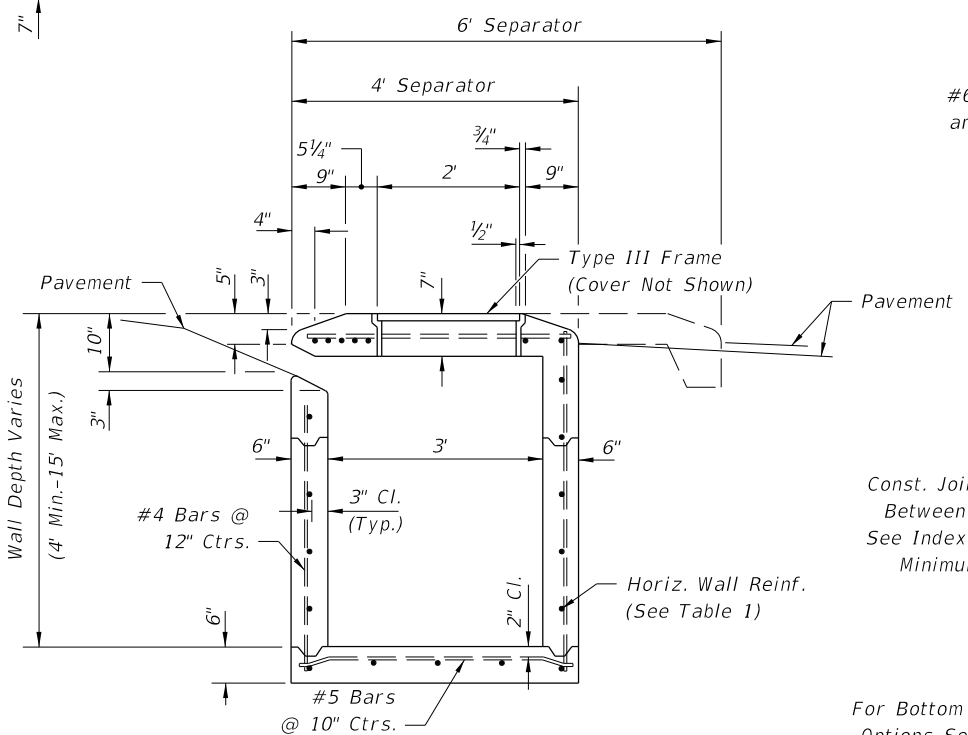

SECTION AA

#6 Bars - See Throat Detail and Reinforcing Diagram for Hook Arrangement

Const. Joints Permitted Between These Limits See Index 425-001 For Minimum Dimensions

For Bottom Slab Rebar Embedment Options See Optional Construction Joints, Index 425-001

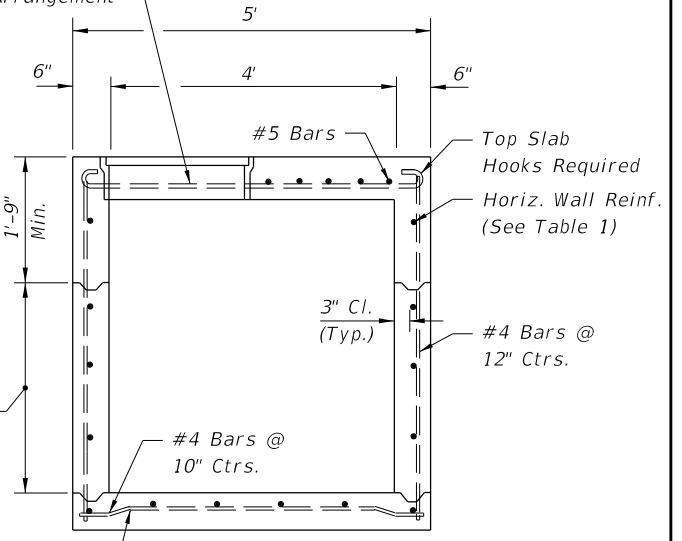

SECTION BB

GENERAL NOTES

1. This inlet is used in Traffic Separators Types I and II; or, in separators constructed with Curbs Types A, B and E and sidewalk paving, which cannot accommodate Inlets Types 1, 2, 3, 4, 5, or 6. Use of this Inlet on through traffic side of the separator is not permitted in medians with Curb Types A and B. Locate inlet outside of pedestrian way.
2. All reinforcing to be Grade 60 bars with 2" min. cover unless otherwise shown. See Index 425-001 for equivalent area of welded wire fabric. Cut or bend bars out of way of pipe when necessary. Bars to clear pipe by 1 1/2"
3. Recommended maximum pipe sizes are 24" longitudinal and 30" transverse. For larger pipe, inlets with Alt. B bottoms, Index 425-010 are recommended.
4. For supplementary details see Index 425-001.
5. All dimensions are for both precast and cast-in-place inlets unless otherwise shown.
6. Inlet to be paid for under the contract unit price for Inlets (Curb) (Type 7), Each.

10/30/2018 8:43:51 AM

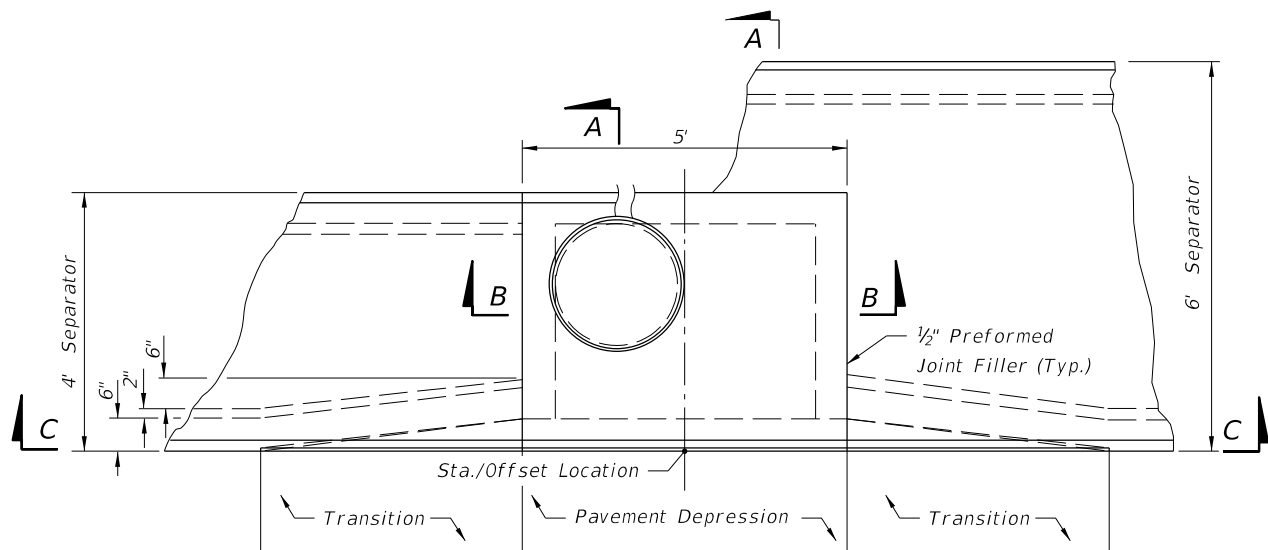

PLAN

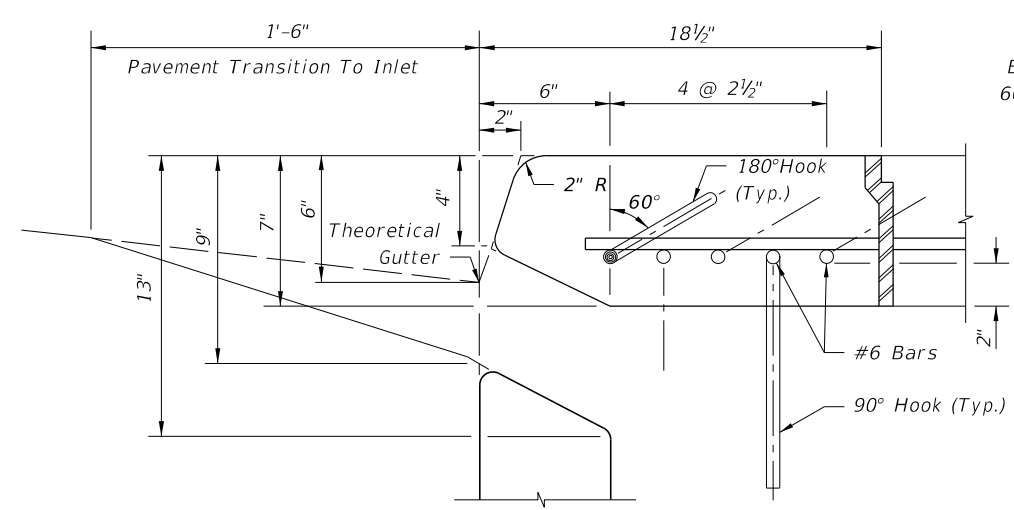

THROAT DETAIL (SECTION AA)

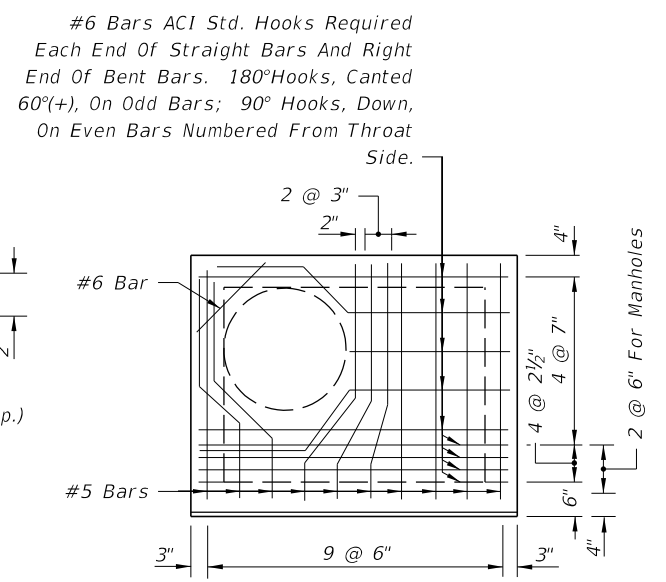

REINFORCING STEEL DIAGRAM TOP SLAB OF INLET

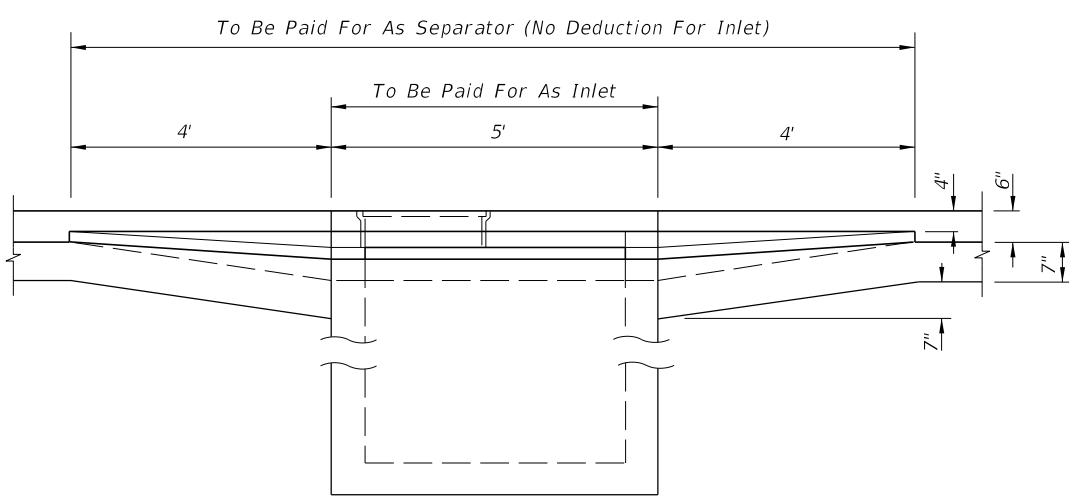

SECTION CC

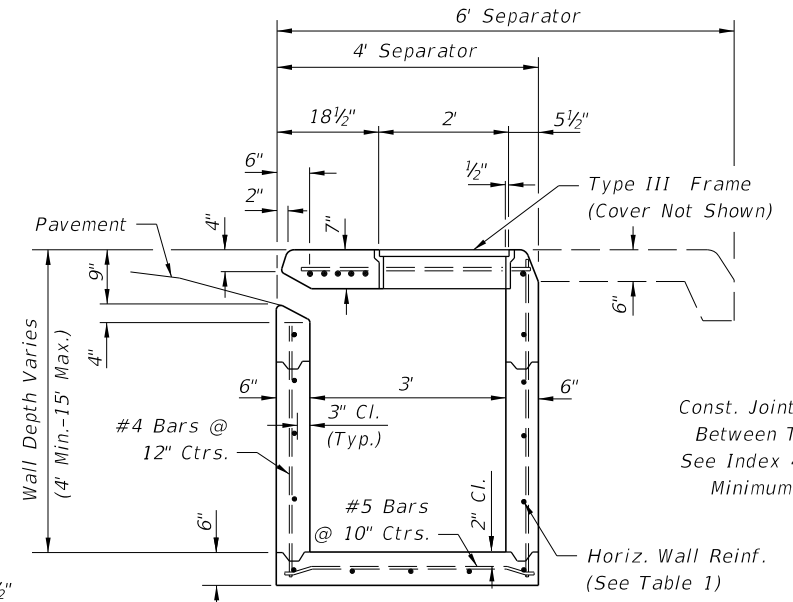

SECTION AA

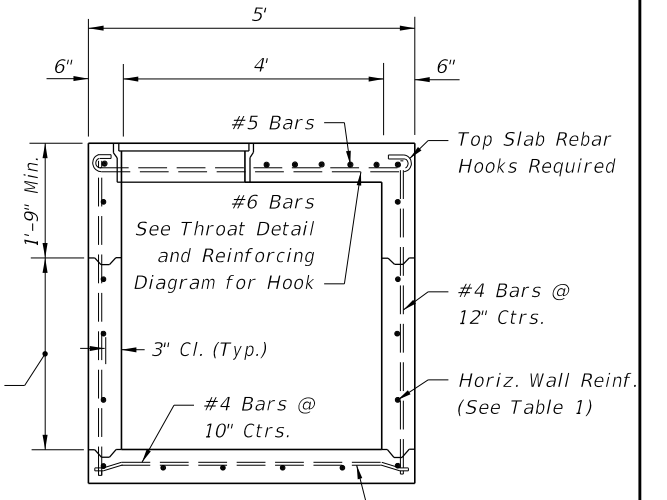

SECTION BB

GENERAL NOTES

1. This inlet is to be used only in Traffic Separators Types IV and V; or, in separators constructed with Curbs Types D and F and sidewalk paving, which cannot accommodate Inlets Types 1, 2, 3, 4, 5 or 6. Use of this inlet on the through traffic side of the separator should be avoided in medians constructed with Curb Type D (Curb inlets Types 9 or 10 are recommended). Locate inlet outside of pedestrian way.
2. All reinforcing to be Grade 60 bars with 2" min. cover unless otherwise shown. See Index 425-001 for equivalent area of welded wire fabric. Cut or bend bars out of way of pipe when necessary. Bars to clear pipe by 1 1/2".
3. Recommended maximum pipe sizes are 24" longitudinal and 30" transverse. For larger pipe, inlets with Alt. B bottoms, Index 425-010 are recommended.
4. For supplemental details and notes see Index 425-001.
5. All dimensions are for both precast and cast-in-place inlets unless otherwise shown.
6. Inlet to be paid for under the contract unit price for Inlets (Curb) (Type 8), Each.

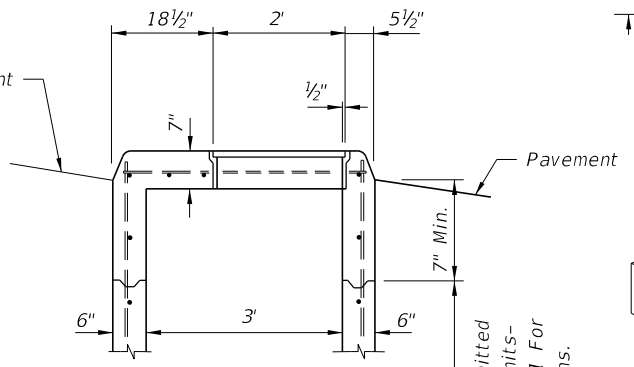

MODIFICATION WHEN USED AS A MANHOLE

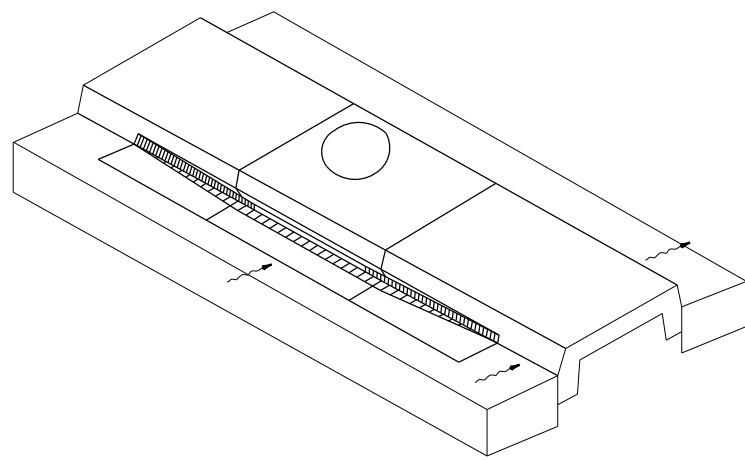

HORIZONTAL WALL REINFORCING SCHEDULE (TABLE 1)

WALL DEPTH	SCHEDULE	AREA (in. ² /ft.)	MAX. SPACING	
			BARS	WWF
0' -6'	A12	0.20	12"	8"
6' -10'	A6	0.20	6"	5"
10'-13'	A4	0.20	4"	3"
10'-15'	B5.5	0.24	5 1/2"	5"

10/30/2018 8:43:54 AM

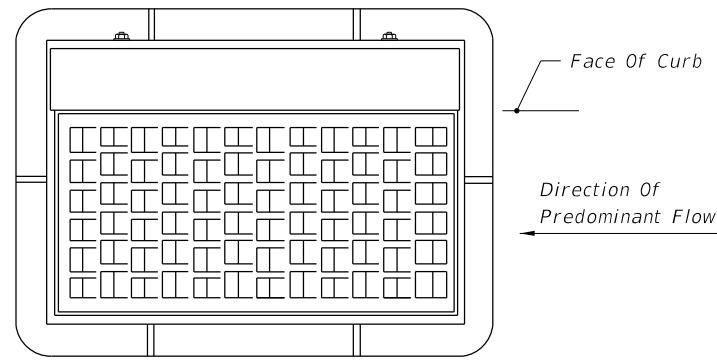

TOP VIEW

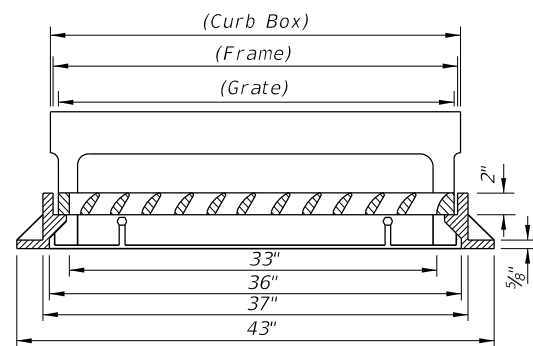

LONGITUDINAL SECTION

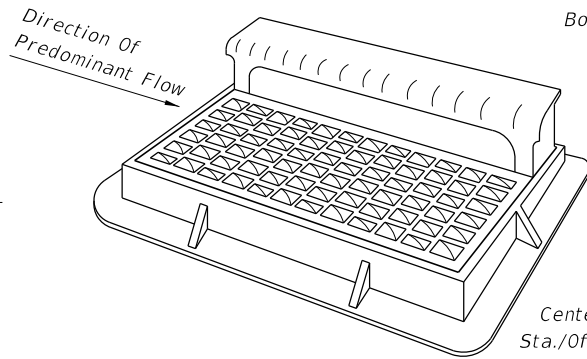

#5 Bars Top #6 Bars Bottom 12" Returns, Each (Min.)

Center of Opening Sta./Offset Location

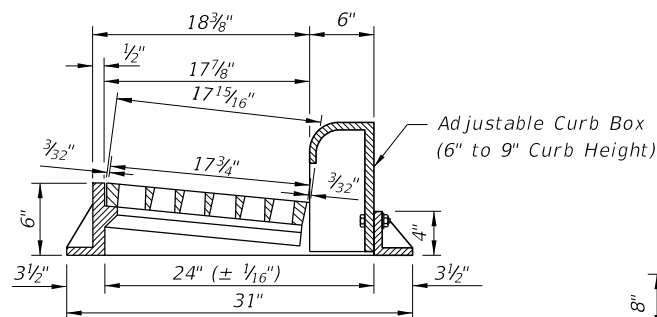

TRANSVERSE SECTION

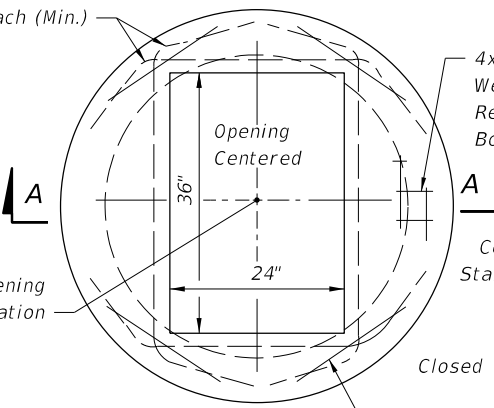

TOP VIEW

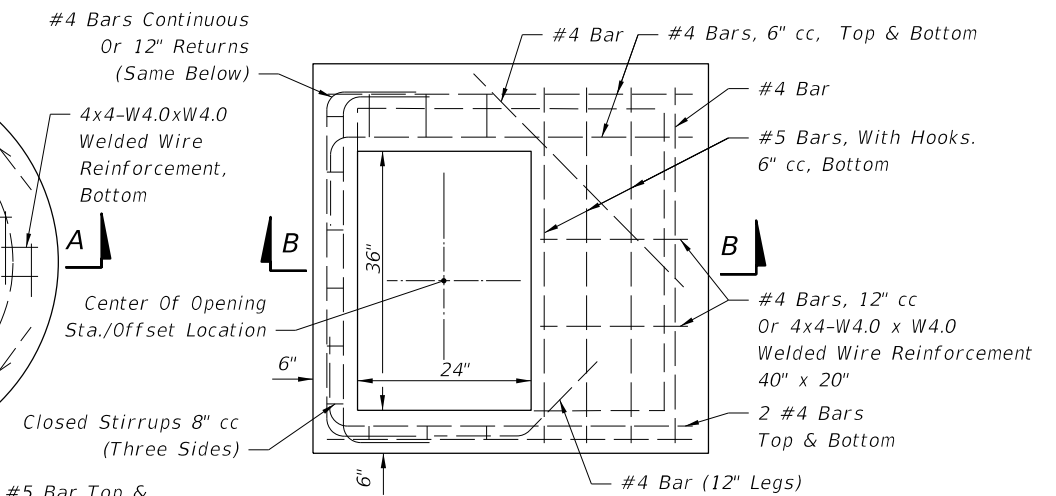

TOP VIEW

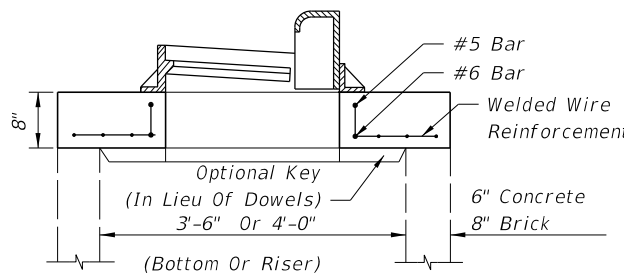

SECTION AA
(SEE NOTE 6 BELOW)

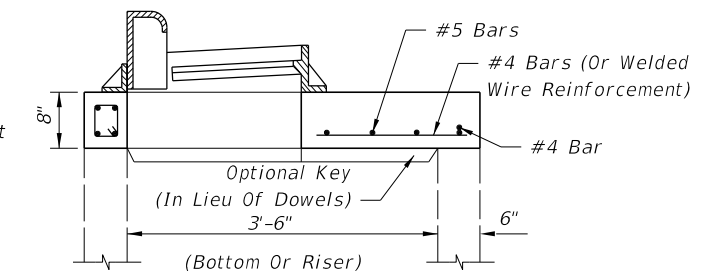

SECTION BB
(SEE NOTE 6 BELOW)

TOP SLABS

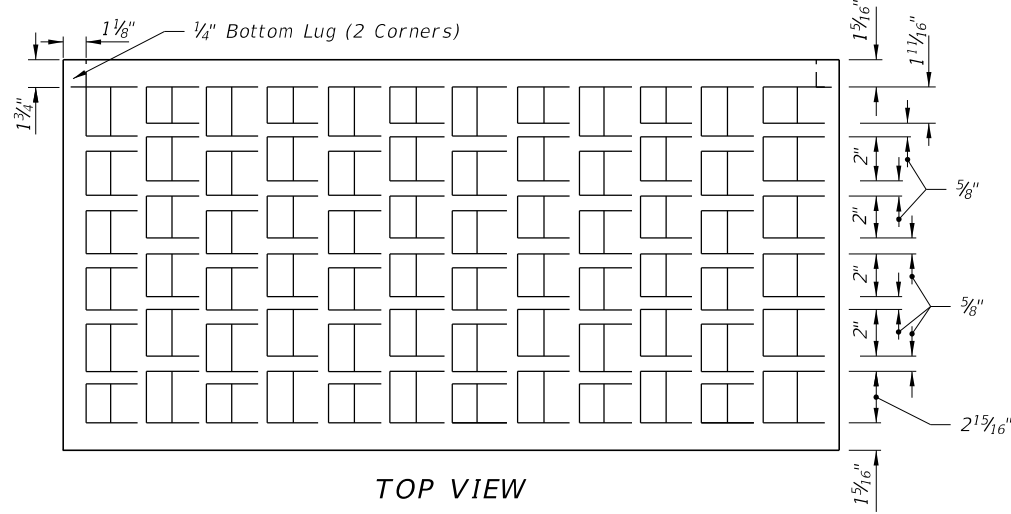

TOP VIEW

Approximate Debris Free Capacity
(0.02 Pavement Cross Slope)

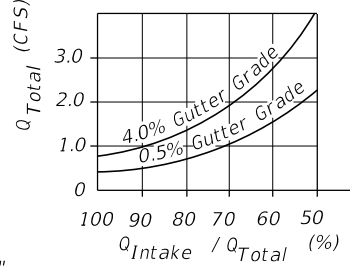

EFFICIENCY CURVE

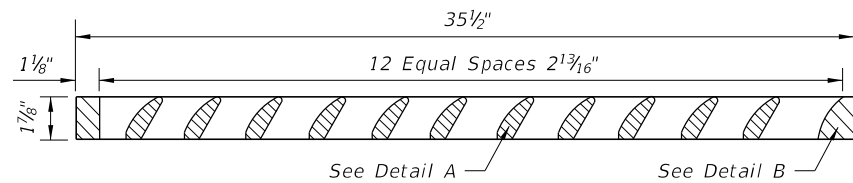

SECTION

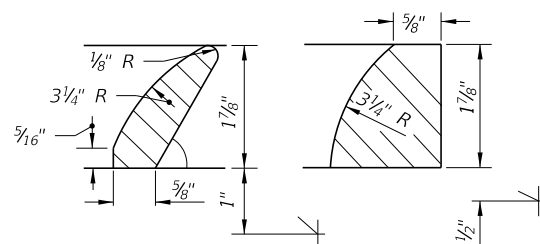

DETAIL A DETAIL B

GRATE DETAIL

GENERAL NOTES

1. This inlet is primarily intended for locations with light to moderate flows where right of way does not permit the use of throated Curb Inlets Types 1 through 6. The typical application is on curb returns to city streets. The inlet grate is suitable for pedestrian and bicycle traffic.
2. This inlet to be located outside of curb ramp area in vertical faced curbs such as Curb and Gutter Type F. Grate shall be oriented with vanes directed toward Predominant flow.
3. For structure bottoms see Index 425-010. For supplemental details see Index 425-001.
4. All steel in slab tops shall have 1 1/4" minimum cover unless otherwise shown. Tops shall be either cast-in-place or precast concrete.
5. For Alternate B applications, top slab openings shall be placed such that 2 edges of inlet frame will be located directly above bottom wall or riser wall.
6. When used on a structure with dimensions larger than those detailed above and risers are not applied, the top slab shall be constructed using Index 425-010 with the slab opening adjusted to 24"x36". The "Special Top Slab" on Index 425-010 is not permitted.
7. Frame may be adjusted with one to six courses of brick.
8. Vaned grates with approximately equal openings will be permitted that satisfy AASHTO HL-93 loading. Grates shall be reversible, right or left.

10/30/2018 8:43:57 AM

LAST REVISION 11/01/17	REVISION	DESCRIPTION:	<p>FY 2019-20 STANDARD PLANS</p>	CURB INLET TOP TYPE 9	INDEX 425-024	SHEET 1 of 1
---------------------------	----------	--------------	--------------------------------------	-----------------------	------------------	-----------------

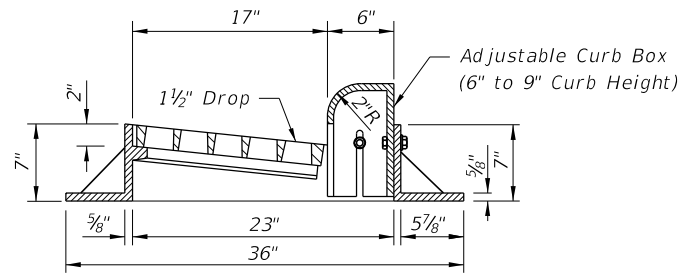
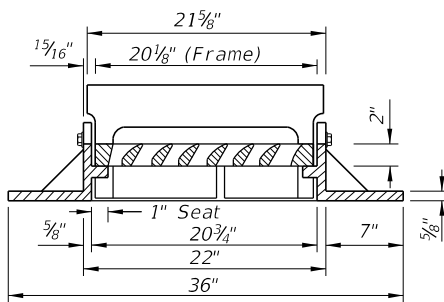
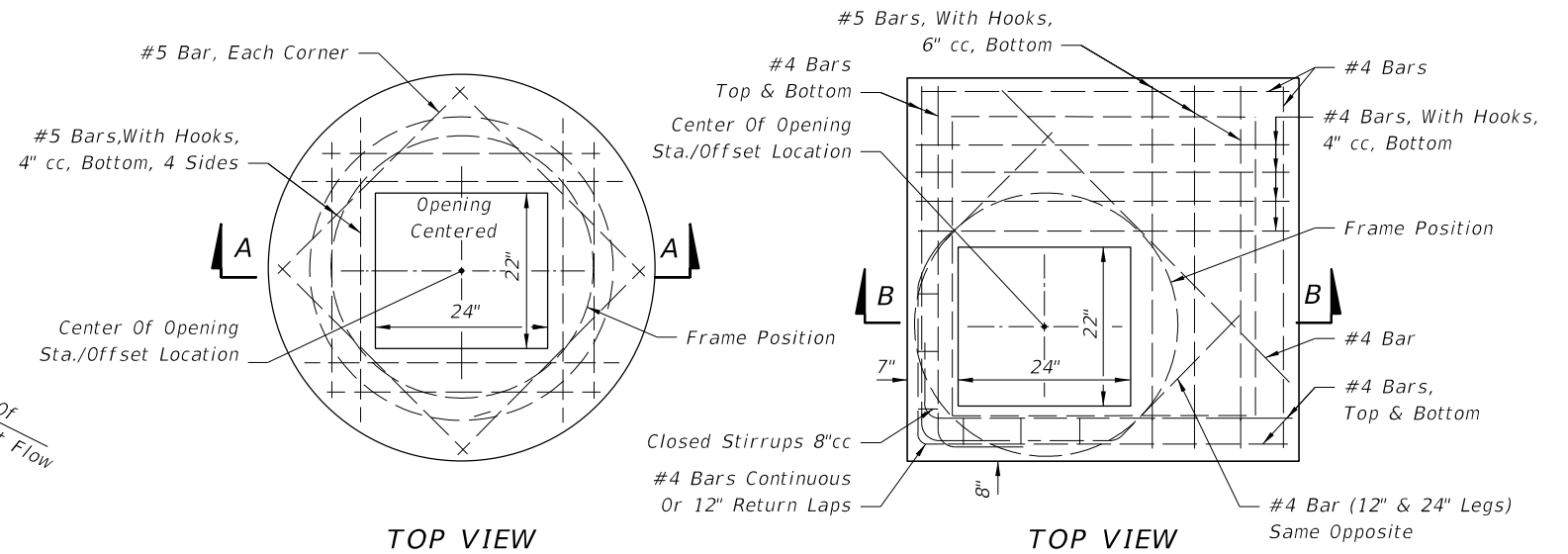
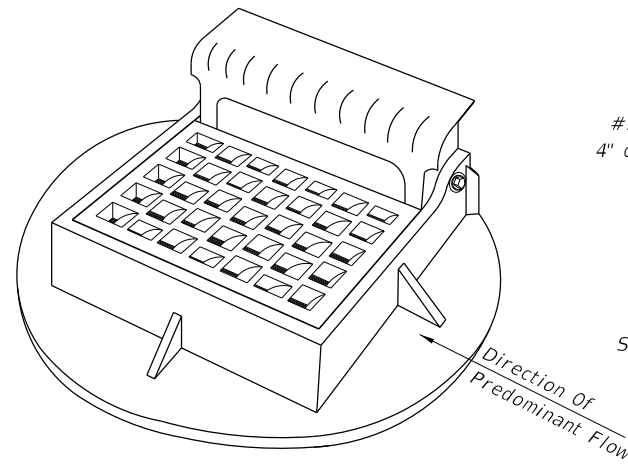
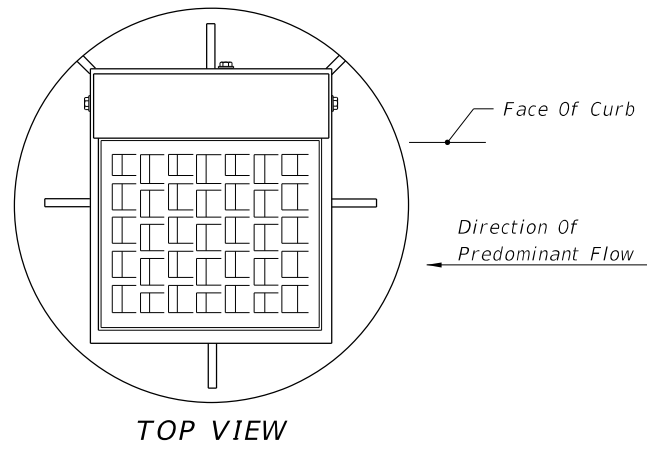

FRAME AND GRATE

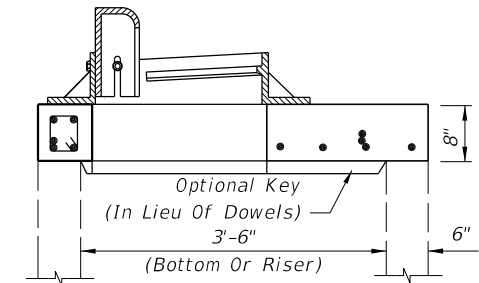
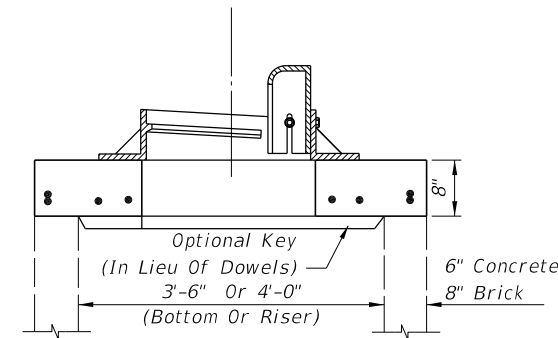

SECTION AA
(SEE NOTE 6 BELOW)

SECTION BB
(SEE NOTE 6 BELOW)

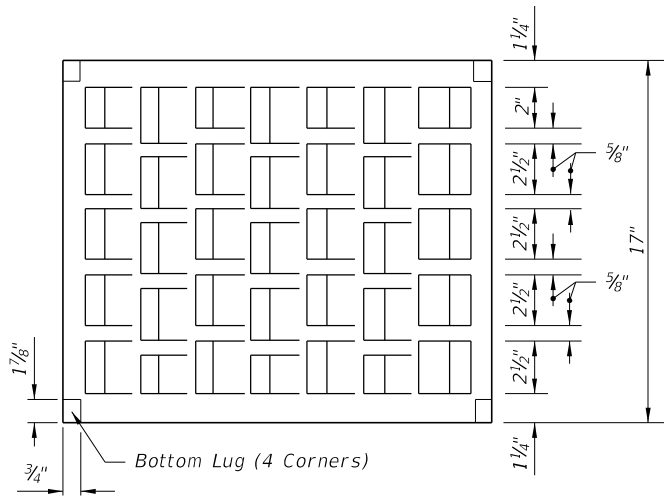

Approximate Debris Free Capacity (0.02 Pavement Cross Slope)

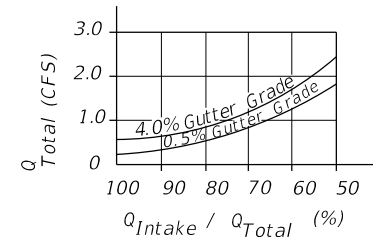

EFFICIENCY CURVE

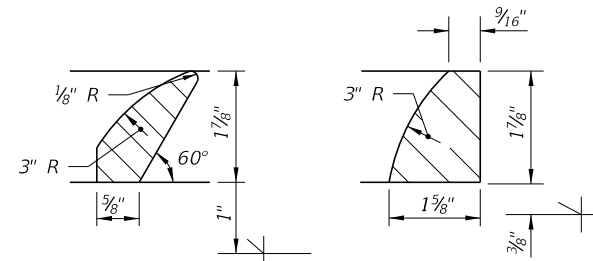
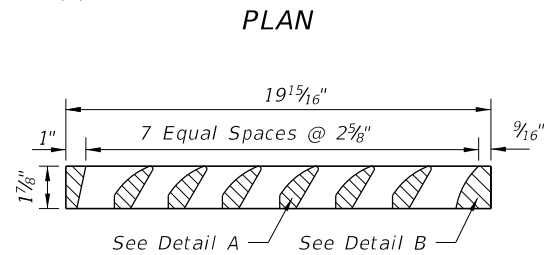

GRATE DETAIL

TOP SLABS

GENERAL NOTES

1. This inlet is primarily intended for locations with light flows where right of way does not permit the use of throated Curb Inlets Types 1 through 6. The typical application is on curb returns to city streets. The inlet grate is suitable for pedestrian and bicycle traffic.
2. This inlet to be located outside of curb ramp area in vertical faced curbs such as Curb and Gutter Type F. Grate shall be oriented with vanes directed toward predominant flow.
3. For structure bottoms see Index 425-010. For supplemental details see Index 425-001.
4. All steel in slab tops shall have 1 1/4" minimum cover unless otherwise shown. Tops shall be either cast-in-place or precast concrete.
5. For Alternate B applications, top slab openings shall be placed such that 2 edges of inlet frame will be located directly above bottom or riser walls.
6. When used on a structure with dimensions larger than those detail above and risers are not applied, the top slab shall be constructed using Index 425-010 with the slab opening adjusted to 22"x24". The "Special Top Slab" on Index 425-010 is not permitted.
7. Frame may be adjusted with one to six courses of brick.
8. Vaned grates with approximately equal openings will be permitted that satisfy AASHTO HL-93 loading. Grates shall be reversible.

10/30/2018 8:44:01 AM

LAST REVISION 11/01/17	DESCRIPTION:		FY 2019-20 STANDARD PLANS	CURB INLET TOP TYPE 10	INDEX	SHEET
					425-025	1 of 1

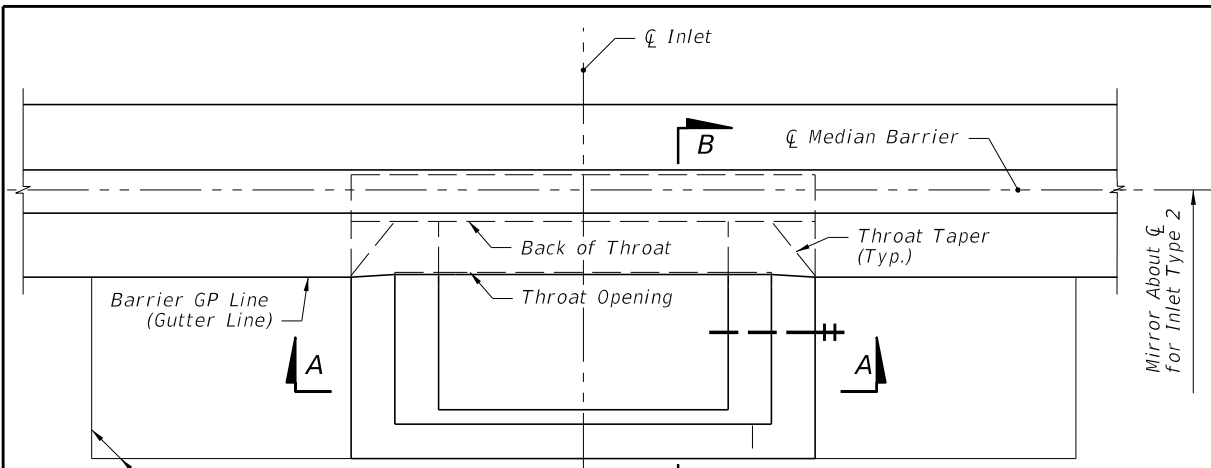

PLAN
(Inlet Type 1 Shown,
Others Similar)

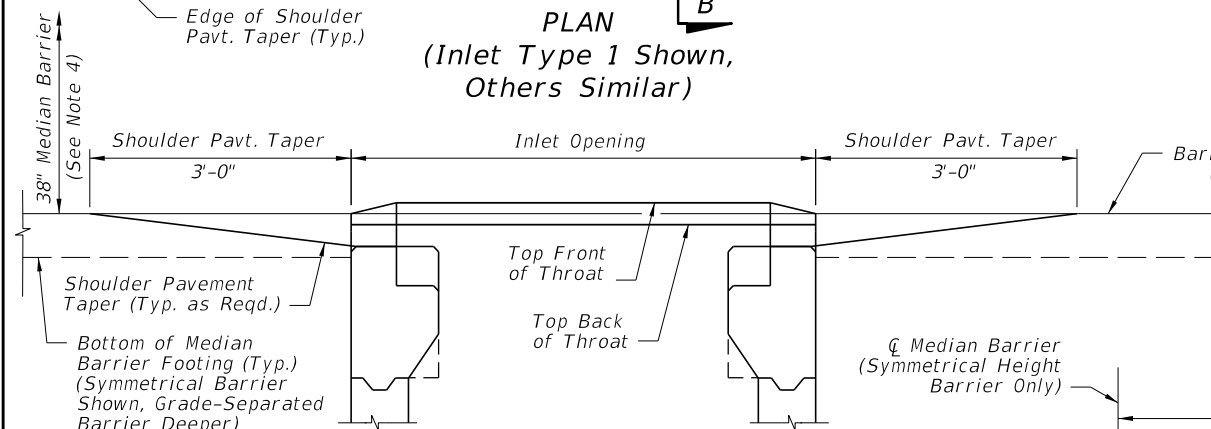

ELEVATION - VIEW C-C
(Grate Not Shown for Clarity)

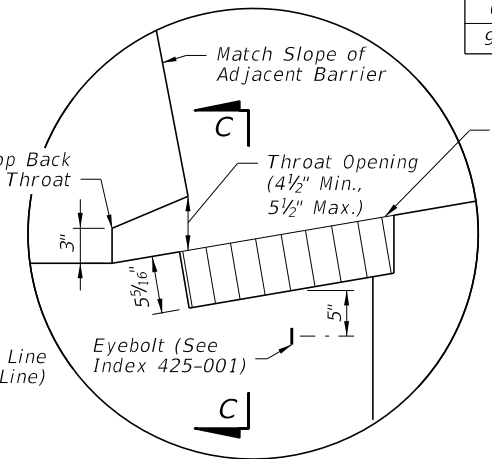

INLET DETAIL

TABLE 1: HORIZONTAL WALL REINFORCING SCHEDULE

WALL DEPTH	SCHEDULE	AREA (in. ² /ft.)	MAX. BARS	SPACING WWF
0'-3'	A12	0.20	12"	8"
3'-6'	A6	0.20	6"	5"
6'-9'	B5.5	0.24	5 1/2"	5"
9'-15'	C6.5	0.37	6 1/2"	6"

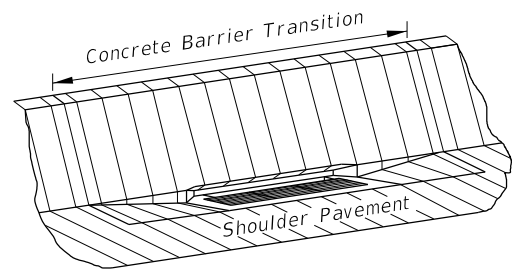

ISOMETRIC VIEW

GENERAL NOTES:

- Where called for in the Plans, use this inlet in conjunction with Median Barrier per Index 521-001.
- Inlet Descriptions:
Type 1: Inlet on one side of Median Barrier
Type 2: Inlet on both sides of Median Barrier
- For grate details, see Index 425-040. The parallel bar grate shall be used unless the reticuline grate is called for in the plans. The reticuline grate shall be specified where bicycle traffic is anticipated. Used in areas of occasional pedestrian traffic. Not suitable for use in pedestrian traffic or bicycle way.
- All exposed edges and corners shall be 3/4" chamfer or tooled to 1/4" radius.
- For standard Median Barrier dimensions and requirements, see Index 521-001.
- Inlet wall reinforcing is Grade 60 #4 bars. The horizontal wall reinforcing must be positioned 3" from the inside face unless otherwise shown. Per Index 425-001, the equivalent area of welded wire fabric is permitted.
- Barrier reinforcing is Grade 60 #4 bars or #5 bars, as required to match the stirrups and longitudinal steel of the adjacent Concrete Barrier per Index 521-001. Barrier reinforcing steel cover may be either 2" or 2 1/2" as needed to match the adjacent barrier reinforcing cover, unless otherwise shown. Match the stirrup spacing of the adjacent barrier. Run Longitudinal steel bars over the full length of the Concrete Barrier Transition and run continuously with the longitudinal steel of the adjacent barriers; use lap splices as required.
- For supplemental details see Index 425-001.
- All dimensions are for both precast and cast-in-place inlets unless otherwise noted.
- Inlets to be paid for under the contract unit price for Inlets (Median Barrier Type_), EA. Concrete Barrier to be paid for under the contract unit price for Concrete Barrier, LF.
- Bond Breaker: One layer of ASTM D6380 Class S, Type III organic felt between inlet and barrier, including footings.

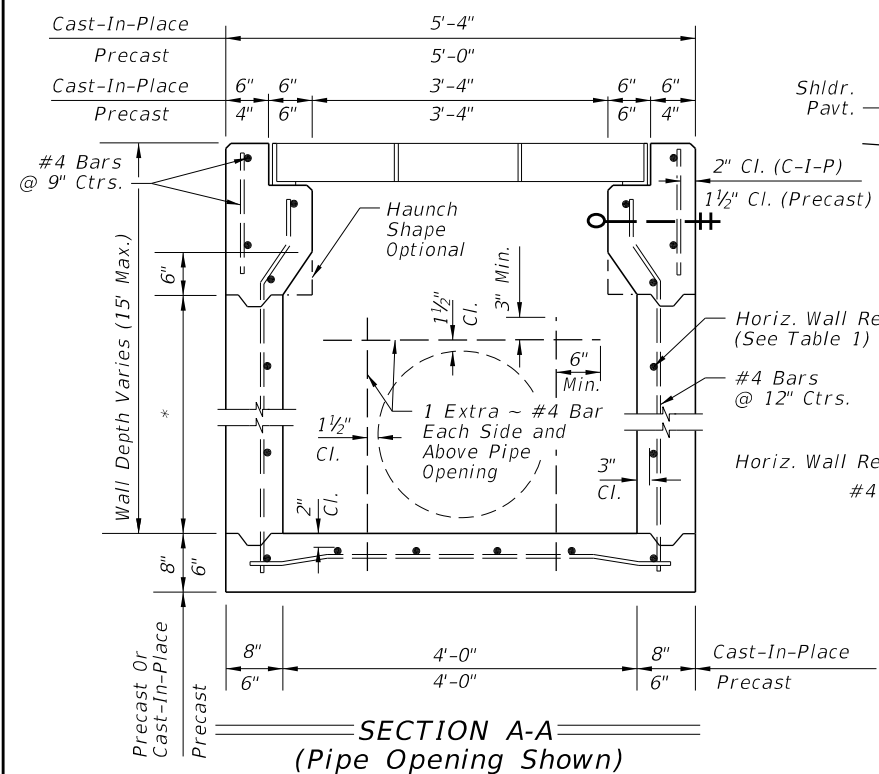

SECTION A-A
(Pipe Opening Shown)

* Const. Joint Permitted Between These Limits See Index 425-001 For Min. Dimensions

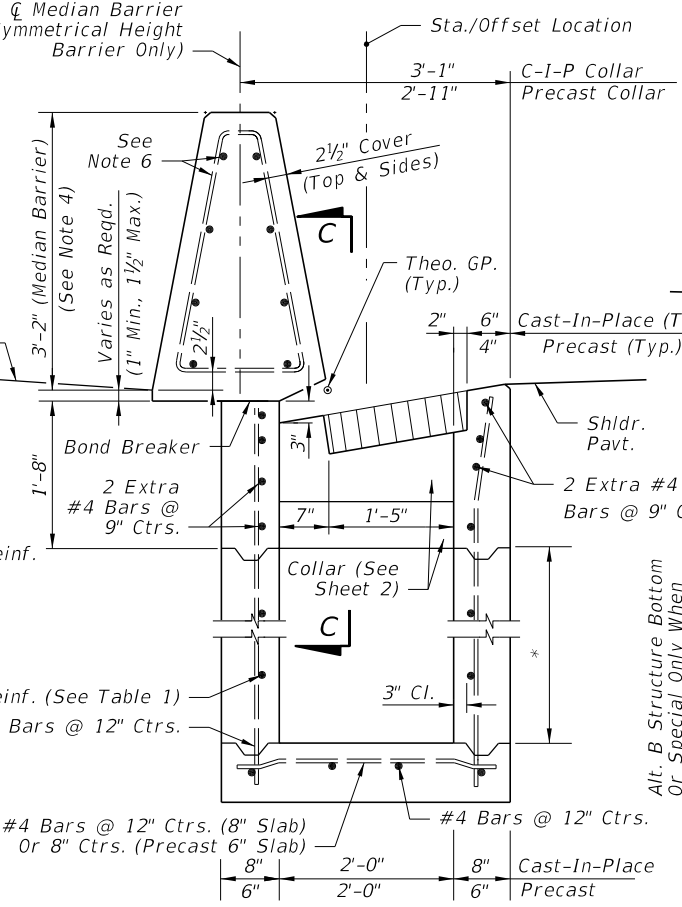

SECTION FOR INLET TYPE 1
(SYMMETRICAL HEIGHT BARRIER ONLY)

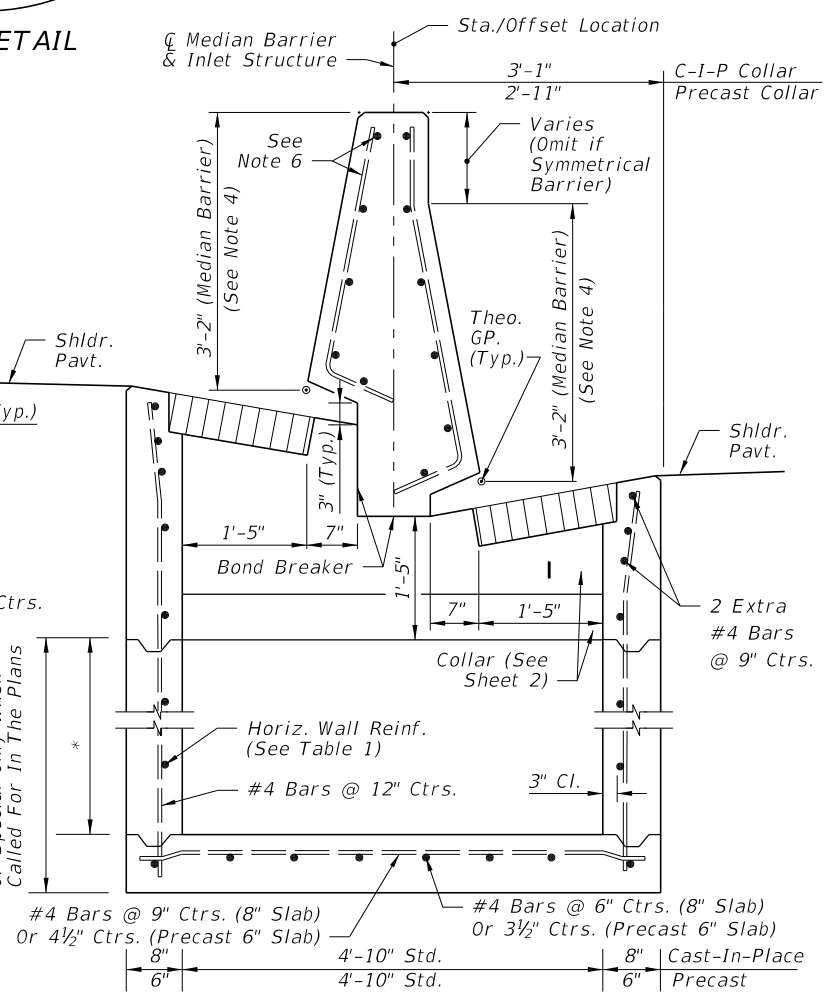

SECTION FOR INLET TYPE 2
(GRADE-SEPARATED BARRIER SHOWN,
SYMMETRICAL HEIGHT BARRIER SIMILAR)

SECTION B-B
(Pipe Opening Not Shown)

11/25/2019 12:40:52 PM

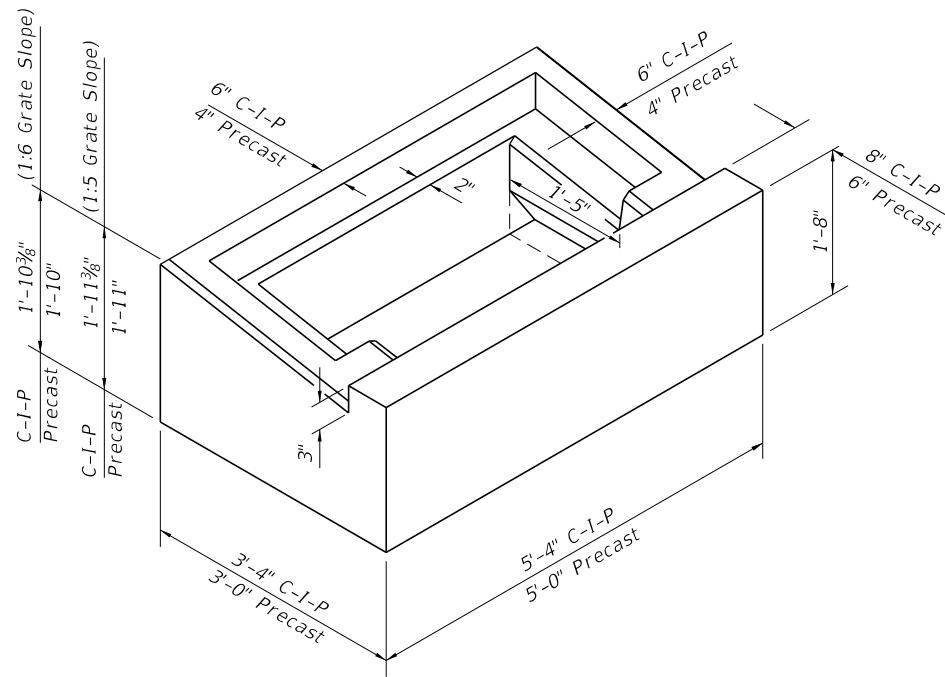

ISOMETRIC VIEW OF INLET COLLAR (TYPE 1)

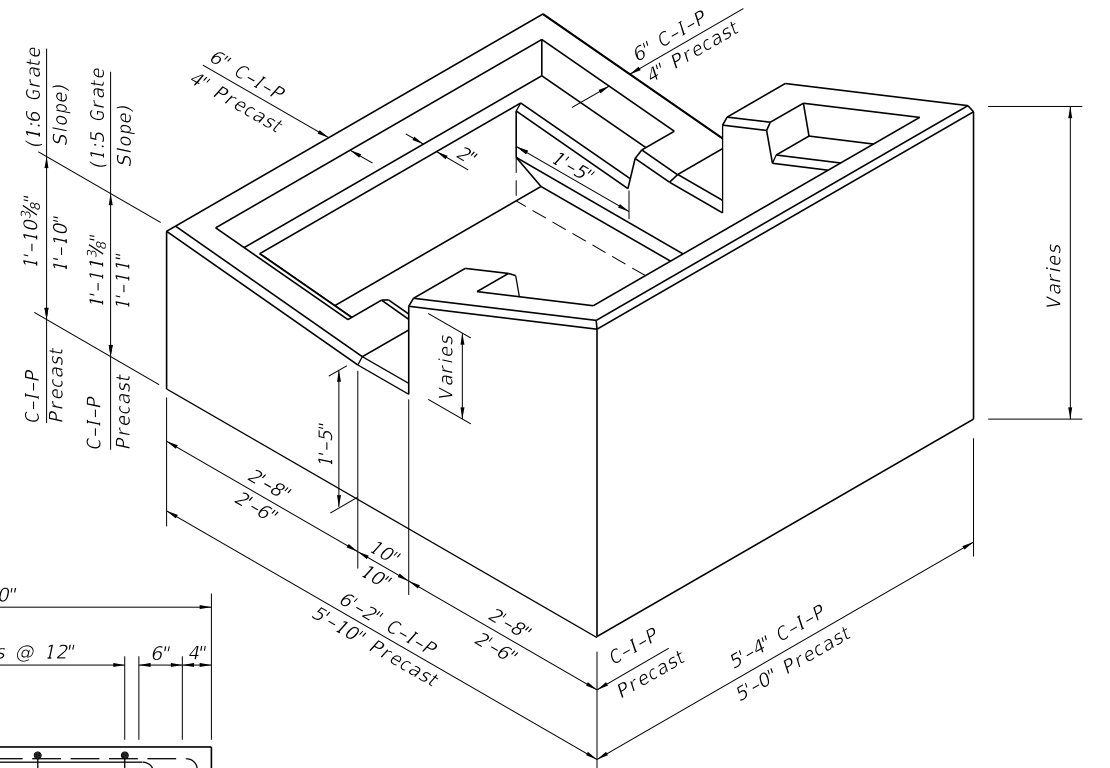

ISOMETRIC VIEW OF INLET COLLAR (TYPE 2)

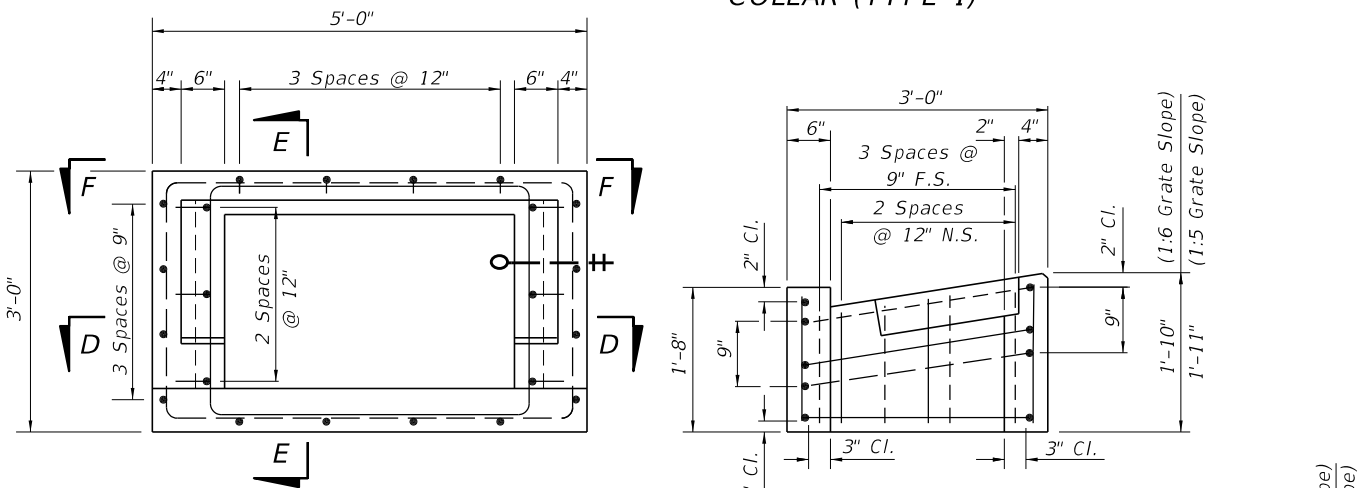

TOP VIEW OF INLET COLLAR WITHOUT GRATE

SECTION EE

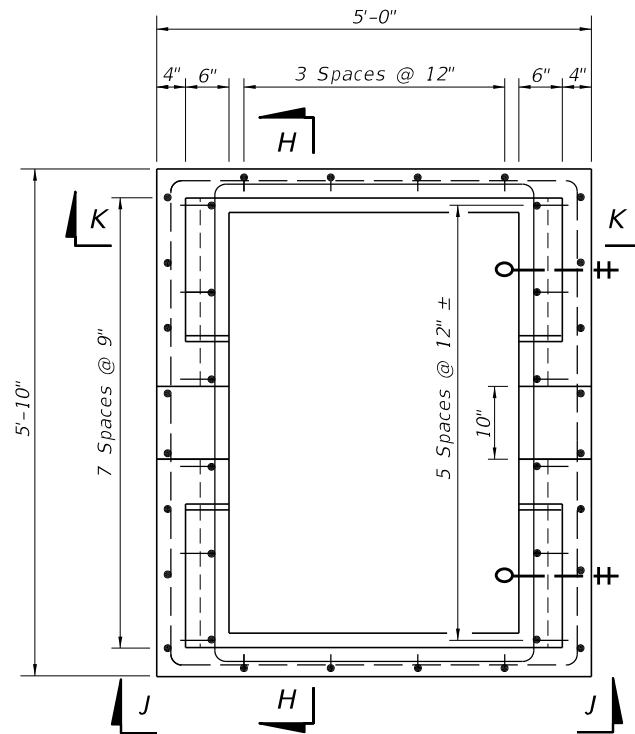

TOP VIEW OF INLET COLLAR WITHOUT GRATE

SECTION HH

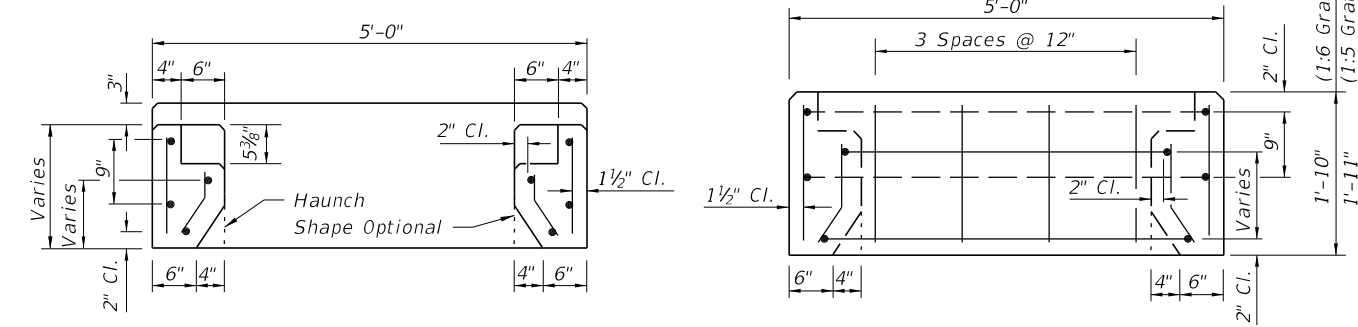

SECTION DD

VIEW FF

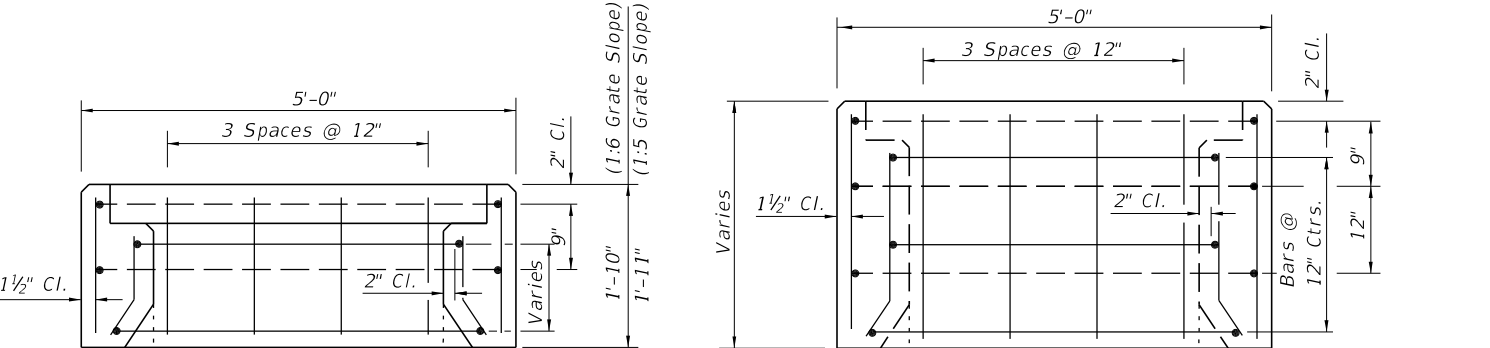

VIEW KK

VIEW JJ

PRECAST COLLAR REINFORCING DETAILS (TYPE 1)
(C-I-P COLLAR REINFORCING DETAILS SIMILAR)

PRECAST COLLAR REINFORCING DETAILS (TYPE 2)
(C-I-P COLLAR REINFORCING DETAILS SIMILAR)

10/30/2018 8:44:09 AM

LAST REVISION 11/01/17	DESCRIPTION:
---------------------------	--------------

**FY 2019-20
STANDARD PLANS**

MEDIAN BARRIER INLETS TYPES 1 AND 2

INDEX 425-030	SHEET 2 of 2
------------------	-----------------

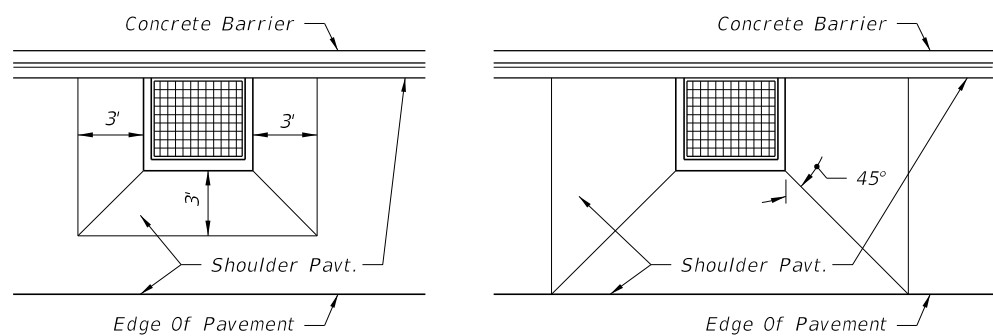

LOW SIDE SUPERELEVATION PAVEMENT WARP FOR SHOULDERS IN SUPERELEVATION
HIGH SIDE TRANSITION PAVEMENT WARP FOR SHOULDERS IN SUPERELEVATION

Joint And Bond Breaker:
Cast-In-Place Inlets:
One layer ASTM D6380 Class S, Type III Organic Felt bond breaker between inlet and barrier, including footings.
Precast Inlets:
Joint width 1" max. Seal with backer rod and Department-approved pavement joint sealant. See Section BB For Other Barrier Shape.

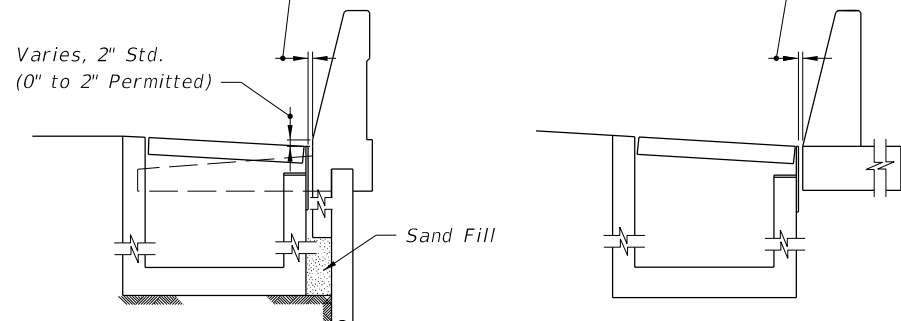

BARRIER - JUNCTION SLAB AND WALL COPING

SHOULDER BARRIER - FOOTING

INLET SECTION AT BARRIERS

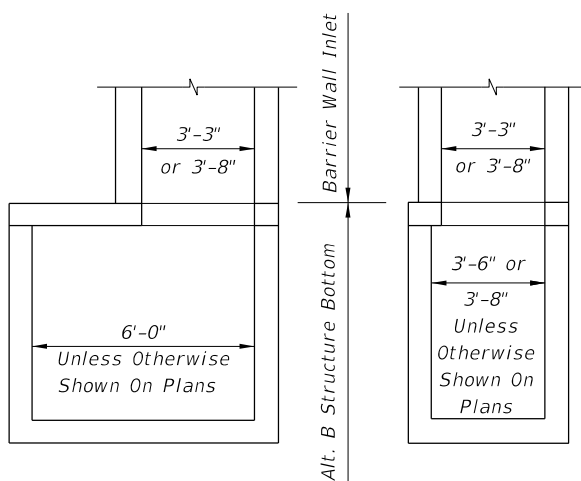

Note: Alt. B Structure Bottom Only. See Index 425-010

INLET WITH STRUCTURE BOTTOM

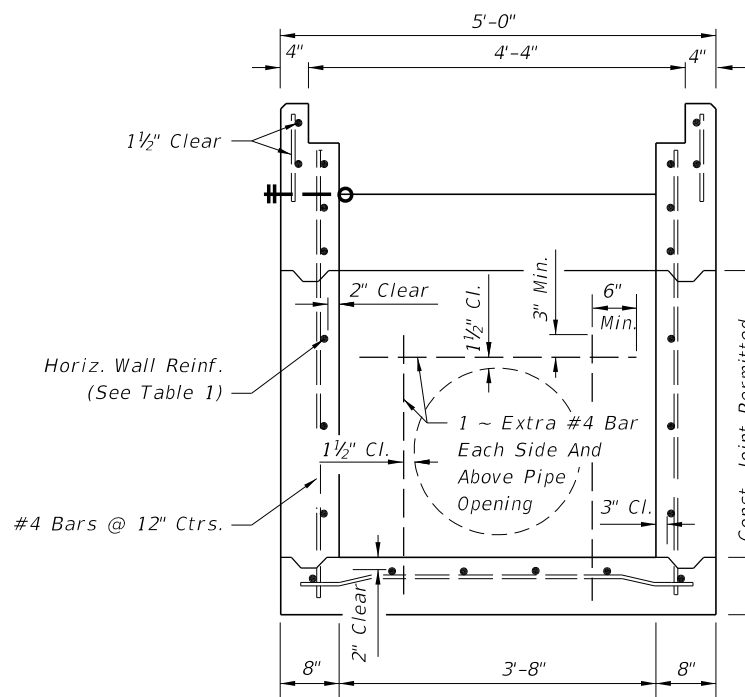

SECTION A-A (WITHOUT GRATE)
(Pipe Opening Shown)

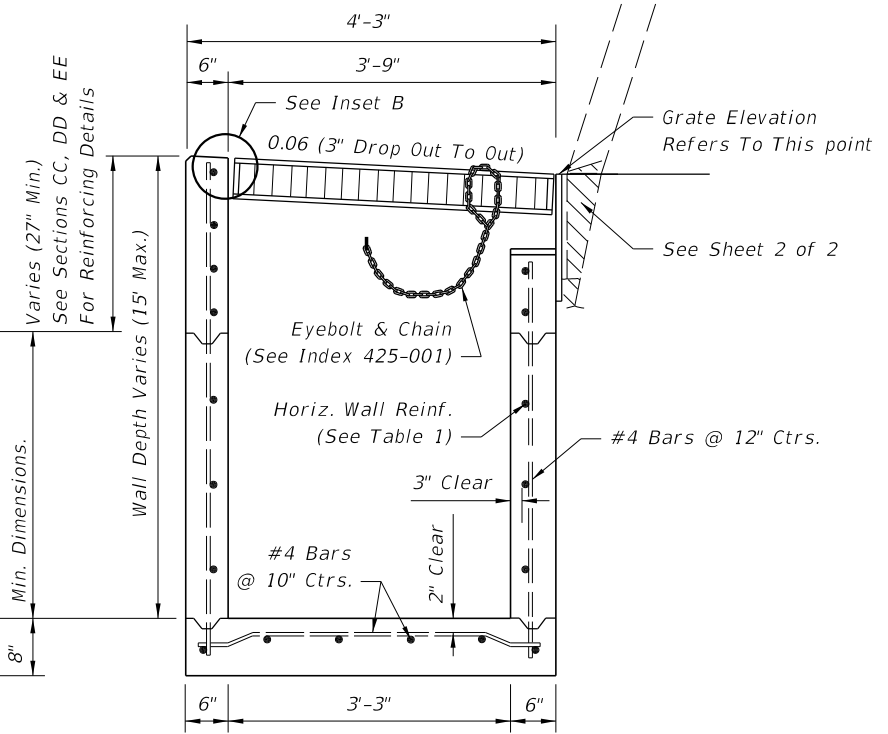

SECTION B-B
(Pipe Opening Not Shown)

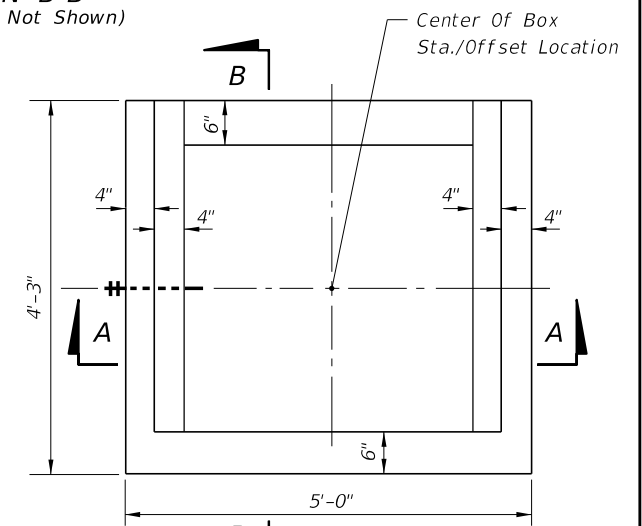

TOP VIEW (WITHOUT GRATE)

GENERAL NOTES:

- Where called for in the Plans, use this inlet in conjunction with Shoulder Barrier per Index 521-001 or a Wall Coping with Barrier and Junction Slab per Index 521-610. Use of the inlet adjacent to other Concrete Barrier or Traffic Railing types requires approval of the Drainage Engineer. The inlet is suitable for bicycle and occasional pedestrian traffic, with roller bar installation (see INSET B), but should not be placed in a designated pedestrian travel way.
- Inlets located in embankments constructed with earth anchored retaining wall shall be designed with minimum depths to reduce adverse impact on the anchorage system. Runs of pipe parallel to and near anchored wall shall be avoided wherever practical. Special coordination must be exercised during the design and construction of storm water systems within anchored wall systems.
- Inlet bottoms and/or tops may be either precast or cast-in-place. Whether cast as a single unit or as multiple segments, and whether precast or cast-in-place, the upper 2'-3" of the inlet shall be reinforced in accordance with sections CC, DD and EE.
- All exposed edges and corners shall be 3/4" chamfer or tooled to 1/4" radius.
- When Alternate G grate is specified in the plans, the grate is to be hot-dip galvanized after fabrication. Field installation of the filler bar called for in Inset B will not be permitted, thereby requiring tolerance adjustment during fabrication and/or casting, or, matching grate to structure prior to galvanizing.
- All reinforcing is Grade 60 bars. See Index 425-001 for equivalent area of welded wire fabric.
- All dimensions are for both precast and cast-in-place inlets unless otherwise noted.
- For supplemental details see Indexes 425-001 and 425-010.
- Inlets to be paid for under the contract unit for Inlets (Concrete Barrier), Ea.

TABLE 1: HORIZONTAL WALL REINFORCING SCHEDULE

WALL DEPTH	SCHEDULE	AREA (in. ² /ft.)	MAX. SPACING	
			BARS	WWF
0'-5'	A12	0.20	12"	8"
5'-10'	A6	0.20	6"	5"
10'-15'	A4	0.20	4"	3"
10'-15'	B5.5	0.24	5 1/2"	5"

10/30/2018 8:44:13 AM

LAST REVISION 12/07/17	DESCRIPTION:
---------------------------	--------------

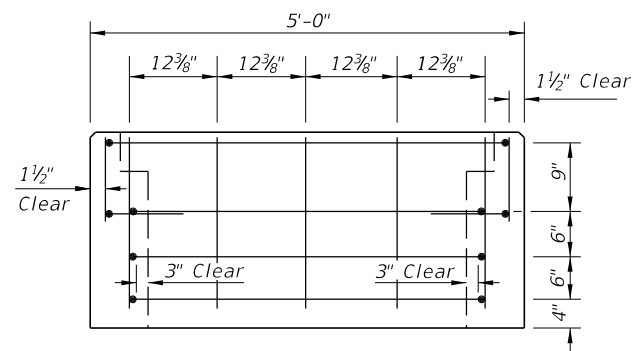

SECTION C-C

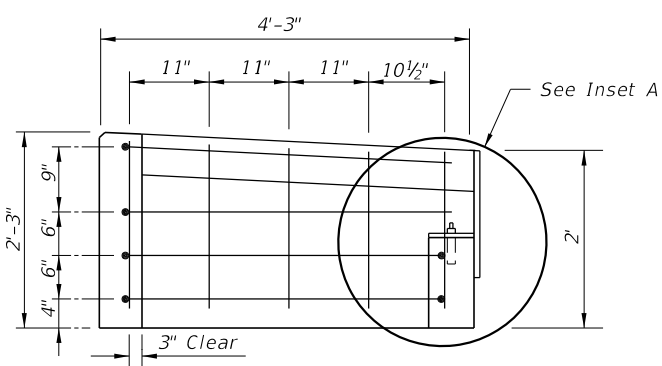

SECTION D-D

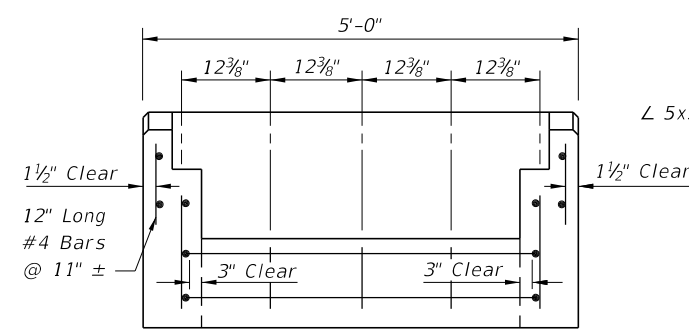

SECTION E-E

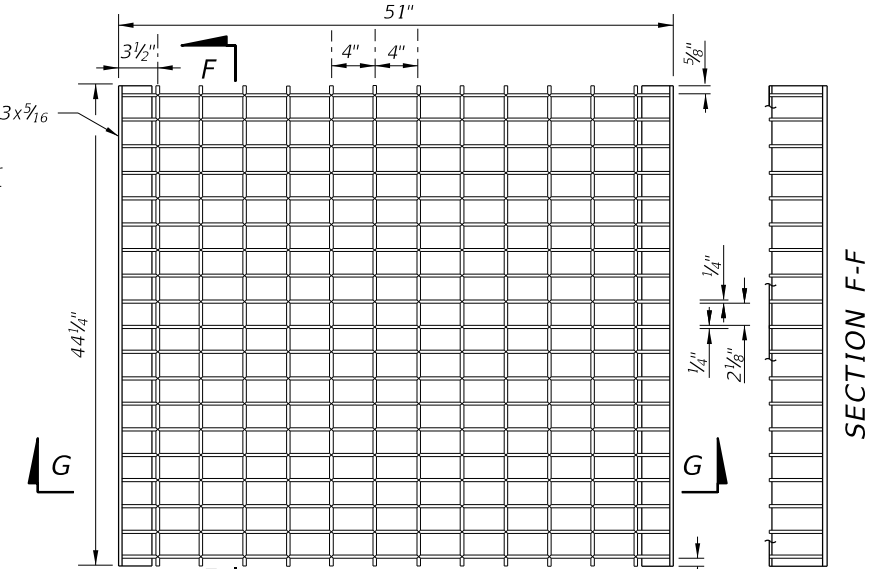

Main Bars: 5"x1/4"
Cross Bars: Either 3/8"Ø Electroforged or 1/2"Ø Welded
TOP VIEW

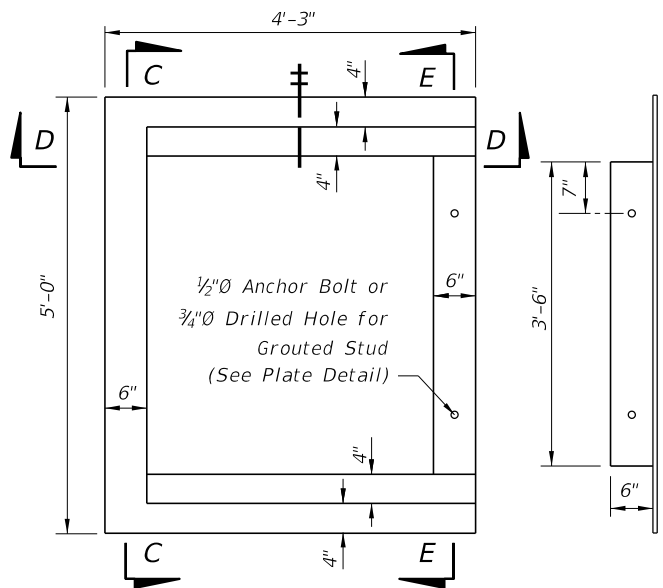

TOP VIEW OF INLET WITHOUT GRATE

TOP VIEW OF METAL PLATE

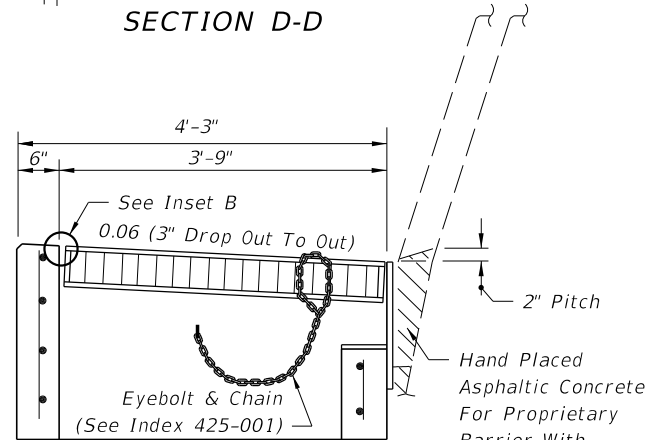

TRANSVERSE SECTION WITH GRATE & PLATE

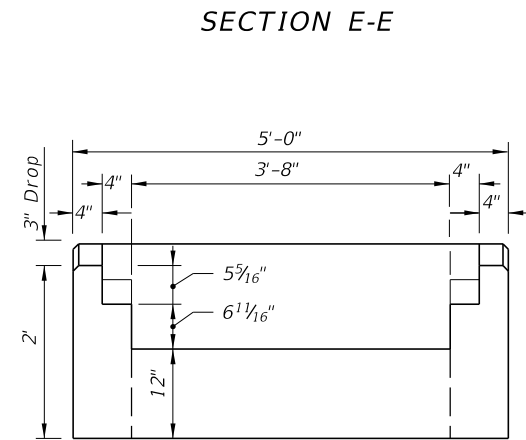

BACK VIEW WITHOUT BACK PLATE

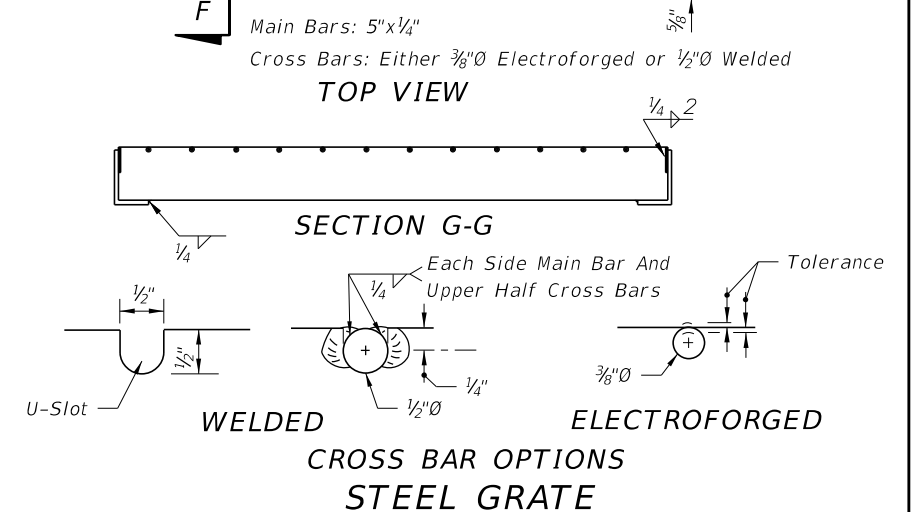

WELDED
ELECTROFORGED
CROSS BAR OPTIONS
STEEL GRATE

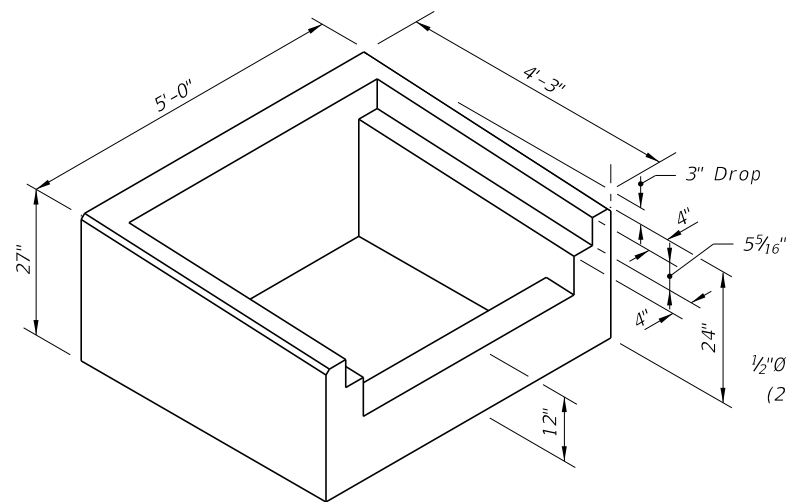

PICTORIAL VIEW OF INLET COLLAR

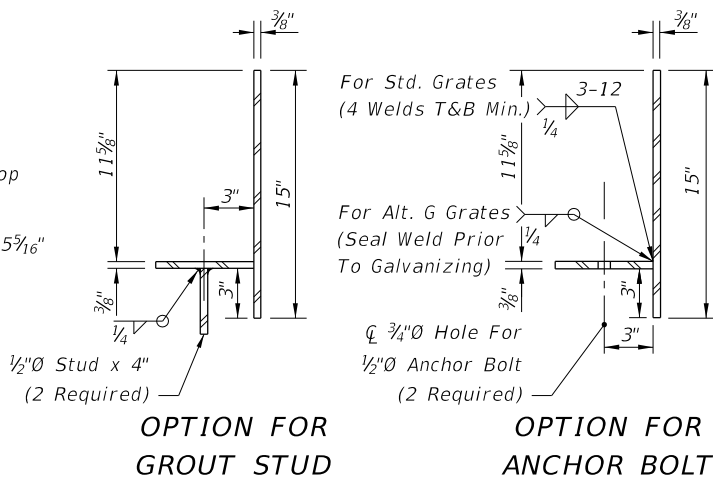

TRANSVERSE SECTIONS THRU BACKWALL PLATE

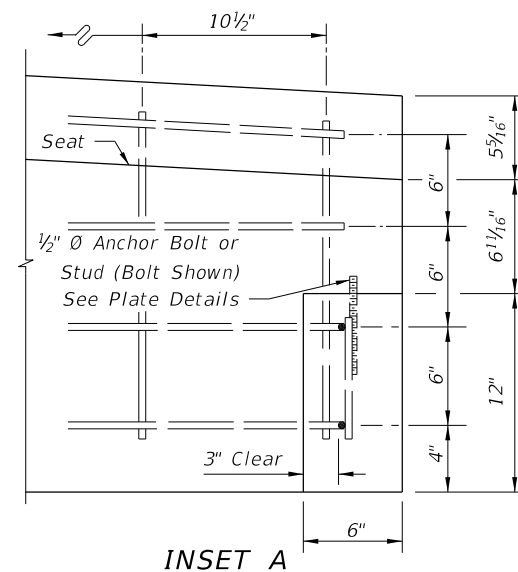

INSET A

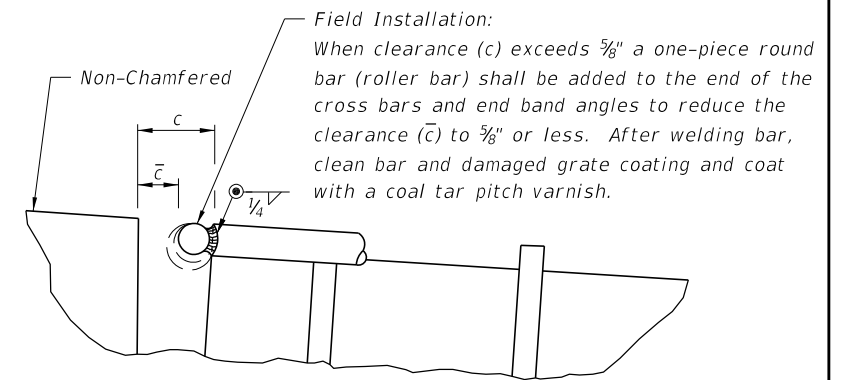

INSET B
(See Sheet 1,
General Note 1)

NOTES

- All reinforcing steel bars shown are #4 bars.
- Anchor bolts shall be either ASTM A307 hex head bolts cast-in-place, or ASTM A36 or F1554 (Grade 36) galvanized fully threaded rod, adhesive bonded anchors installed in accordance with Specification Section 416. Bolts or rods shall be 6" long (4" min. embedment) with one heavy hex head nut (ASTM 194 or A563) and one flat washer (ASTM F436) each. All anchor bolts, nuts and washers shall be hot-dip galvanized.

10/30/2018 8:44:17 AM

LAST REVISION 11/01/17	DESCRIPTION:
---------------------------	--------------



FY 2019-20
STANDARD PLANS

SHOULDER BARRIER INLET

INDEX
425-031

SHEET
2 of 2

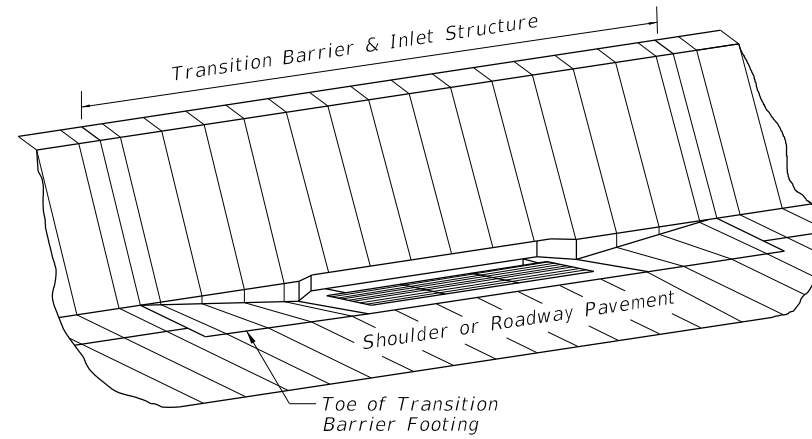
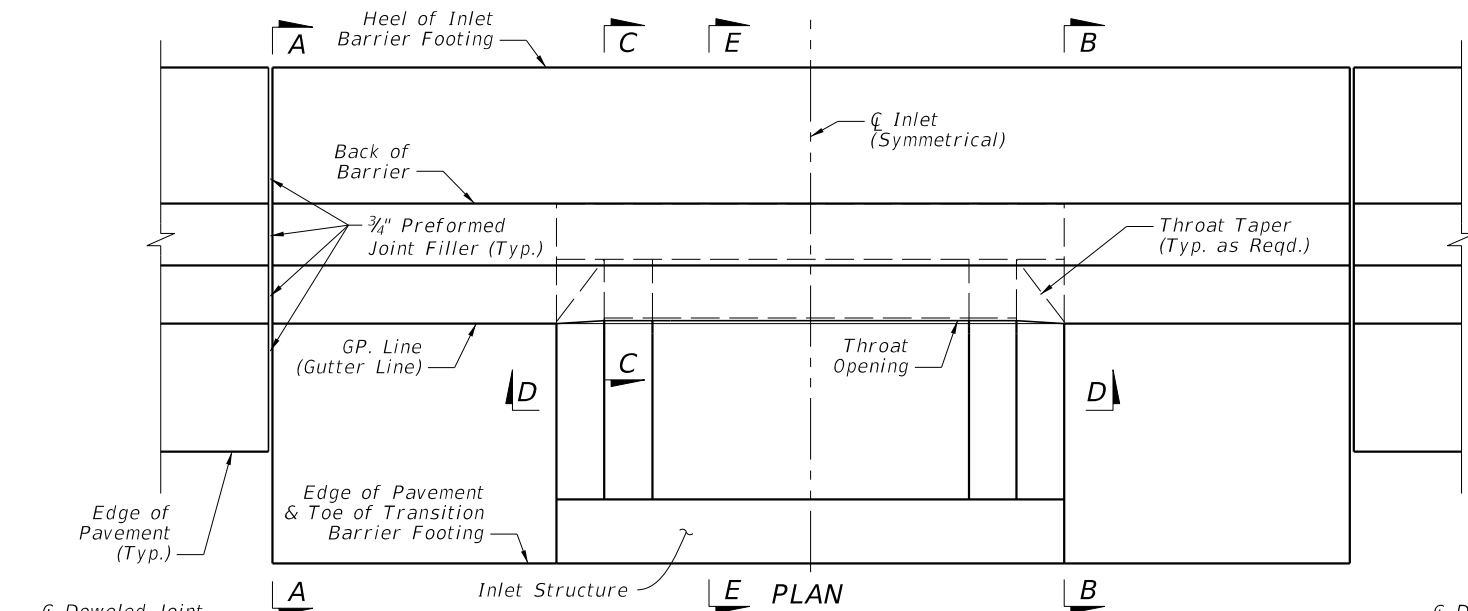

ISOMETRIC VIEW

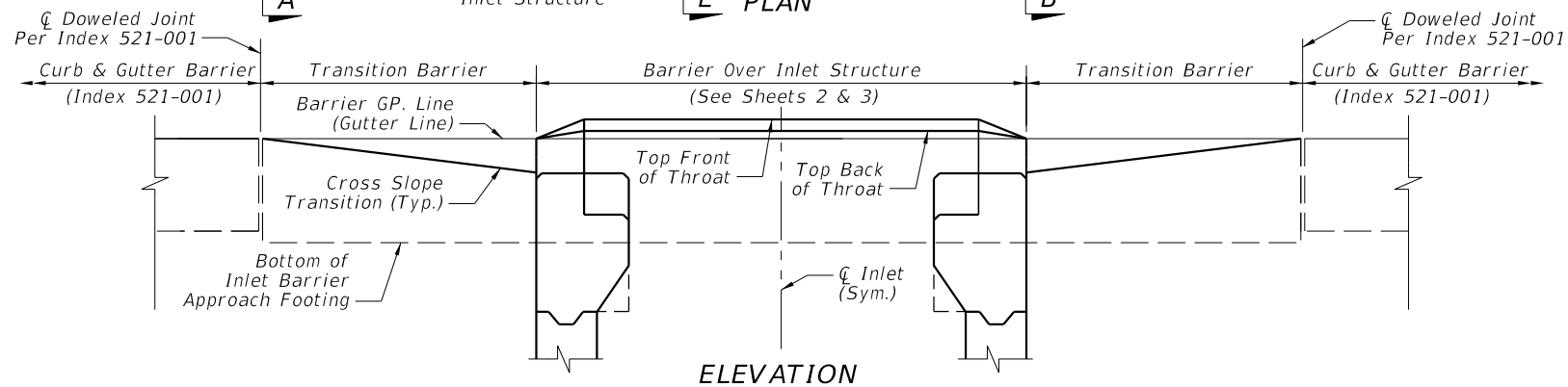

ELEVATION

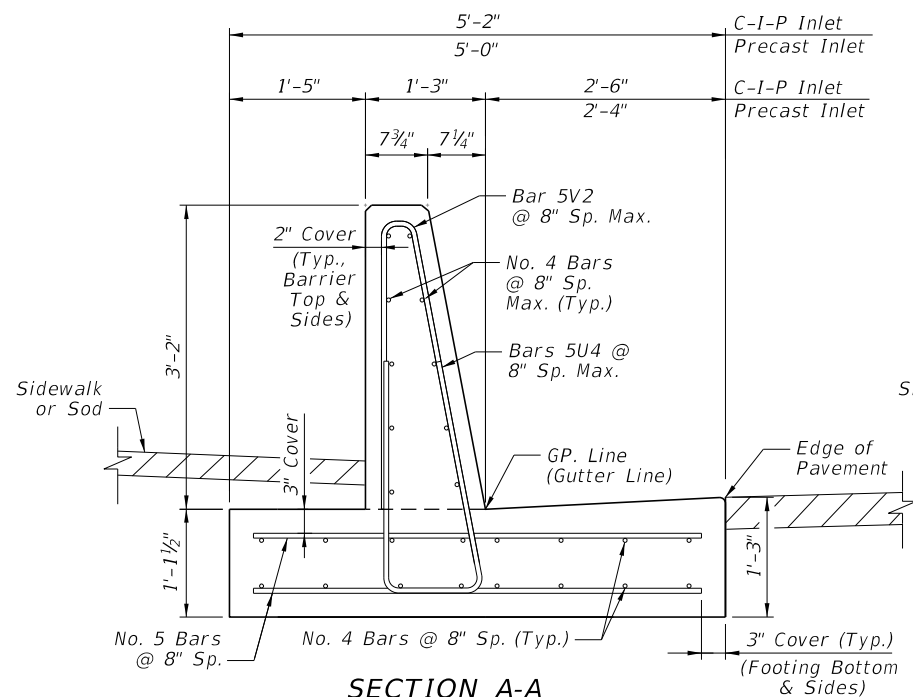

SECTION A-A
TRANSITION BARRIER
BEGIN CROSS-SLOPE TRANSITION
(ALIGN WITH CURB AND GUTTER
BARRIER, SEE INDEX 521-001)

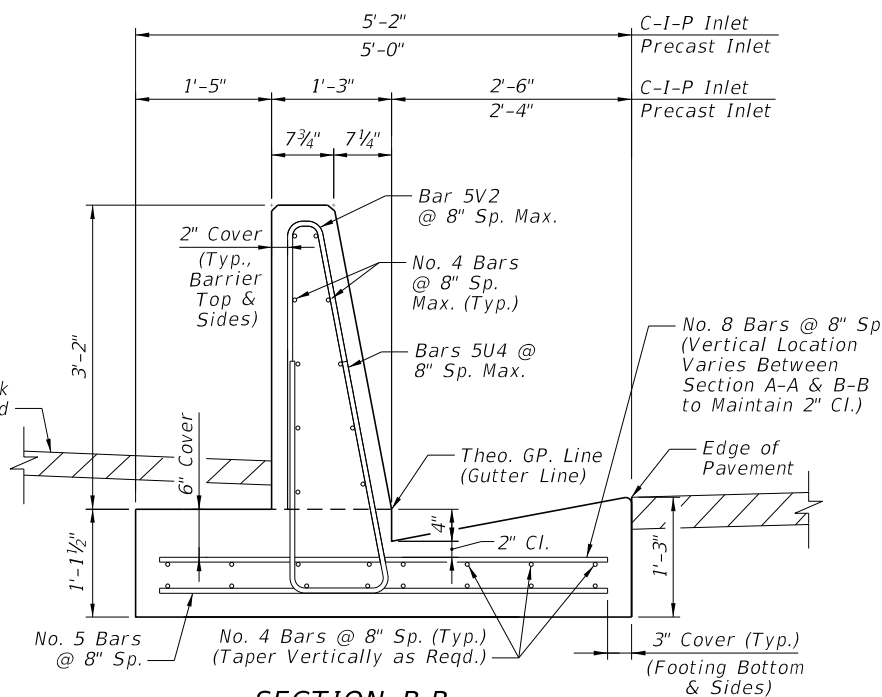

SECTION B-B
TRANSITION BARRIER
END CROSS-SLOPE TRANSITION
(ALIGN WITH INLET STRUCTURE)

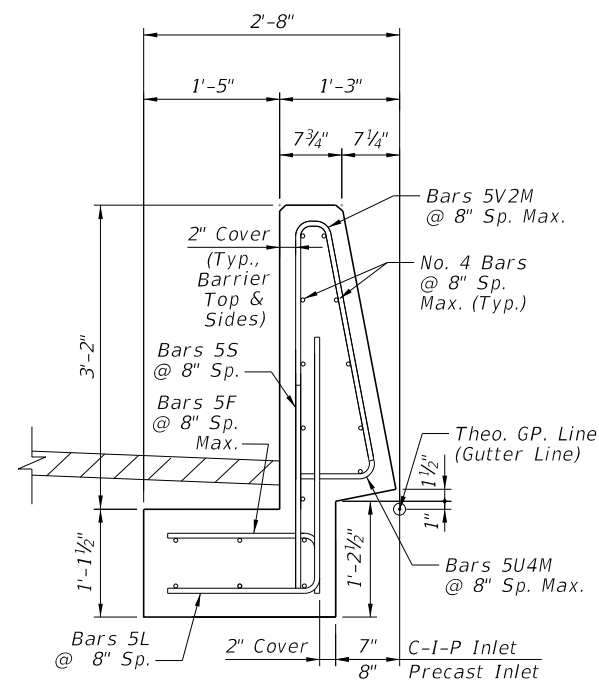

SECTION C-C
BARRIER OVER INLET STRUCTURE
(THROAT FULLY TRANSITIONED)

GENERAL NOTES:

- Where called for in the Plans, use this inlet in conjunction with Curb and Gutter Barrier per Index 521-001. Construct Barrier segments shown herein in accordance with requirements of Index 521-001, including connections to adjacent barrier segments using the Doweled Joint.
- Reinforcing shown is grade 60 steel bars. For the equivalent area of welded wire reinforcement for the inlet, see Index 425-001. Reinforcing shall have 2" minimum cover unless otherwise shown. Trim or bend bars to provide 1 1/2" clearance around pipe openings. The cost for additional reinforcing in the barrier is included in the cost of the concrete barrier.
- For Bar Bending Details of Bars 5V2 & 5U4, see Index 521-001. For all others, see Sheet 2 & 3.
- All barrier is Class II or IV concrete per Index 521-001.
- Apply a 3/4" chamfer or 1/4" radius to all exposed concrete edges.
- For pipe connections to inlet structure bottoms, the recommended maximum pipe sizes are 18" longitudinal and 30" transverse. For larger pipe, use Alternate B bottoms, Index 425-010.
- Grates may be fabricated with reticulate bars or with either 1/2" dia welded or 3/8" dia electroforged cross bars and bearing bars as detailed on Sheet 3.
- When Alternate G grate is specified in the plans, the grate is to be hot-dip galvanized after fabrication, in accordance with Specification 962-9.
- For Pay Item purposes, the depth of the barrier inlet shall be computed using the center of box grate elevation, minus either the flow line elevation of the lowest pipe flow line or the top of the sump floor elevation.
- All dimensions are for both precast and cast in place (C-I-P) inlets unless otherwise indicated.
- For inlets placed in areas of bicycle traffic, provide the extended crossbar or bar stub (See Insets "B" and "B ALTERNATE").
- Inlets to be paid for under the contract unit price for Inlets, Barrier Rigid, Curb and Gutter, Each.
- Concrete Barrier to be paid for under the contract unit price for Shoulder Concrete Barrier, Rigid-Curb & Gutter, LF.

BARRIER SECTIONS

10/30/2018 8:44:22 AM

LAST REVISION 11/01/17	REVISION	DESCRIPTION:	 FY 2019-20 STANDARD PLANS	CURB AND GUTTER BARRIER INLET	INDEX 425-032	SHEET 1 of 3
---------------------------	----------	--------------	-----------------------------------------------------------------------------------------------------------------------	-------------------------------	------------------	-----------------

10/30/2018 8:44:25 AM

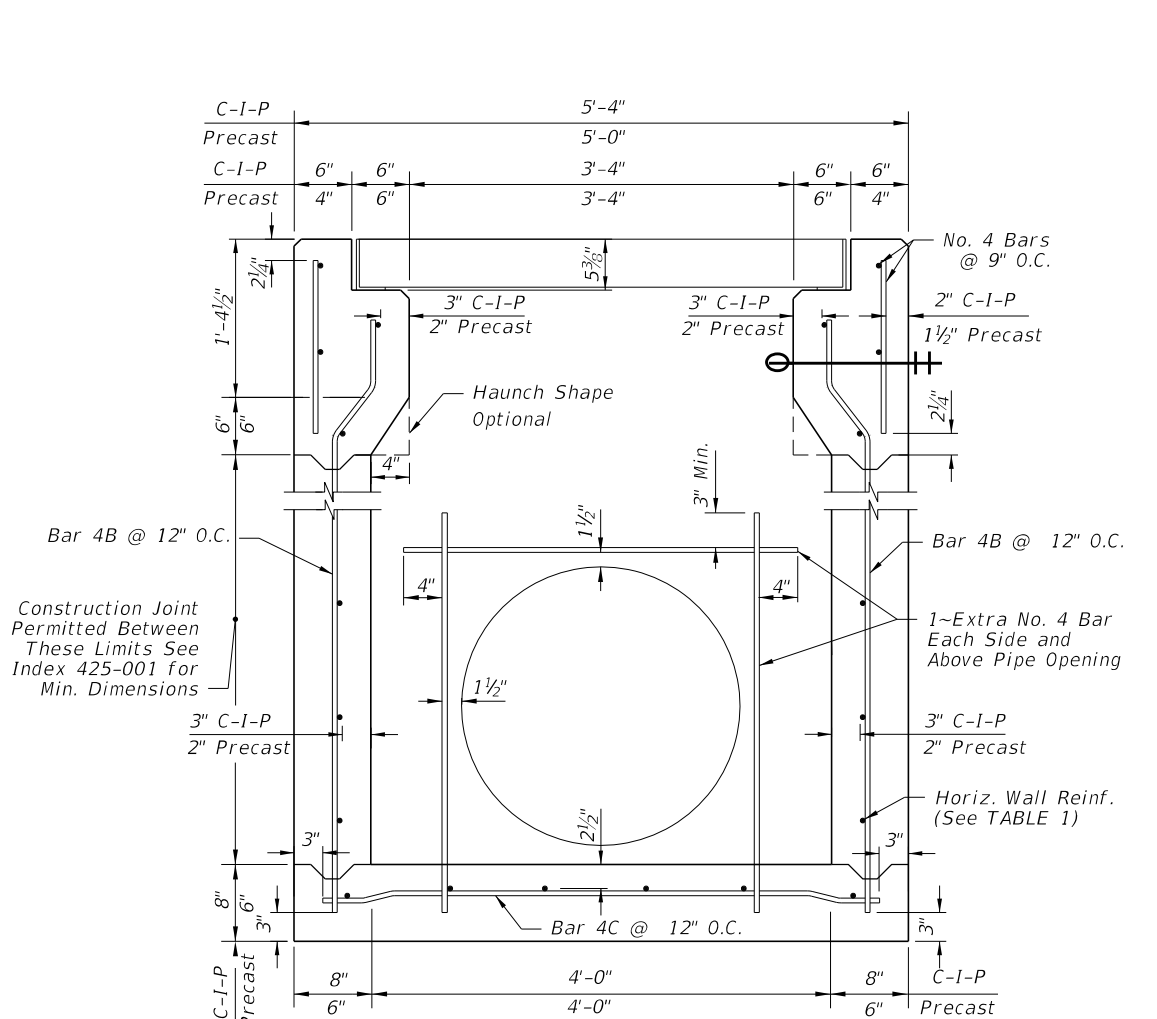

**SECTION D-D
INLET STRUCTURE**
(18" Dia. Pipe Opening Shown)

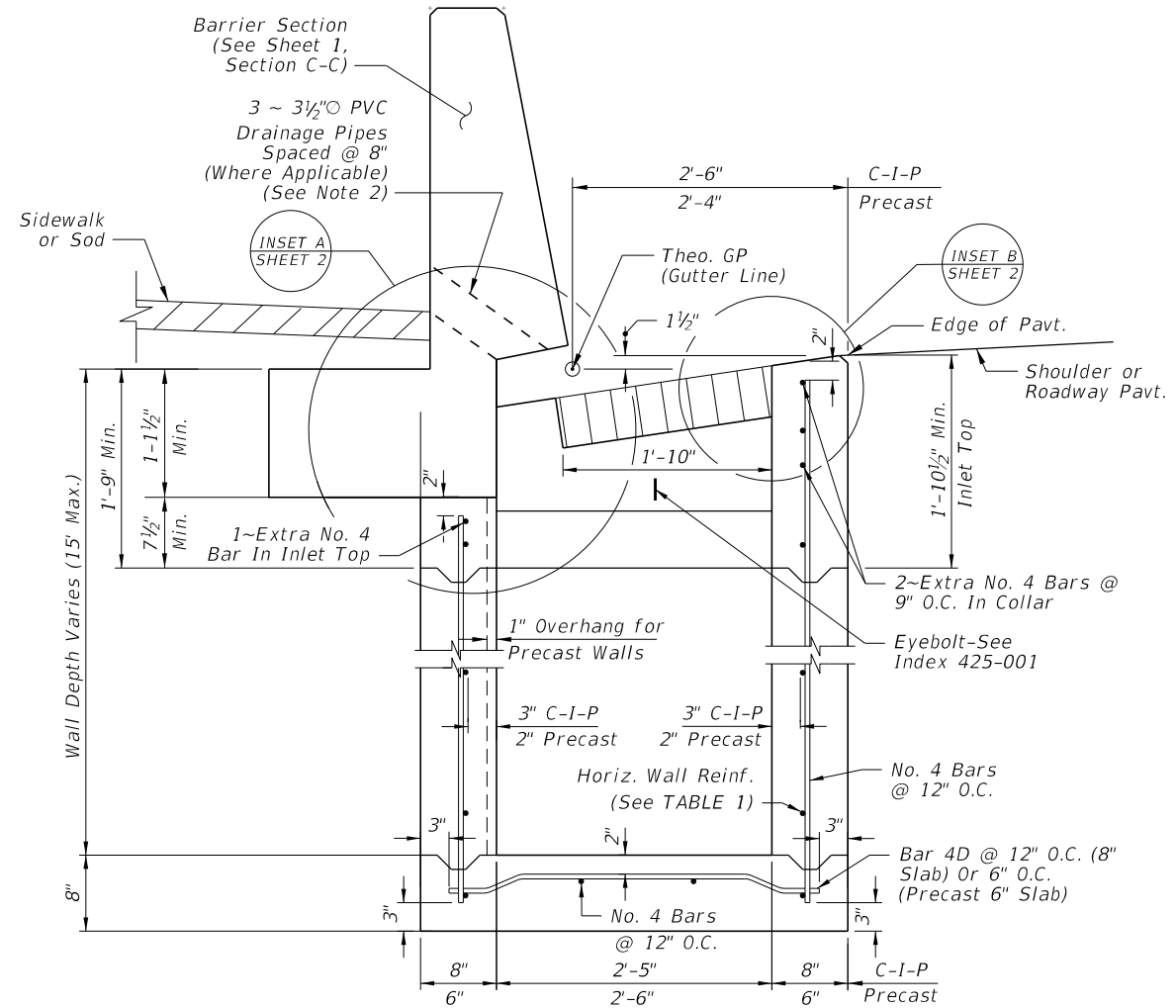

SECTION E-E
(Pipe Opening Not Shown)
(Barrier Reinforcing Steel Not Shown,
See Sheet 1, Section C-C)

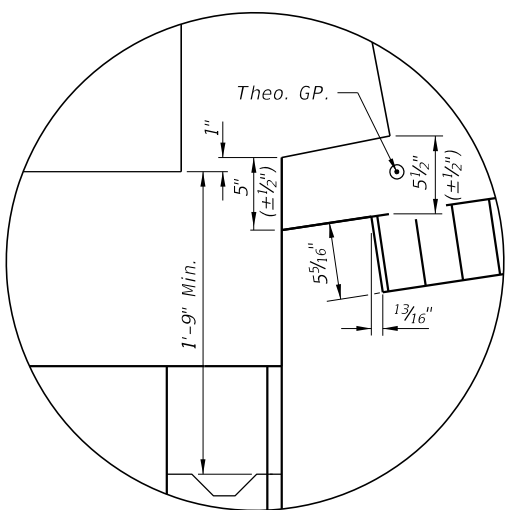

INSET A

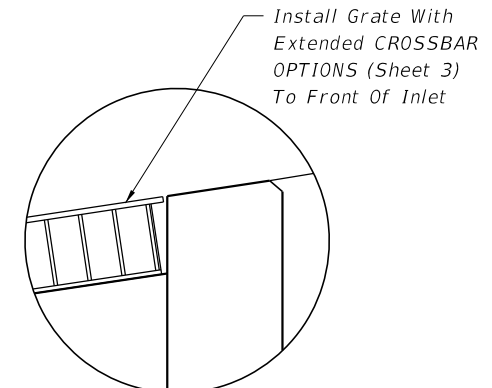

INSET B
(See General Note 10)

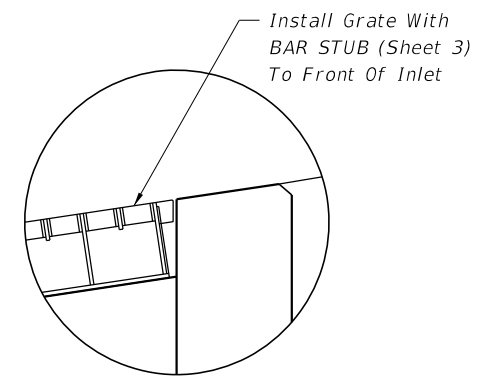

INSET B ALTERNATE
(See General Note 10)

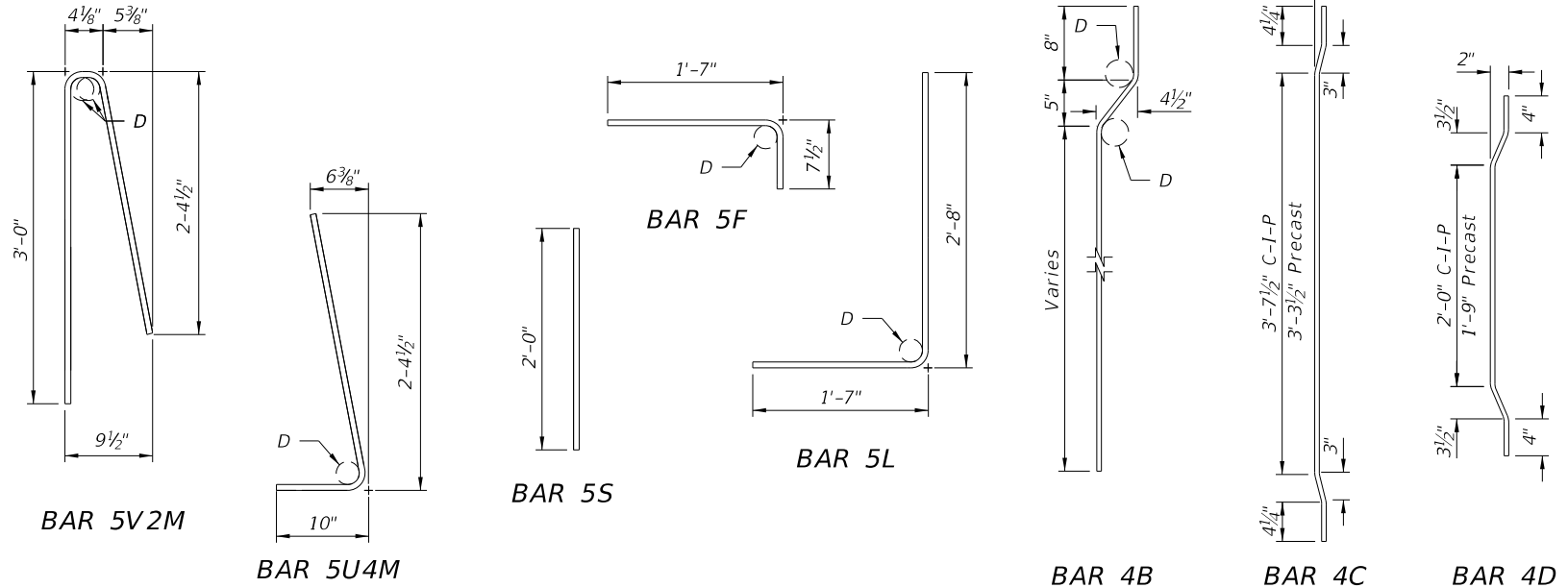

BAR BENDING DIAGRAMS

WALL DEPTH C-I-P PRECAST	SCHEDULE	AREA (in. ² /ft.)	MAX. SPACING BARS	WWR
0'-4"	A12	0.20	12"	8"
4'-9"	A6	0.20	6"	5"
9'-15"	B5.5	0.24	5 1/2"	5"
10'-15"	C6.5	0.37	6 1/2"	6"

**TABLE 1: HORIZONTAL
WALL REINFORCING SCHEDULE**

- NOTES:**
- For Bar Bending Diagrams of Bars 5V2 & 5U4, See Index 521-001. Bars 5V2M, 5U4M, & 5S may be field cut from Bars 5V2 & 5U4.
 - Install PVC drainage pipes at the inlet centerline when the inlet is located in a sag curve or when drainage pipes are called for in the plans. Install a quantity of 3 ~ 3 1/2" (I.D.) NPS Schedule 40 Pipes longitudinally spaced at 8", with the center pipe as near to the inlet centerline as practical without conflicting with the steel reinforcing.

LAST REVISION 11/01/17	DESCRIPTION:
---------------------------	--------------

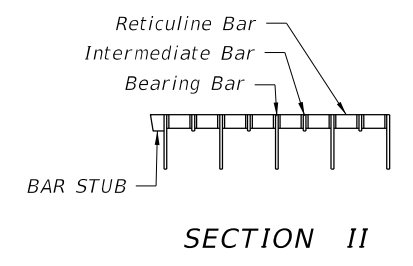
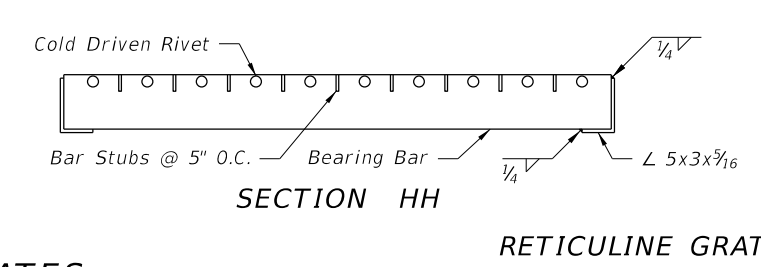
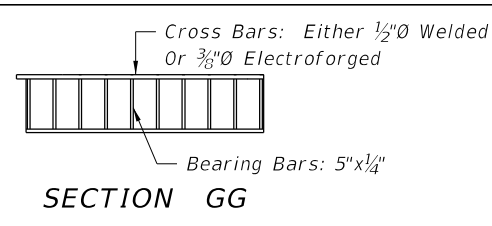
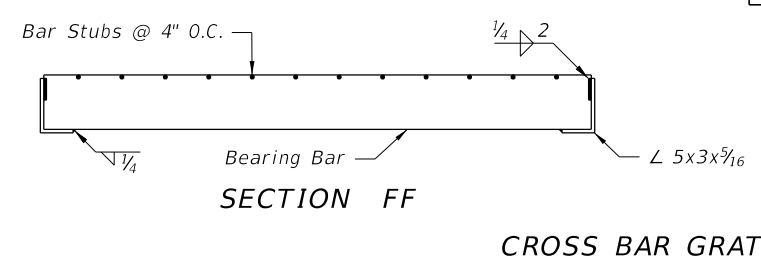
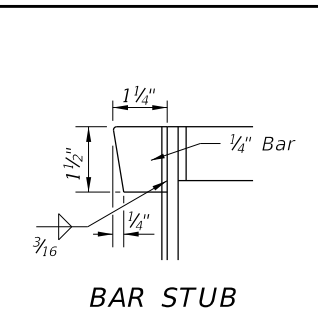
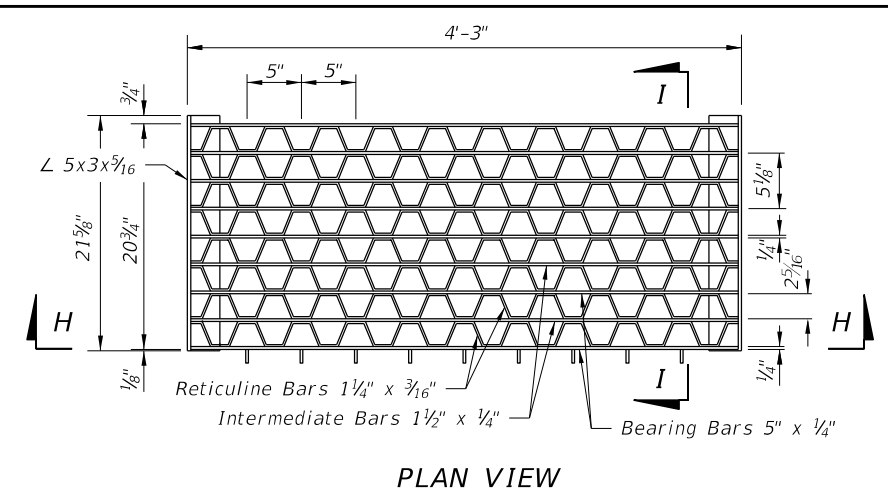
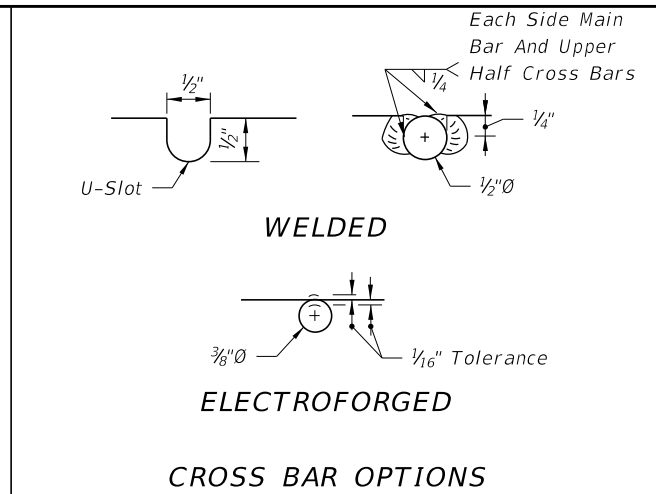
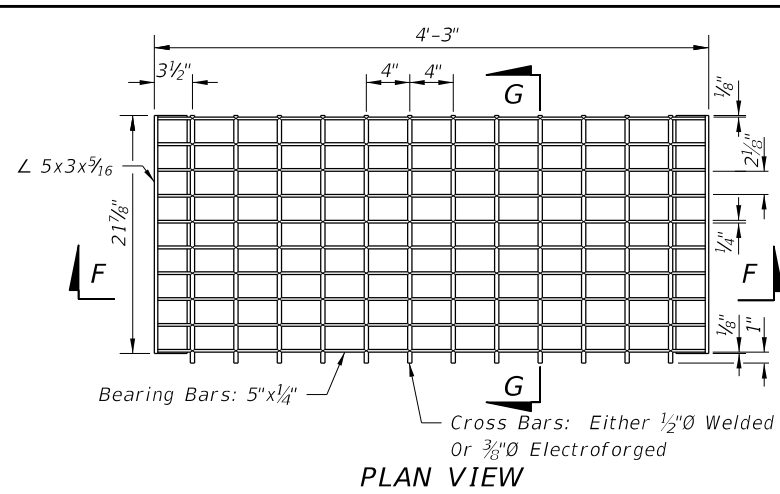

OPTIONAL STEEL GRATES

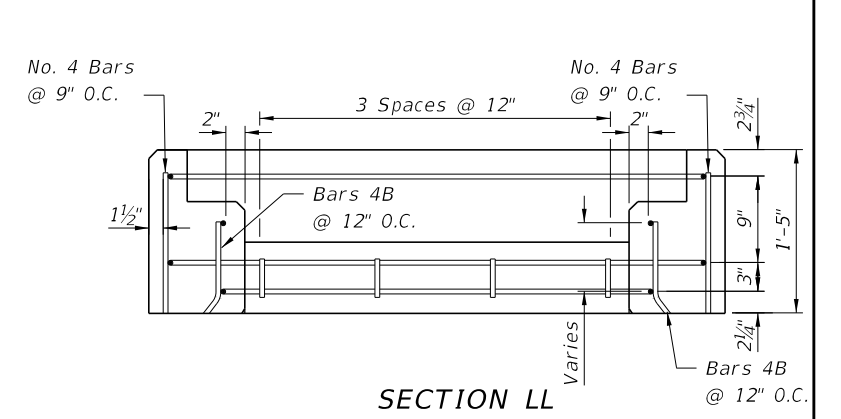
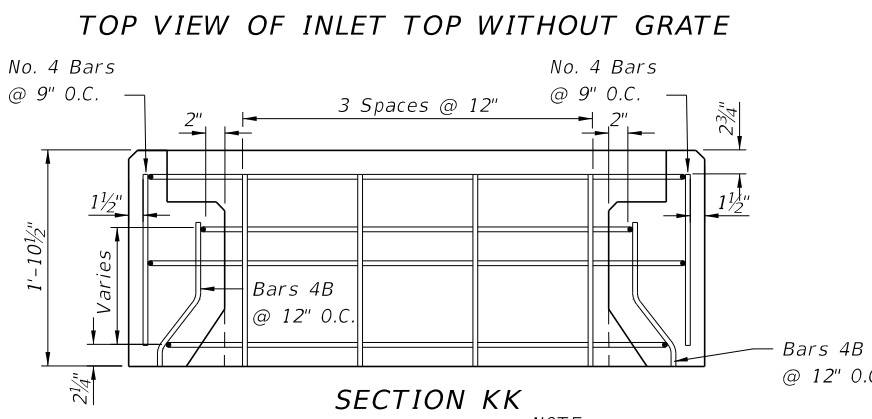
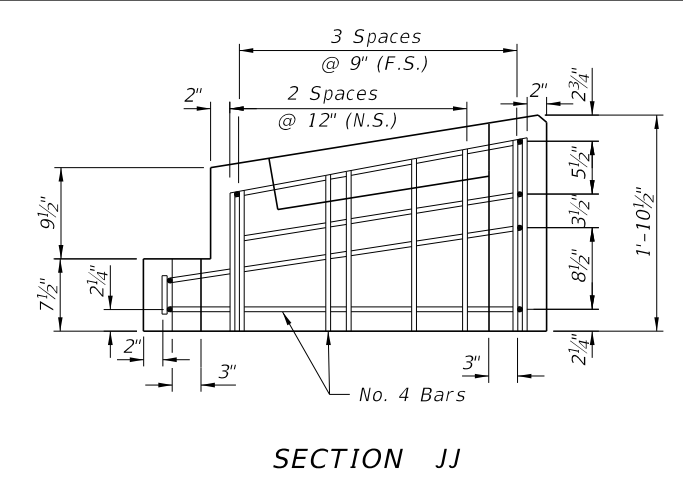
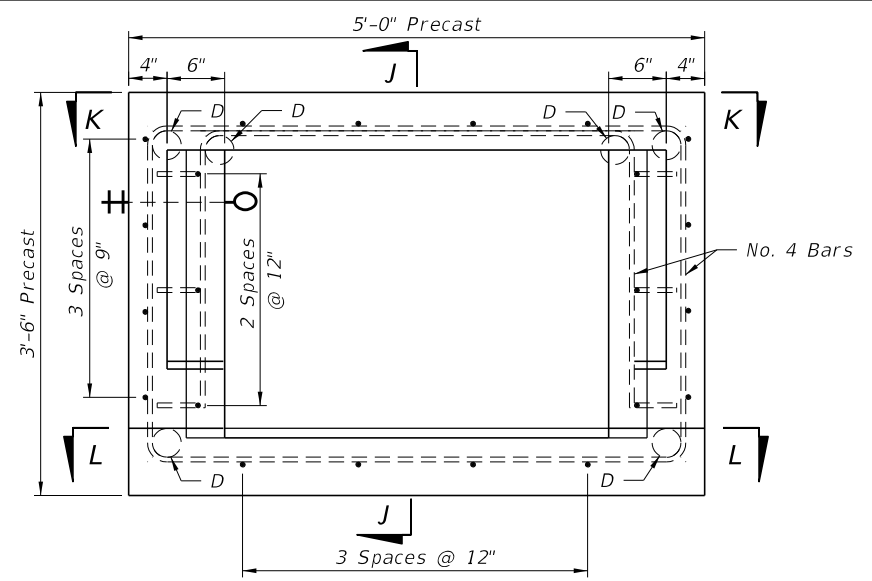
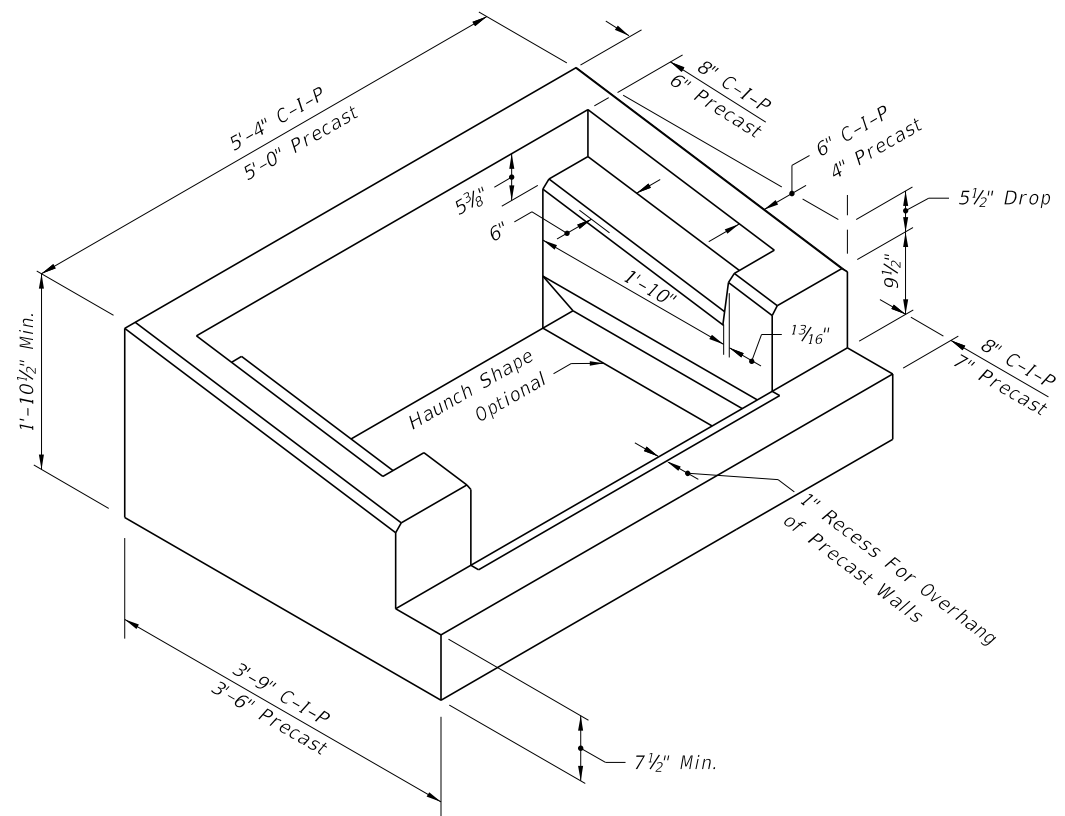

NOTE:
 1. For additional information on Bar 4B, see BAR BENDING DIAGRAMS (Sheet 2).
 2. C-I-P Inlet Top Reinforcing Similar

PRECAST INLET TOP REINFORCING DETAILS

10/30/2018 8:44:29 AM

LAST REVISION 11/01/17	DESCRIPTION:
---------------------------	--------------

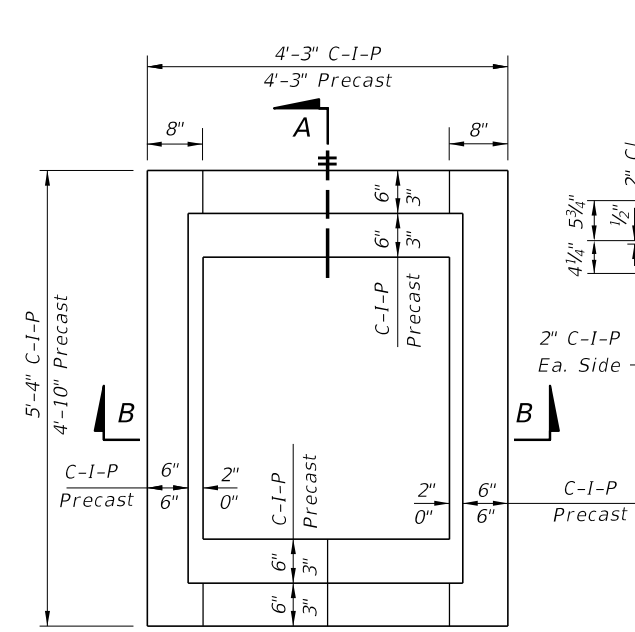

PLAN
(CAST-IN-PLACE INLET WITHOUT GRATE SHOWN, PRECAST INLET SIMILAR)

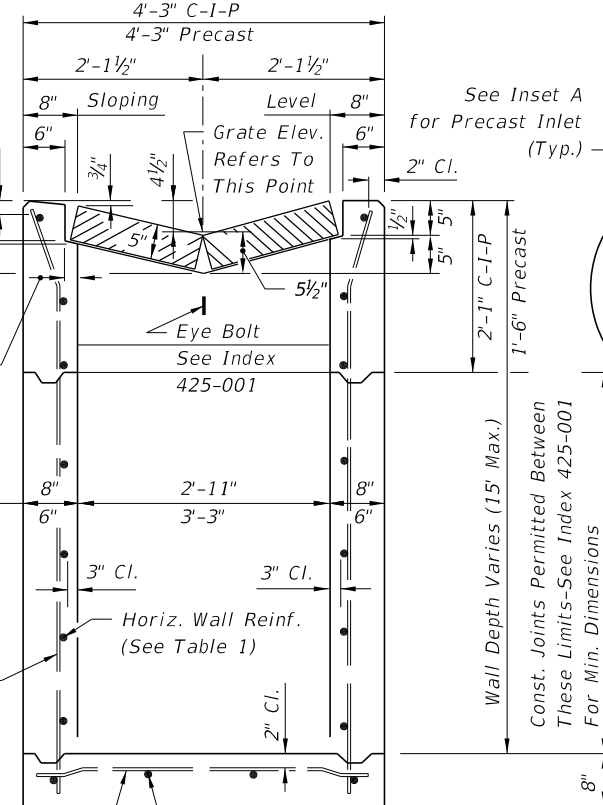

SECTION BB
(CAST-IN-PLACE INLET SHOWN, PRECAST INLET SIMILAR)

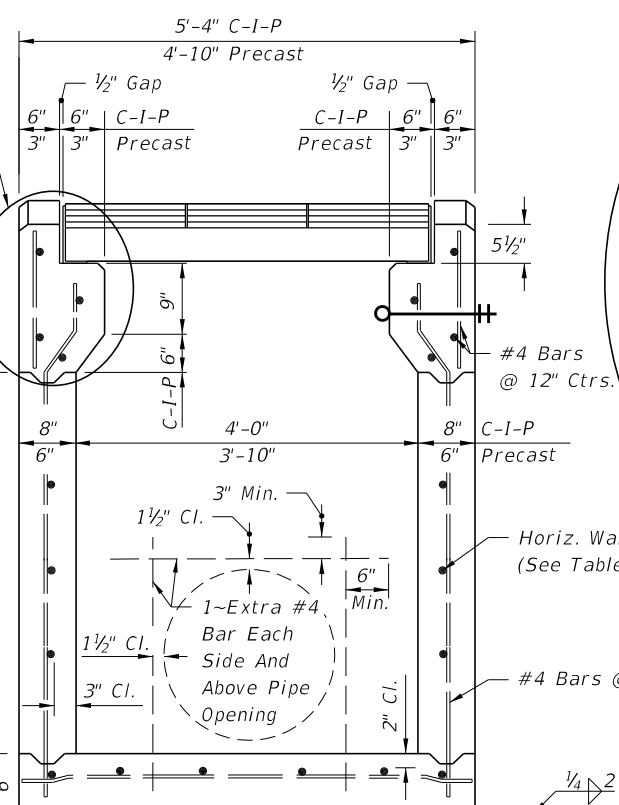

SECTION AA
(PIPE OPENING SHOWN)

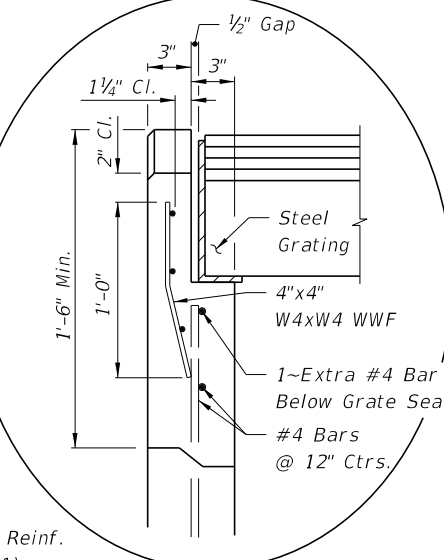

INSET A
(PRECAST OPTION)

RECOMMENDED MAXIMUM PIPE SIZES	
INLET INSIDE WIDTH	PIPE SIZE
2'-11" or 3'-3"	24"
4'-0" or 3'-10"	30"

Note: Recommended sizes are for concrete pipe. Sizes for other types of pipe must be verified for fit in accordance with Index 425-001. For larger pipe see bottom detail below and Index 425-010.

HORIZONTAL WALL REINFORCING SCHEDULE (TABLE 1)				
WALL DEPTH	SCHEDULE	AREA (in ² /ft)	MAX. SPACING	
			BARS	WWF
0'-5'	A12	0.20	12"	8"
5'-9'	A6	0.20	6"	5"
9'-12'	A4	0.20	4"	3"
9'-15'	B5.5	0.24	5 1/2"	5"

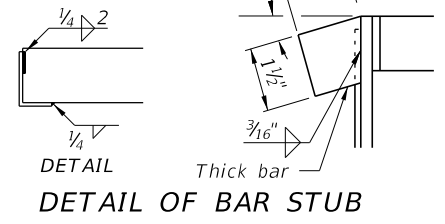

DETAIL OF BAR STUB

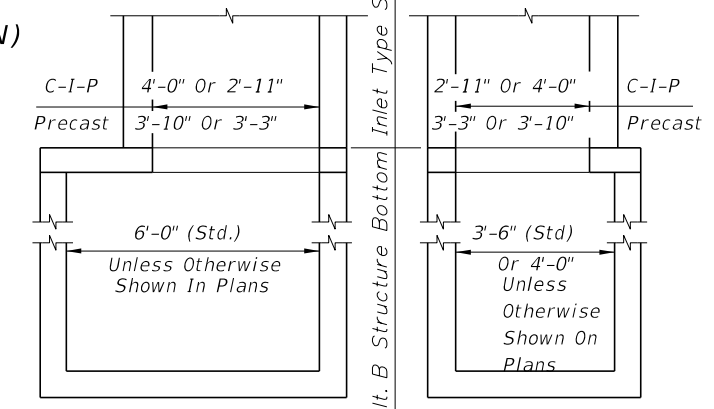

NOTE: Alt. B Structure Bottom Only. See Index 425-010 for structure bottom details and hole reinforcement.
INLET WITH STRUCTURE BOTTOM

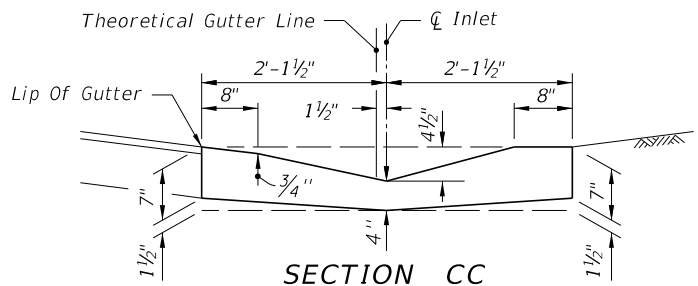

SECTION CC

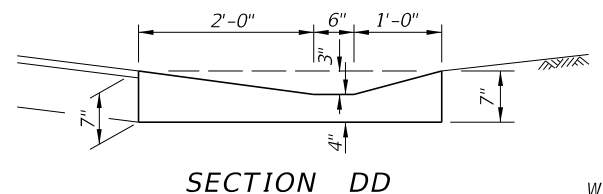

SECTION DD

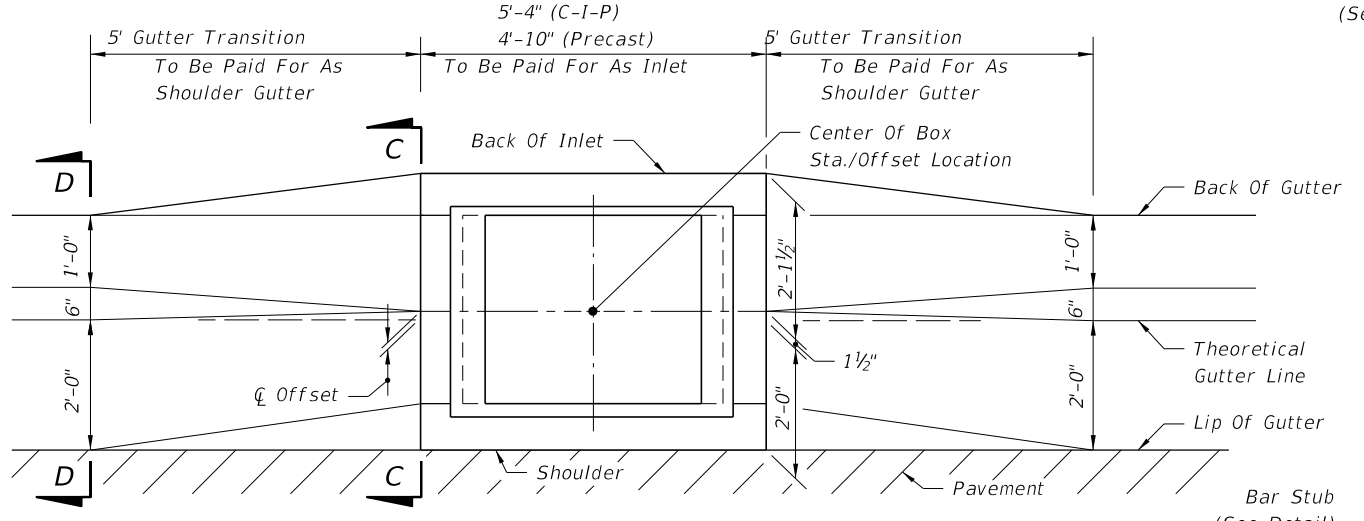

SHOULDER GUTTER TRANSITION

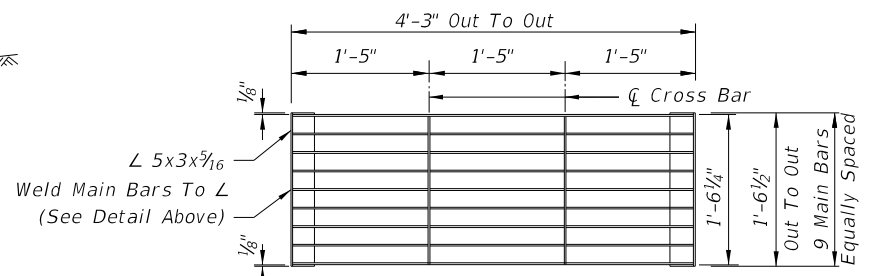

TOP VIEWS

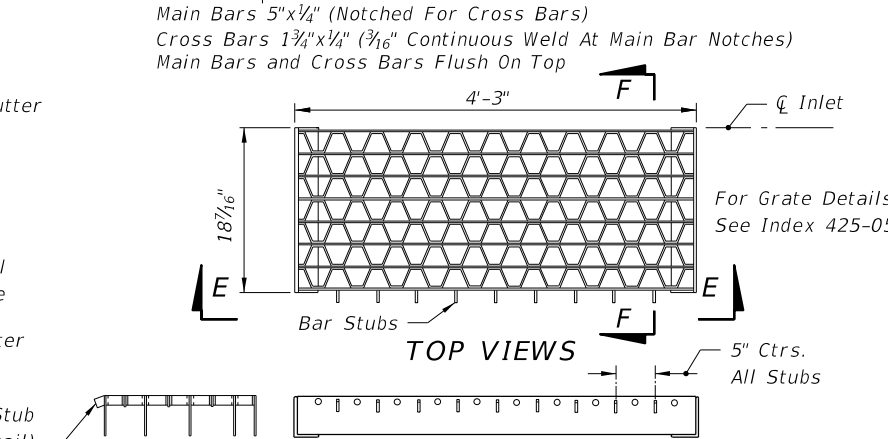

SECTION EE
STEEL GRATE

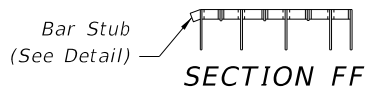

SECTION FF

- GENERAL NOTES**
1. This inlet is intended for use in shoulder gutter on facilities subject to heavy wheel loads.
 2. All reinforcing is Grade 60 bars with 2" min. cover unless otherwise noted. See Index 425-001 for equivalent area of welded wire fabric. Bars to be cut or bent for 1 1/2" minimum clearance around pipe.
 3. All exposed edges and corners must be 3/4" chamfer or tooled to 1/4" radius.
 4. When Alternate G grate is specified in plans, the grate is to be hot-dip galvanized after fabrication.
 5. For supplementary details and notes see Indexes 425-001 and 425-010.
 6. All dimensions are for both precast and cast-in-place inlets unless otherwise noted.
 7. Inlets to be paid for under the contract unit price for inlets (Gutter Type S), EA. Cost of concrete apron at terminal inlets to be included in the cost of the inlet.

10/30/2018 8:44:33 AM

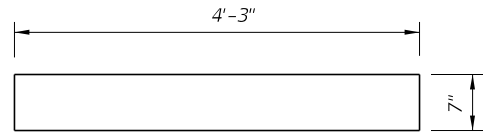

SECTION BB
(Enlarged)

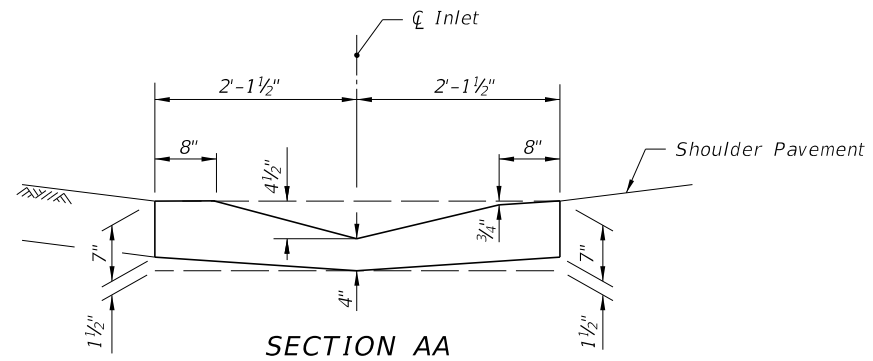

SECTION AA
(Enlarged)

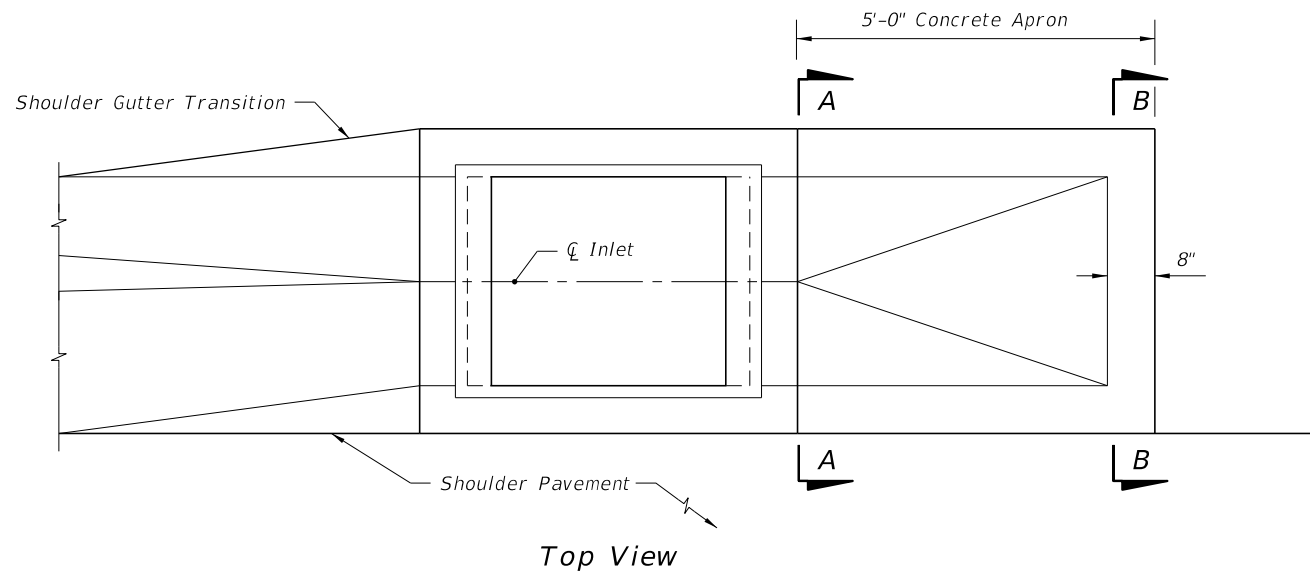

Top View

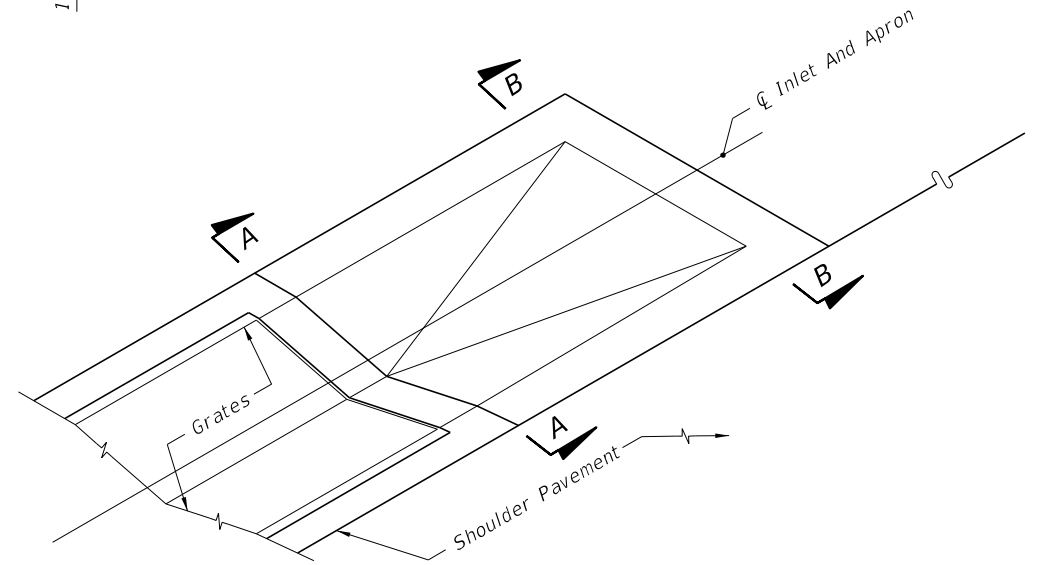

PICTORIAL VIEW

Apron To be Constructed At The Most Downstream Inlet In A Run Of Shoulder Gutter
CONCRETE APRON AT TERMINAL INLETS

10/30/2018 8:44:37 AM

LAST REVISION
11/01/17

REVISION DESCRIPTION:



FY 2019-20
STANDARD PLANS

GUTTER INLET TYPE S

INDEX
425-040

SHEET
2 of 3

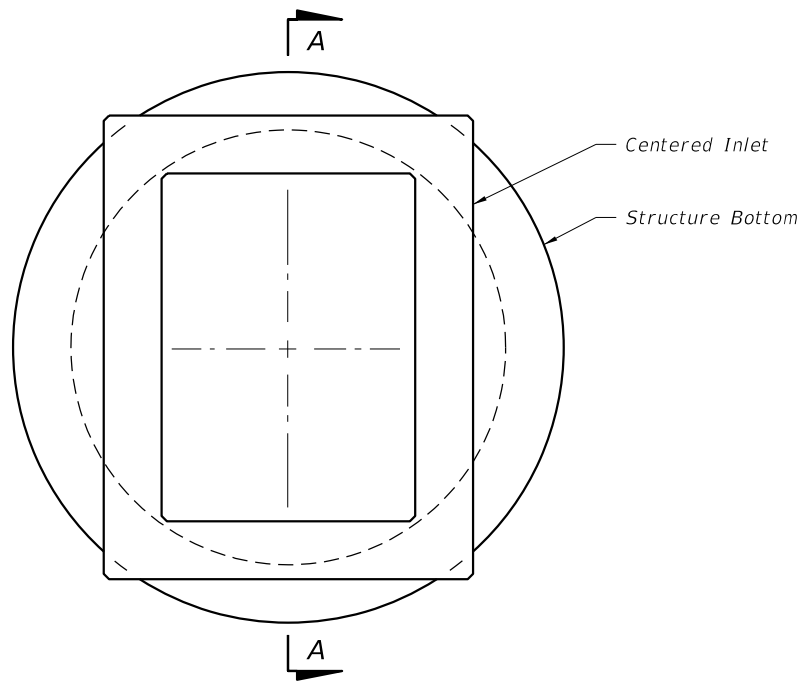

TOP VIEW

TOP SLAB OPENINGS		
DIAMETER	OPENING SIZE	
	MIN.	MAX.
5'-0" To 8'-0"	2'-11" x 4'-0"	3'-3" x 3'-10"

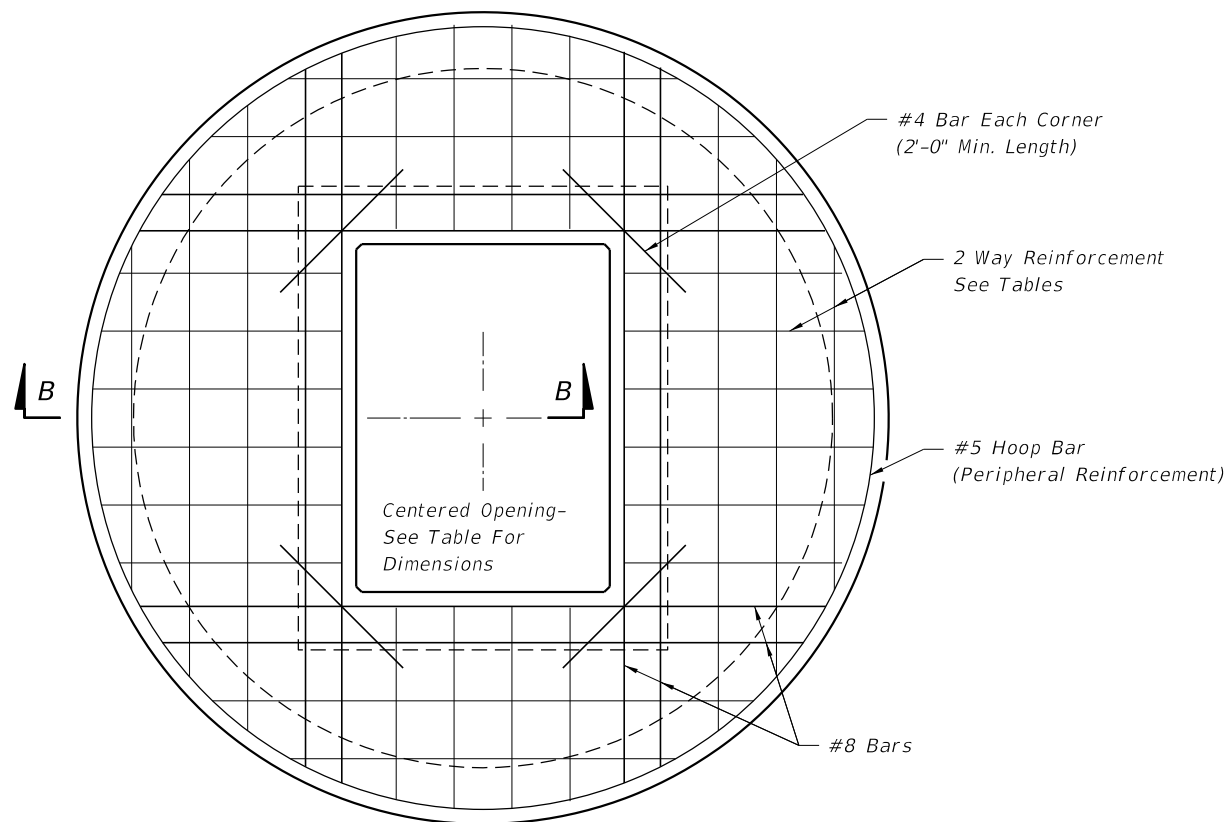

TOP SLAB REINFORCING DIAGRAM

TOP SLAB REINFORCING SCHEDULE	
GRADE 60 (BAR) OR 65 KSI & 70 KSI (WIRE FABRIC)	
SCHEDULE	In ² /ft.
A	0.20
B	0.24
C	0.37
D	0.53
E	0.73
F	1.06
G	1.45

TOP SLAB WITH CENTERED OPENING		
SLAB DEPTH	SLAB THICKNESS	REINFORCING (2 WAYS) SCHEDULE
SIZE: 5'-0"		
≥0.5' < 30'	9½"	C
30' - 40'	9½"	D
SIZE: 6'-0"		
≥0.5' < 8'	9½"	B
8' < 18'	9½"	C
18' < 30'	9½"	D
30' < 37'	9½"	E
37' - 40'	9½"	G
SIZE: 8'-0"		
≥0.5' < 9'	11½"	C
9' < 15'	11½"	D
15' < 23'	11½"	E
23' < 33'	11½"	E
33' - 40'	11½"	G

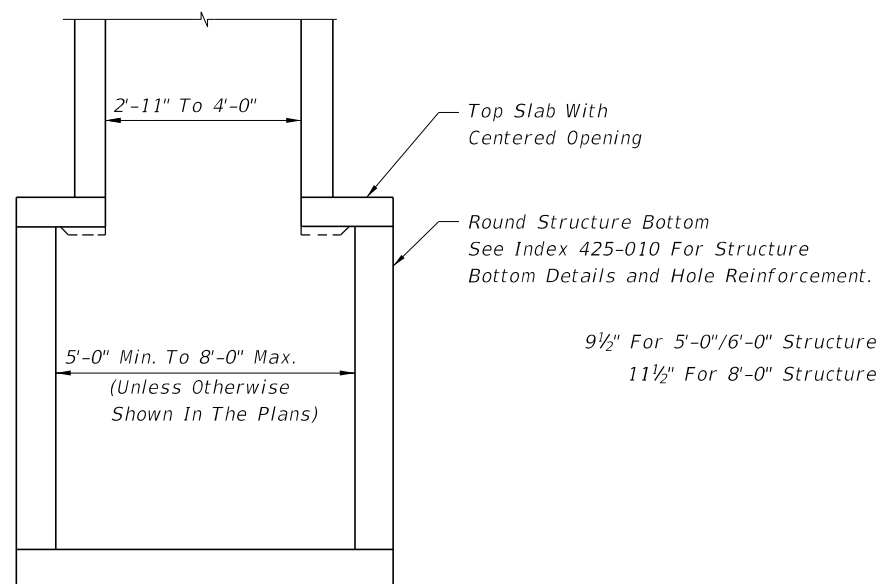

SECTION AA

9½" For 5'-0"/6'-0" Structure Bottoms
11½" For 8'-0" Structure Bottoms

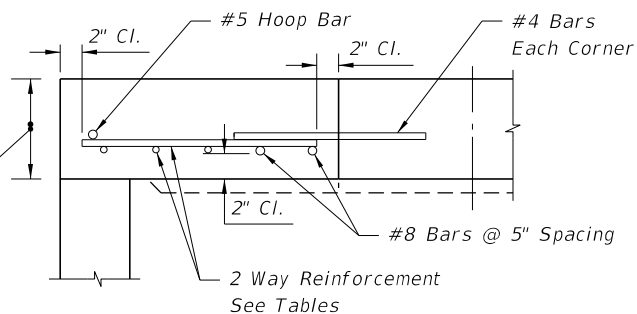

SECTION BB

ALT. A STRUCTURE BOTTOM FOR INLET TYPE S

10/30/2018 8:44:40 AM

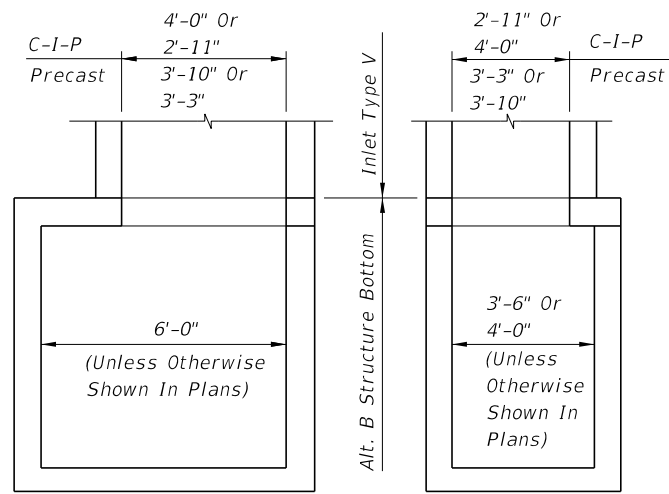

NOTE: Alt. B Structure Bottom Only. See Index 425-010 for structure bottom details and hole reinforcement.
(For Pipes 30" Dia. And Larger)
INLET WITH STRUCTURE BOTTOM

RECOMMENDED MAXIMUM PIPE SIZES

Inlet Inside Width	Pipe Size
2'-11" Or 3'-3"	24"
4'-0" Or 3'-10"	30"

Note: Recommended sizes are for concrete pipe. Sizes for other types of pipe must be verified for fit in accordance with Index 425-001. For larger pipe see bottom detail above and Index 425-010.

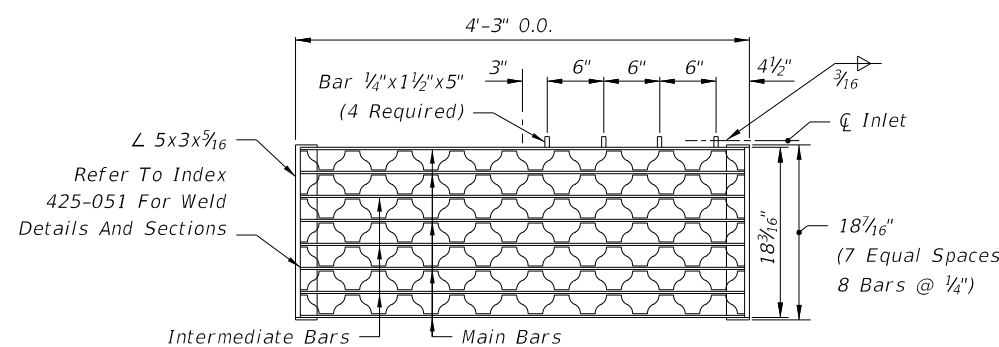
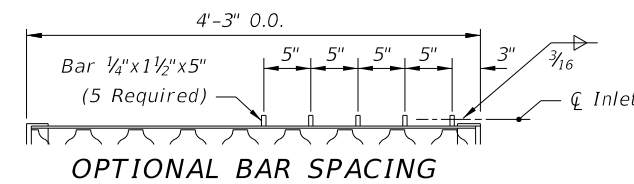

TWO REQUIRED PER INLET

5" Steel Grate: Main Bars 5"x1/4"
Intermediate Bars 1 1/2"x1/4"
Reticuline Bars 1 1/4"x3/16"

GENERAL NOTES

- This inlet is suitable for village swales, ditches, or other areas subject to heavy wheel loads, minimum debris. This inlet may be placed in areas subject to occasional pedestrian traffic such as landscaped areas and pavement areas where pedestrians can walk around the inlet. This inlet is not for use in a bicycle way.
- When alternate "G" grate is specified in plans, the grate is to be hot dip galvanized after fabrication.
- All reinforcing is Grade 60 bars with 2" min. cover unless otherwise noted. See Index 425-001 for equivalent area of welded wire fabric. Cut or bend bars out of way of pipe to clear pipe 1 1/2".
- All exposed edges and corners shall be 3/4" chamfer or tooled to 1/4" radius.
- All dimensions are for both precast and cast-in-place inlets unless otherwise noted.
- For supplementary details see Index 425-001.
- Inlet to be paid for under the contract unit price for Inlets (Gutter Type V), EA

HORIZONTAL WALL REINFORCING SCHEDULE (TABLE 1)

WALL DEPTH	SCHEDULE	AREA (in. ² /ft.)	MAX. SPACING	
			BARS	WWF
0' - 5'	A12	0.20	12"	8"
5' - 9'	A6	0.20	6"	5"
9' - 12'	A4	0.20	4"	3"
9' - 15'	B5.5	0.24	5 1/2"	5"

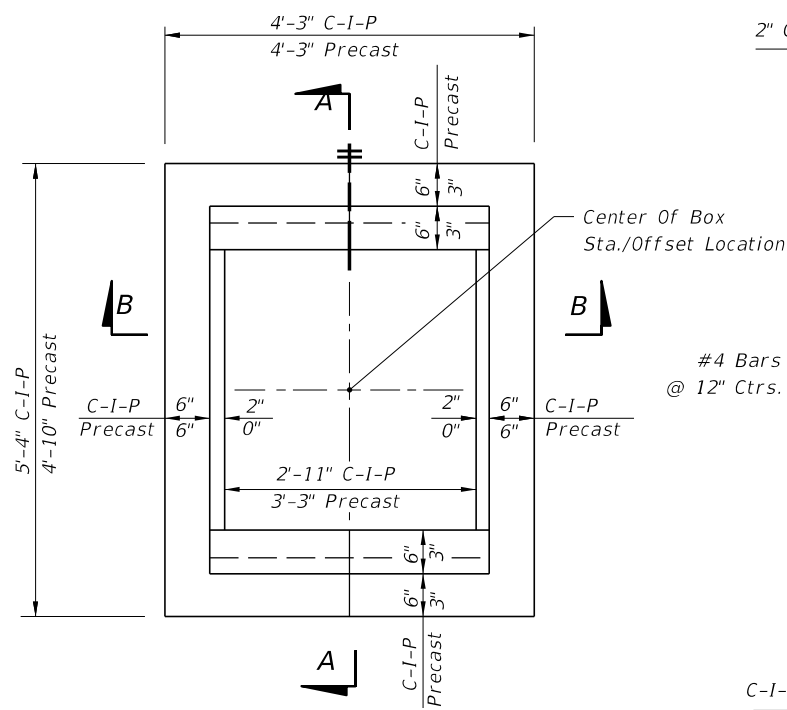

PLAN
(CAST-IN-PLACE INLET SHOWN WITHOUT GRATE; PRECAST INLET SIMILAR)

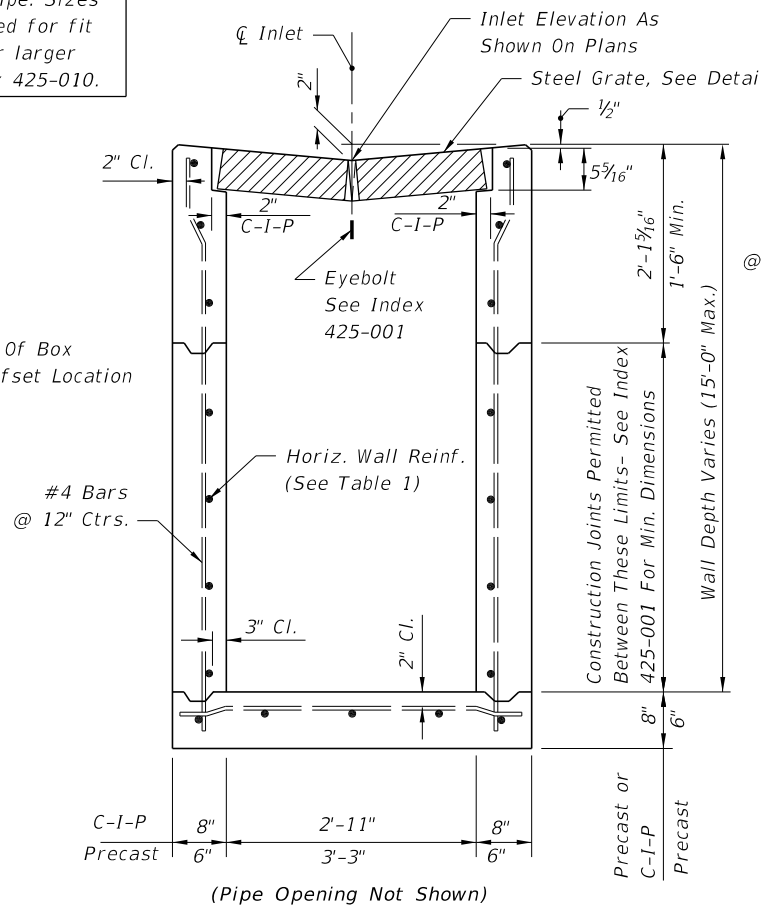

SECTION BB
(CAST-IN-PLACE INLET SHOWN PRECAST INLET SIMILAR)

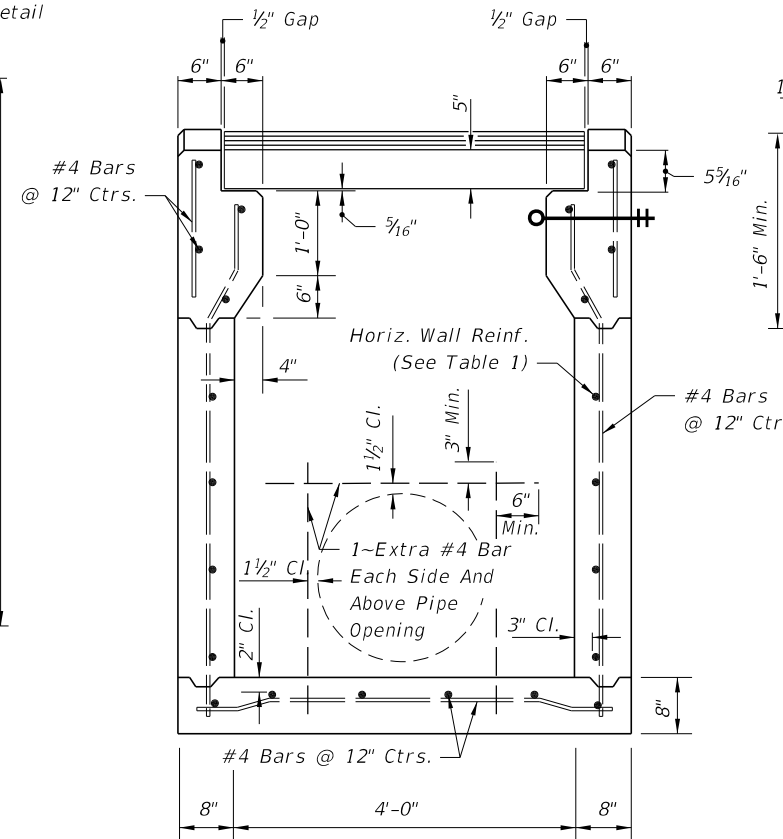

SECTION AA
(CAST-IN-PLACE INLET)

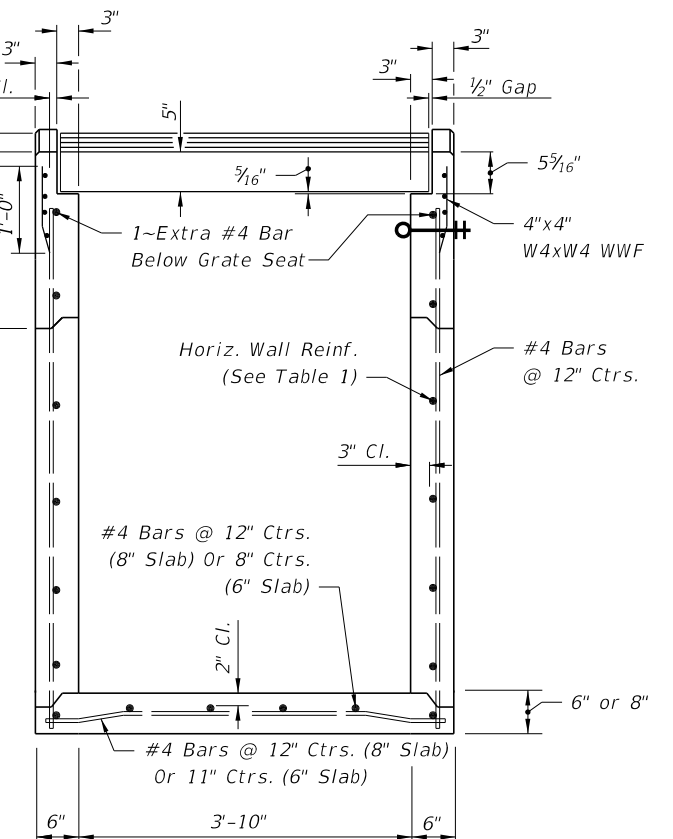

SECTION AA
(PRECAST INLET)

10/30/2018 8:44:43 AM

LAST REVISION	DESCRIPTION:
11/01/17	

**FY 2019-20
STANDARD PLANS**

GUTTER INLET TYPE V

INDEX	SHEET
425-041	1 of 2

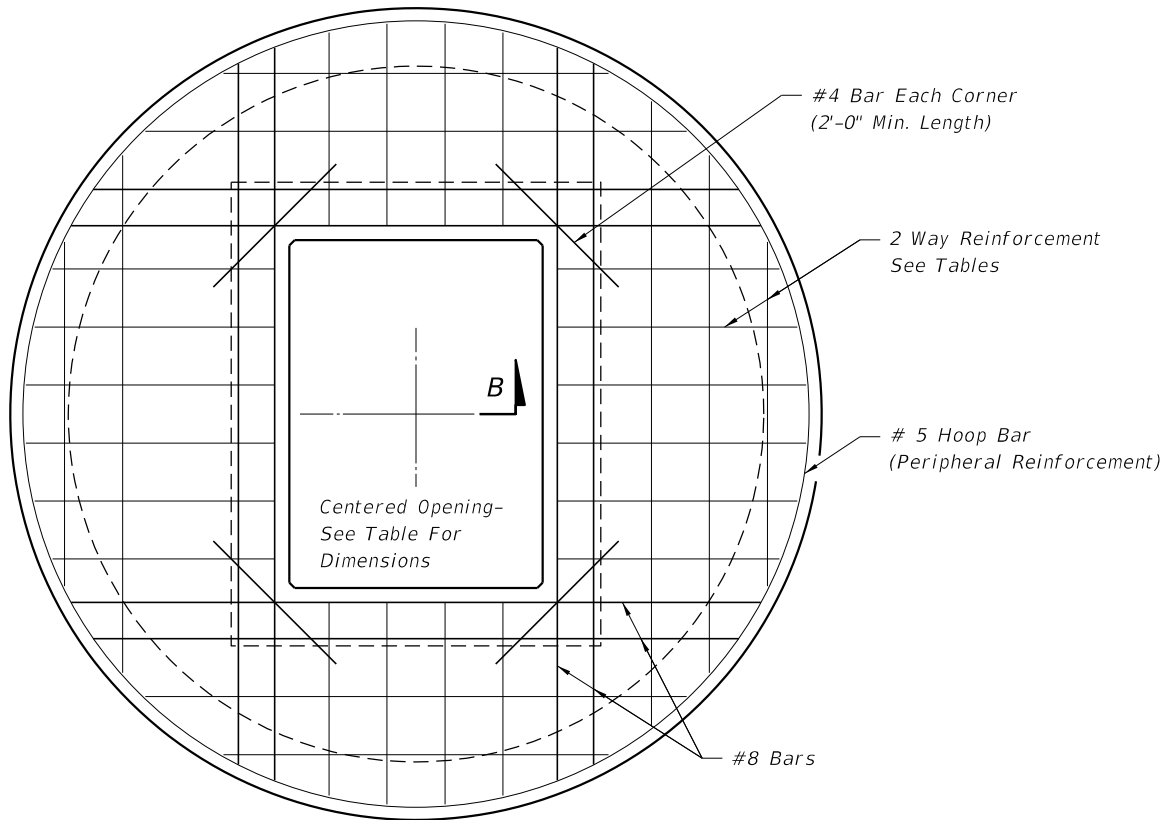
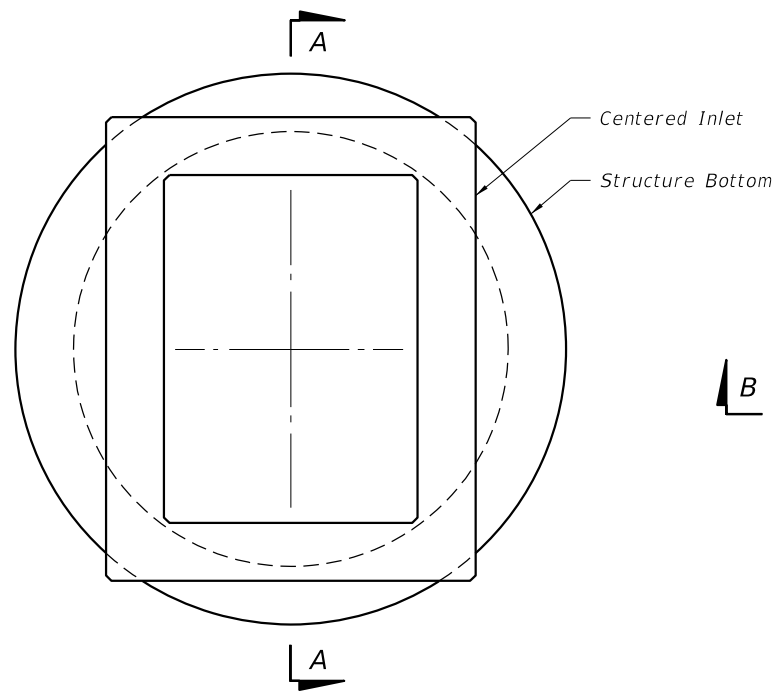

TOP SLAB REINFORCING DIAGRAM

TOP SLAB OPENINGS		
DIAMETER	OPENING SIZE	
	MIN.	MAX.
5'-0" To 8'-0"	2'-11" x 4'-0"	3'-3" x 3'-10"

TOP SLAB REINFORCING SCHEDULE	
SCHEDULE	GRADE 60 (BAR) OR 65 KSI & 70 KSI (WIRE FABRIC) In. ² /ft.
A	0.20
B	0.24
C	0.37
D	0.53
E	0.73
F	1.06
G	1.45

TOP SLAB WITH CENTERED OPENING		
SLAB DEPTH	SLAB THICKNESS	REINFORCING (2 WAYS) SCHEDULE
SIZE: 5'-0"		
≥0.5' < 30'	9½"	C
30'-40'	9½"	D
SIZE: 6'-0"		
0.5' < 8'	9½"	B
8' < 18'	9½"	C
18' < 30'	9½"	D
30' < 37'	9½"	E
37'-40'	9½"	G
SIZE: 8'-0"		
≥0.5' < 9'	11½"	C
9' < 15'	11½"	D
15' < 23'	11½"	E
23' < 33'	11½"	E
33'-40'	11½"	G

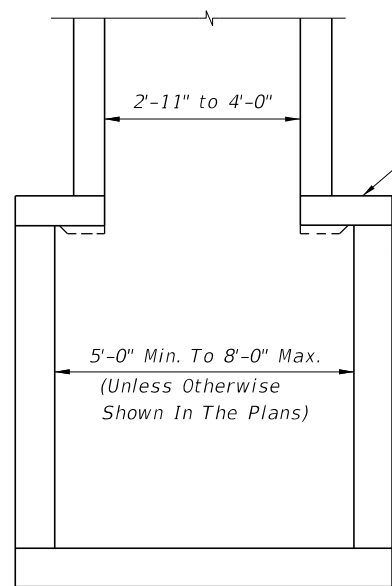

SECTION AA

Top Slab With Centered Opening
Round Structure Bottom See Index 425-010 For Structure Bottom Details and Hole Reinforcement.

9½" For 5'-0"/6'-0" Structure Bottoms
11½" For 8'-0" Structure Bottoms

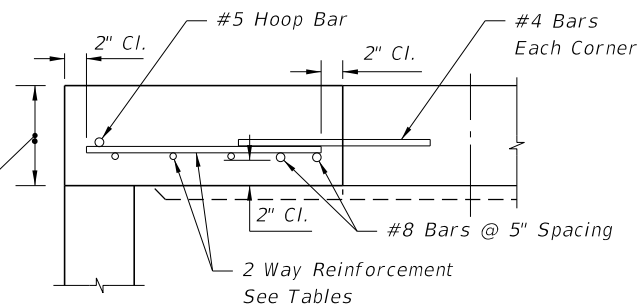

SECTION BB

ALT. A STRUCTURE BOTTOM FOR INLET TYPE V

10/30/2018 8:44:47 AM

LAST REVISION 11/01/17	DESCRIPTION:
---------------------------	--------------



FY 2019-20
STANDARD PLANS

GUTTER INLET TYPE V

INDEX
425-041

SHEET
2 of 2

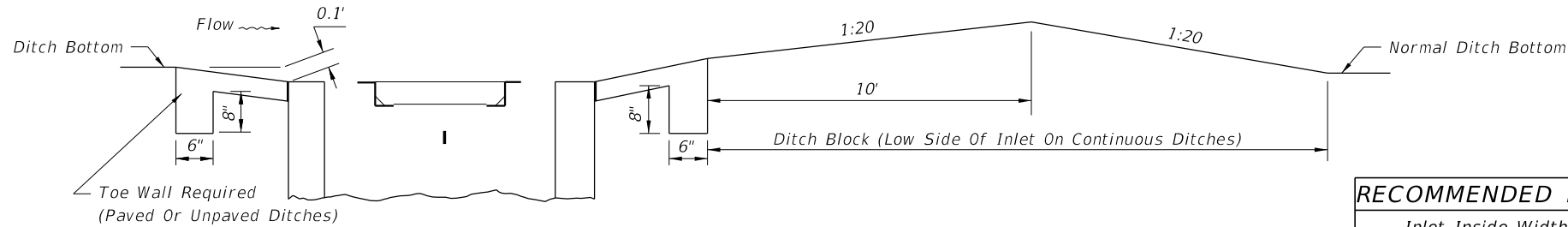

SECTION DD

RECOMMENDED MAXIMUM PIPE SIZES

Inlet Inside Width	Pipe Size
2'-0"	18"
3'-1"	24" 18" Where An 18" pipe Enters A 2'-0" Wall

Note: Recommended sizes are for concrete pipe. Sizes for other types of pipe must be verified for fit in accordance with Index 425-001. For larger pipe see bottom detail right and Index 425-010.

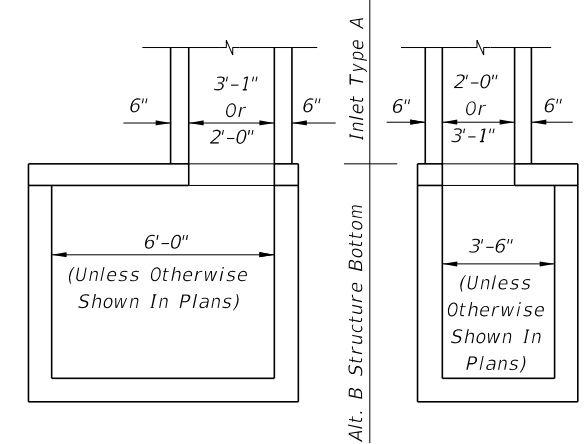

NOTE: Alt. B Structure Bottom Only. See Index 425-010 for Structure Bottom Details And Hole Reinforcement.

INLET WITH STRUCTURE BOTTOM

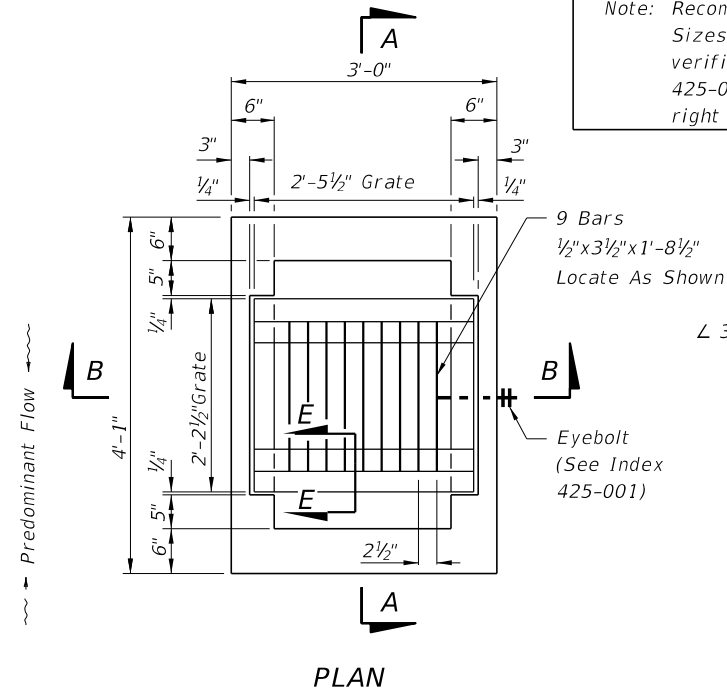
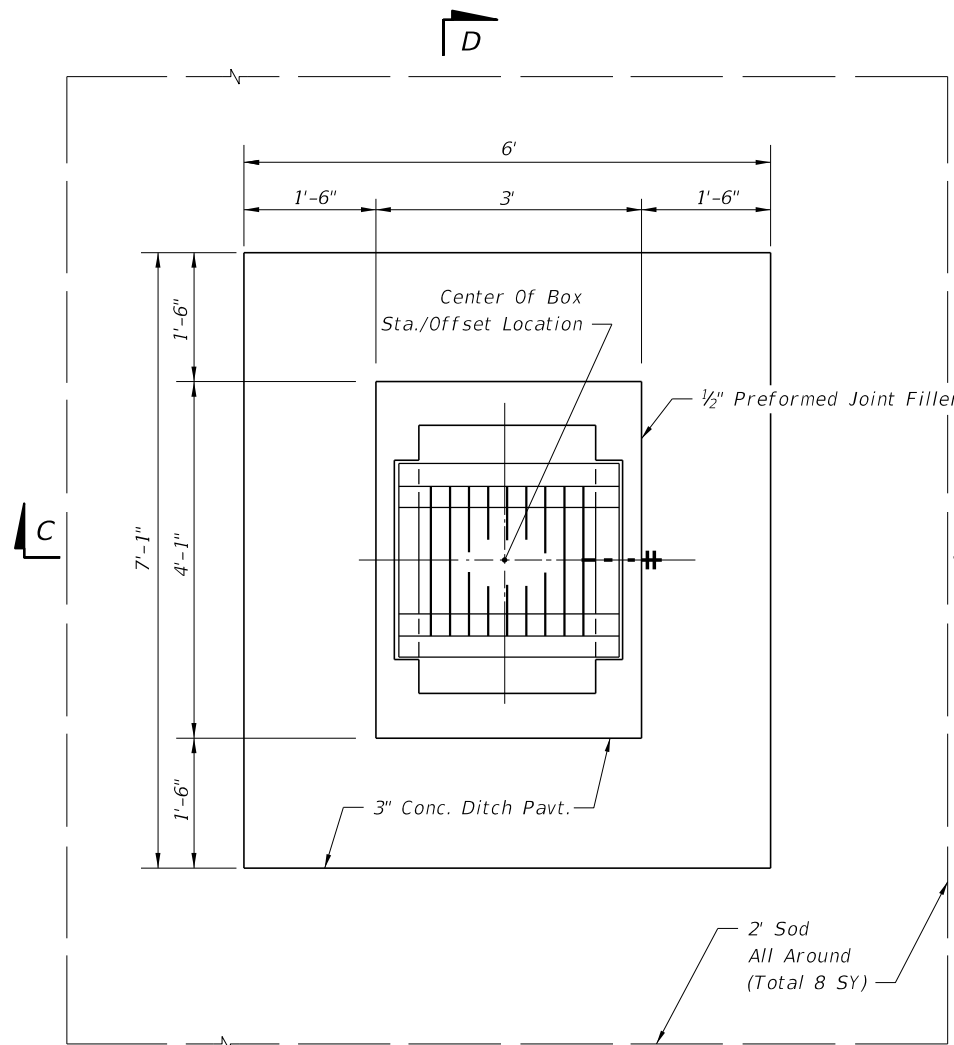

PLAN

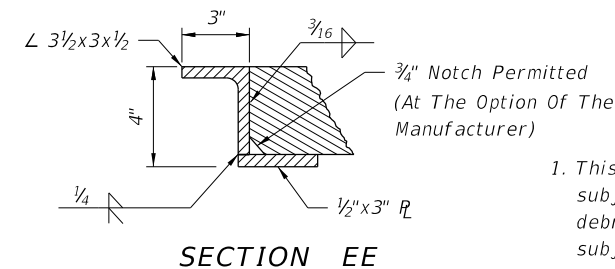

SECTION EE

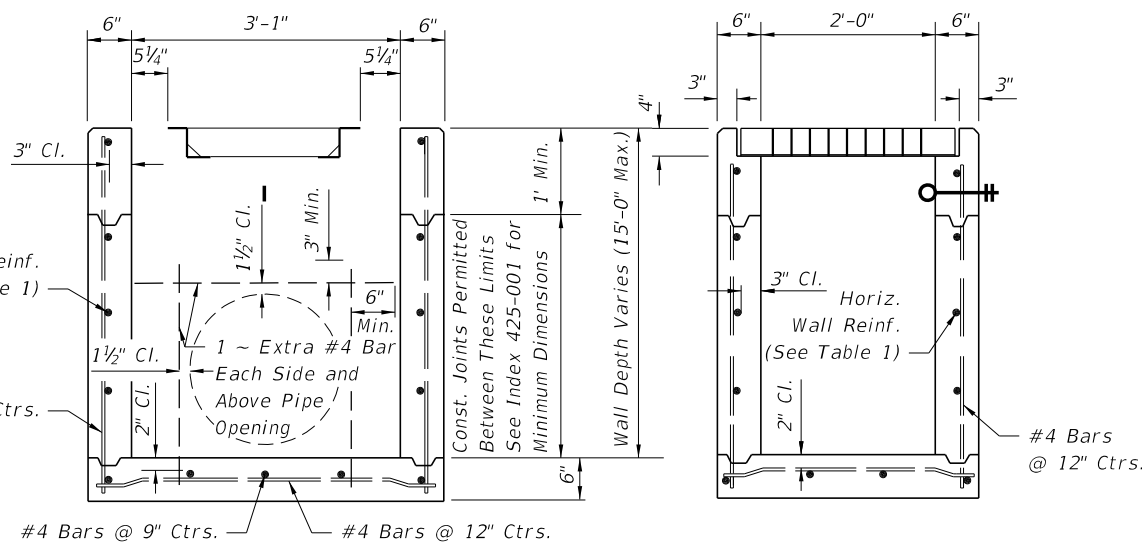

(Pipe Opening Shown) SECTION AA

(Pipe Opening Not Shown) SECTION BB

GENERAL NOTES

- This inlet is designed for ditches, medians, or other area subject to heavy wheel loads on limited access facilities where debris may be a problem. This inlet is not for use in areas subject to pedestrian and/or bicycle traffic.
- All reinforcing is Grade 60 bars with 2" min. cover unless otherwise noted. Cut or bend bars out of way of pipe to clear pipe by 1 1/2". See Index 425-001 for equivalent area of welded wire fabric.
- All exposed edges and corners shall be 3/4" chamfer or tooled to 1/4" radius.
- When alternate "G" grate is specified in plans, the grate is to be hot-dip galvanized after fabrication.
- Cost of ditch paving to be included in the cost of Inlet. Sodding to be paid for under contract unit price for Performance Turf, SY.
- For supplemental details see Index 425-001.
- All dimensions are for both precast and cast-in-place inlets unless otherwise noted.
- Inlet to be paid for under the contract unit price for inlets (Dt Bot Type A), EA.

HORIZONTAL WALL REINFORCING SCHEDULE (TABLE 1)

WALL DEPTH	SCHEDULE	AREA (in. ² /ft.)	MAX. SPACING	
			BARS	WWF
0' - 10'	A12	0.20	12"	8"
10' - 15'	A6	0.20	6"	5"

10/30/2018 8:44:56 AM

LAST REVISION	DESCRIPTION:
11/01/17	



FY 2019-20
STANDARD PLANS

DITCH BOTTOM INLET TYPE A

INDEX
425-050

SHEET
1 of 2

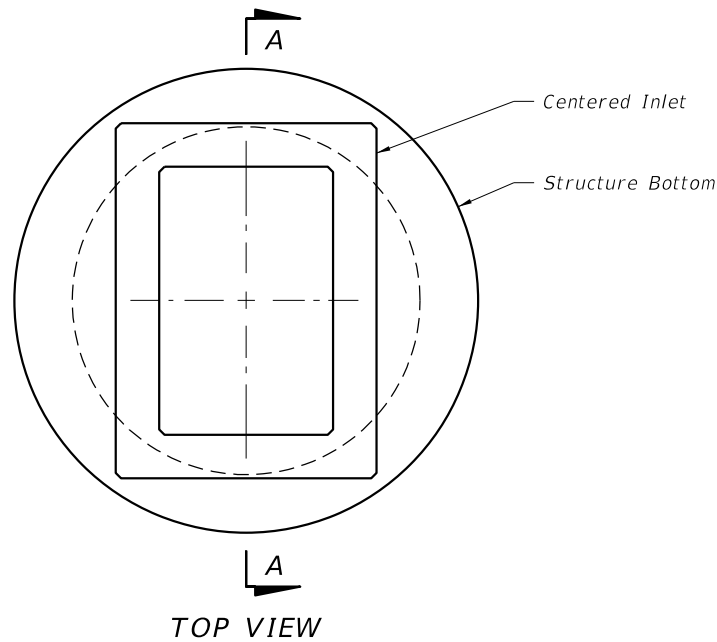

TOP SLAB OPENINGS	
DIAMETER	OPENING SIZE
	MIN.
4'-0" To 8'-0"	2'-0" x 3'-1"

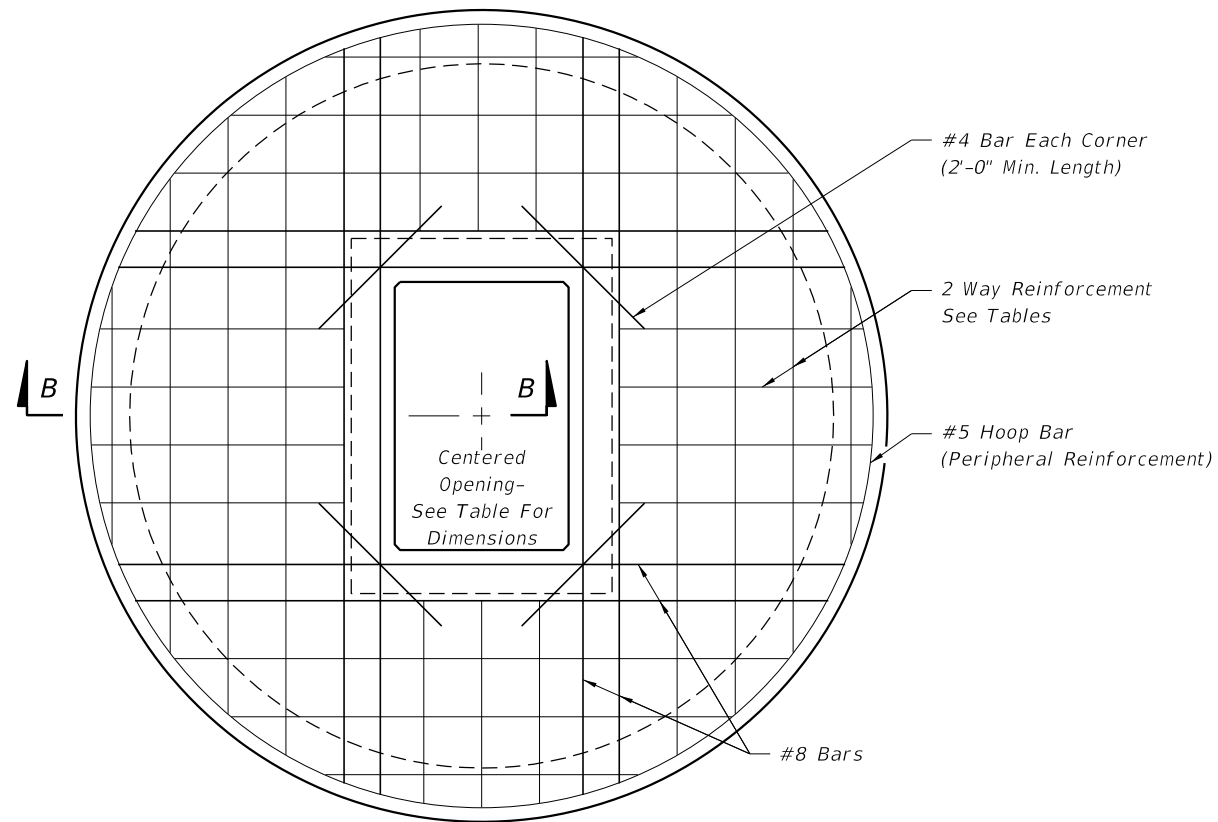
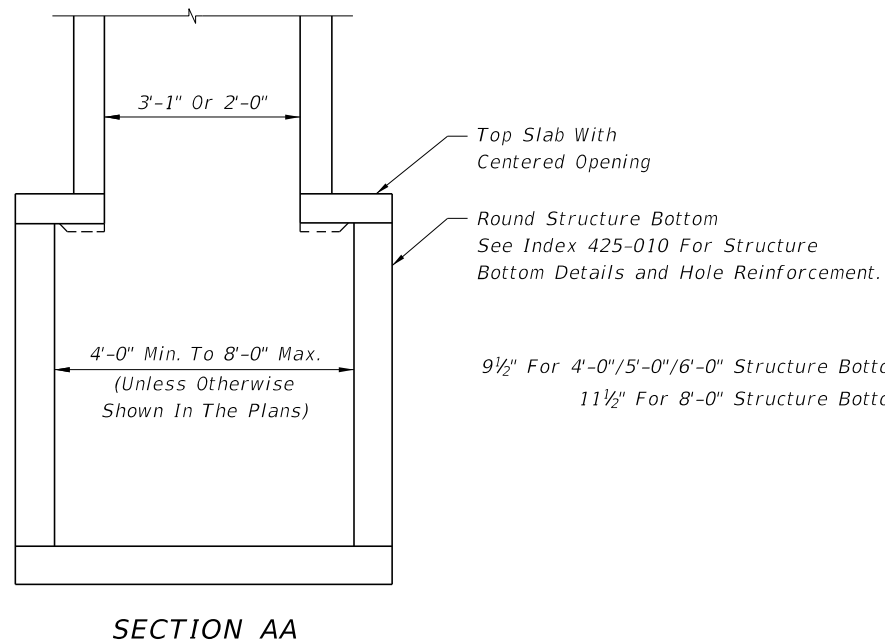

TOP SLAB REINFORCING DIAGRAM

TOP SLAB REINFORCING SCHEDULE	
SCHEDULE	GRADE 60 (BAR) OR 65 KSI & 70 KSI (WIRE FABRIC) In. ² /ft.
A	0.20
B	0.24
C	0.37
D	0.53
E	0.73
F	1.06
G	1.45

TOP SLAB WITH CENTERED OPENING		
SLAB DEPTH	SLAB THICKNESS	REINFORCING (2 WAYS) SCHEDULE
SIZE: 4'-0"		
≥0.5'-40'	9½"	C
SIZE: 5'-0"		
≥0.5'<30'	9½"	C
30'-40'	9½"	D
SIZE: 6'-0"		
0.5'<8'	9½"	B
8'<18'	9½"	C
18'<30'	9½"	D
30'<37'	9½"	E
37'-40'	9½"	G
SIZE: 8'-0"		
≥0.5'<9'	11½"	C
9'<15'	11½"	D
15'<23'	11½"	E
23'<33'	11½"	E
33'-40'	11½"	G

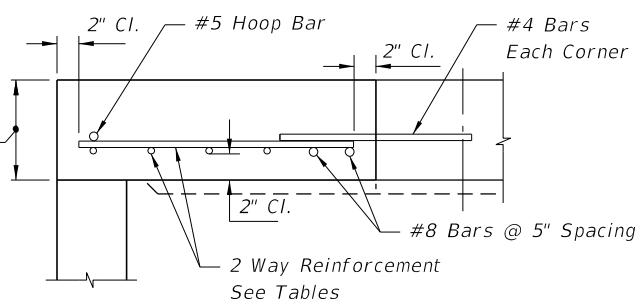

SECTION BB

ALT. A STRUCTURE BOTTOM FOR INLET TYPE A

10/30/2018 8:44:59 AM

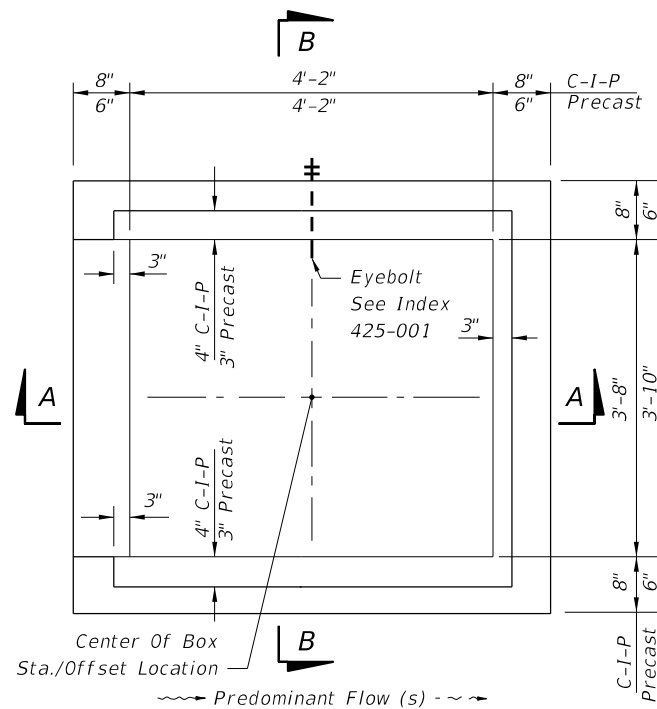

PLAN

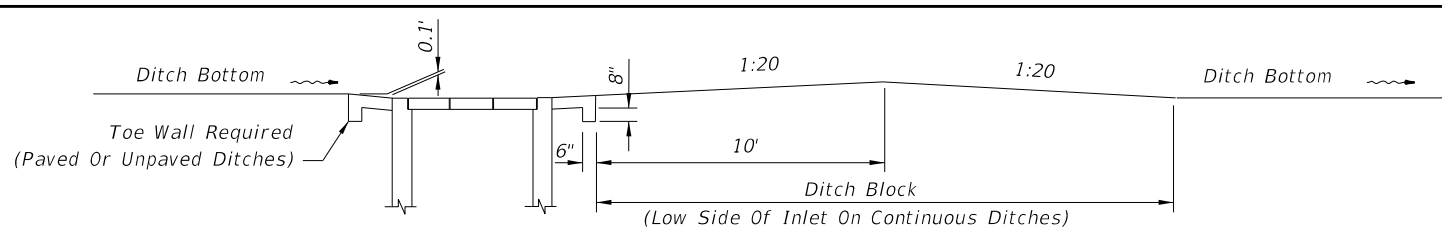

SECTION EE
DITCH BLOCK

ESTIMATED QUANTITIES
For Informational Purposes Only

SLOT TYPE	PAVEMENT		SOD
	SY	CY	SY
Single Slot	6.2	0.9	14
Double Slot	8.1	1.1	19

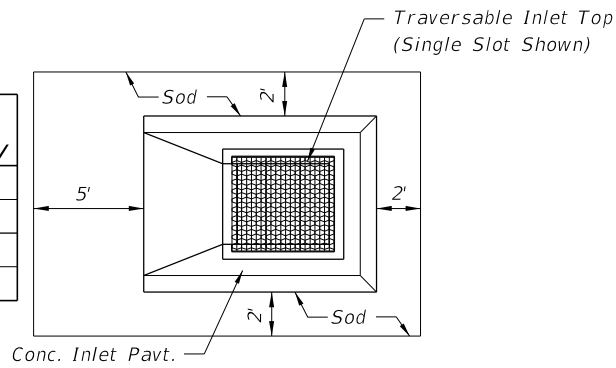

CONCRETE INLET PAVEMENT AND SODDING

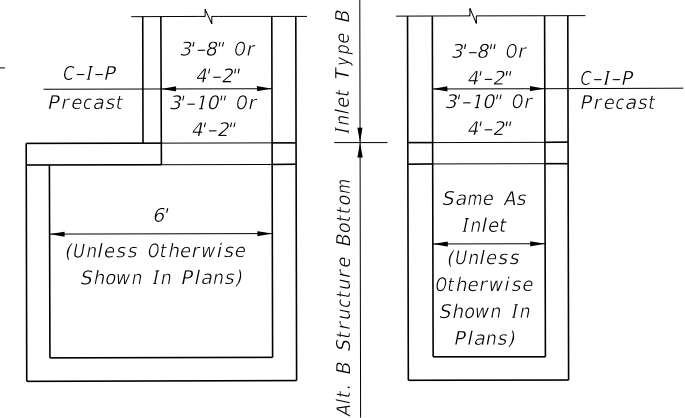

NOTE: Alt. B Structure Bottom Only. See Index 425-010 for structure bottom details and pipe opening reinforcement.
INLET WITH STRUCTURE BOTTOM

RECOMMENDED MAXIMUM PIPE SIZES	
INLET INSIDE WIDTH	PIPE SIZE
3'-8"	30"
4'-2"	36"

Note: Recommended sizes are for concrete pipe. Sizes for other types of pipe must be verified for fit in accordance with Index 425-001. For larger pipe see bottom detail above and Index 425-010.

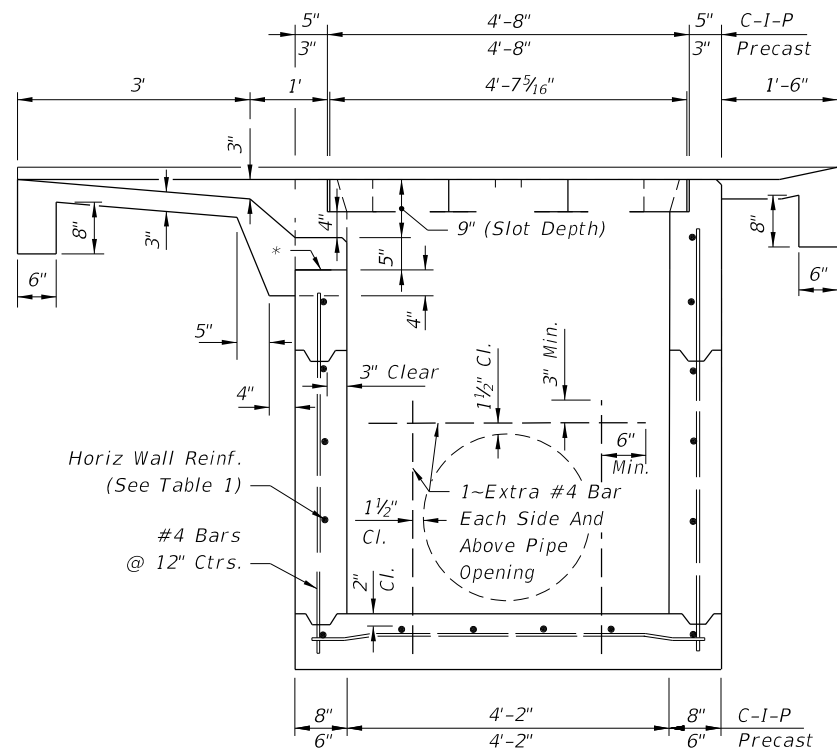

SECTION AA

*See Sheet 2 of 3

HORIZONTAL WALL REINFORCING
SCHEDULE (TABLE 1)

WALL DEPTH	SCHEDULE	AREA (in. ² /ft.)	MAX. SPACING	
			BARS	WWF
0' - 5'	A12	0.20	12"	8"
5' - 9'	A6	0.20	6"	5"
9' - 13'	B5.5	0.24	5 1/2"	5"
13' - 15'	Special	0.267	5"	4"

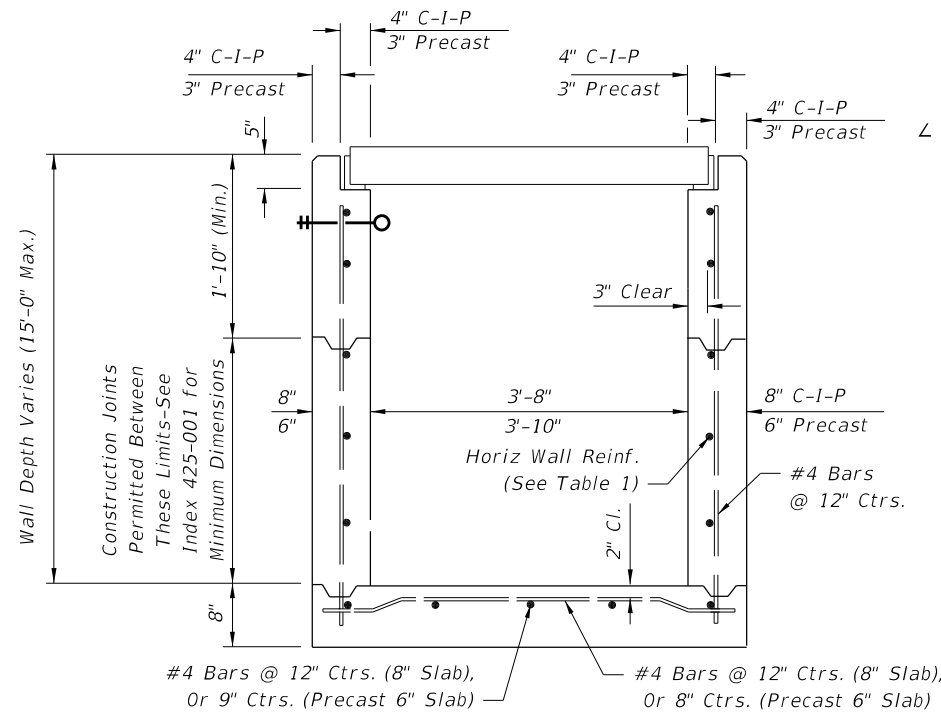

SECTION BB

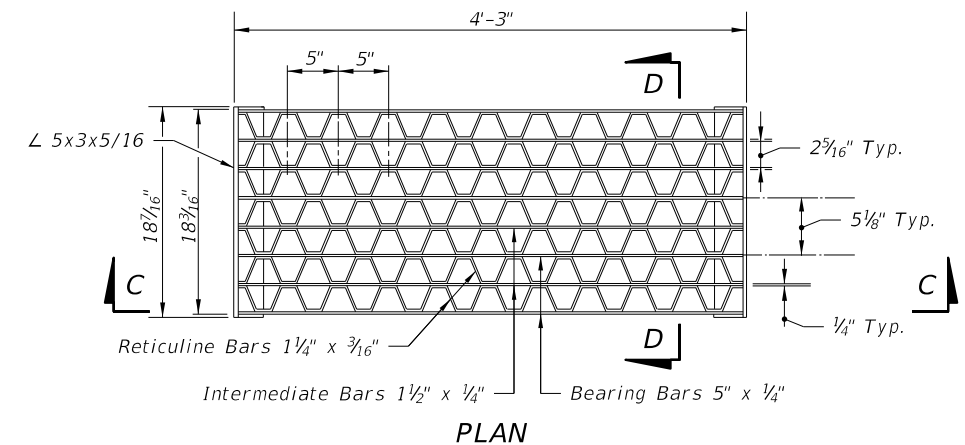

PLAN

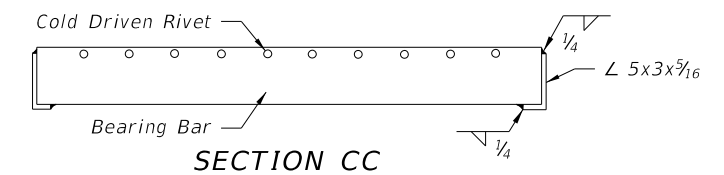

SECTION CC

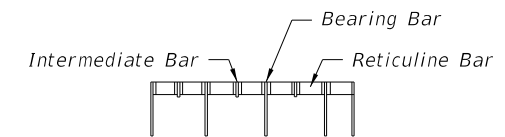

SECTION DD

STEEL GRATE

10/30/2018 8:45:02 AM

LAST REVISION	DESCRIPTION:
11/01/17	



FY 2019-20
STANDARD PLANS

DITCH BOTTOM INLET TYPE B

INDEX
425-051

SHEET
1 of 3

GENERAL NOTES

- The general purpose of the inlet top designs are:
 - For ditches, medians or other areas subject to heavy wheel loads. This inlet may be placed in areas subject to occasional pedestrian traffic such as landscaped areas and pavement areas where pedestrians can walk around the inlet. Inlet not suitable for bicycle traffic.
 - Provide full grate and horizontal slot designs for new construction.
 - Provide full grate and horizontal slot designs for replacing the vertical slot tops on existing Inlets Type B and Type X that are in locations subject to occasional pedestrian traffic.
- All reinforcing is Grade 60 bars with 2" min. cover unless otherwise noted. See Index 425-001 for equivalent area of welded wire fabric. Bars to be cut or bent for min. 1½" clearance around pipe.
- All exposed edges and corners shall be ¾" chamfer or tooled to ¼" radius.
- When Alternate G grates are specified in the plans, the grates are to be hot-dip galvanized after fabrication.
- Cost for constructing traversable tops on new inlet boxes shall be included in the contract unit price for Inlets (DT BOT) (Type B), EA., and shall include the cost for surrounding concrete inlet pavement. Existing Inlets Type B and Inlets Type X that are converted to traversable inlet tops shall be paid for under the contract unit price for Inlets (DT BOT) (Type B) (Partial), EA. Unit price and payment shall be full compensation for inlet conversion and shall include the removal and disposal of any existing concrete inlet pavement; the removal and stockpiling or disposal of sufficient material from the existing inlet box to facilitate construction of the required inlet top; construction of the required inlet conversion; backfill construction; construction of concrete inlet pavement; reusing, supplementing, transferring or replacing grates as required by plans or as directed by the Engineer; any required earthwork for ditch restoration within 30' of the inlet; and, restoration of disturbed turf.
- Ditch pavement shall be paid for, separate from the inlet and concrete inlet pavement, by pavement types and units as called for in the plans.
- Sod will be paid for under the contract unit price for Performance Turf, SY.
- For supplementary details see Index 425-001.
- All dimensions are for both precast and cast-in-place inlets unless otherwise noted.

DESIGN NOTES

- The type of top (single or double slots) depends on the approach ditch configuration and the hydraulic requirements of the site. The designer will stipulate in the plans the type of top to be constructed at each individual inlet location.
- On existing inlets, conversion grates shall be constructed at the original grate elevations unless other elevations are called for in the plans. When plans call for the inlet top to be constructed to support storm water detention, details for ditch modifications and underdrains shall be shown in the plans.

MAINTENANCE NOTES

- Traversable inlet tops that are constructed by maintenance contract or by maintenance forces may reuse the existing grates that are determined by the Maintenance Engineer to be functionally sound, and their reuse is so directed by the Maintenance Engineer. Existing grates approved for reuse and new grates may be mixed, matched or replaced as directed by the Maintenance Engineer.

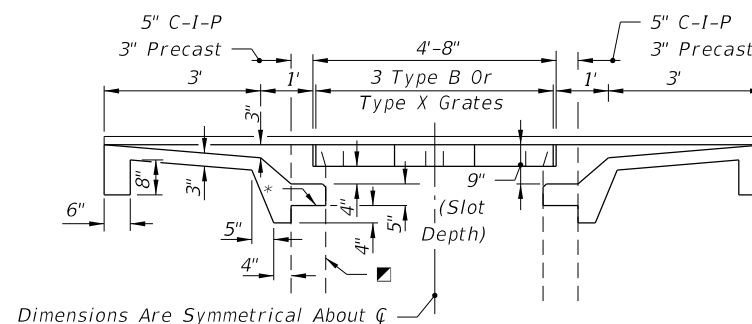
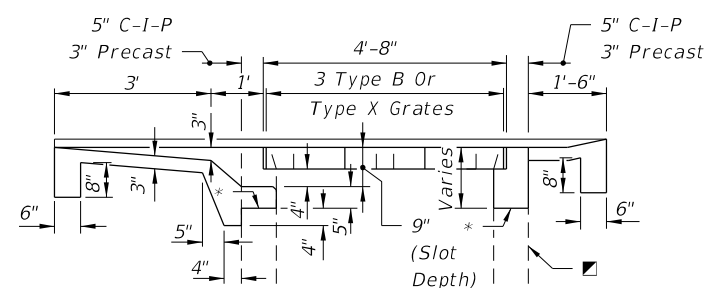
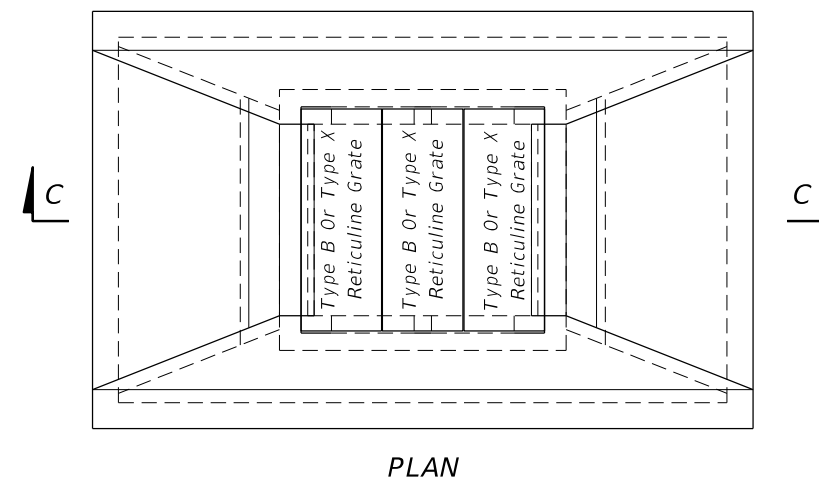
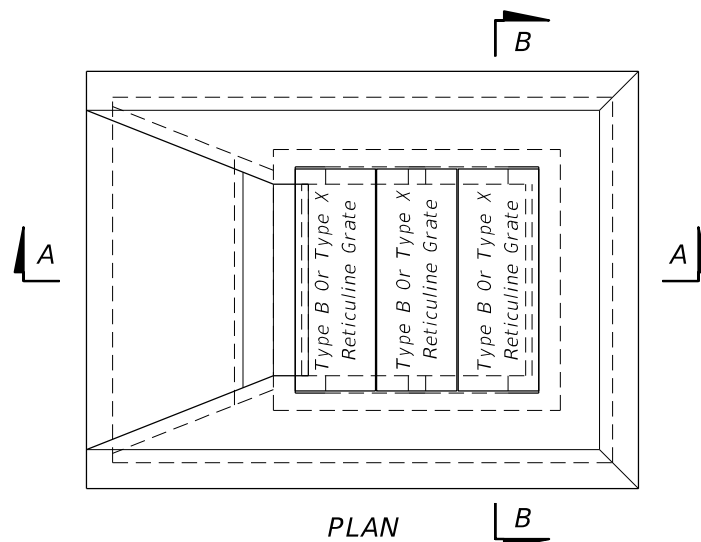
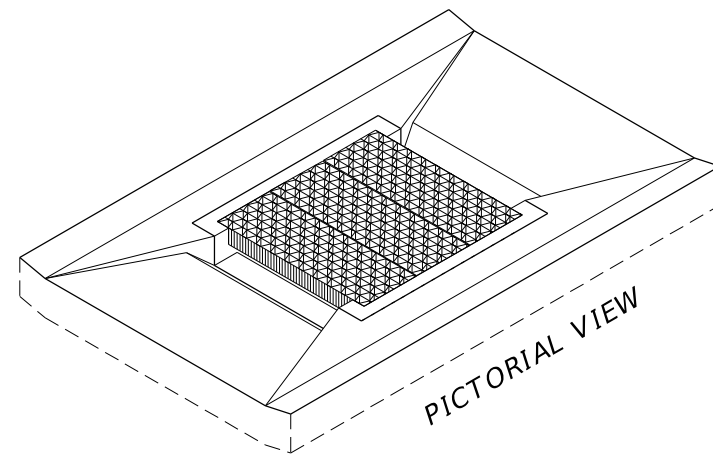
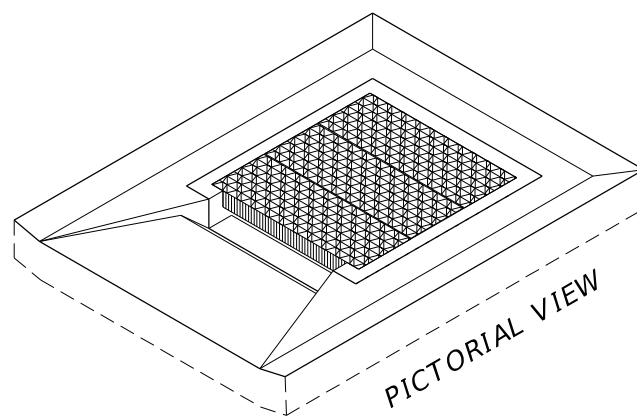

**SECTION AA
SINGLE SLOT**

**SECTION CC
DOUBLE SLOT**

■ Inlet Box (Line Type Indicates Existing Box To Facilitate Depiction Of Partial Construction On Existing Inlets)

* On new boxes the traversable top may be cast as a monolithic unit or cast in segments, and the location of this line may be lower to facilitate handling and placement; however, the slot depth is to remain at 9 inches. See Index 425-001 for top to wall connection. For converting to traversable tops on existing inlets remove concrete to this line and expose the existing reinforcement. Reshape or splice in reinforcement to penetrate the rim and returns of the grate seat, and bend the reinforcement into the slot shelf to extend into the abutting throat pavement.

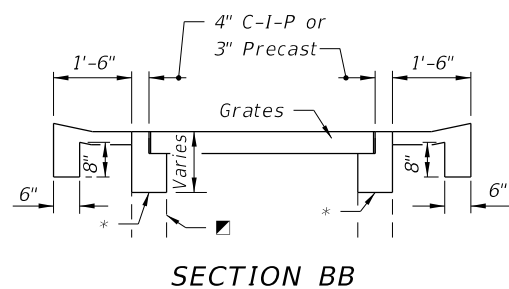

SECTION BB

**TRAVERSABLE TOPS FOR INLETS TYPE B AND
FOR CONVERSIONS OF EXISTING INLETS TYPE B AND TYPE X**

10/30/2018 8:45:07 AM

LAST REVISION 11/01/17	REVISION	DESCRIPTION:		FY 2019-20 STANDARD PLANS	DITCH BOTTOM INLET TYPE B	INDEX 425-051	SHEET 2 of 3
---------------------------	----------	--------------	--	------------------------------	---------------------------	------------------	-----------------

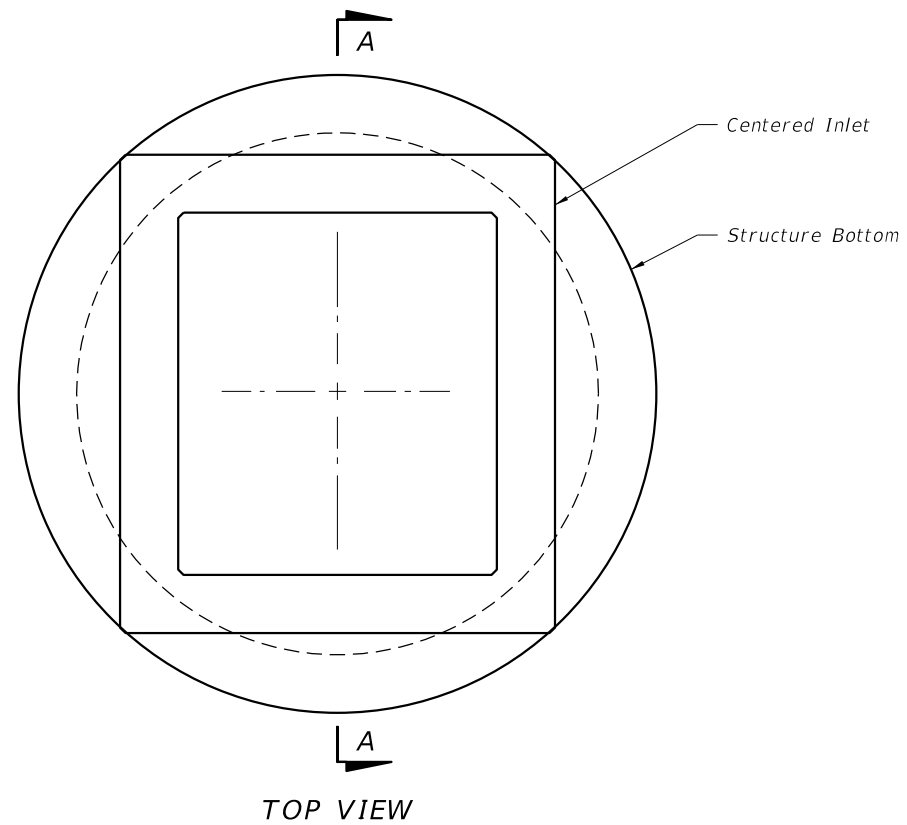

TOP VIEW

TOP SLAB OPENINGS		
DIAMETER	OPENING SIZE	
	MIN.	MAX.
6'-0" to 8'-0"	3'-8" x 4'-2"	3'-10" x 4'-2"

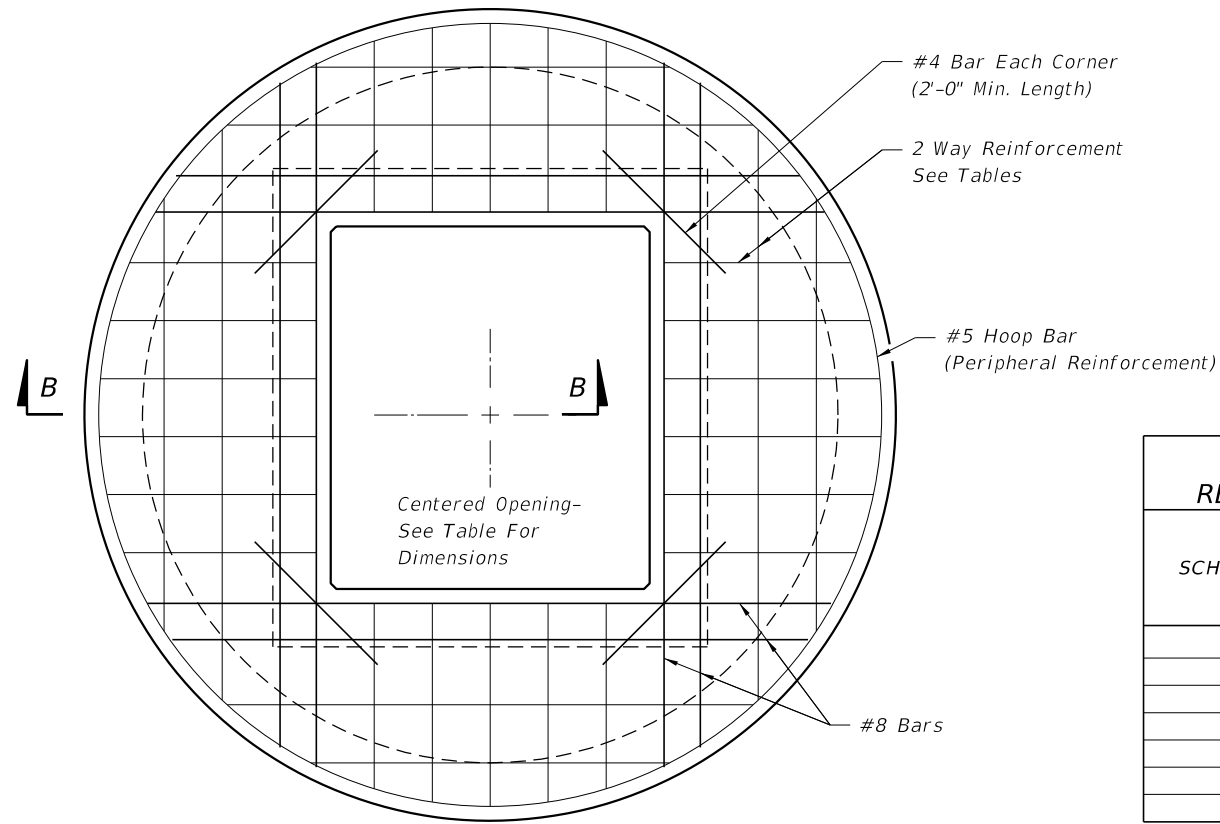

TOP SLAB REINFORCING DIAGRAM

TOP SLAB REINFORCING SCHEDULE	
SCHEDULE	GRADE 60 (BAR) OR 65 KSI & 70 KSI (WIRE FABRIC) In ² /ft.
A	0.20
B	0.24
C	0.37
D	0.53
E	0.73
F	1.06
G	1.45

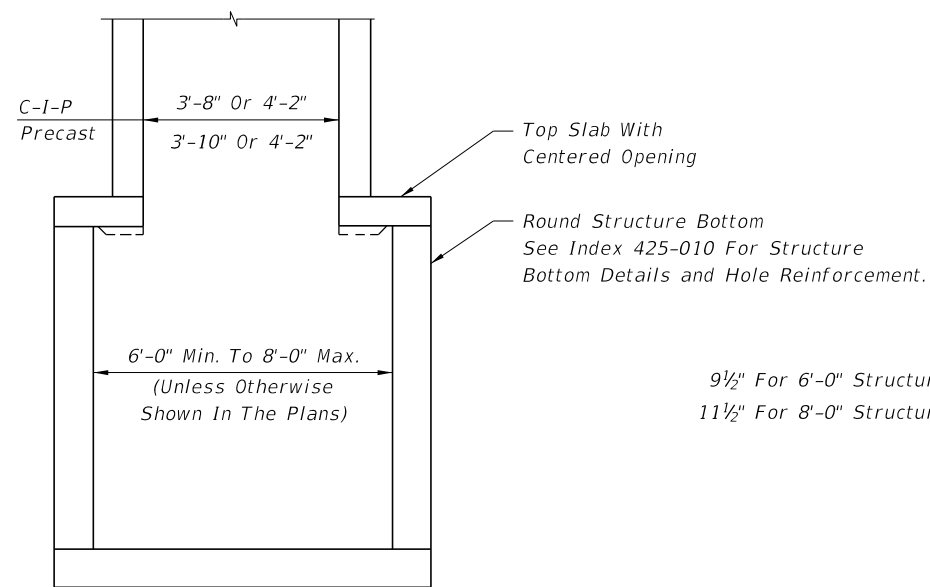

SECTION AA

9½" For 6'-0" Structure Bottoms
11½" For 8'-0" Structure Bottoms

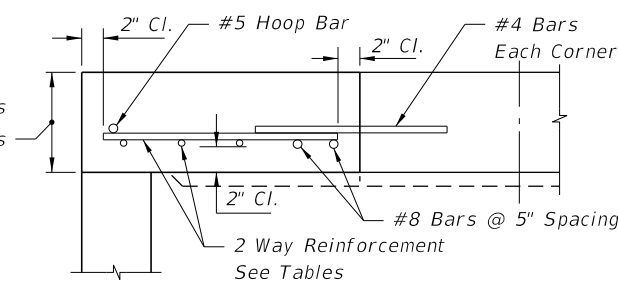

SECTION BB

TOP SLAB WITH CENTERED OPENING		
SLAB DEPTH	SLAB THICKNESS	REINFORCING (2 WAYS) SCHEDULE
SIZE: 6'-0"		
0.5' < 8'	9½"	B
8' < 18"	9½"	C
18' < 30'	9½"	D
30' < 37'	9½"	E
37'-40'	9½"	G
SIZE: 8'-0"		
≥0.5' < 9'	11½"	C
9' < 15'	11½"	D
15' < 23'	11½"	E
23' < 33'	11½"	E
33'-40'	11½"	G

ALT. A STRUCTURE BOTTOM FOR INLET TYPE B

10/30/2018 8:45:10 AM

LAST REVISION 11/01/17	DESCRIPTION:
---------------------------	--------------



FY 2019-20
STANDARD PLANS

DITCH BOTTOM INLET TYPE B

INDEX
425-051

SHEET
3 of 3

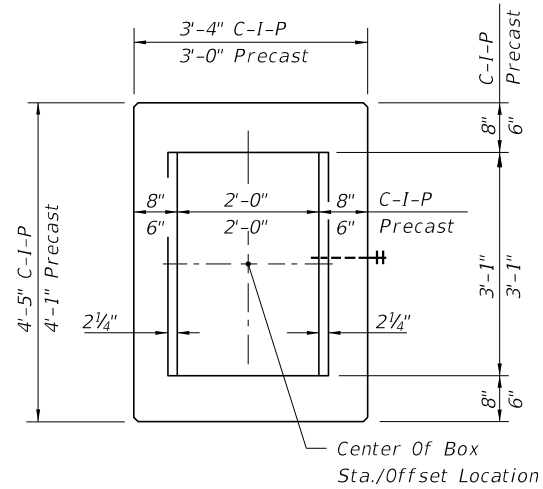

PLAN

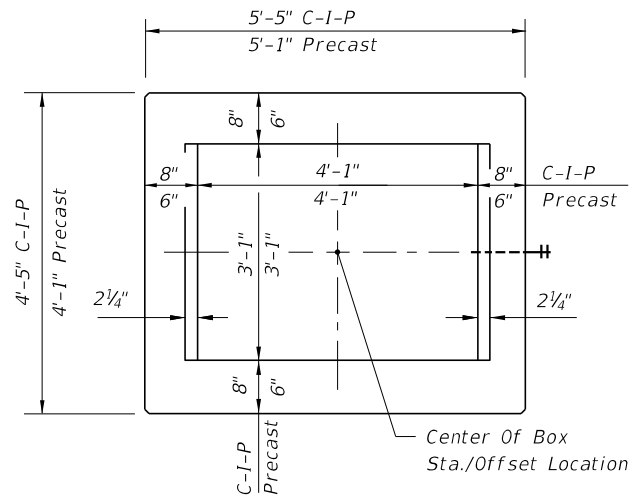

PLAN

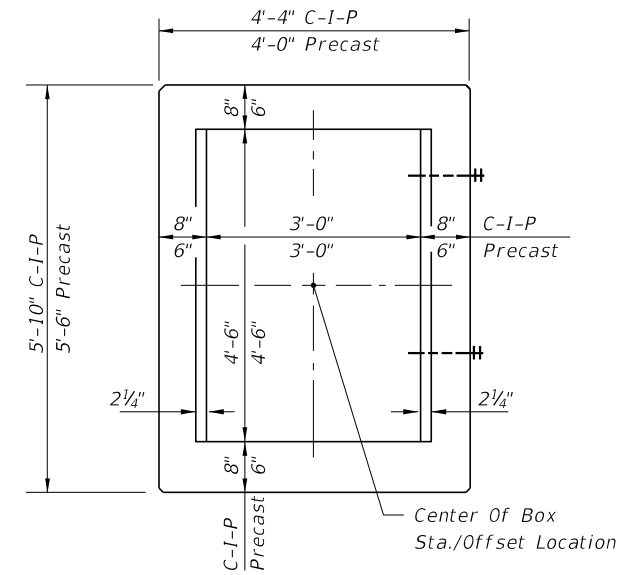

PLAN

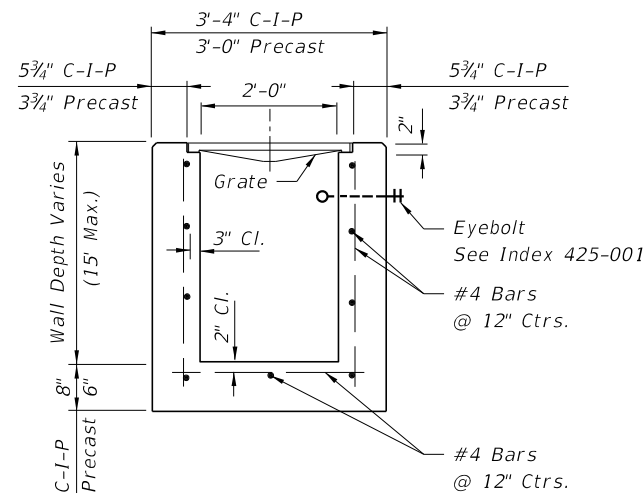

SECTION

HORIZONTAL WALL REINFORCING SCHEDULES (TABLE 1)

WALL DEPTH	SCHEDULE	AREA (in. ² /ft.)	MAX. SPACING	
			BARS	WWF
0'-15'	A12	0.20	12"	8"

TYPE C

Recommended Maximum Pipe Size:

- 2'-0" Wall - 18" Pipe
- 3'-1" Wall - 24" Pipe (18" where an 18" pipe enters a 2'-0" wall)

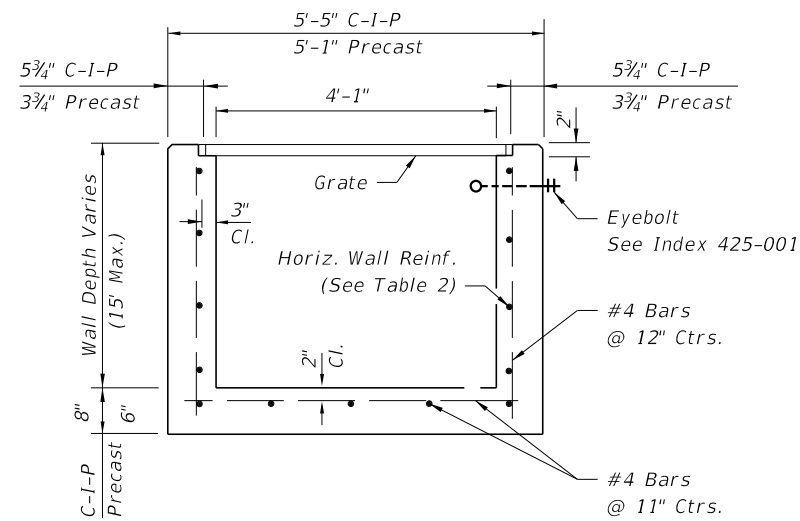

SECTION

HORIZONTAL WALL REINFORCING SCHEDULES (TABLE 2)

WALL DEPTH	SCHEDULE	AREA (in. ² /ft.)	MAX. SPACING	
			BARS	WWF
0'-6'	A12	0.20	12"	8"
6'-10'	A6	0.20	6"	5"
10'-13'	A4	0.20	4"	3"
10'-15'	B5.5	0.24	5½"	5"

TYPE D

Recommended Maximum Pipe Size:

- 3'-1" Wall - 24" Pipe
- 4'-1" Wall - 36" Pipe

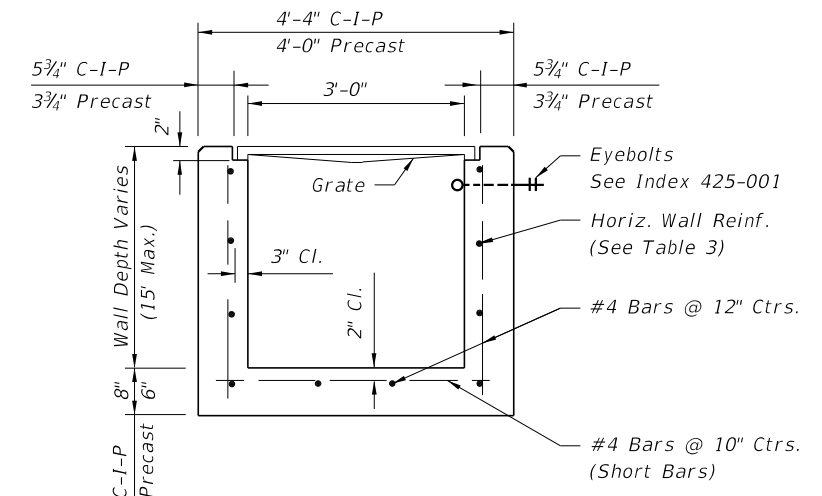

SECTION

HORIZONTAL WALL REINFORCING SCHEDULES (TABLE 3)

WALL DEPTH	SCHEDULE	AREA (in. ² /ft.)	MAX. SPACING	
			BARS	WWF
0'-5'	A12	0.20	12"	8"
0'-7.5'	A6	0.20	6"	5"
7.5'-10'	B5.5	0.24	5½"	5"
10'-15'	C6.5	0.37	6½"	6"

TYPE E

Recommended Maximum Pipe Size:

- 3'-0" Wall - 24" Pipe
- 4'-6" Wall - 36" Pipe

10/30/2018 8:45:14 AM

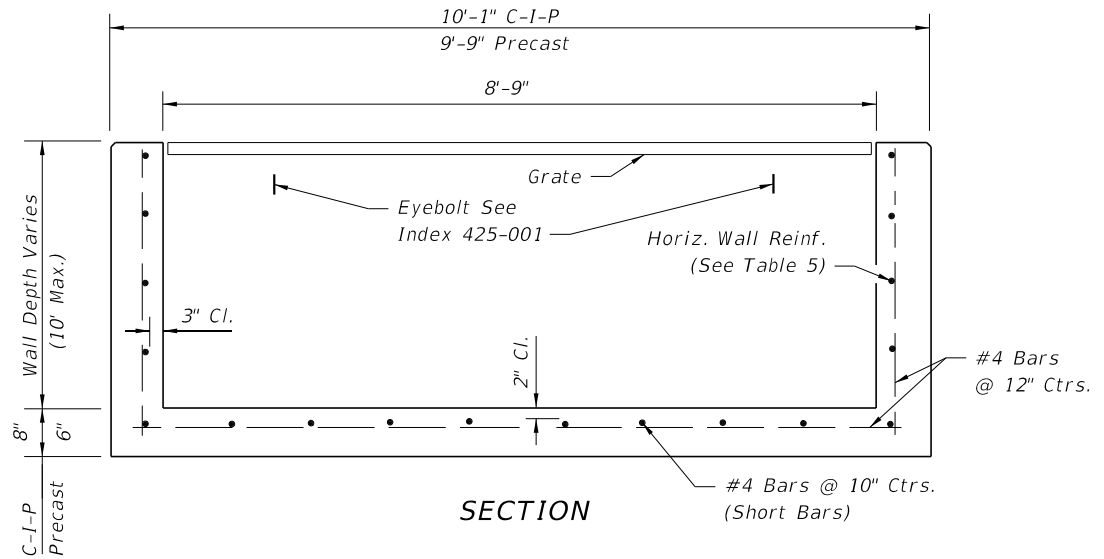
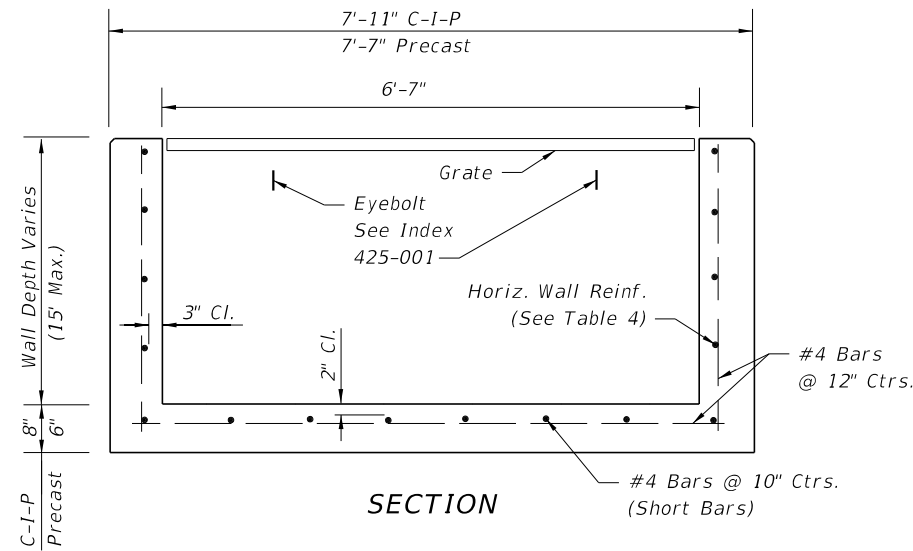
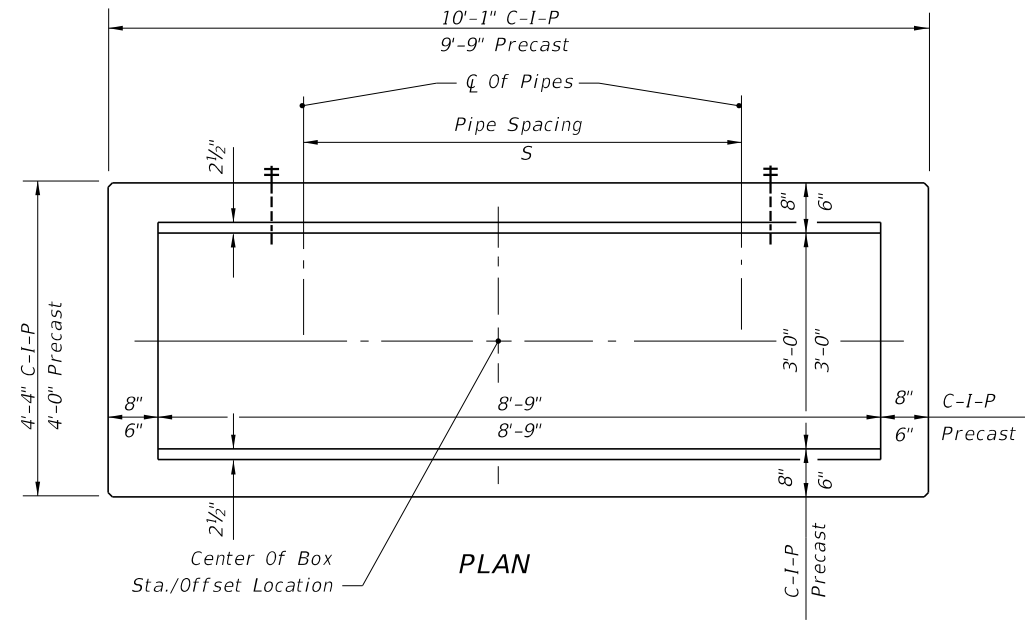
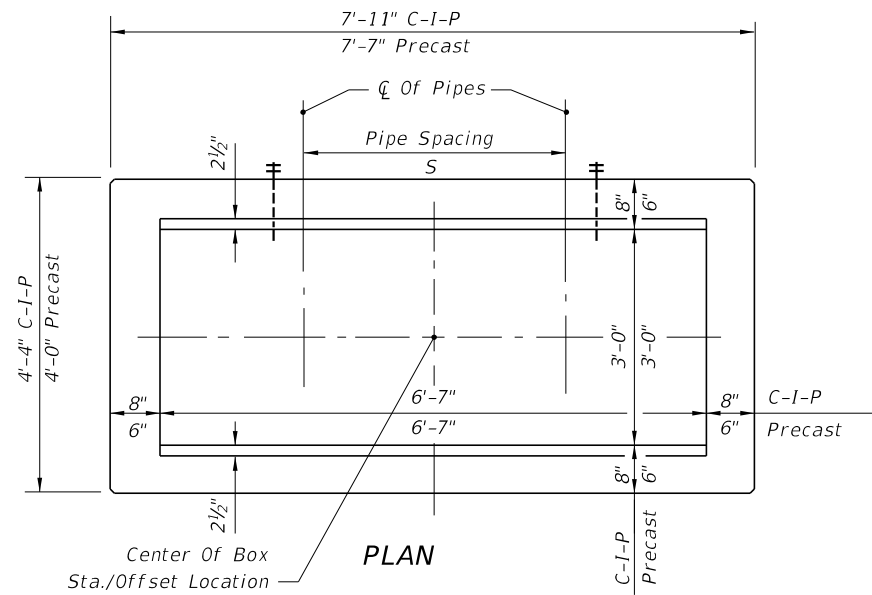

HORIZONTAL WALL REINFORCING SCHEDULES (TABLE 4)

WALL DEPTH	SCHEDULE	AREA (in. ² /ft.)	MAX. SPACING	
			BARS	WWF
0'-5'	B5.5	0.24	5½"	5"
5'-7'	C6.5	0.37	6½"	6"
7'-15'	D4.5	0.53	4½"	4"

HORIZONTAL WALL REINFORCING SCHEDULES (TABLE 5)

WALL DEPTH	SCHEDULE	AREA (in. ² /ft.)	MAX. SPACING	
			BARS	WWF
0'-5'	C3.5	0.37	3½"	3"
5'-10'	D4.5	0.53	4½"	4"

TYPE H (2 & 3-GRATE INLET)

Recommended Maximum Pipe Size:
 3'-0" Wall - 24" Pipe
 6'-7" Wall - 1-60" Pipe
 Or 2-24" Pipe (S=3'-5")

TYPE H (4-GRATE INLET)

Recommended Maximum Pipe Size:
 3'-0" Wall - 24" Pipe
 8'-9" Wall - 1-78" Pipe
 Or 2-30" Pipe (S=4'-3")

GENERAL NOTES
 See Sheet 3 of 7.

10/30/2018 8:45:18 AM

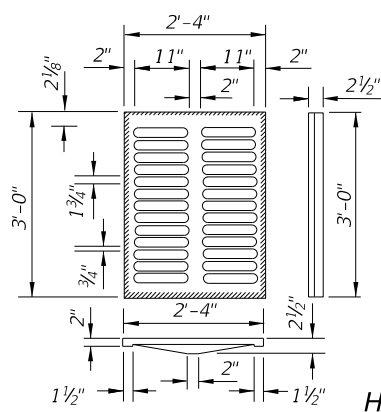

HALF SECTION CAST IRON GRATES

TYPE C
Approx. Weight 235 Lbs.

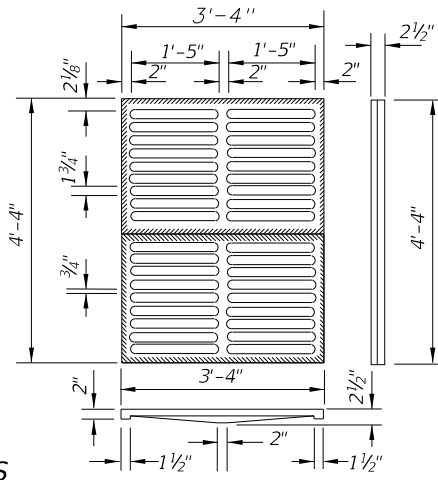

TYPE E
Approx. Weight 465 Lbs.

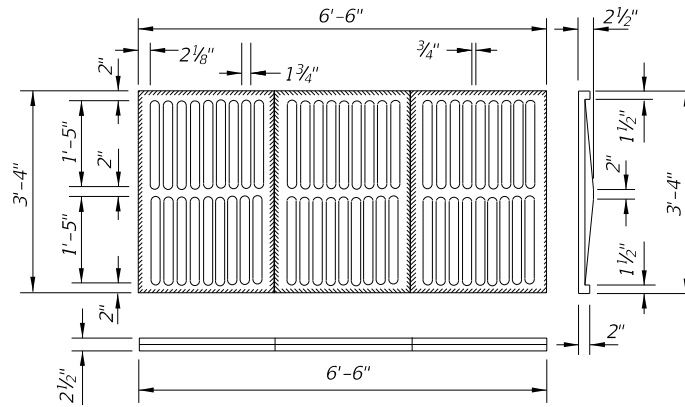

TYPE H (3-GRATE INLET)
Approx. Weight 725 Lbs.

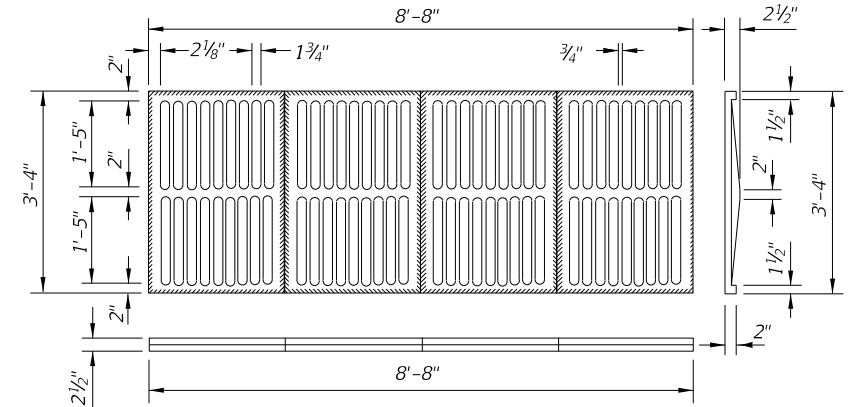

TYPE H (4-GRATE INLET)
Approx. Weight 967 Lbs.

CAST IRON GRATES

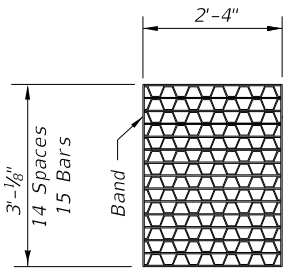

TYPE C

Straight Bars 2" x 1/4"
Reticuline Bars 1 1/4" x 3/16"
Bands 2" x 1/4"
Approx. Weight 104 Lbs.

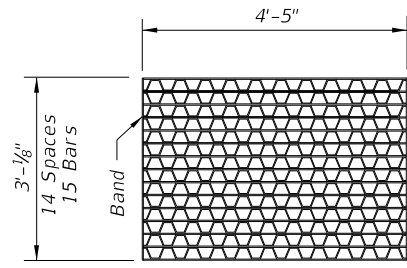

TYPE D

Straight Bars 2" x 1/4"
Reticuline Bars 1 1/4" x 3/16"
Bands 2" x 1/4"
Approx. Weight 190 Lbs.

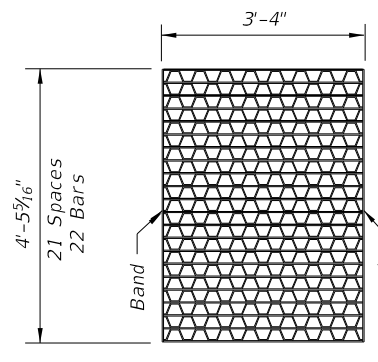

TYPE E

Straight Bars 2" x 1/4"
Reticuline Bars 1 1/4" x 3/16"
Bands 2" x 1/4"
Approx. Weight 215 Lbs.

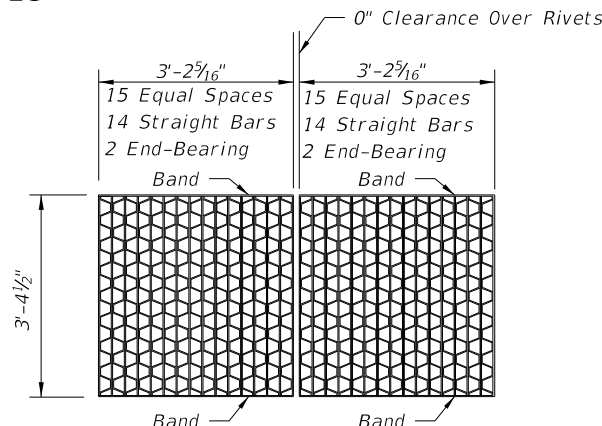

TYPE H (2-GRATE INLET)

Straight End-Bearing Bars 2" x 3/8" Banding Bars 2" x 1/4"
Straight Bearing Bars 2" x 1/4" Approx. Total Weight 310 Lbs.
Reticuline Bars 1 1/4" x 3/16"

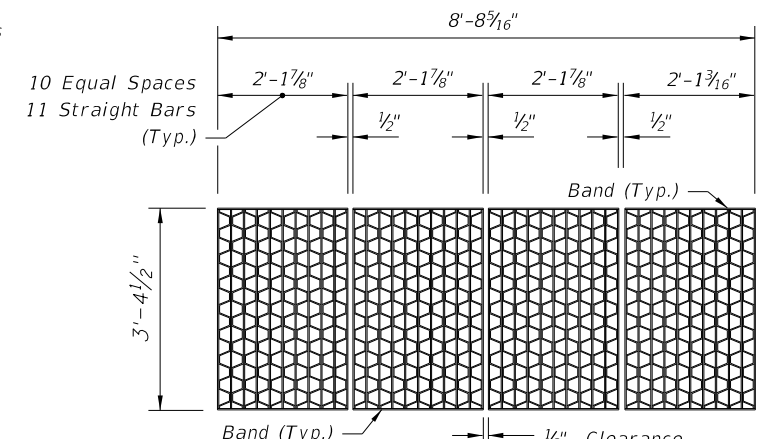

TYPE H (4-GRATE INLET)

Straight End-Bearing Bars 2" x 1/4"
Reticuline Bars 1 1/4" x 3/16"
Banding Bars 2" x 3/16"
Approx. Total Weight 388 Lbs.

STEEL GRATES

NOTE: Steel Grates Are Required On Inlets With Traversable Slots And On Inlets where Bicycle Traffic Is Anticipated.

GENERAL NOTES

- These inlets are suitable for bicycle traffic and are to be used in ditches, medians and other areas subject to infrequent traffic loadings but are not to be placed in areas subject to any heavy wheel loads. These inlets may be placed in areas subject to occasional pedestrian traffic such as landscaped areas and pavement areas where pedestrians can walk around the inlet.
- Inlets subject to minimal debris should be constructed without slots. Where debris is a problem inlets should be constructed with slots. Slotted inlets located within roadway clear zones and areas subject to pedestrians shall have traversable slots. The traversable slot modification is not adaptable to inlet Type H. Slots may be constructed at either or both ends as shown on plans. Traversable slots shall not be used in areas subject to occasional bicycle traffic.
- Steel grates are to be used on all inlets where bicycle traffic is anticipated. Steel grates are to be used on all inlets with traversable slots. Either cast iron or steel grates may be used on inlets without slots where bicycle traffic is not anticipated. Either cast iron or steel grates may be used on all inlets with non-traversable slots. Subject to the selection described above, when Alternate G grate is specified in the plans, either the steel grate, hot dip galvanized after fabrication, or the cast iron grate may be used, unless the plans stipulate the particular type.
- Recommended maximum pipe sizes shown are for concrete pipe. Size for other types of pipe must be checked for fit.
- All exposed edges and corners shall be 3/4" chamfer or tooled to 1/4" radius.
- Concrete inlet pavement to be used on inlets without slots and inlets with non-traversable slots only when called for in the plans; but required on all traversable slot inlets. Cost to be included in contract unit price for inlets. Quantities shown are for information only.
- Traversable slots constructed in existing inlets shall be paid for as inlets partial. For conversion work and method of payment see 'TRAVERSABLE SLOT INLETS (PARTIAL) FOR EXISTING INLETS'.
- Sodding to be used on all inlets not located in paved areas and paid for under contract unit price for Performance Turf, SY.
- For supplementary details see Index 425-001.
- All reinforcing is Grade 60 bars with 2" min. cover unless otherwise noted. Bars to be cut or bent for 1 1/2" clearance around pipe opening. Provide one additional #4 bar above and at each side of pipe opening.

10/30/2018 8:45:22 AM

LAST REVISION 11/01/17	DESCRIPTION:	 FY 2019-20 STANDARD PLANS	DITCH BOTTOM INLET TYPES C, D, E AND H	INDEX 425-052	SHEET 3 of 7
---------------------------	--------------	-----------------------------------------------------------------------------------------------------------------------	-----------------------------------------------	------------------	-----------------

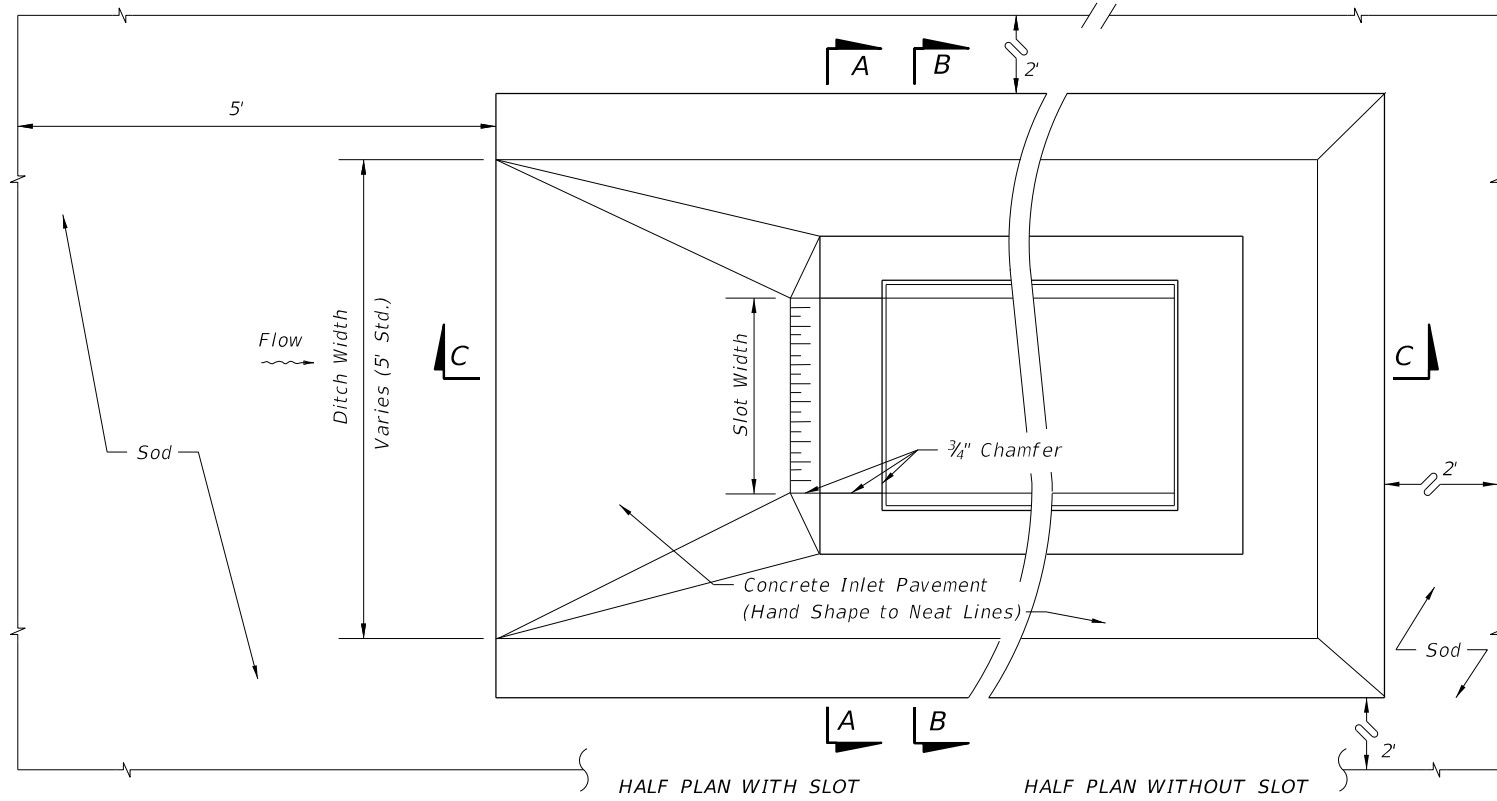

PLAN VIEW

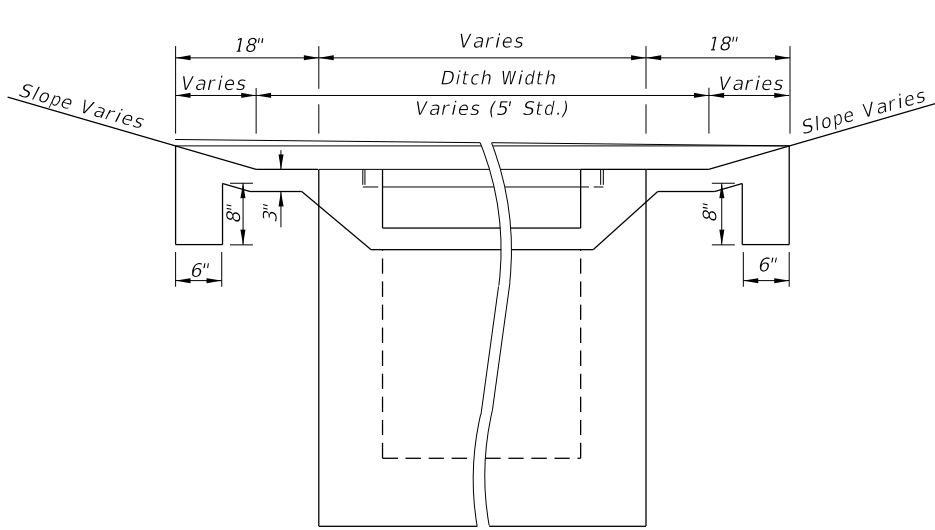

SECTION AA

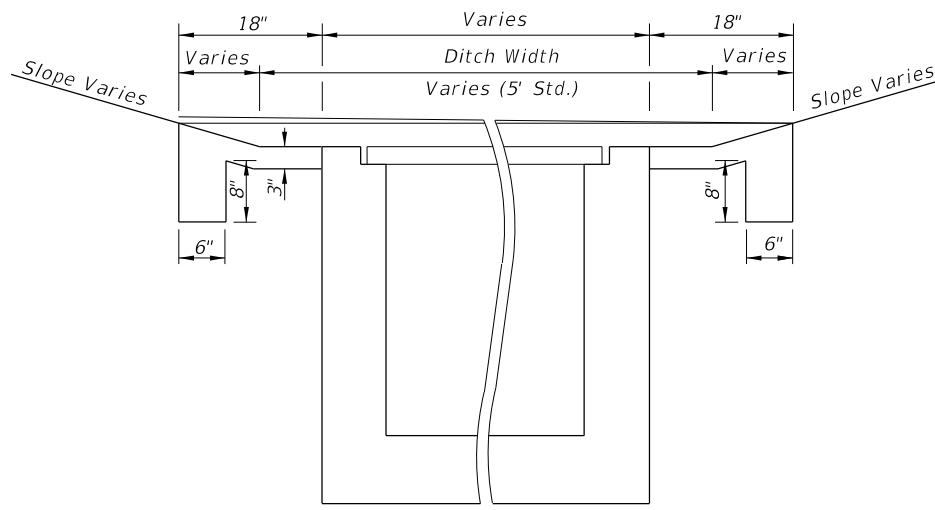

SECTION BB

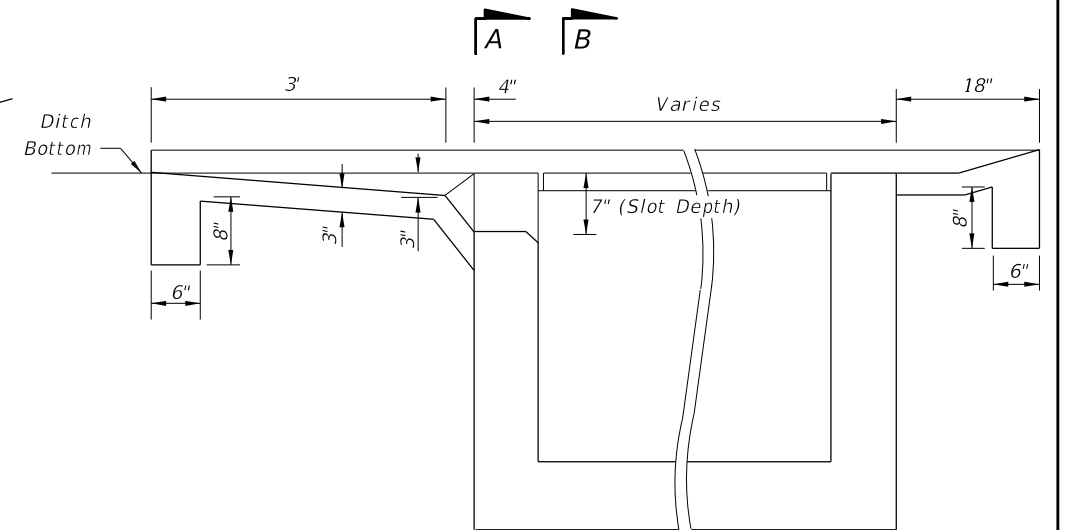

SECTION CC

PAVEMENT AND SODDING QUANTITIES FOR TRAVERSABLE SLOTS						
Inlet	Pavement				Sod	
	Single Slot		Double Slot		Single Slot	Double Slot
	SY	CY	SY	CY	SY	SY
C	4.87	0.77	6.16	0.93	12	16
D	5.99	0.91	7.70	1.10	14	19
E	5.88	0.91	7.37	1.08	14	18

TRAVERSABLE SLOTS

10/30/2018 8:45:26 AM

LAST REVISION	DESCRIPTION:
11/01/17	



FY 2019-20
STANDARD PLANS

DITCH BOTTOM INLET TYPES C, D, E AND H

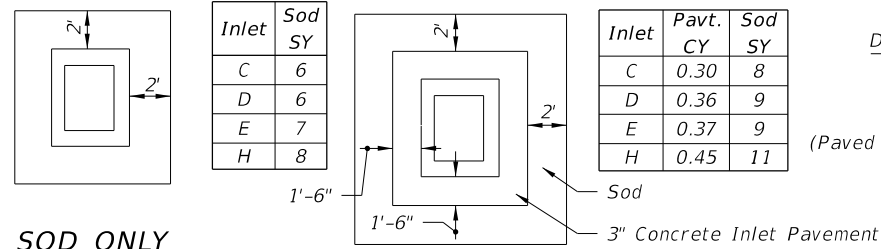
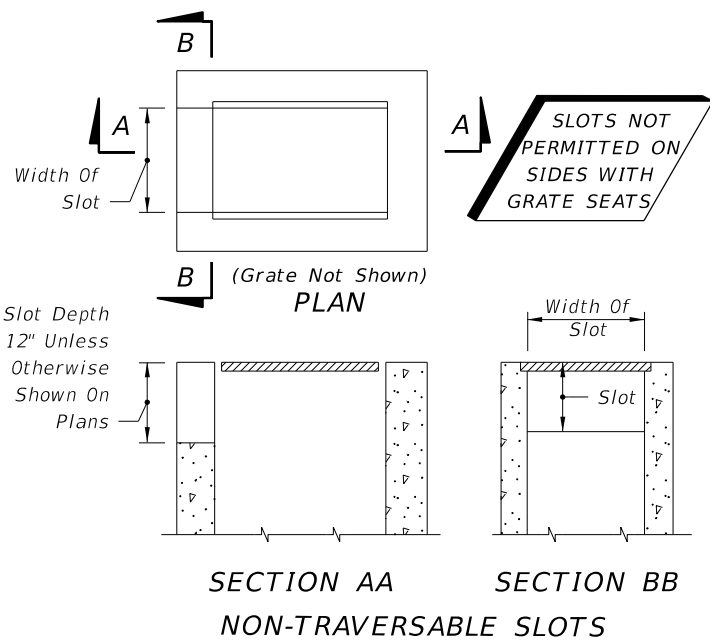
INDEX	SHEET
425-052	4 of 7

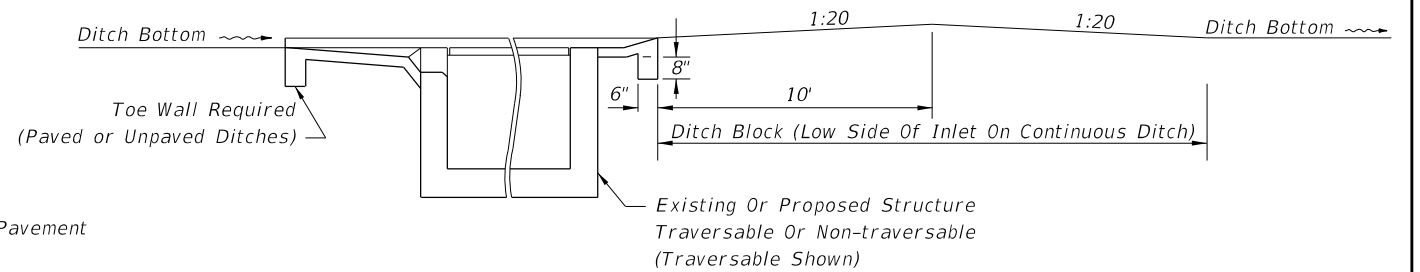

NOTE: See General Notes Nos. 6 and 7, Sheet 3 of 7.
SODDING AND PAVEMENT FOR INLETS WITHOUT SLOTS AND INLETS WITH NON-TRAVERSABLE SLOTS



DITCH BLOCK FOR INLETS WITH OR WITHOUT SLOTS

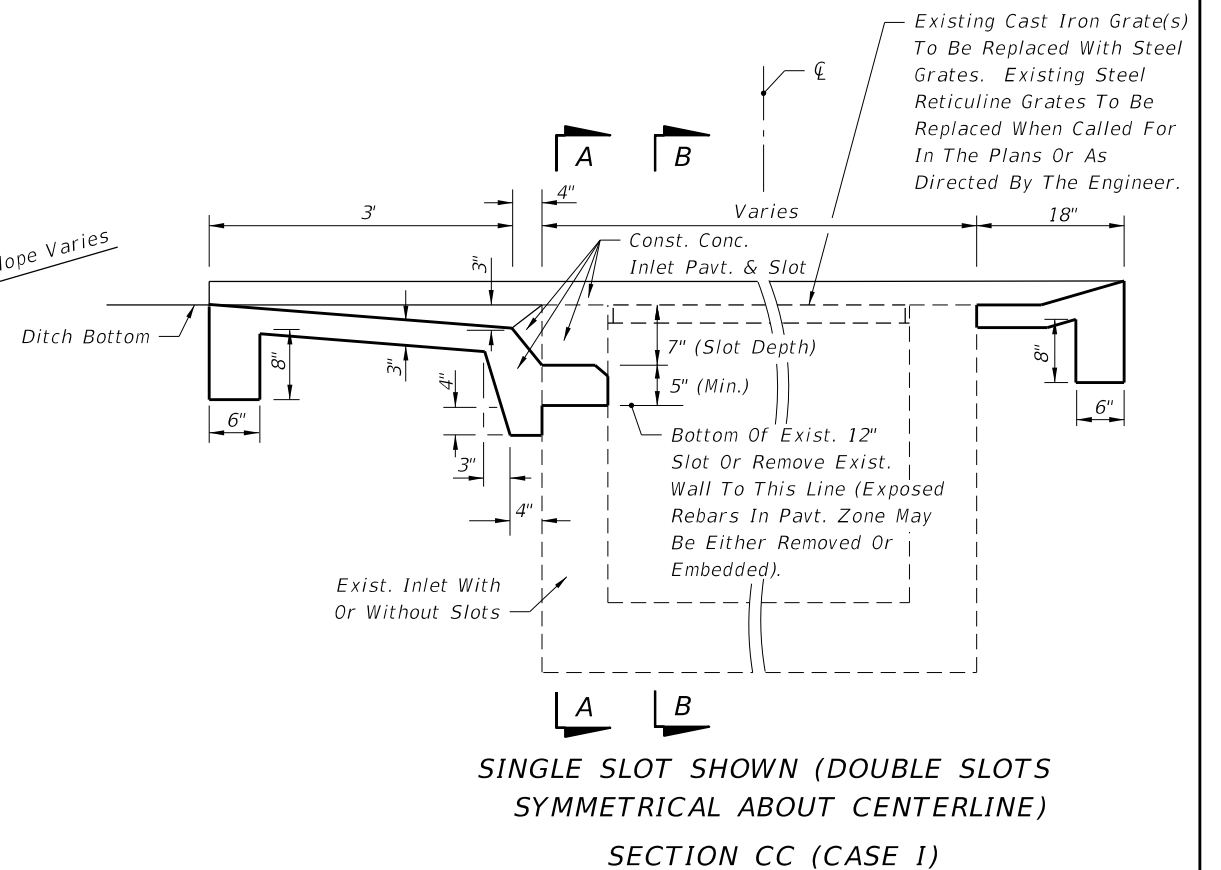
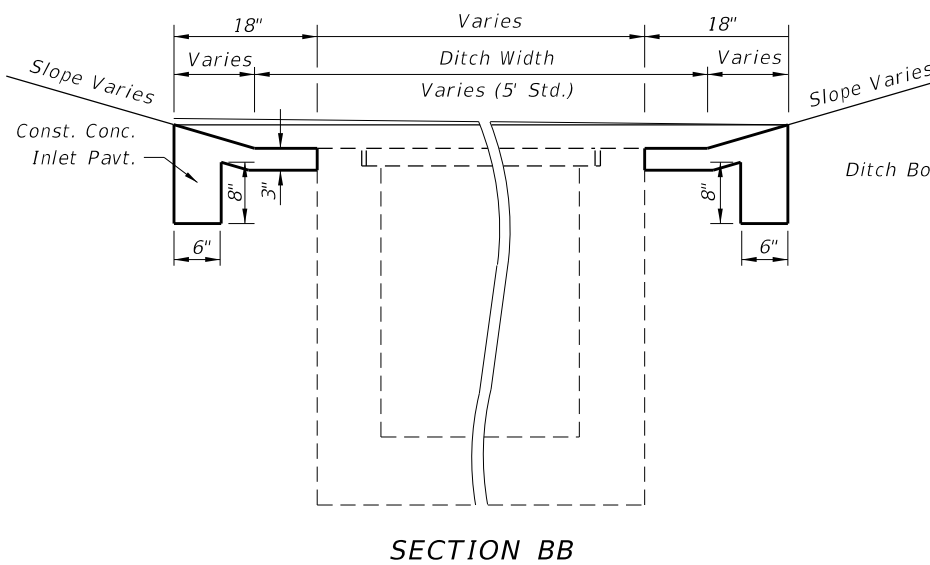
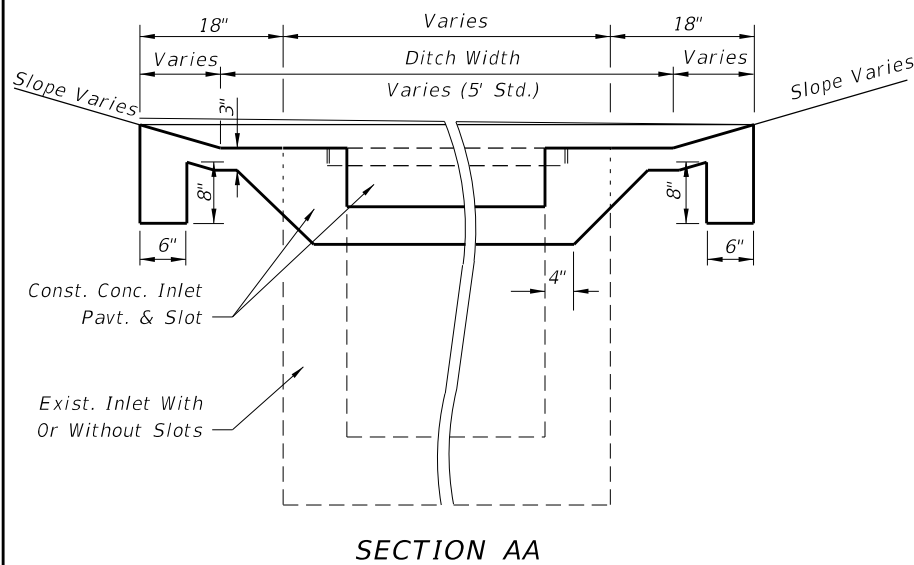

PAVEMENT AND SODDING QUANTITIES FOR TRAVERSABLE SLOTS

Inlet	Pavement		Sod	
	Single Slot SY	Double Slot CY	Single Slot SY	Double Slot SY
C	4.87	0.83	6.16	1.05
D	5.99	1.01	7.70	1.30
E	5.88	0.99	7.37	1.24

NOTE: For plan view and additional details see Sheet 4 of 7.
 For payment see General Notes Nos. 6 and 7, Sheet 3 of 7.
TRAVERSABLE SLOTS FOR EXISTING INLETS

10/30/2018 8:45:29 AM

LAST REVISION	DESCRIPTION:
11/01/17	



FY 2019-20
STANDARD PLANS

DITCH BOTTOM INLET TYPES C, D, E AND H

INDEX
425-052

SHEET
5 of 7

DESIGN NOTES FOR TRAVERSABLE SLOT INLETS (PARTIAL) FOR EXISTING INLETS

1. The general purpose of these conversions is to remove the hazard of the protruding inlet top, while not creating a hazard by depressing the top too deeply.
2. The corrective procedure depends on the approach ditch grade and hydraulic requirements of the site. The selection of the appropriate case depends on the relationship between inlet top and ditch elevation, and, on the vertical clearance between the top of the uppermost pipe(s) and the grate. The purpose for the Case 1 conversion is to add the traversable slot to an existing inlet where top removal, change in grate elevation and ditch transitions are not required. Case 2 will normally be applicable to ditches with flatter grades adjoining the inlet. Case 3 will normally be applicable to ditches with steeper grades adjoining the inlet where build up of the existing ditch is acceptable.
3. The designer shall stipulate in the plans which case is to be constructed at each individual inlet location.

Where the existing inlet top is above the existing ditch (Case 2) but borrow material will be required to adjust the ditch (Case 3), and vertical clearance or other conditions do not prevent removal of the inlet top, the designer should call for Case 2. The designer shall determine if ditch reconstruction is required more than 35 feet beyond any traversable slot side and shall include separate pay items in the plans to cover the cost for that portion of required ditch reconstruction exceeding the 35 foot limit. The designer shall also determine whether ditch pavement is required for ditch restoration within the 35 foot limit and include that pavement under a pay item separate from the inlets partial.

When the detention ditch concept is to be used with Case 3, the designer shall stipulate 'Case 3 (Detention)' in the plans.

The designer shall determine whether tight soil or other conditions at each individual inlet indicates the need for underdrain in Case 3 conversions and shall call for Underdrain, Type 1 in the plans.

METHOD OF PAYMENT FOR TRAVERSABLE SLOT INLETS (PARTIAL) FOR EXISTING INLETS

1. Existing inlets converted to traversable slot tops under Cases 1, 2 and 3 shall be paid for as inlets partial, each. Case shall not be included in the pay item description.
2. All ditch reconstruction work within 35 feet of each traversable slot conversion, whether required by these details or as a direct result of the conversion, shall be included as a part of the partial cost. Reconstruction work shall include excavation and removal of surplus materials or borrow materials in place, grading, compaction, shaping and restoration of disturbed turf. Sodding, ditch pavement and underdrain are not included as part of the inlet partial cost and are to be paid for separately.
3. Concrete inlet pavement and sodding shall be in accordance with the sections on this detail and with the Plan on Sheet 4 and Sections AA, BB and CC (as Case 1) and tabular quantities on Sheet 5.
4. Unit price and payment shall constitute full compensation for inlet conversion (including concrete inlet paving and replacement grate(s)), ditch reconstruction, restoration of disturbed turf, and shall be paid for under the contract price for Inlets (DT Bot) (Type __) (Partial), each.

Sodding shall be paid for under the contract unit price for Performance Turf, SY.

Ditch pavement shall be paid for separate from the inlet by pavement type(s) and unit(s) as called for in the plans.

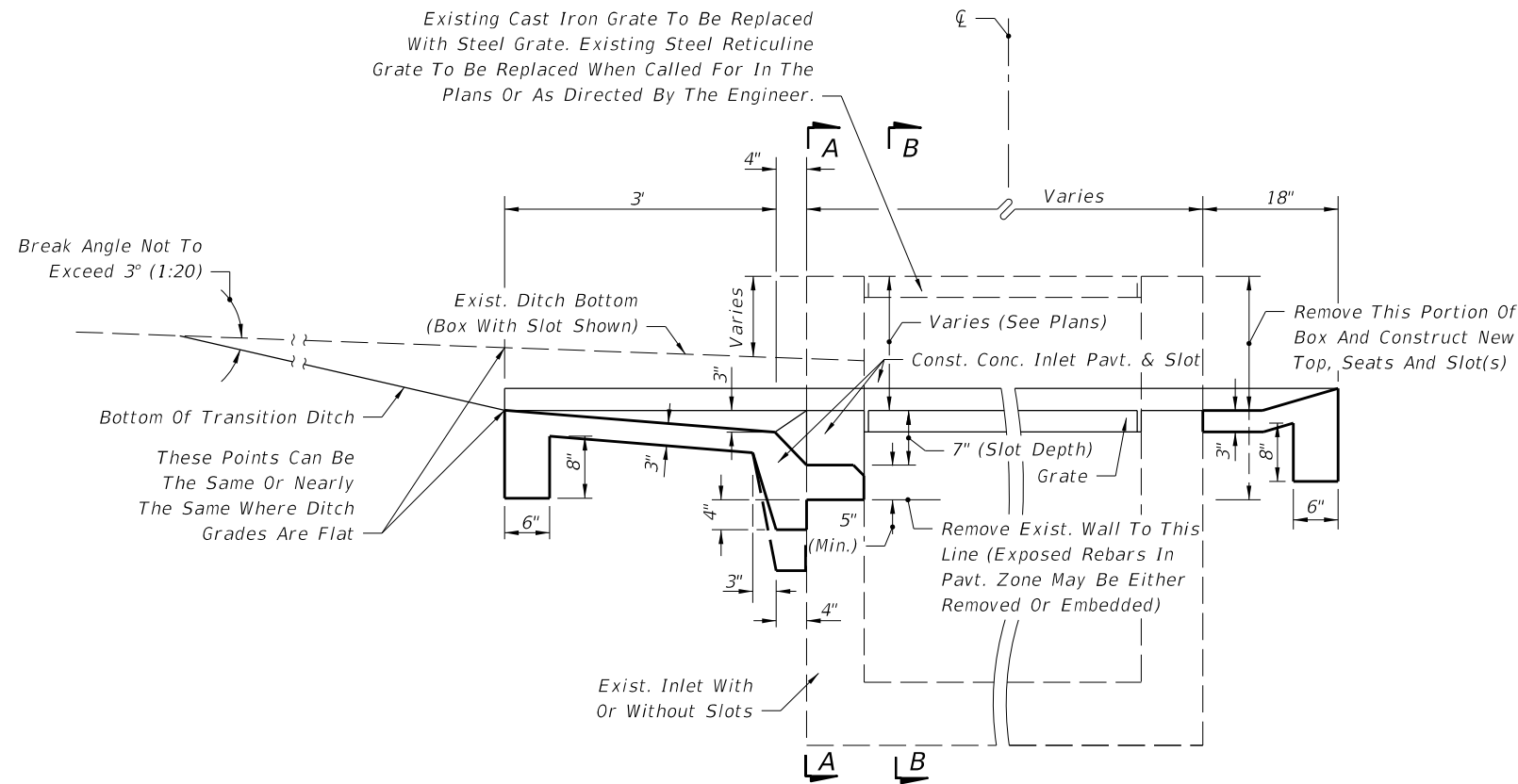

**SINGLE SLOT SHOWN (DOUBLE SLOTS SYMMETRICAL ABOUT CENTERLINE)
SECTION CC (CASE 2)**

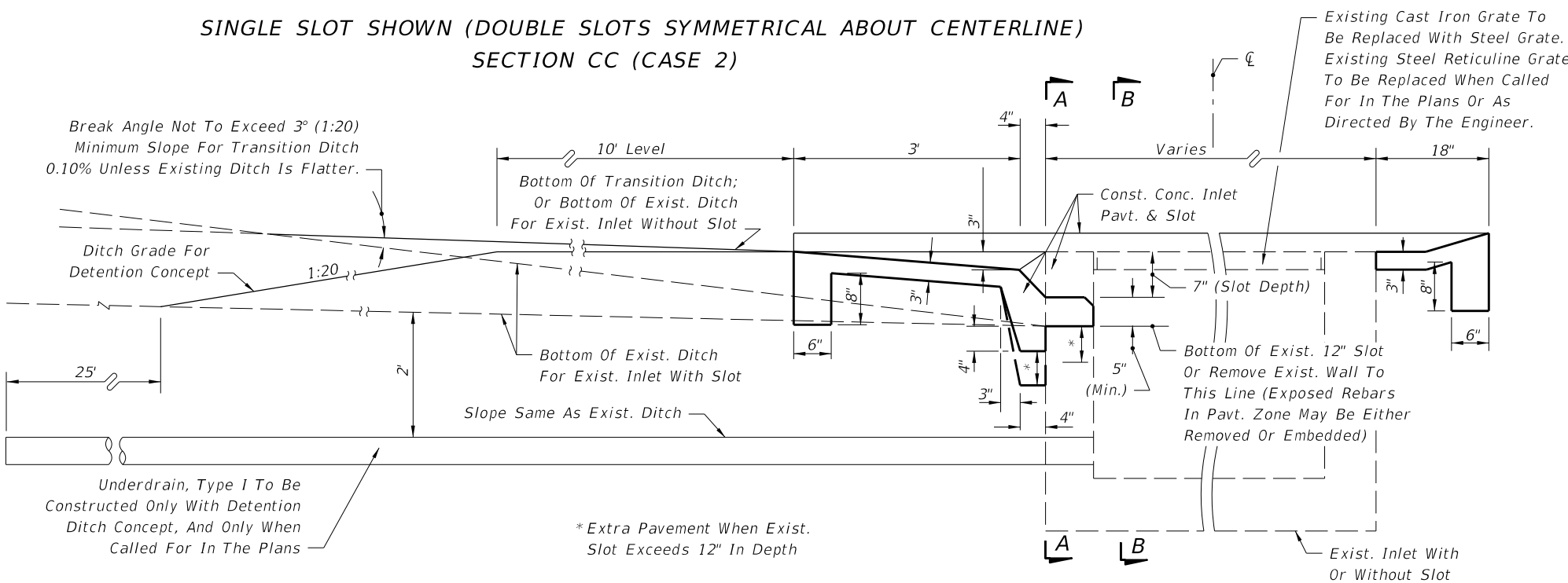

**SINGLE SLOT SHOWN (DOUBLE SLOTS SYMMETRICAL ABOUT CENTERLINE)
SECTION CC (CASE 3)**

TRAVERSABLE SLOT INLETS (PARTIAL) FOR EXISTING INLETS

10/30/2018 8:45:33 AM

LAST REVISION 11/01/17	DESCRIPTION:	 FY 2019-20 STANDARD PLANS	DITCH BOTTOM INLET TYPES C, D, E AND H	INDEX 425-052	SHEET 6 of 7
---------------------------	--------------	-----------------------------------------------------------------------------------------------------------------------	----------------------------------------	------------------	-----------------

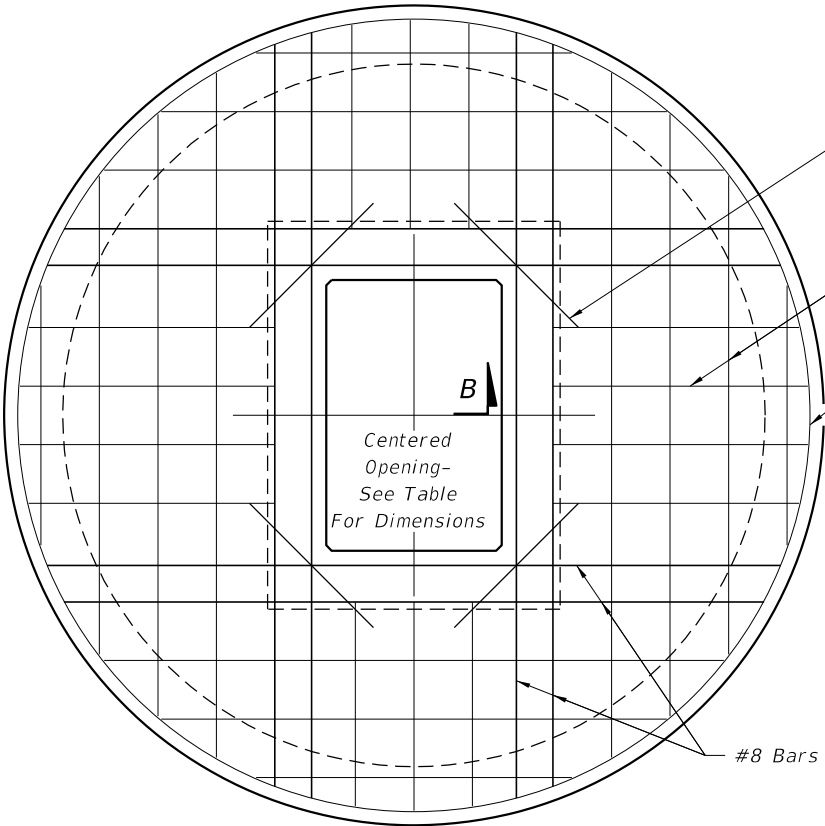
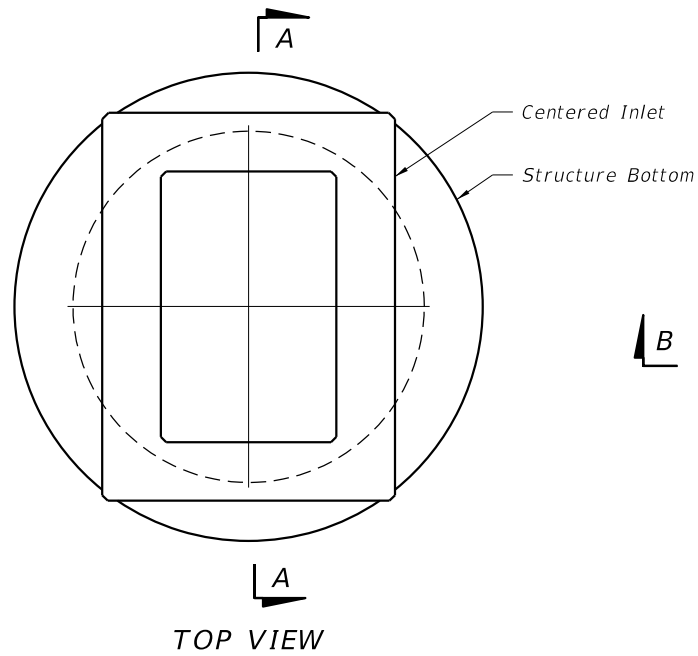

TOP SLAB OPENINGS		
DIAMETER	OPENING SIZE	
	MIN.	MAX.
4'-0"	2'-0" x 3'-1"	2'-0" x 3'-1"
5'-0"	2'-0" x 3'-1"	3'-1" x 4'-1"
6'-0"	2'-0" x 3'-1"	3'-0" x 4'-6"
8'-0"	2'-0" x 3'-1"	3'-0" x 4'-6"

TOP SLAB REINFORCING DIAGRAM

TOP SLAB REINFORCING SCHEDULE	
SCHEDULE	GRADE 60 (BAR) OR 65 KSI & 70 KSI (WIRE FABRIC) In. ² /ft.
A	0.20
B	0.24
C	0.37
D	0.53
E	0.73
F	1.06
G	1.45

TOP SLAB WITH CENTERED OPENING		
SLAB DEPTH	SLAB THICKNESS	REINFORCING (2 WAYS) SCHEDULE
SIZE: 4'-0"		
≥0.5'-40'	9½"	C
SIZE: 5'-0"		
≥0.5' < 30'	9½"	C
30'-40'	9½"	D
SIZE: 6'-0"		
0.5' < 8'	9½"	B
8' < 18'	9½"	C
18' < 30'	9½"	D
30' < 37'	9½"	E
37'-40'	9½"	G
SIZE: 8'-0"		
≥0.5' < 9'	11½"	C
9' < 15'	11½"	D
15' < 23'	11½"	E
23' < 33'	11½"	E
33'-40'	11½"	G

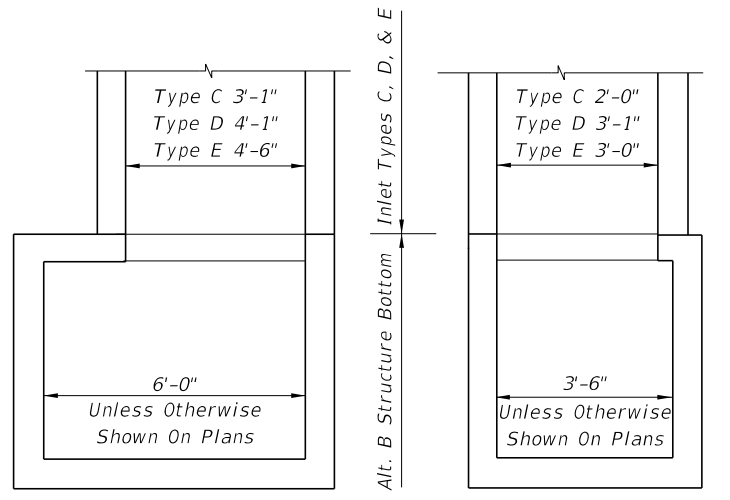

See Index 425-010 for structure bottom details and hole reinforcement.

ALT. B STRUCTURE BOTTOM FOR INLETS TYPE C, D & E

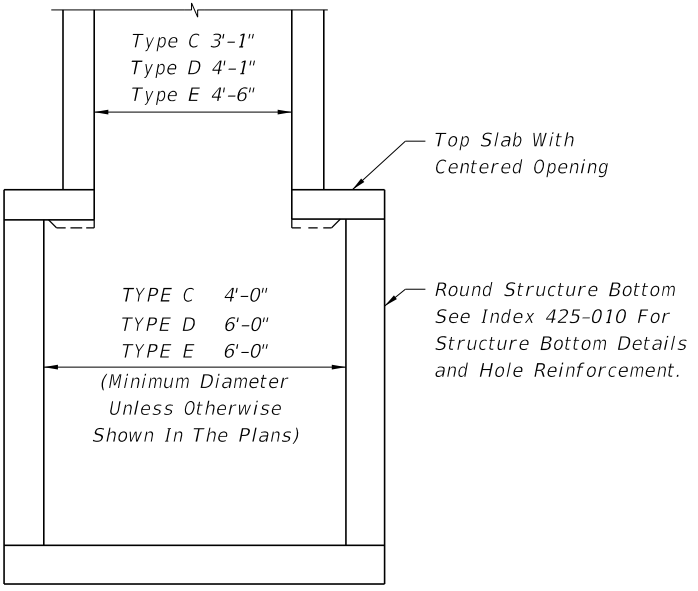

SECTION AA

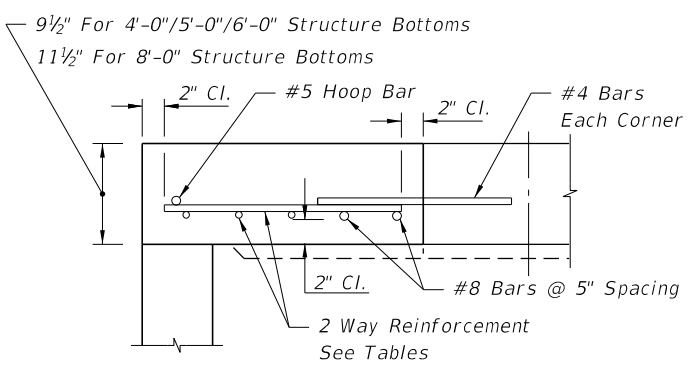

SECTION BB

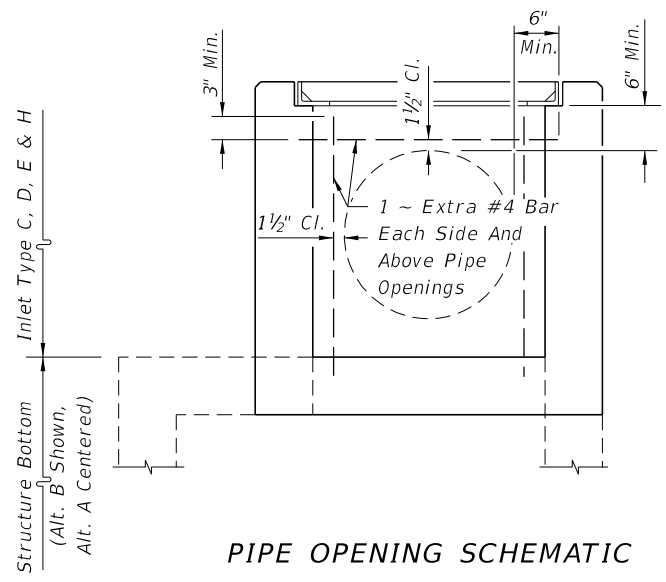

PIPE OPENING SCHEMATIC

ALT. A STRUCTURE BOTTOM FOR INLETS TYPE C, D AND E

10/30/2018 8:45:37 AM

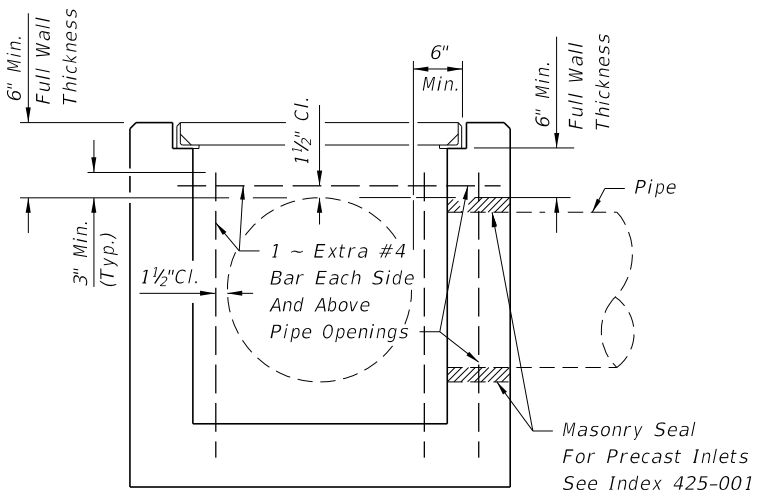
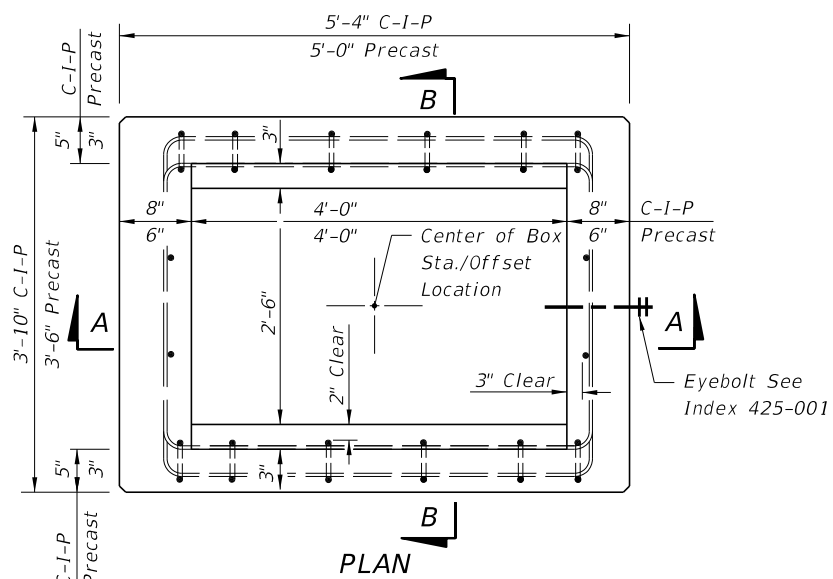

(TYPE F SHOWN, TYPE G SIMILAR)
PIPE OPENING SCHEMATIC

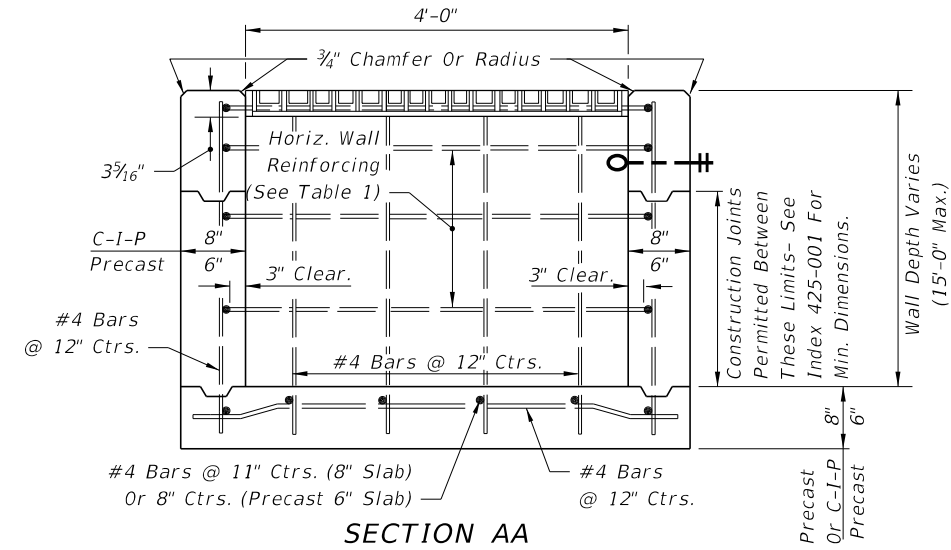

SECTION AA

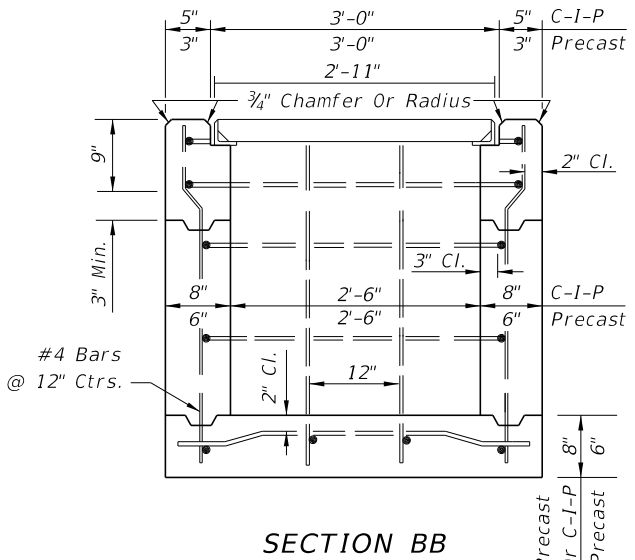

SECTION BB

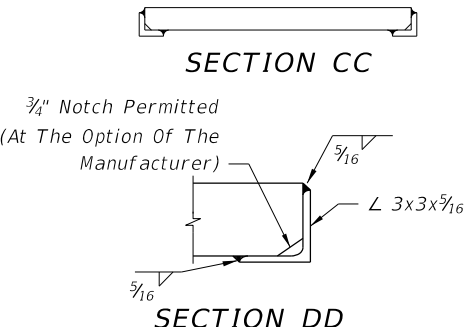

SECTION CC

SECTION DD

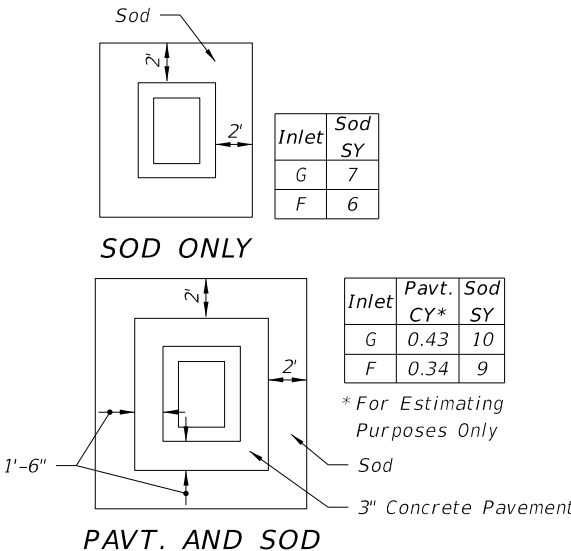

PAVT. AND SOD

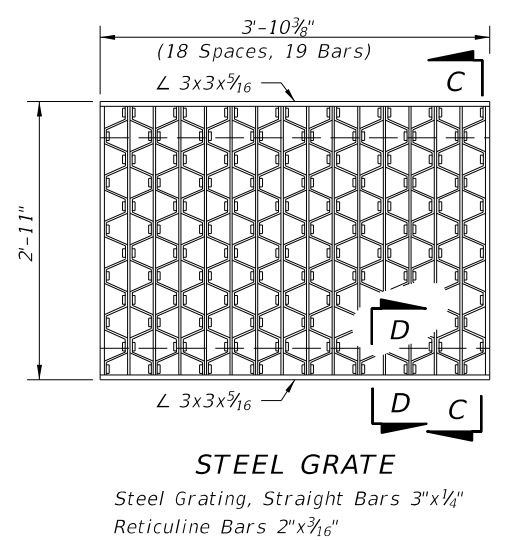

STEEL GRATE

Steel Grating, Straight Bars 3"x1/4"
Reticuline Bars 2"x3/16"

TYPE F

GENERAL NOTES

- These inlets are designed for use in ditches, medians, pavement areas, or other areas subject to heavy wheel loads, minimal debris, and bicycle traffic. This inlet may be placed in areas subject to occasional pedestrian traffic such as landscaped areas and pavement areas where pedestrians can walk around the inlet. When inlet is placed in areas subject to bicycle traffic, install filler bar when clearance or gap is greater than 5/8" as shown in Index 425-031.
- When Alternate G grate is specified in plans, the grate is to be hot dip galvanized after fabrication.
- These inlets may be used with Alternate B structure bottoms, Index 425-010. The inlet and bottom combinations are to be paid for under the contract unit price for inlets (DT Bot) (Type F (or G)) (J Bot, Depth), Ea.
- All exposed edges and corners shall be 3/4" chamfer or tooled to 1/4" radius.
- For supplemental details, see Index 425-001.
- All reinforcing is Grade 60 bars with 2" min. cover unless otherwise noted. Bars to be cut or bent for 1 1/2" clearance around pipe opening. Provide one additional #4 bar above and at each side of pipe opening, as shown.
- All dimensions are for both precast and cast-in-place inlets unless otherwise noted.

RECOMMENDED MAXIMUM PIPE SIZES

INLET INSIDE WIDTH	PIPE SIZE
2'-6" (Type F)	18"
4'-0" (Type F)	30"
4'-10" / 5'-0" (Type G)	42"

Note: Recommended sizes are for concrete pipe. Sizes for other types of pipe must be verified for fit in accordance with Index 425-001. For larger pipe sizes see Note 3.

HORIZONTAL WALL REINF. SCHEDULES
TYPE F INLET (TABLE 1)

WALL DEPTH	SCHEDULE	AREA (in ² /ft)	MAX. SPACING	
			BARS	WWF
0' - 4'	A12	0.20	12"	8"
4' - 7'	A6	0.20	6"	5"
7' - 12'	B5.5	0.24	5 1/2"	5"
12' - 15'	Special 1	0.267	5"	4"

10/30/2018 8:45:41 AM

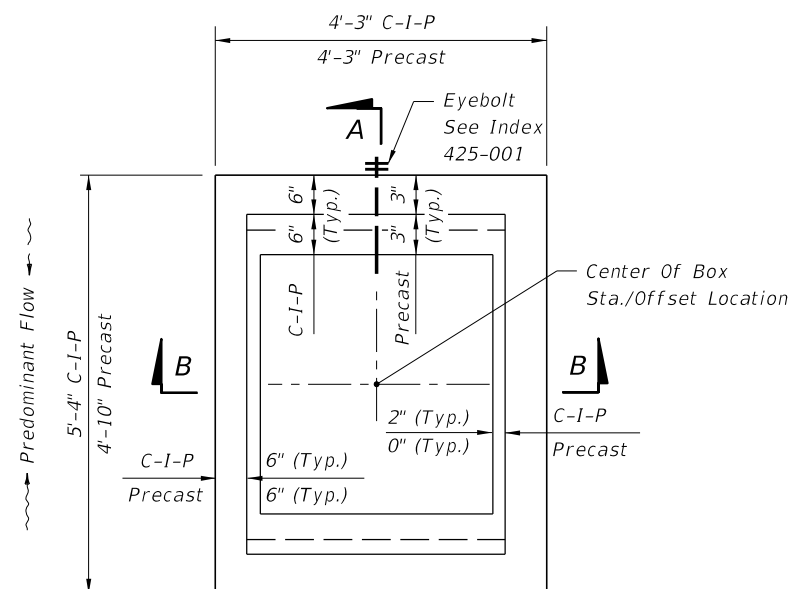

PLAN
(CAST-IN-PLACE INLET SHOWN, WITHOUT GRATE, PRECAST INLET SIMILAR)

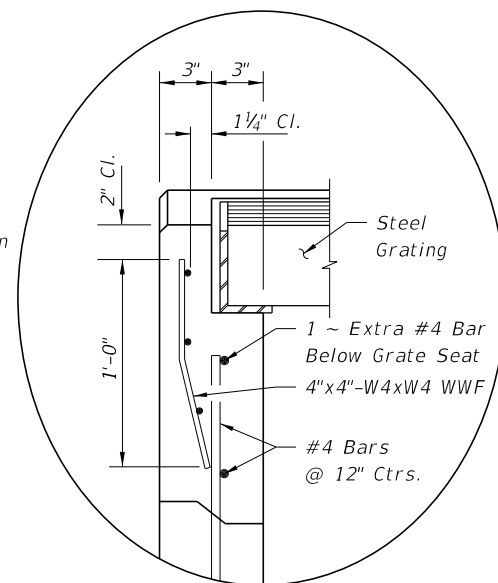

INSET A
(PRECAST OPTION)

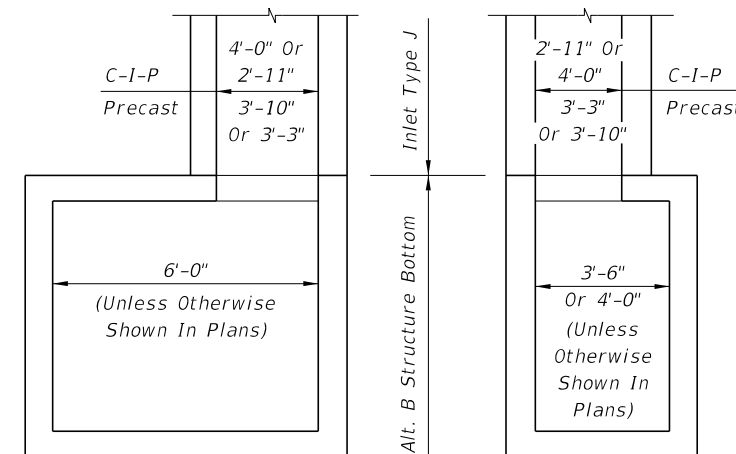

NOTE: Alt. B Structure Bottom Only. See Index 425-010 for structure bottom details and hole reinforcement.

INLET WITH STRUCTURE BOTTOM

HORIZONTAL WALL REINFORCING SCHEDULE (TABLE 1)

WALL DEPTH	SCHEDULE	AREA (In ² /ft)	MAX. SPACING	
			BARS	WWF
0' - 4'	A12	0.20	12"	8"
4' - 9'	A6	0.20	6"	5"
9' - 12'	A4	0.20	4"	3"
9' - 15'	B5.5	0.24	5 1/2"	5"

RECOMMENDED MAXIMUM PIPE SIZES

INLET INSIDE WIDTH	PIPE SIZE
2'-11" or 3'-3"	24"
3'-10" or 4'-0"	30"

Note: Recommended sizes are for concrete pipe. Sizes for other types of pipe must be verified for fit in accordance with Index 425-001. For larger pipe, see Structure Bottom detail above and Index 425-010.

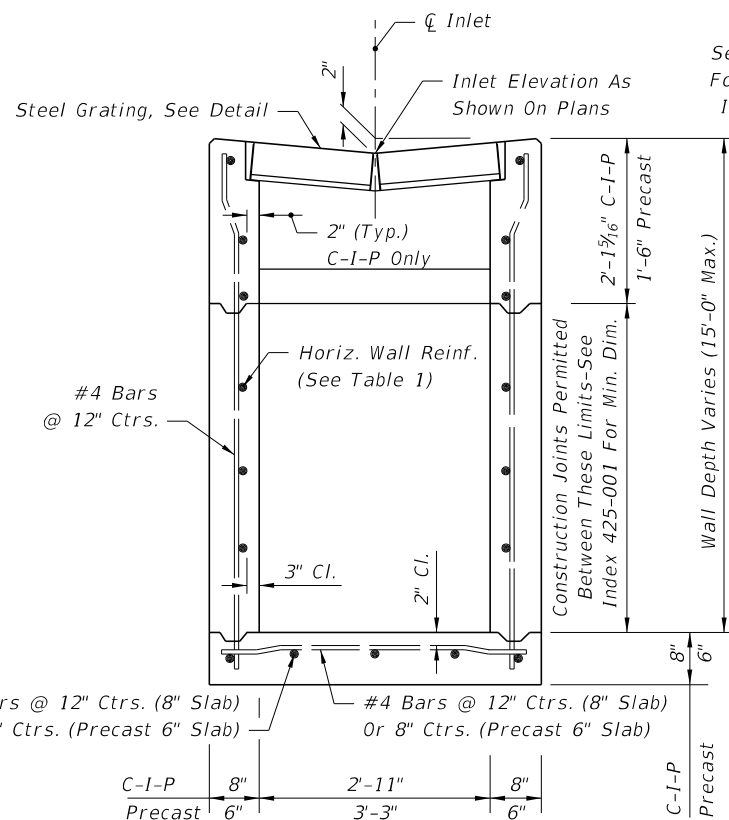

(Pipe Opening Not Shown)
SECTION BB

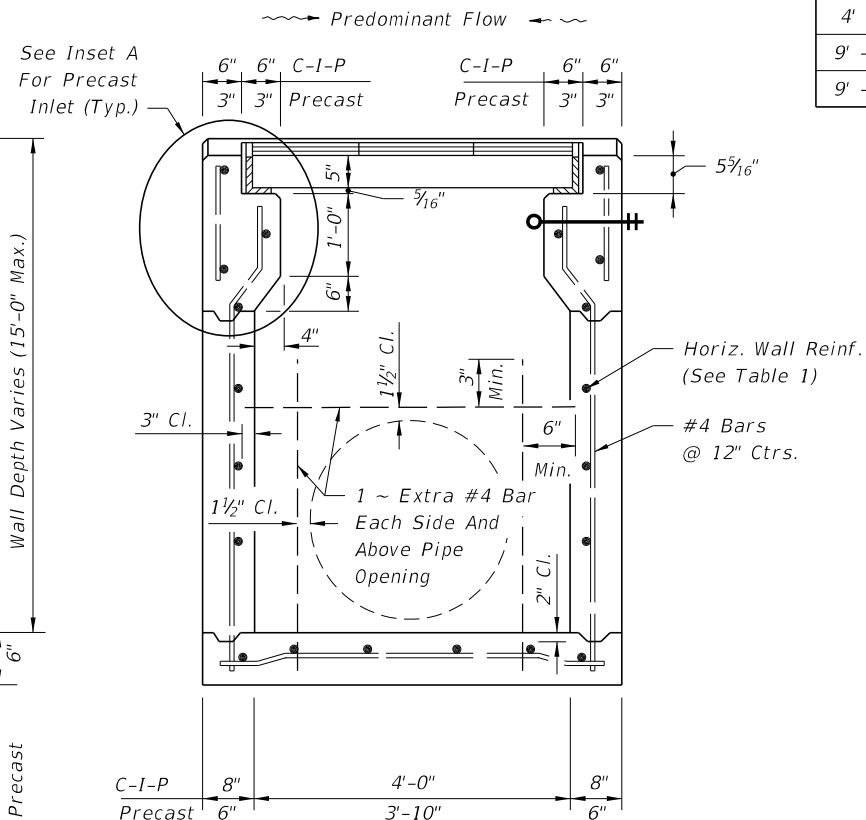

(Pipe Opening Shown)
SECTION AA

GENERAL NOTES

1. This inlet is designed for use in ditches, medians, pavement areas or other areas subject to heavy wheel loads with minimal debris. This inlet is not for use in areas subject to bicycle traffic. This inlet may be placed in areas subject to occasional pedestrian traffic such as landscaped areas and pavement areas where pedestrians can walk around the inlet.
2. All reinforcing Grade 60 bars with 2" min. cover unless otherwise noted. See Index 425-001 for equivalent area of welded wire fabric. Cut or bend bars out of way of pipe when necessary; bars to clear pipe by 1 1/2".
3. All exposed edges and corners shall be 3/4" chamfer or tooled to 1/4" radius.
4. When alternate G grate is specified in plans the grate is to be hot dip galvanized after fabrication.
5. For supplemental details, see Index 425-001.
6. All dimensions are for both precast and cast-in-place inlets unless otherwise noted.
7. Cost of ditch paving to be included in cost of inlet. Sodding to be paid for under contract unit price for Performance Turf, SY.

10/30/2018 8:45:48 AM

LAST REVISION 11/01/17	DESCRIPTION:
---------------------------	--------------

FY 2019-20
STANDARD PLANS

DITCH BOTTOM INLET TYPE J

INDEX 425-054	SHEET 1 of 2
------------------	-----------------

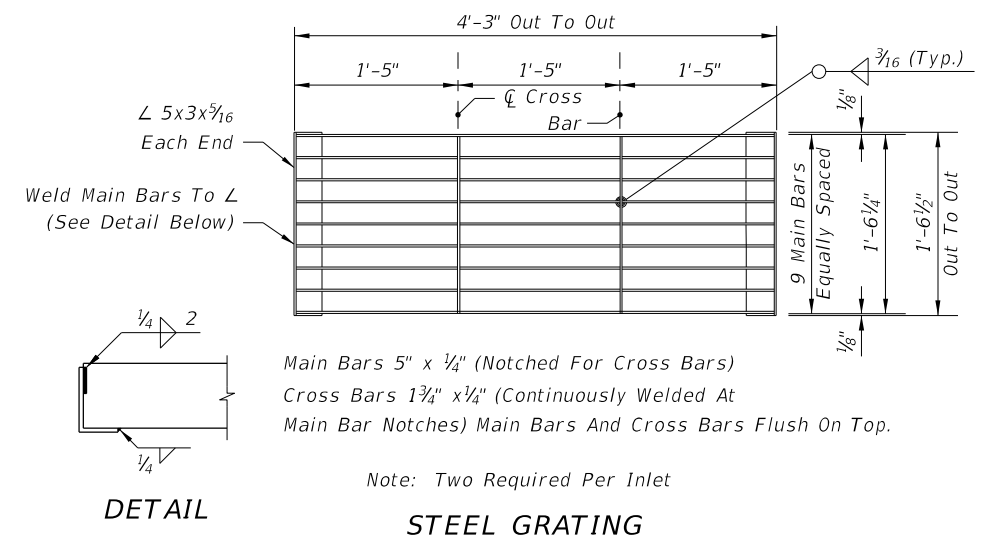
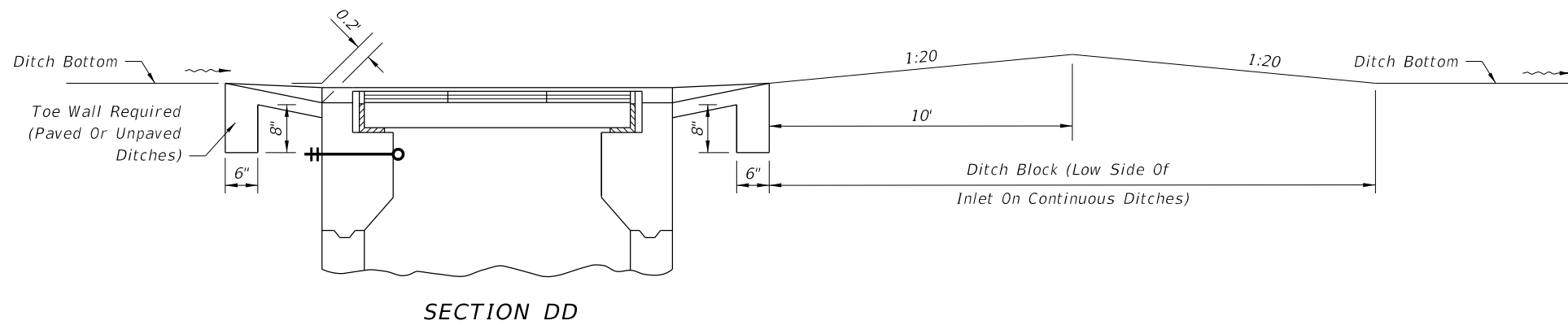
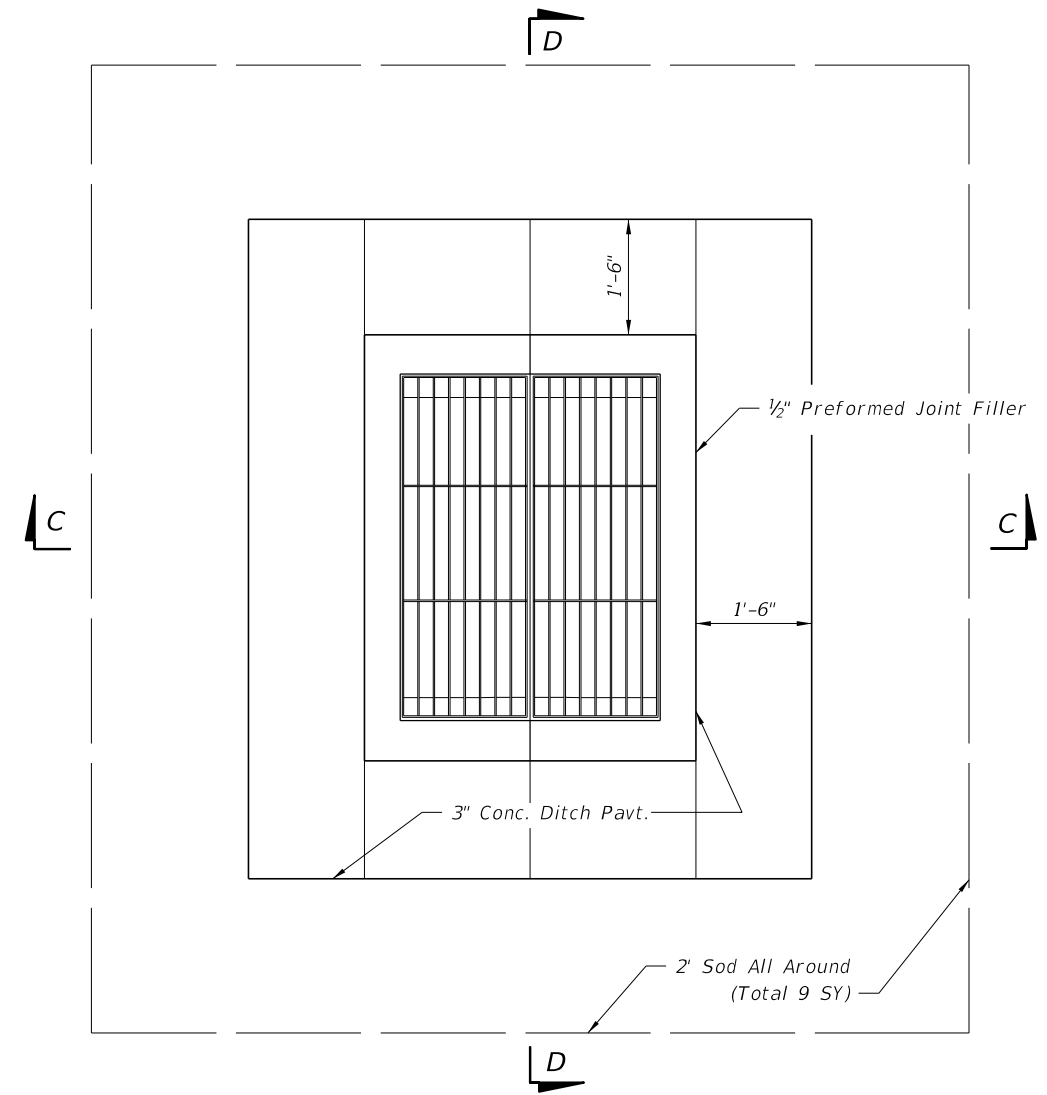
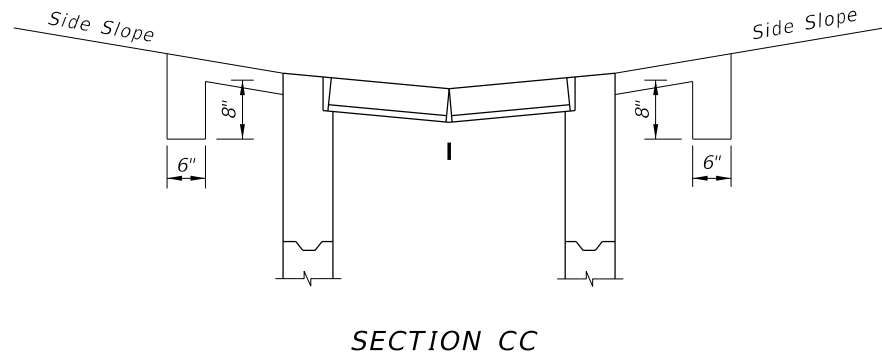

10/30/2018 8:45:51 AM

LAST REVISION	DESCRIPTION:
11/01/17	



FY 2019-20
STANDARD PLANS

DITCH BOTTOM INLET TYPE J

INDEX
425-054

SHEET
2 of 2

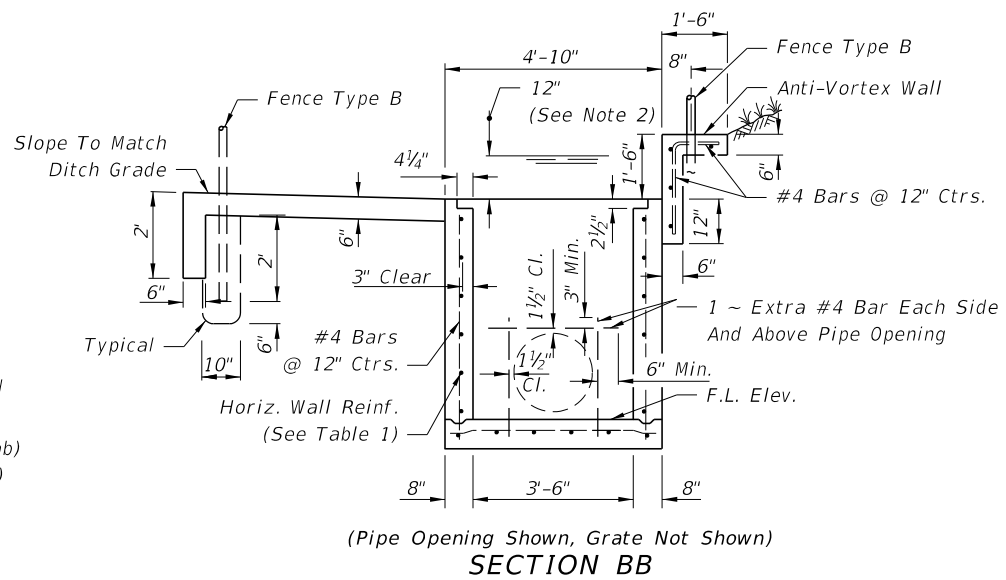
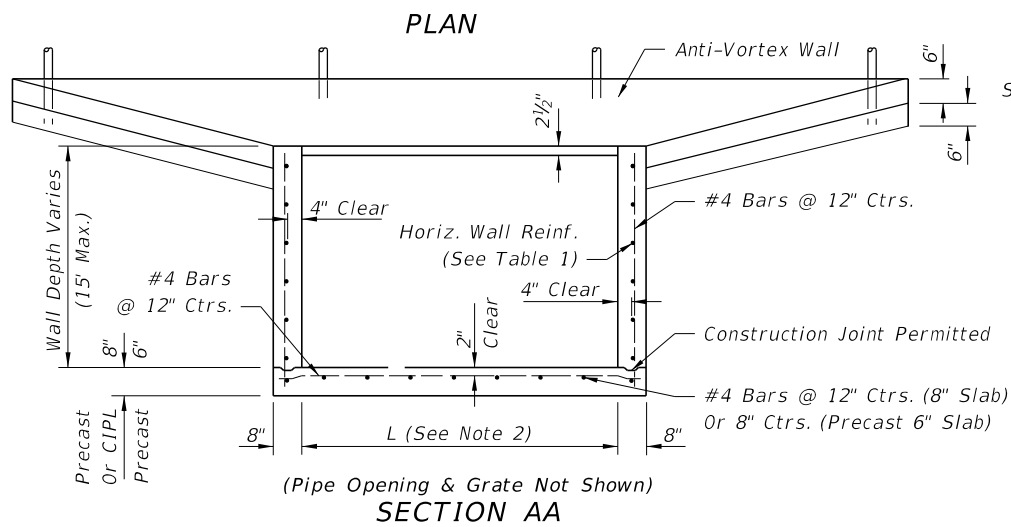
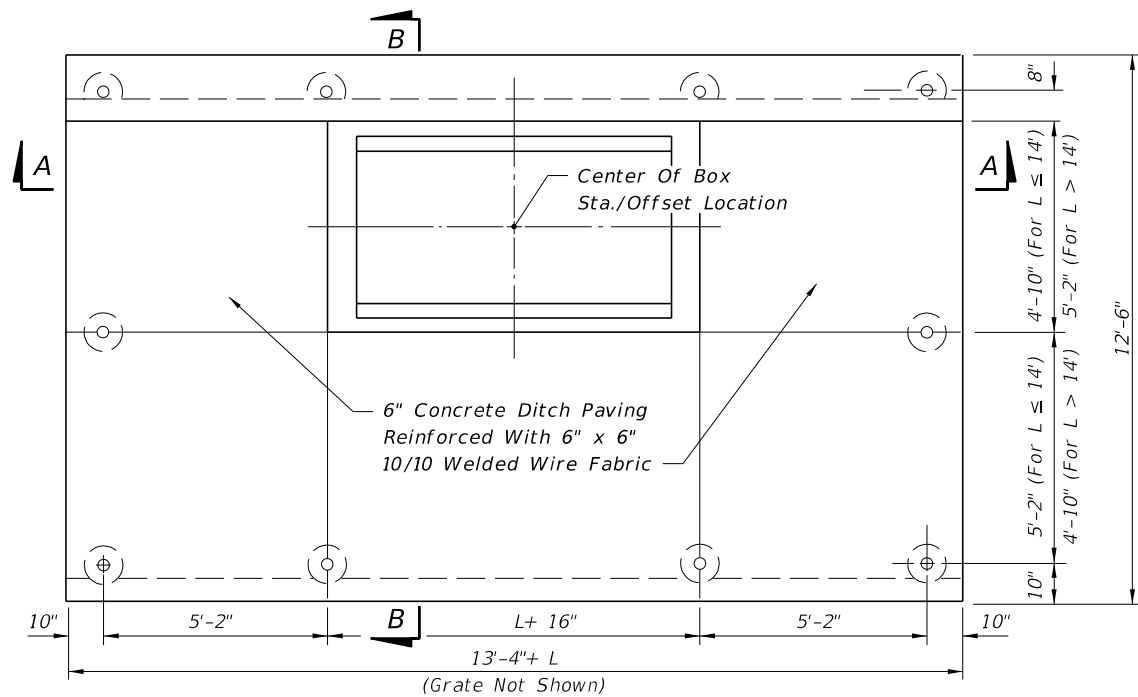

INLET LENGTHS (L) LESS THAN OR EQUAL TO 9' (SINGLE LAYER WALL REINFORCING)

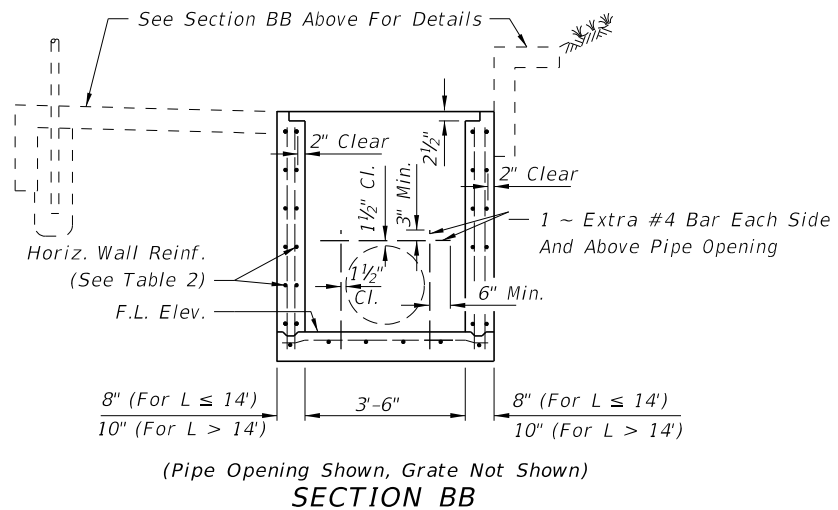
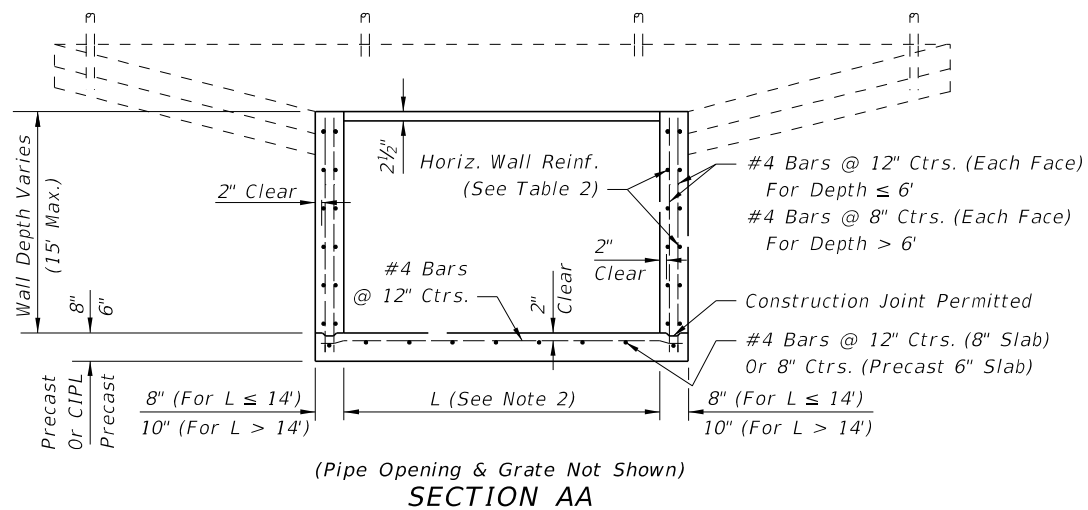

INLET LENGTHS (L) GREATER THAN OR EQUAL TO 9' (DOUBLE LAYER WALL REINFORCING)

GENERAL NOTES

1. This inlet is to be used at locations having high flow rates, usually where an endwall could not be utilized without hazardous intake.
2. Inlet length (L) shall be set by the designer for the greater of either culvert requirement or inlet pool not to exceed 12" depth. Structures over 6 feet in depth are to be checked for flotation by the designer of project drainage.
3. This inlet is not intended for use with Index 425-010 structure bottoms.
4. All exposed edges and corners shall be 3/4" chamfer or tooled to 1/4" radius.
5. Inlet and anti-vortex wall to be Class II Concrete.
6. All reinforcing is Grade 60 with 2" min. cover unless otherwise noted. See Index 425-001 for equivalent area of welded wire fabric (WWF). Bars to be cut or bent for 1 1/2" clearance around pipe opening. Bend top and corner bars to clear anchor holes.
7. Channel section C 3x6 at 14" max. bar spacing may be used as an alternate for the C 4x5.4 channel at 15" bar spacing.
8. Channels and bars for grate shall be ASTM A242/A242M, A572/A572M or A588/A588M, Grade 50 steel, and galvanized in accordance with Specification Section 975.
9. Fence enclosure shall be Fence Type B (Index 550-002). All posts to be set in concrete. A minimum of 10 posts required. Corner and approach side posts to be 3" nominal diameter.
10. Cost of ditch paving, anti-vortex wall, grate, concrete, reinforcing steel and fence enclosure to be included in the cost of inlet. Inlet to be paid for under the contract unit price for Inlets (DT Bot) (Type K), Each.
11. Anchor Bolts shall be ASTM F1554 Grade 36 fully threaded headless bolts, installed in accordance with Specification Sections 416 and 937. Nuts shall be ASTM A563 or A194 and washers shall be ASTM F436 or Type A plain washers. All nuts, bolts and washers shall be galvanized.

10/30/2018 8:45:57 AM

LAST REVISION 11/01/17	DESCRIPTION:	 FY 2019-20 STANDARD PLANS	DITCH BOTTOM INLET TYPE K	INDEX 425-055	SHEET 1 of 2
---------------------------	--------------	----------------------------------	---------------------------	------------------	-----------------

HORIZONTAL WALL REINFORCING SCHEDULES

WALL DEPTH	SCH.	AREA (in ² /ft)	MAX. SPACING BARS	WWF
SIZE: L = 5'-0"				
0'-5'	A12	0.20	12"	8"
5'-8'	A6	0.20	6"	5"
8'-15'	B5.5	0.24	5½"	5"
SIZE: L = 6'-0"				
0'-4'	A12	0.20	12"	8"
4'-6'	B5.5	0.24	5½"	5"
6'-9'	C6.5	0.37	6½"	6"
9'-15'	C3.5	0.37	3½"	3"
SIZE: L = 7'-0"				
0'-4'	B5.5	0.24	5½"	5"
4'-7'	C6.5	0.37	6½"	6"
7'-15'	D4.5	0.53	4½"	4"
SIZE: L = 8'-0"				
0'-3'	B5.5	0.24	5½"	5"
3'-5'	C6.5	0.37	6½"	6"
5'-9'	D4.5	0.53	4½"	4"
9'-15'	E5	0.73	5"	4"
SIZE: L = 9'-0"				
0'-4'	C6.5	0.37	6½"	6"
4'-7'	D4.5	0.53	4½"	4"
7'-15'	E3	0.73	3"	3"

WALL DEPTH	SCH.	AREA (in ² /ft)	MAX. SPACING BARS	WWF
SIZE: L = 9'-0"				
0'-4'	A12	0.20	12"	8"
4'-6'	A6	0.20	6"	5"
6'-8'	B5.5	0.24	5½"	5"
8'-15'	C6.5	0.37	6½"	6"
SIZE: L = 10'-0"				
0'-3'	A12	0.20	12"	8"
3'-5'	A6	0.20	6"	5"
5'-8'	C6.5	0.37	6½"	6"
8'-15'	C3.5	0.37	3½"	3"
SIZE: L = 12'-0"				
0'-4'	B5.5	0.24	5½"	5"
4'-6'	C6.5	0.37	6½"	6"
6'-15'	D4.5	0.53	4½"	4"
SIZE: L = 14'-0"				
0'-4'	C6.5	0.37	6½"	6"
4'-7'	D4.5	0.53	4½"	4"
7'-15'	E5	0.73	5"	4"
SIZE: L = 16'-0" x 10" WALL THICK				
0'-4'	C6.5	0.37	6½"	6"
4'-8'	D4.5	0.53	4½"	4"
8'-15'	E5	0.73	5"	4"
SIZE: L = 18'-0" x 10" WALL THICK				
0'-3'	C6.5	0.37	6½"	6"
3'-5'	D4.5	0.53	4½"	4"
5'-8'	E5	0.73	5"	4"
8'-15'	F5	1.06	5"	4"

GRATE QUANTITIES

PIPE SIZE	L	S	BILL OF STEEL			STEEL WEIGHT		
			BAR	No. REQD.	LENGTH	CHANNEL 4"x 5.4 lb	ANGLE 3"x 2½"x ¼" (4.5 lb/ft)	FLAT 2" x ½" (3.4 lb/ft)
30" & 36"	5'-0"	12¾"	A	5	4'-1½"	111	45	51
			B	2	4'-11½"			
			C	3	4'-11½"			
42" & 48"	6'-0"	11¼"	A	6	4'-1½"	134	54	61
			B	2	5'-11½"			
			C	3	5'-11½"			
54" & 60"	7'-0"	9¾"	A	7	4'-1½"	156	63	71
			B	2	6'-11½"			
			C	3	6'-11½"			
66" & 72"	8'-0"	8¼"	A	8	4'-1½"	178	72	81
			B	2	7'-11½"			
			C	3	7'-11½"			
84"	9'-0"	14¼"	A	8	4'-1½"	178	81	91
			B	2	8'-11½"			
			C	3	8'-11½"			
SPECIAL	10'-0"	12¾"	A	9	4'-1½"	201	90	102
			B	2	9'-11½"			
			C	3	9'-11½"			
SPECIAL	12'-0"	9¾"	A	11	4'-1½"	245	108	122
			B	2	11'-11½"			
			C	3	11'-11½"			
SPECIAL	14'-0"	14¼"	A	12	4'-1½"	267	126	142
			B	2	13'-11½"			
			C	3	13'-11½"			
SPECIAL	16'-0"	11¼"	A	14	4'-1½"	312	144	163
			B	2	15'-11½"			
			C	3	15'-11½"			
SPECIAL	18'-0"	8¼"	A	16	4'-1½"	356	162	183
			B	2	17'-11½"			
			C	3	17'-11½"			

Table Notes:
 See Sheet 1 for dimension "L" location.
 See steel grate Plan View for dimension "S" location.

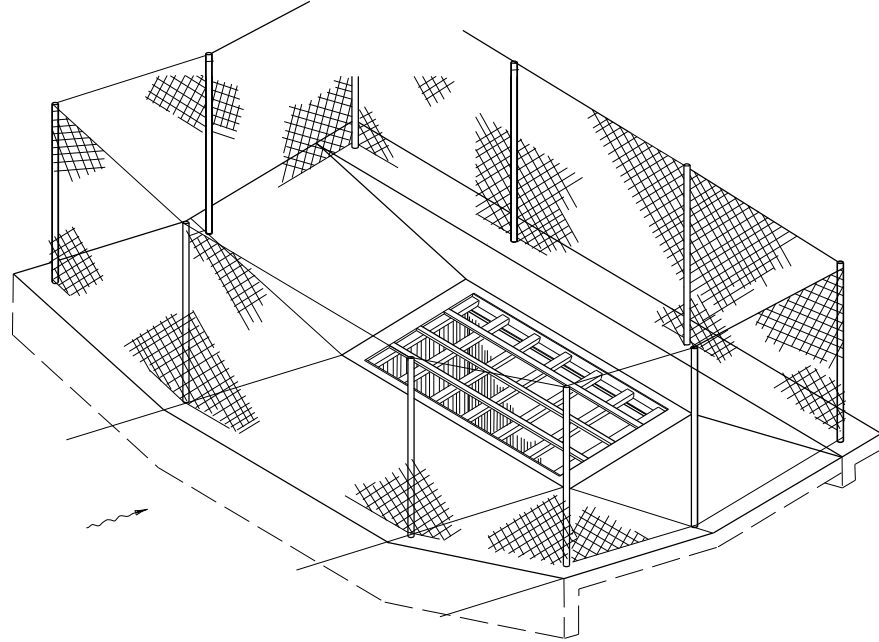

ISOMETRIC OF INLET FENCE ENCLOSURE

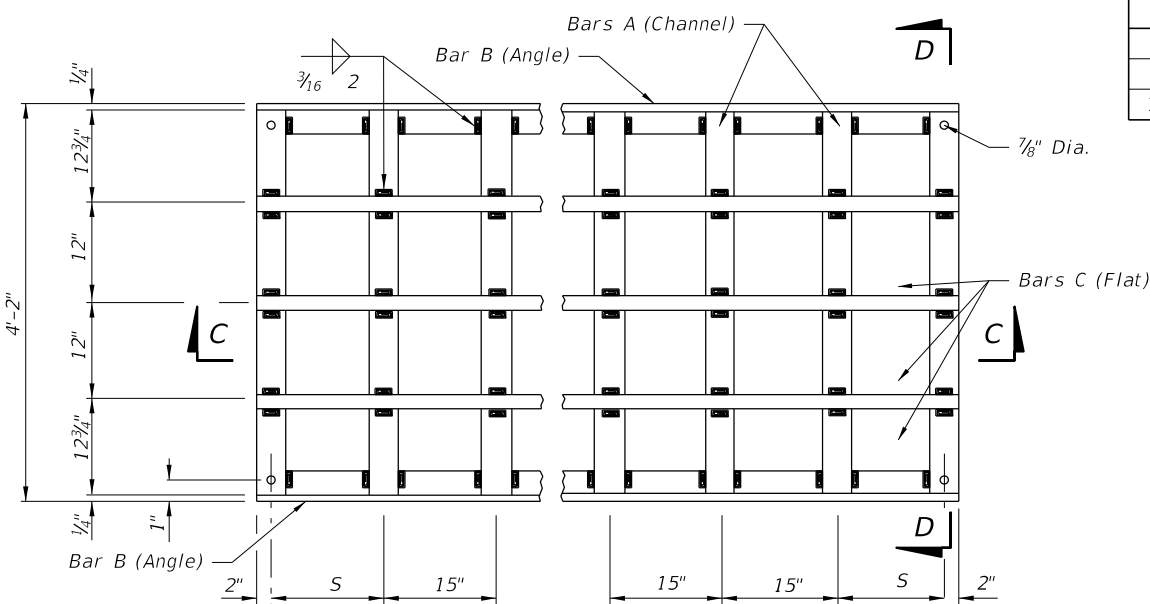

SINGLE LAYER REINFORCING (TABLE 1)

DOUBLE LAYER REINFORCING (TABLE 2)

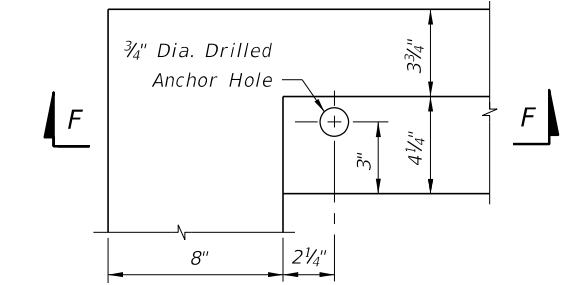
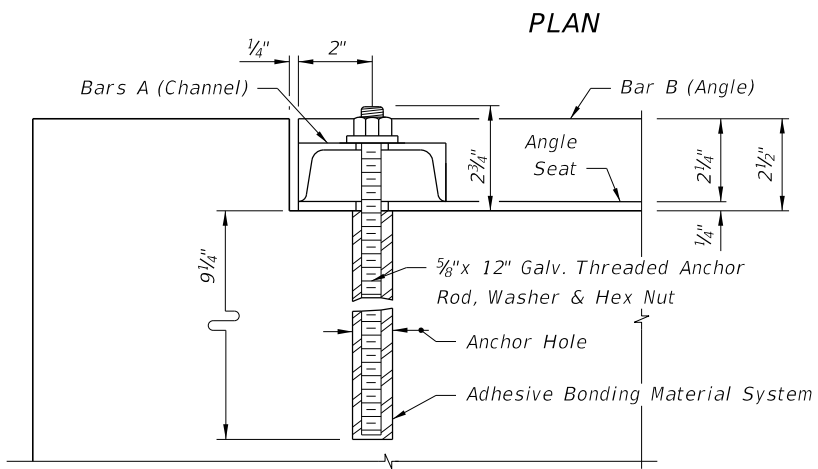

GRATE SEAT AND ANCHOR HOLE PLAN

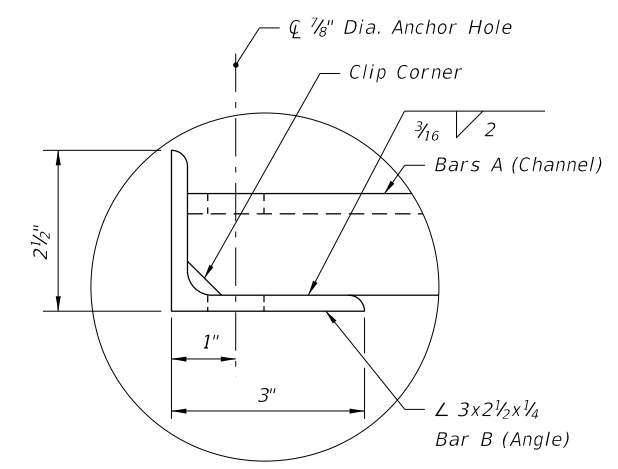
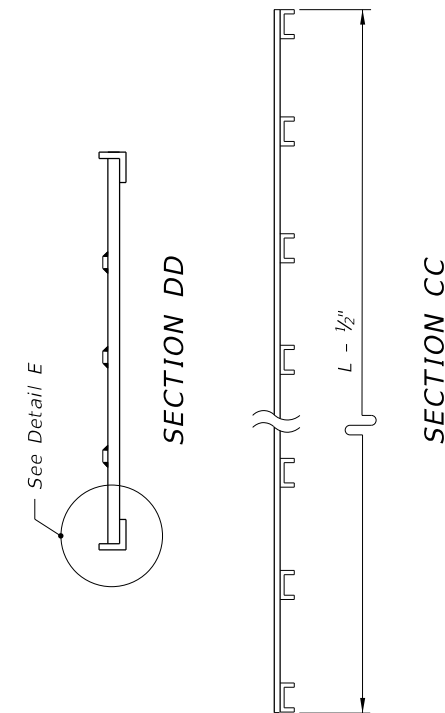

DETAIL E

10/30/2018 8:46:01 AM

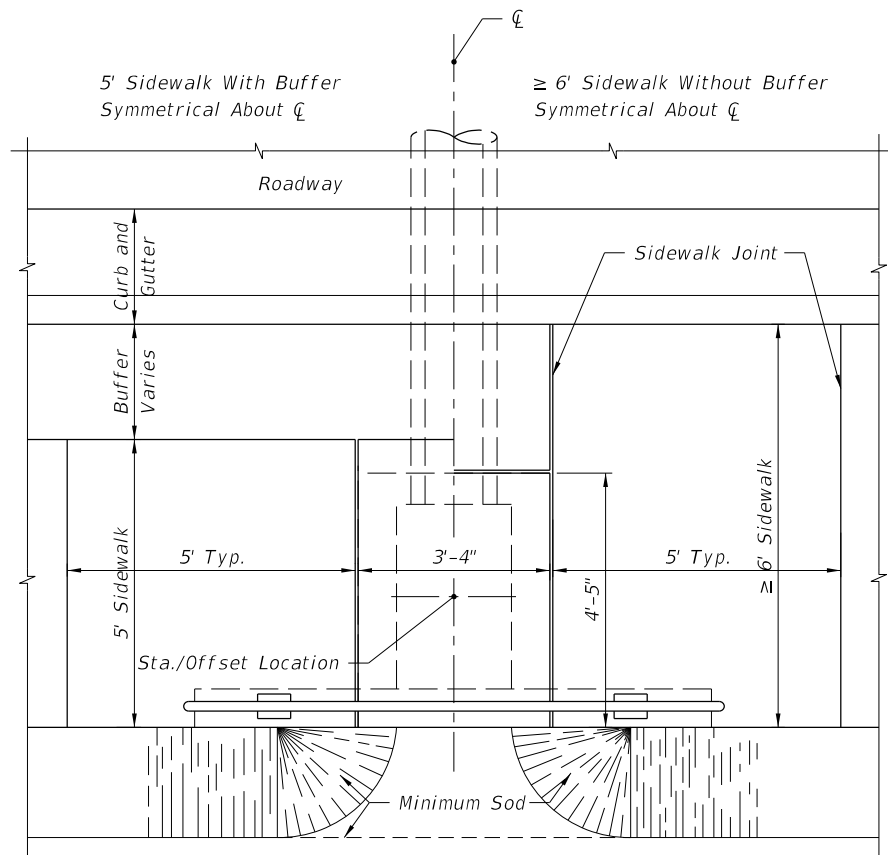

PLAN

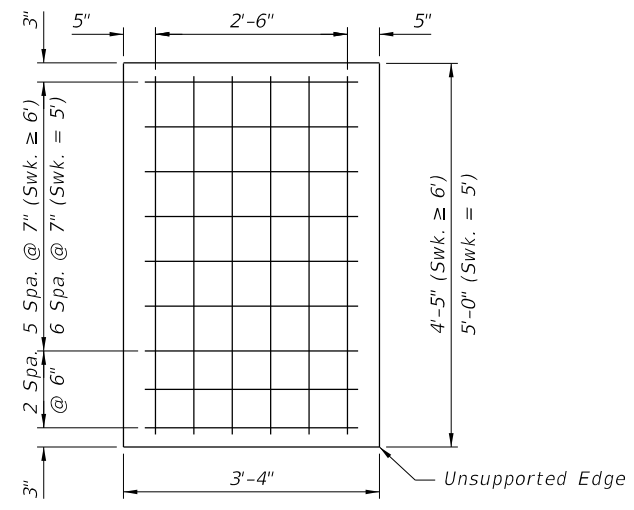

SLAB REINFORCEMENT

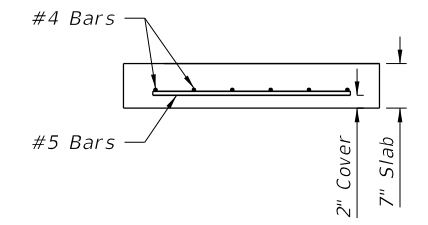

SLAB SECTION

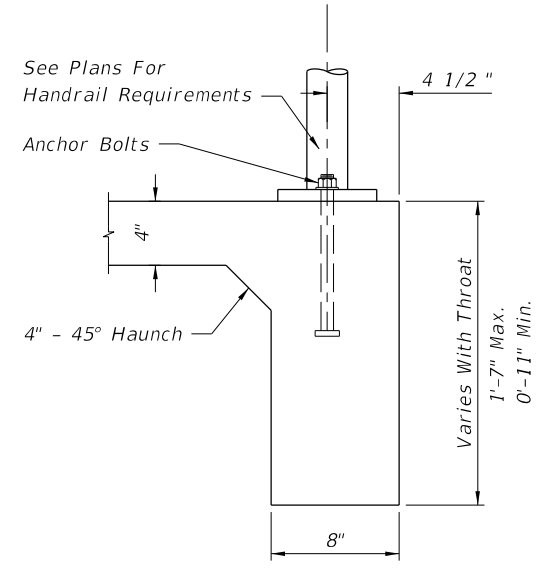

SECTION BB

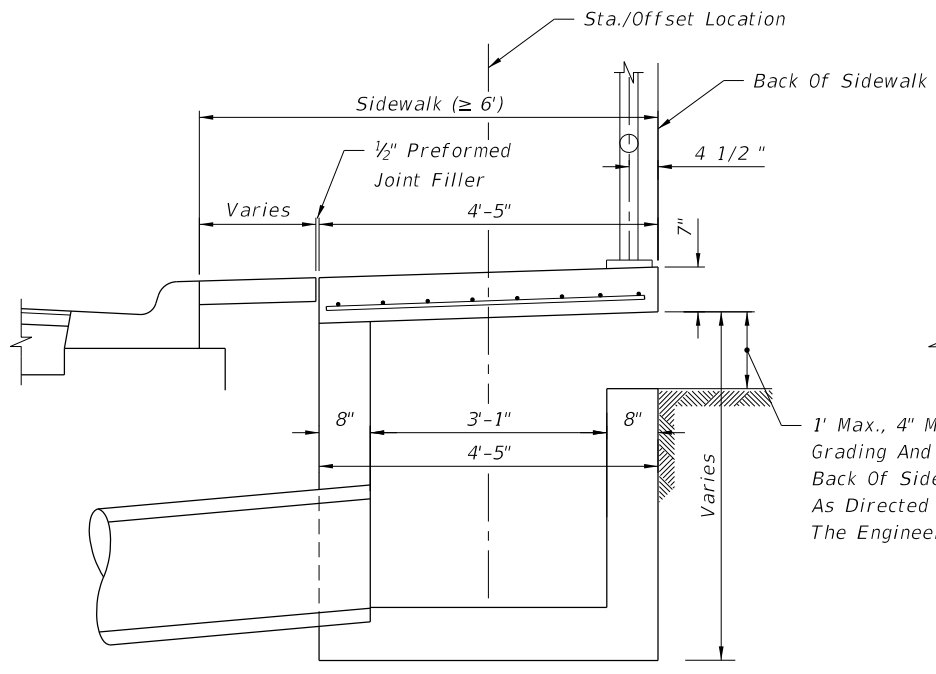

≥ 6' SIDEWALK SECTION AA

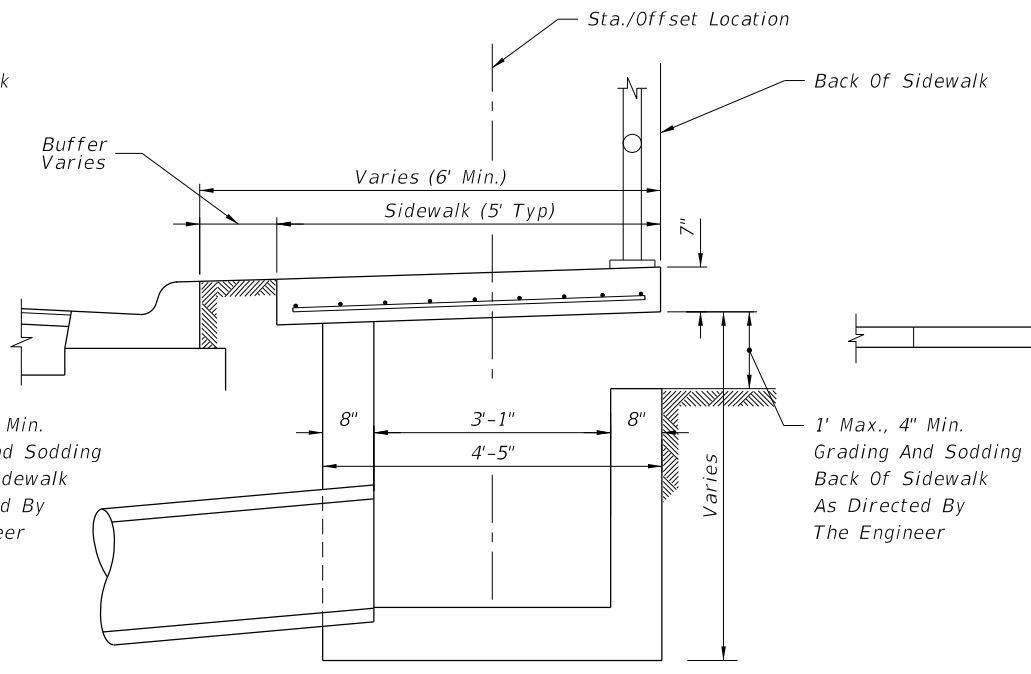

5' SIDEWALK SECTION AA

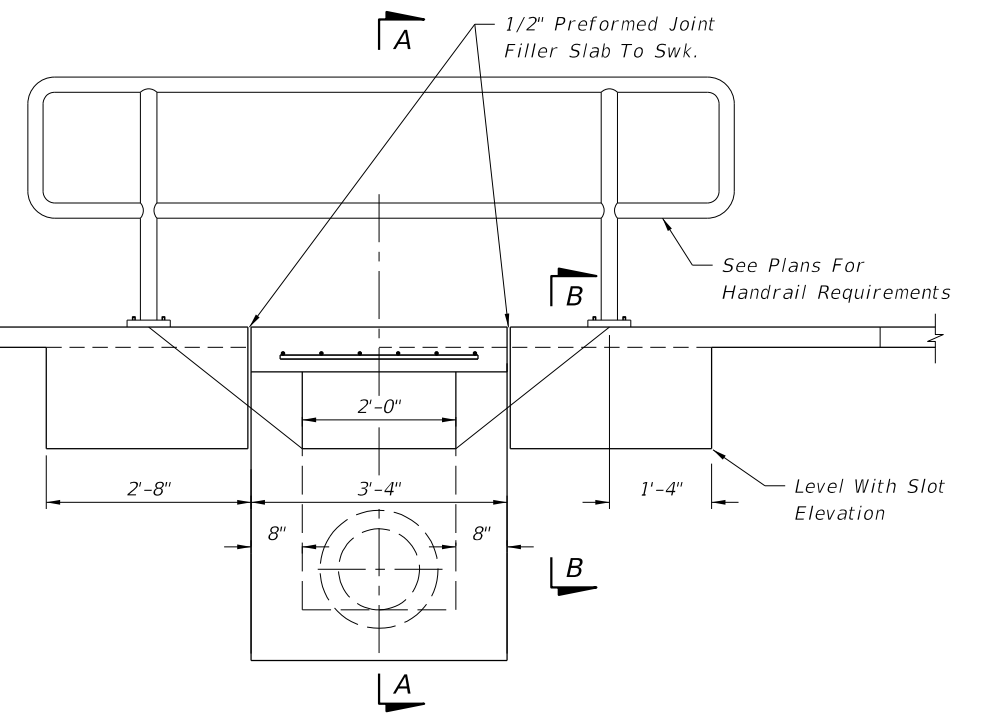

FRONT ELEVATION

- Notes:
1. For additional details see Index 425-052.
 2. Inlet to be paid for under the contract unit price for Inlets (Ditch Bottom Type C Modified), EA. Handrail to be paid for under the contract unit price for Pipe Handrail, (Material), LF.

INLET TYPE C (MODIFIED)

10/30/2018 8:46:04 AM

LAST REVISION 11/01/17	DESCRIPTION:	 FY 2019-20 STANDARD PLANS	BACK OF SIDEWALK DRAINAGE	INDEX 425-060	SHEET 1 of 3
---------------------------	--------------	----------------------------------------------------------------------------------------------------------------------	---------------------------	------------------	-----------------

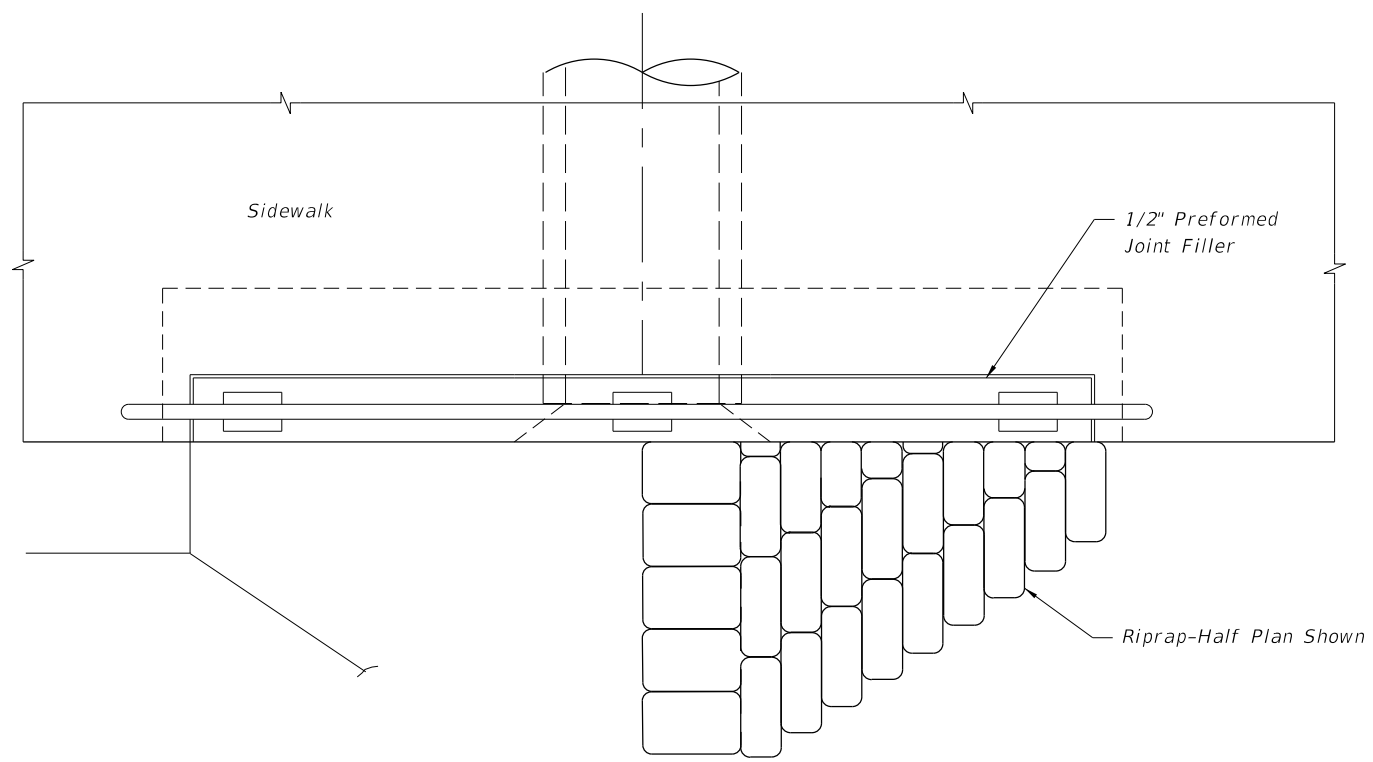

PLAN

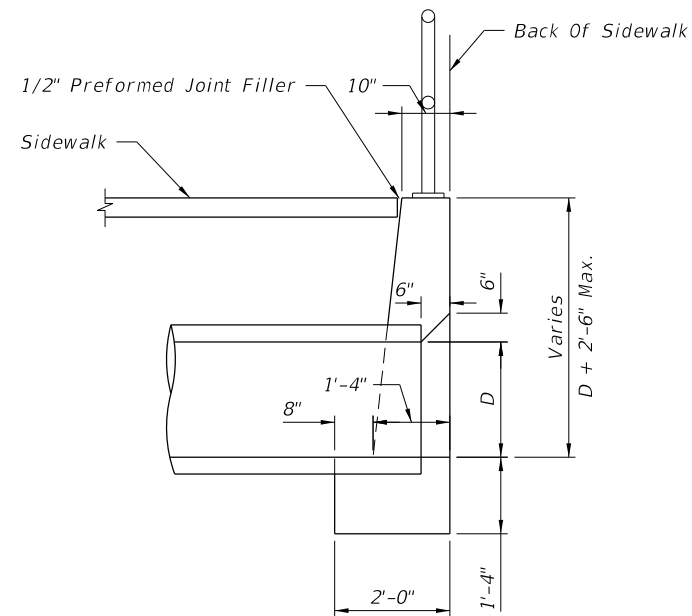

SECTION AA

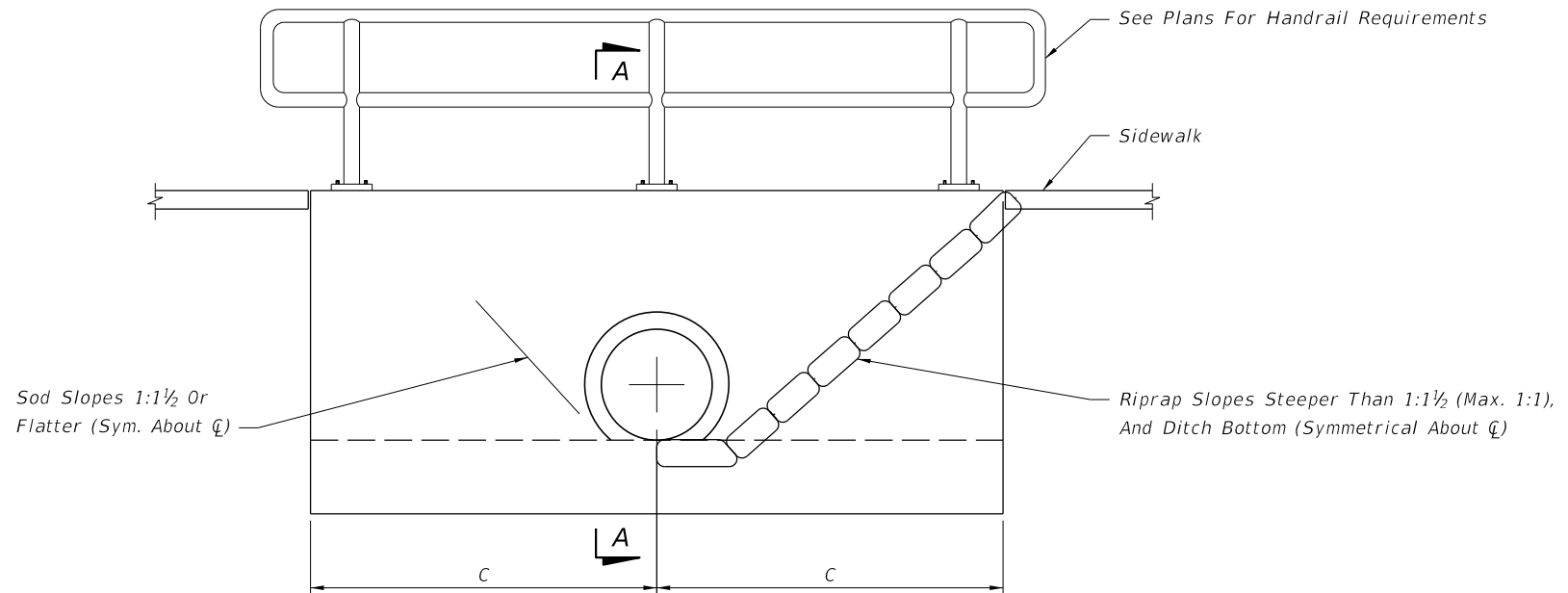

FRONT ELEVATION

- Notes:
1. Maximum pipe size shall be 24" diameter.
 2. Grading back of sidewalk varies and shall be done as directed by the Engineer.
 3. Concrete quantities shown are for maximum wall heights, and shall be basis for estimate and payment.
 4. Riprap quantities shown are for estimate purposes only. Cost of riprap to be included in cost of the endwall.
 5. Endwalls to be paid for under the contract unit price for Concrete Class I (Endwalls), CY. Handrail to be paid for under the contract unit price for Pipe Handrail, (Material), LF.

Pipe Size (in)	C	Concrete Class I (CY)	Sand-Cement Riprap (CY)
15	4'-9"	2.3	1.1
18	5'-3"	2.6	1.3
24	6'-3"	3.3	1.8

SPECIAL CONCRETE ENDWALL

10/30/2018 8:46:08 AM

LAST REVISION	DESCRIPTION:
11/01/17	



FY 2019-20
STANDARD PLANS

BACK OF SIDEWALK DRAINAGE

INDEX
425-060

SHEET
2 of 3

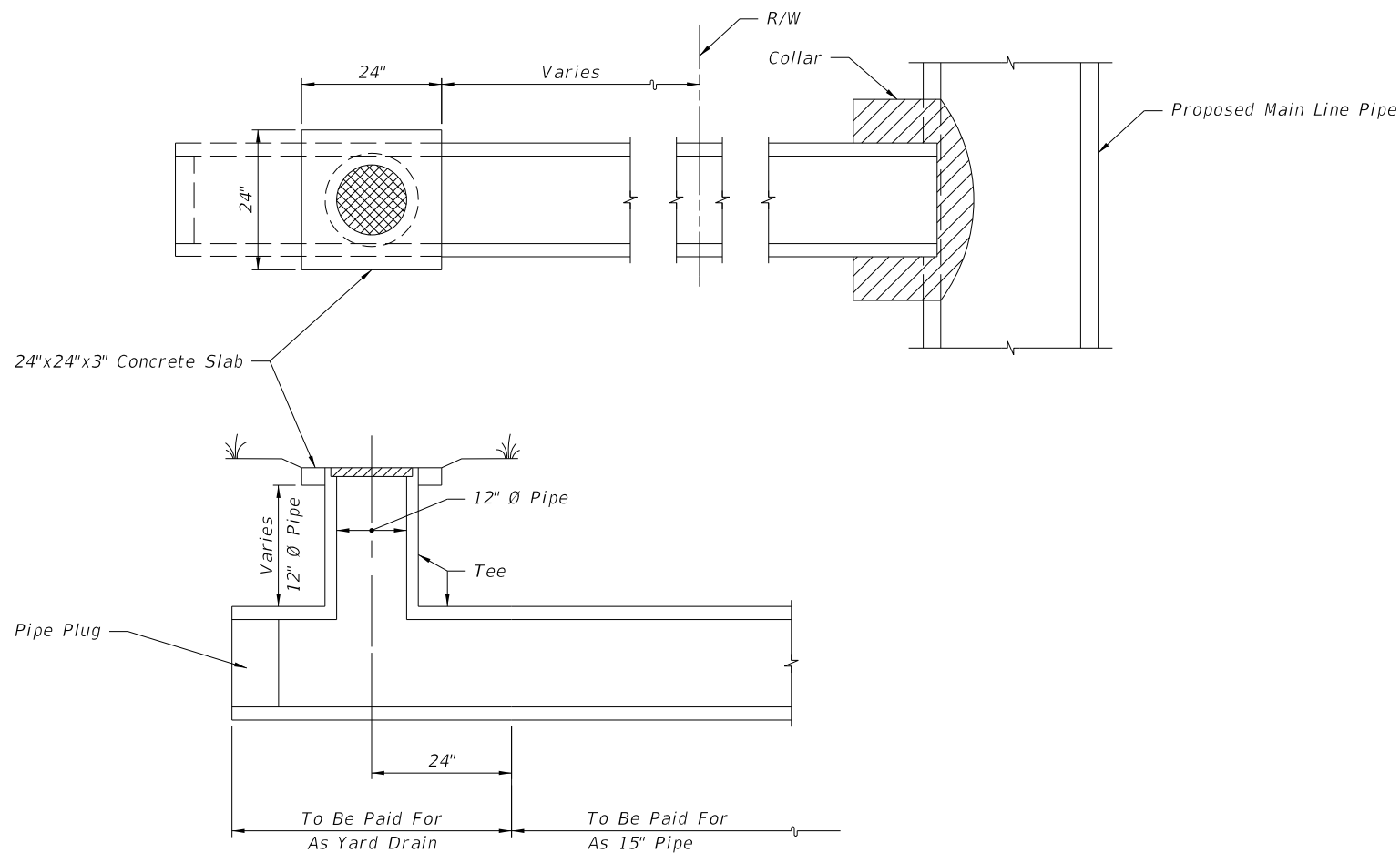

YARD DRAIN ITEM INCLUDES:

1. 15" x 15" x 12" Concrete or PVC Tee 4' long.
2. Grate diameter = 14-1/4"
Thickness = 2-1/2"
Flow area = 45 sq in min.
Light Duty Cast Iron, see Specification Section 962.
3. 12" pipe as necessary.
4. 0.04 Cubic yards concrete for slab.

YARD DRAINS

- Notes:
1. Yard drains to be located outside the R/W. Drainage area should not exceed 750 SF (grate flow 0.1 Cfs).
 2. Yard drains may be constructed at the option of the property owner as shown on the plans.
 3. Cost of plugs and collars to be included in the cost for 15" pipe. For collar and plug details see Index 430-001.
 4. Yard drains to be paid for under the contract unit price for Yard Drains, EA.

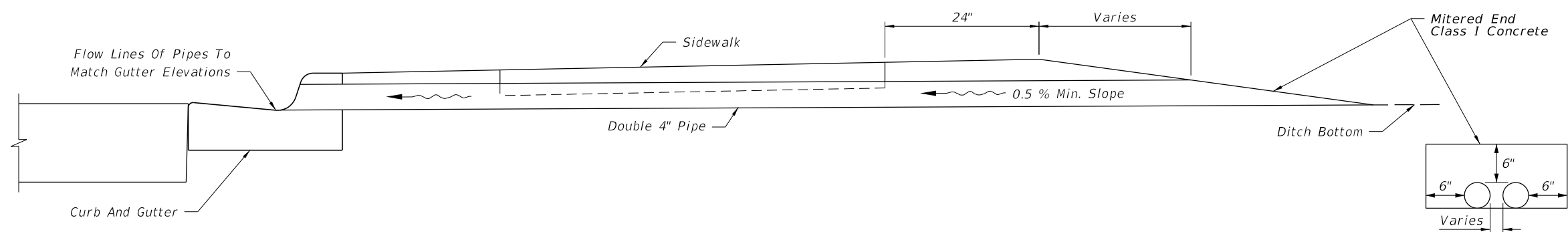

SHALLOW DITCHES

- Notes:
1. To be constructed at locations as directed by the Engineer.
 2. Either cast iron pipe or PVC rigid conduit, U.L. listed for direct sunlight exposure, Schedule 40, may be used.
 3. Pipe and Mitered End to be paid for under the contract unit price for either Cast Iron Soil Pipe (Standard) (4"), LF or PVC Pipe For Back Of Sidewalk Drainage (4"), LF.

Note:
Miter to slope.

10/30/2018 8:46:14 AM

LAST REVISION 11/01/17	DESCRIPTION:	 FY 2019-20 STANDARD PLANS	BACK OF SIDEWALK DRAINAGE	INDEX 425-060	SHEET 3 of 3
---------------------------	--------------	------------------------------------------------------------------------------------------------------------------------------	----------------------------------	------------------	-----------------

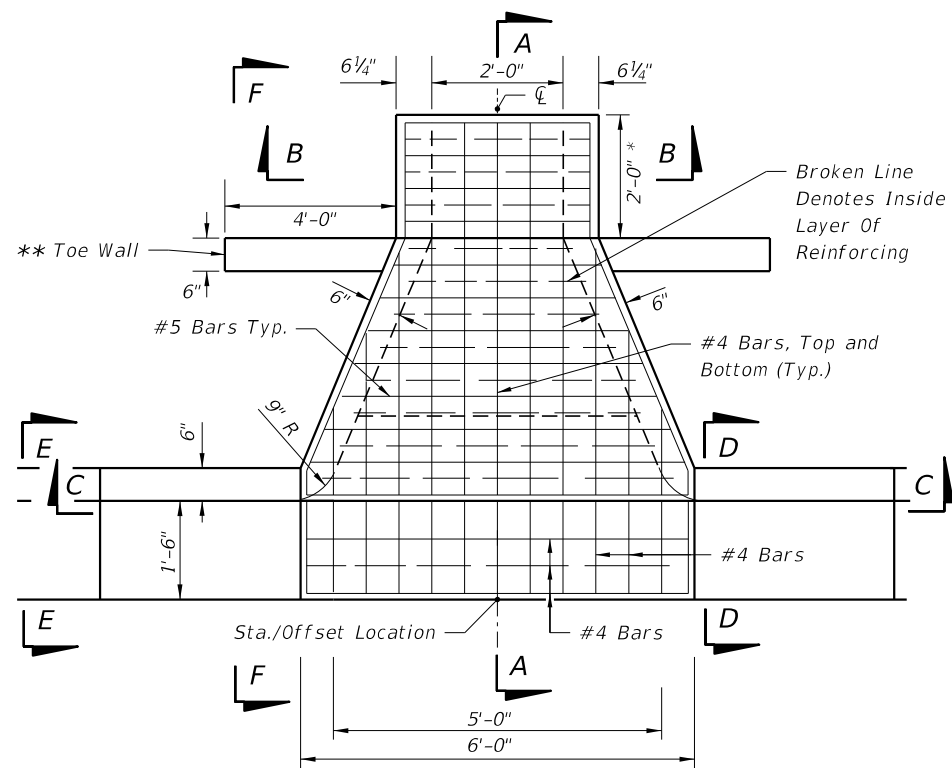

TOP VIEW

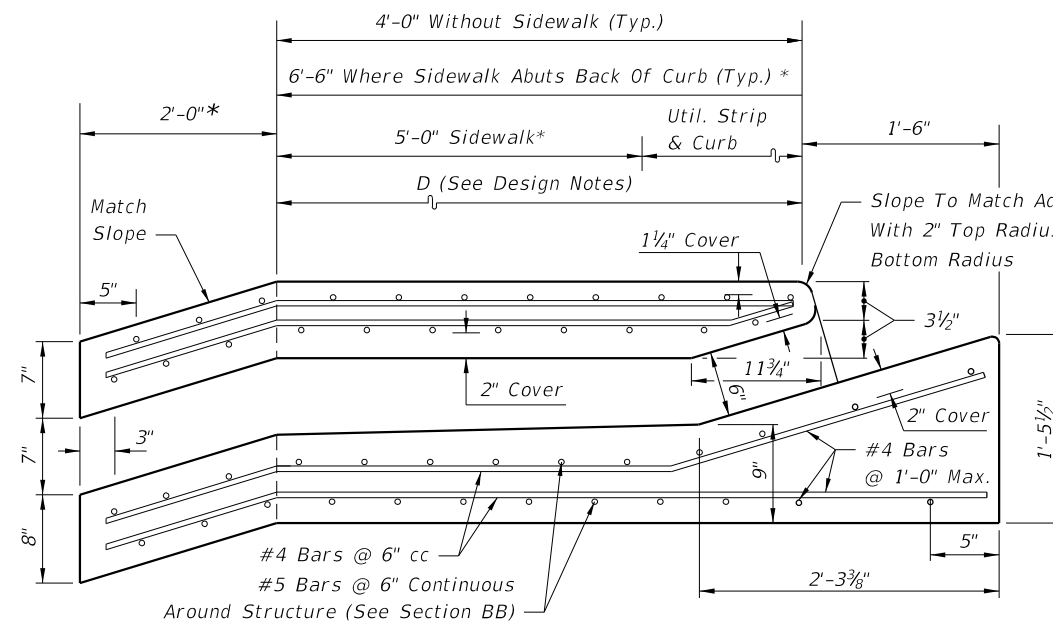

SECTION AA

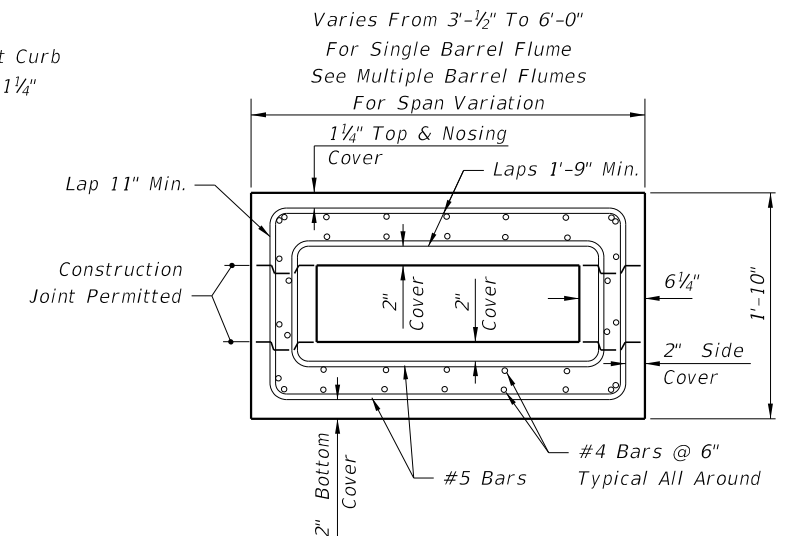

SECTION BB

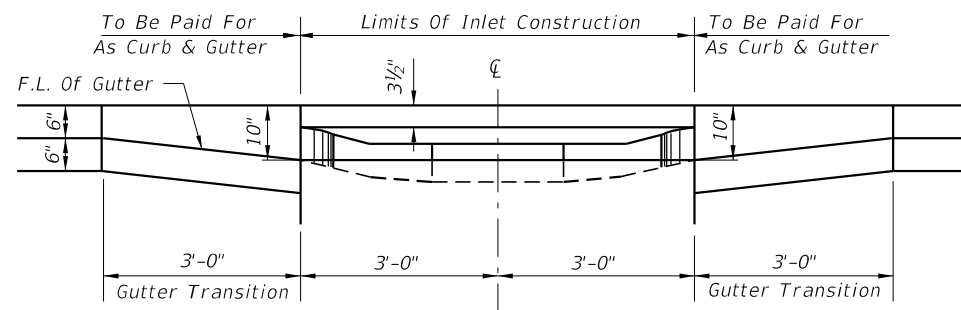

SECTION CC

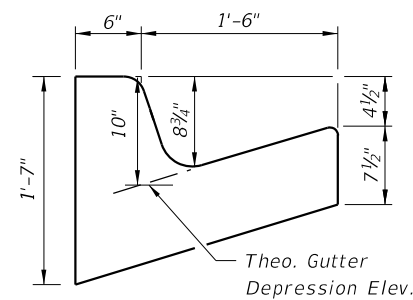

SECTION DD

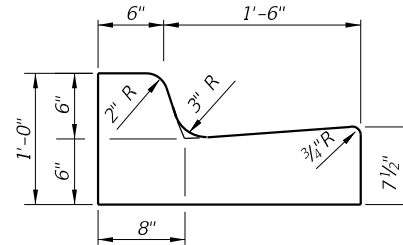

SECTION EE
(Curb And Gutter Type F)

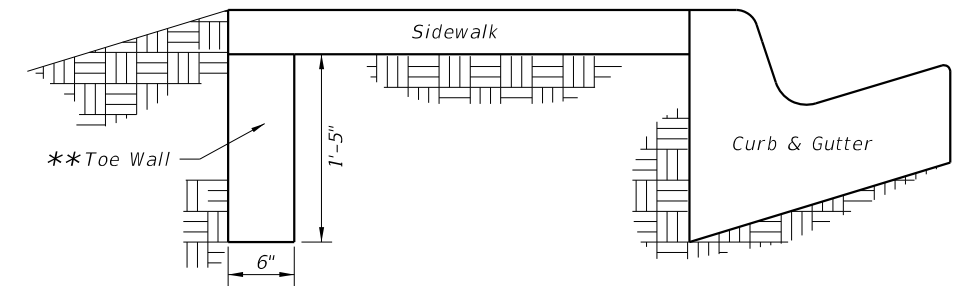

SECTION FF

* Sloped Section to be used w/sidewalk applications only.
 ** Toe Walls as depicted to be used with sidewalk application only. For endwall without sidewalk see detail on Sheet 2.

DESIGN NOTES

1. These inlets are designed for use with Type F curb and gutter only. Locate inlet outside of curb ramp area.
 The Single Barrel Flume is intended for locations with light to moderate flows. Multiple Barrel Flumes must be selected to meet design heavy flows.
2. Designer must specify Flume Type, "D" dimension, number of barrels and guiderail requirements in plans.
3. Designer must specify where energy dissipating bricks are required.

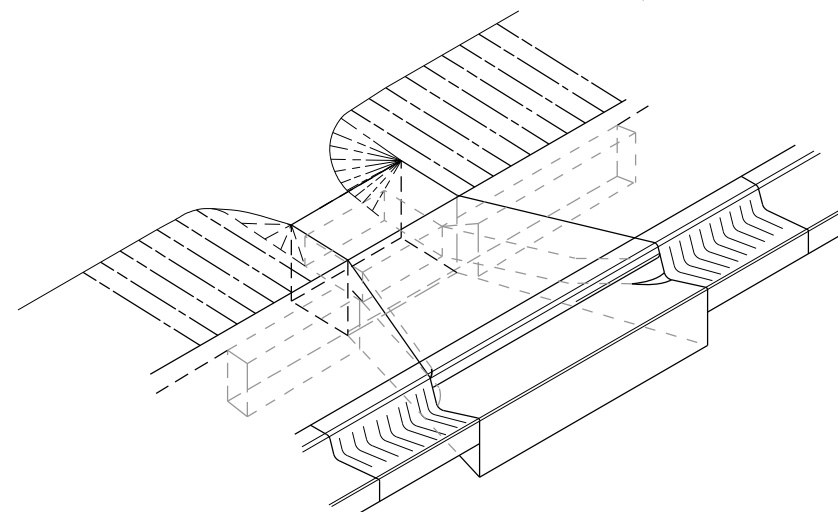

FLUME W/SIDEWALK INLET (CLOSED FLUME) TYPE I
 SINGLE BARREL FLUME DEPICTED

GENERAL NOTES

1. The finished grade and slope of the inlet top are to conform with the finished cross slope and grade of the proposed sidewalk and/or border.
2. When inlets are to be constructed on a curve, refer to the plans to determine the radius and, where necessary, modify the inlet details accordingly. Bend steel when necessary.
3. All steel shall have 2" minimum cover unless otherwise shown. Inlets can be either cast-in-place or precast concrete. Chamfer all exposed edges 3/4".
4. All reinforcement is ASTM A615/A615M Grade 60 steel, either smooth or deformed. Equivalent area grade 40 steel or 65 ksi welded wire fabric may be substituted.
5. Inlets to be paid for under the contract unit price for Inlets (Closed Flume) EA.

10/30/2018 8:46:18 AM

LAST REVISION 11/01/17	REVISION	DESCRIPTION:		FY 2019-20 STANDARD PLANS	CLOSED FLUME INLET	INDEX 425-061	SHEET 1 of 3
---------------------------	----------	--------------	--	------------------------------	--------------------	------------------	-----------------

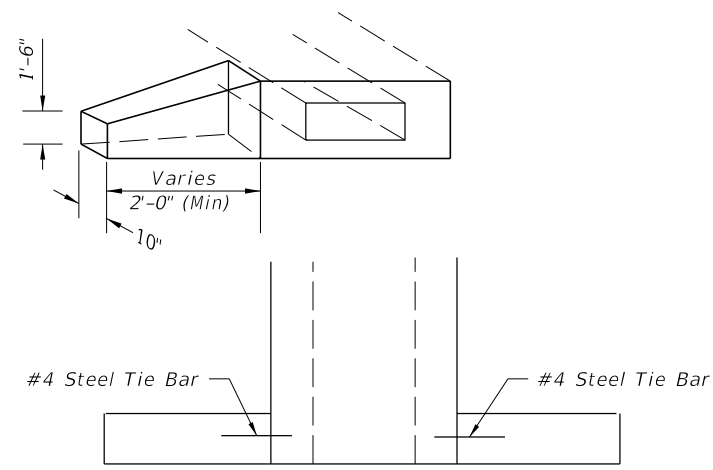

ENDWALL

*Bricks to Dissipate Energy
When Called For In Plans.
Bricks To Be Included In
The Cost Of The Inlet.

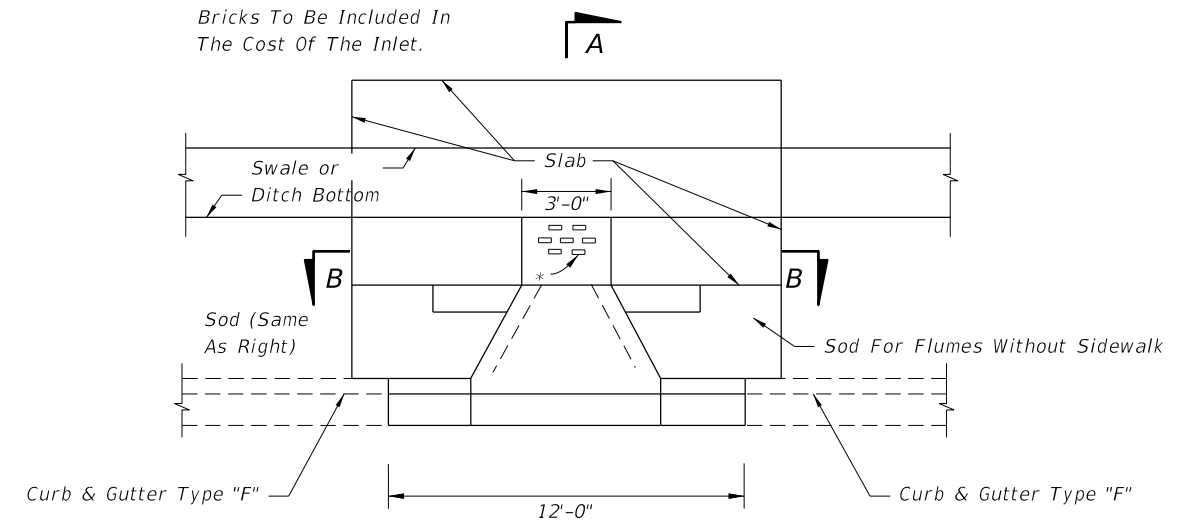

PLAN

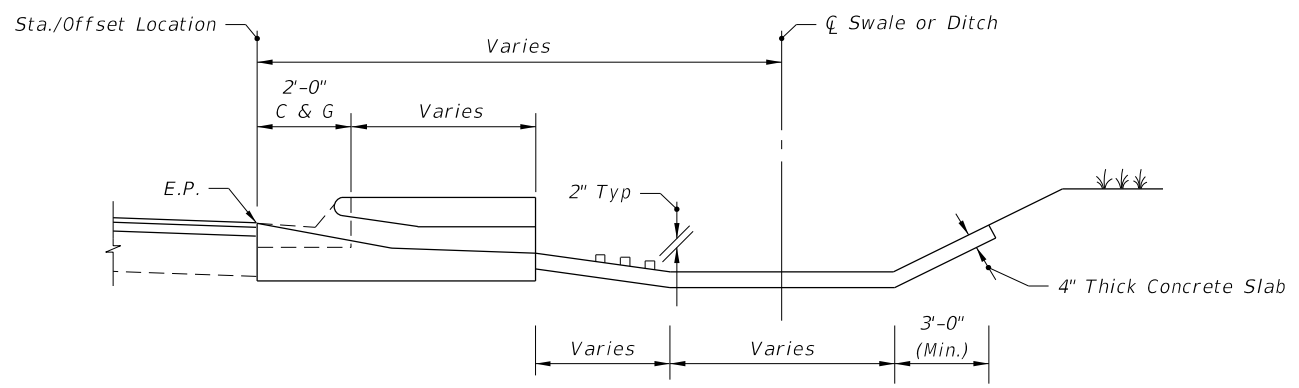

SECTION AA

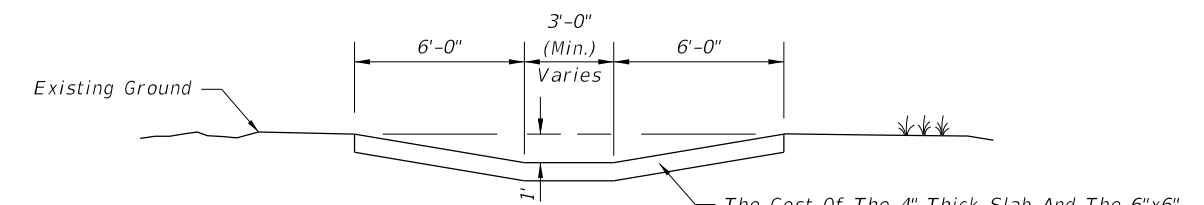

SECTION BB

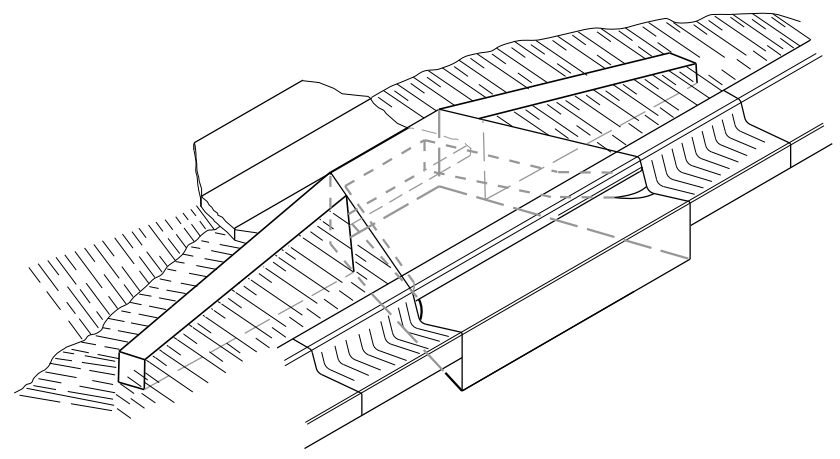

FLUME W/O SIDEWALK INLET (CLOSED FLUME) TYPE II
SINGLE BARREL FLUME DEPICTED

10/30/2018 8:46:22 AM

LAST REVISION 11/01/17	REVISION	DESCRIPTION:		FY 2019-20 STANDARD PLANS	CLOSED FLUME INLET	INDEX 425-061	SHEET 2 of 3
---------------------------	----------	--------------	--------------------------------------------------------------------------------------	------------------------------	--------------------	------------------	-----------------

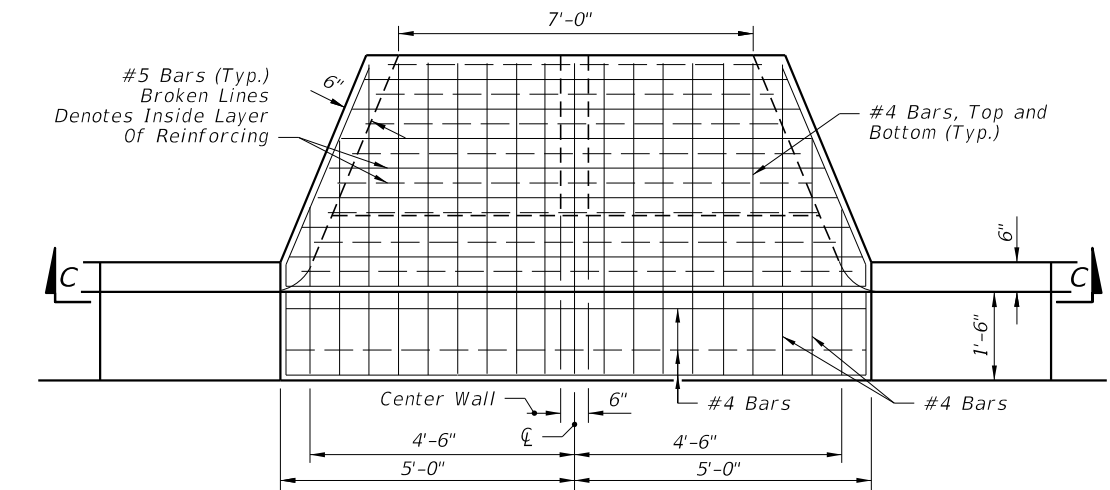

TOP VIEW

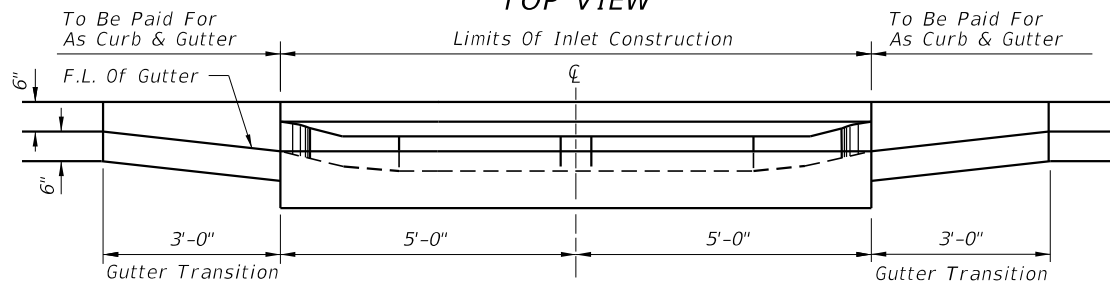

SECTION CC

DOUBLE BARREL FLUME

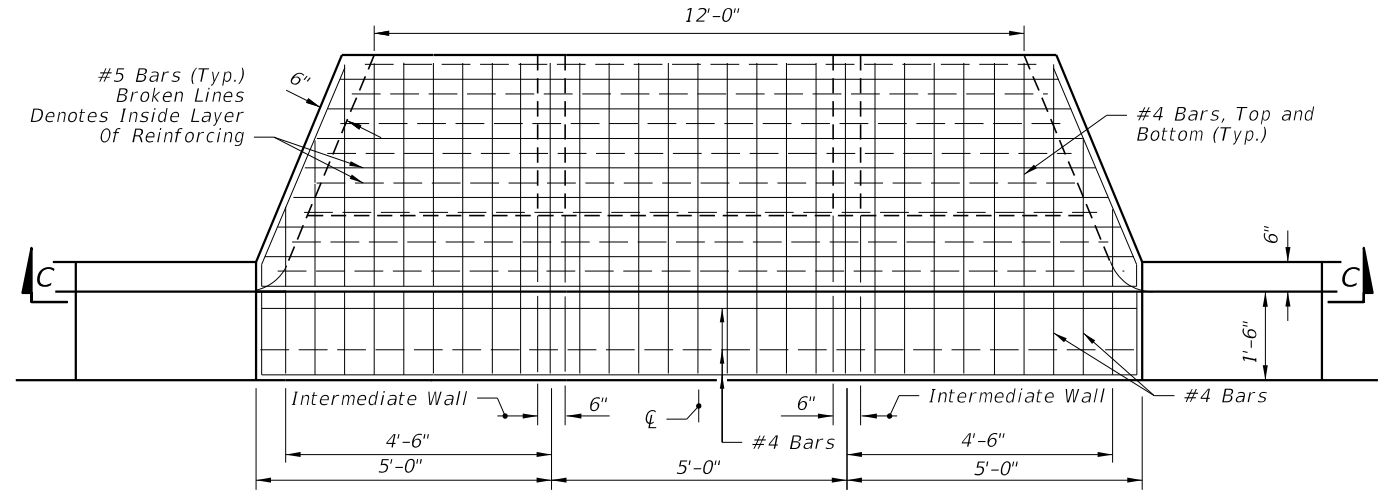

TOP VIEW

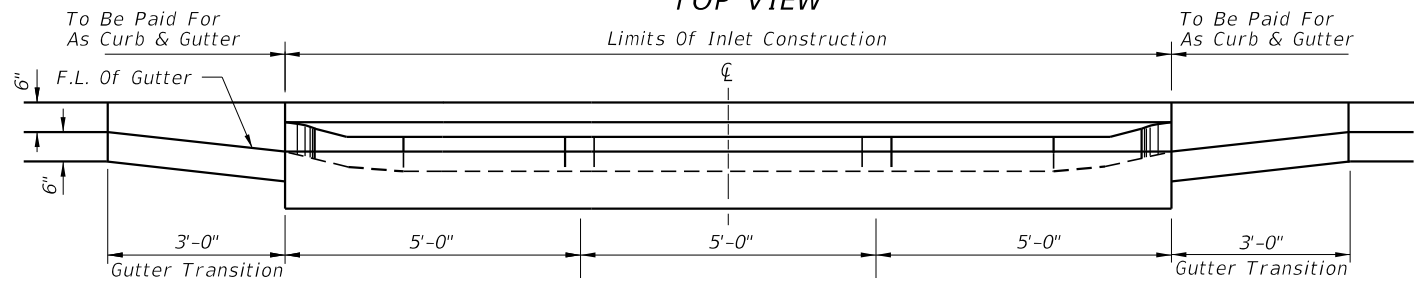

SECTION CC

TRIPLE BARREL FLUME

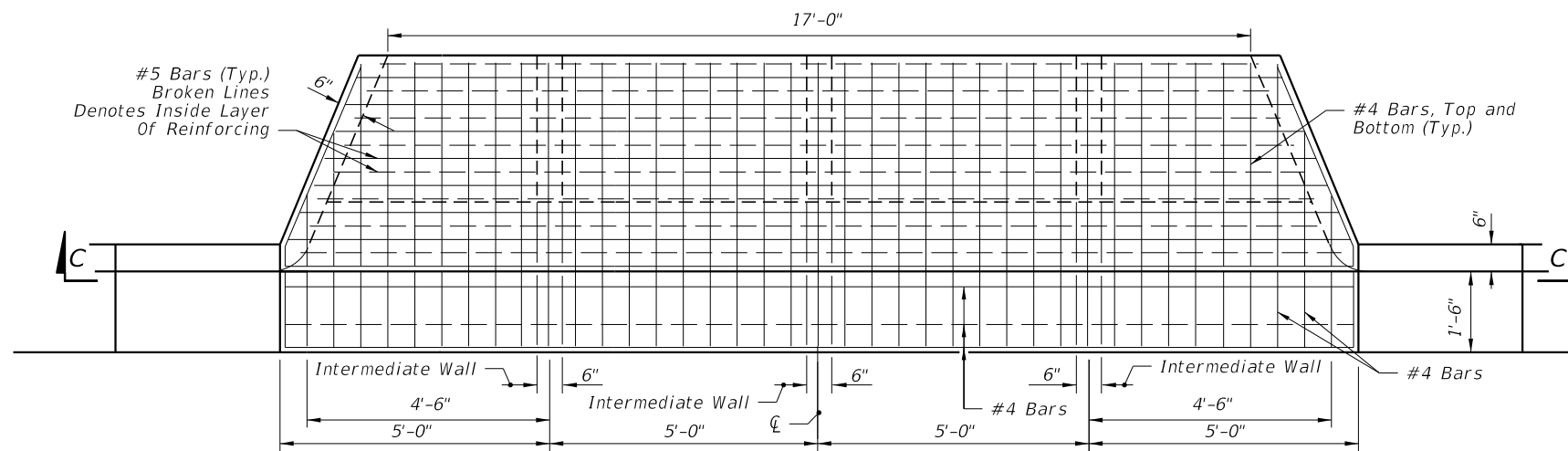

TOP VIEW

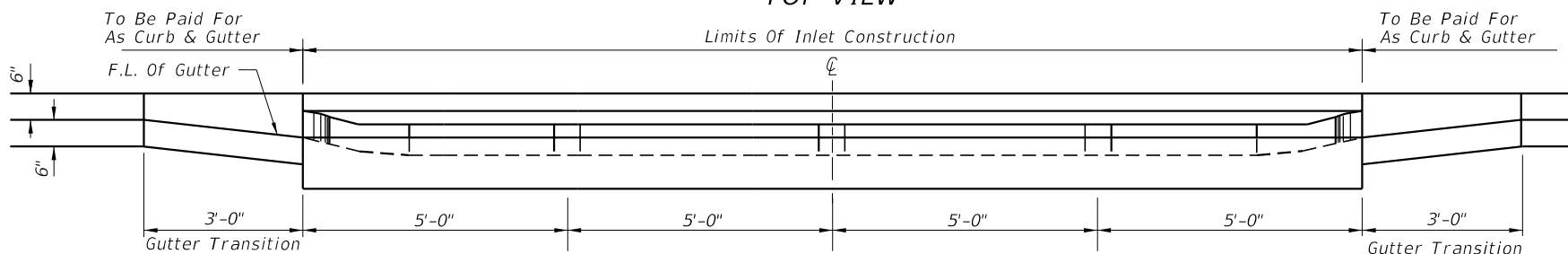

SECTION CC

QUADRUPLE BARREL FLUME

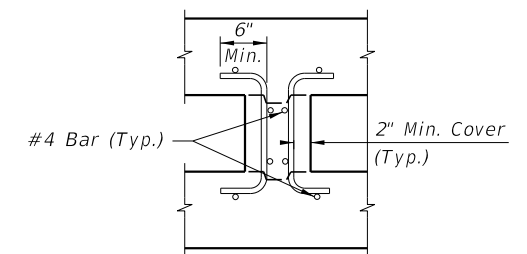

INTERMEDIATE-WALL REINFORCING

NOTE: See Barrel Flume For Base Dimensions.

10/30/2018 8:46:25 AM

LAST REVISION 11/01/17	DESCRIPTION:
---------------------------	--------------

**FY 2019-20
STANDARD PLANS**

CLOSED FLUME INLET

INDEX 425-061	SHEET 3 of 3
------------------	-----------------

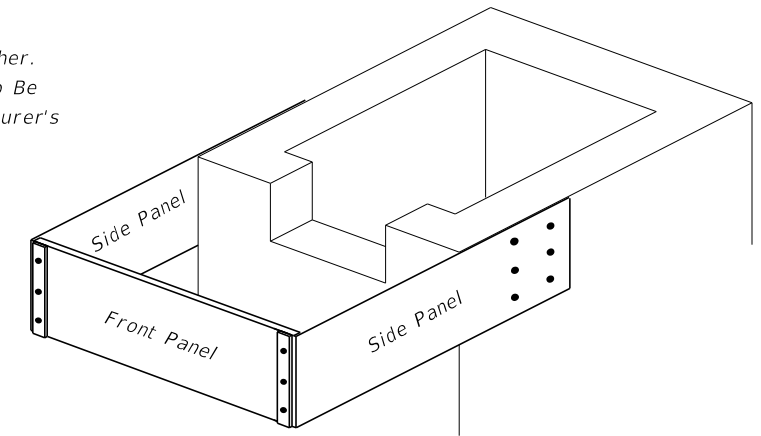
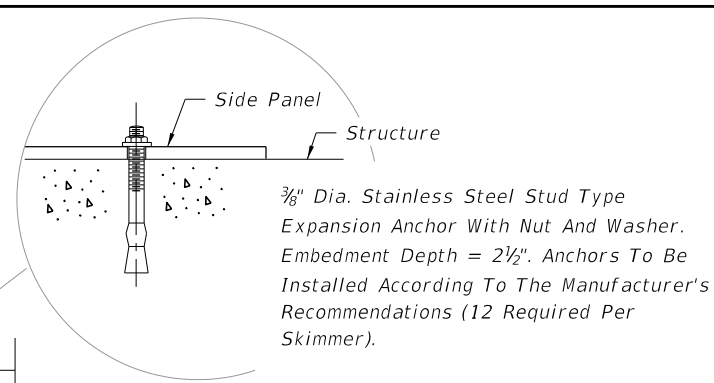
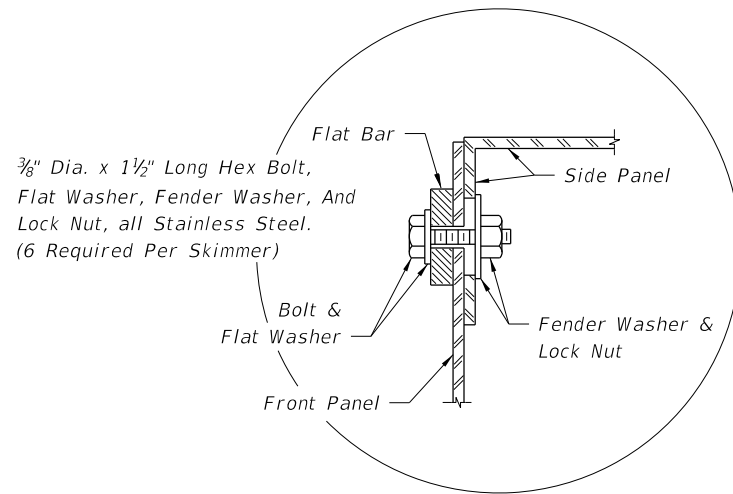

PICTORIAL VIEW

GENERAL NOTES

1. This skimmer is intended for use on Type C, D, or E Ditch Bottom Inlets that are used as outlet control structures of stormwater management facilities.
2. The side panels are dimensionally symmetric, therefore they may be used on either side of the structure.
3. Two (2) skimmers may be constructed on one structure provided they are on opposite ends.
4. The width of the front panel (dimension W) shall be the same as the outside dimension across the front of the structure.
5. The front panel, side panels, and flat bars are to be hot dip galvanized after fabrication.
6. The location of the reinforcing steel in these structures must conform to the applicable standards to avoid conflict with the expansion anchors used to attach the skimmer.
7. Grates to be used on the inlets unless otherwise specified in the plans.
8. A skimmer consists of two (2) side panels, one front panel, two (2) flat bars, and accessory hardware. The cost of skimmers is to be included in the cost of the inlet.

DESIGN NOTES

1. The designer must specify, in the plans, the skimmer height (dimension H) and the sides where the weir slots and skimmers are located. The skimmer height must be one of the dimensions shown in the table on Sheet 2. The skimmer should not be used on structure sides with outside dimensions greater than 6'-4".
2. To minimize hydraulic losses across the skimmer, the flow area under the skimmer should be three times larger than the flow area of the weir slot. The distance between the pond bottom at the structure and the skimmer shall be not less than 1 foot.
3. The configuration of skimmers may be subject to regulatory requirements. The designer should coordinate the outlet control structure details with the permitting agencies.
4. Where this skimmer is used, the designer should reference this index with the outlet control structure details. Where a different skimmer design is needed, the designer should provide skimmer details in the plans.
5. The designer shall evaluate if a grate is needed for safety reasons. Where a grate is not needed for safety reasons and is not desirable for hydraulic or other reasons, the designer may omit the grate by stating so in the outlet control structure details.
6. The designer must show the configuration of the weir slots in the outlet control structure detail.

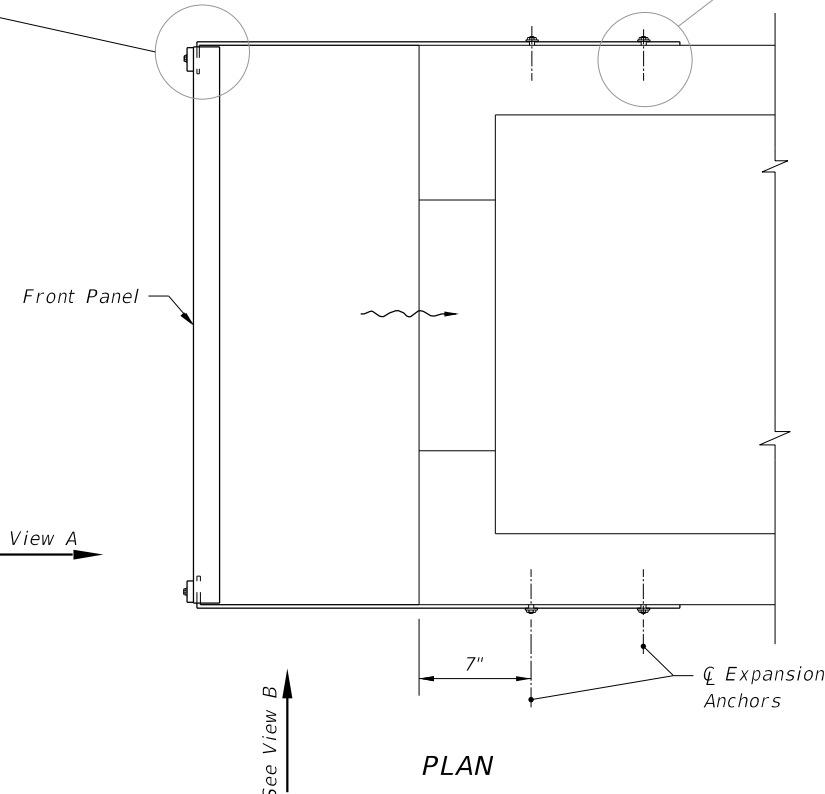

PLAN

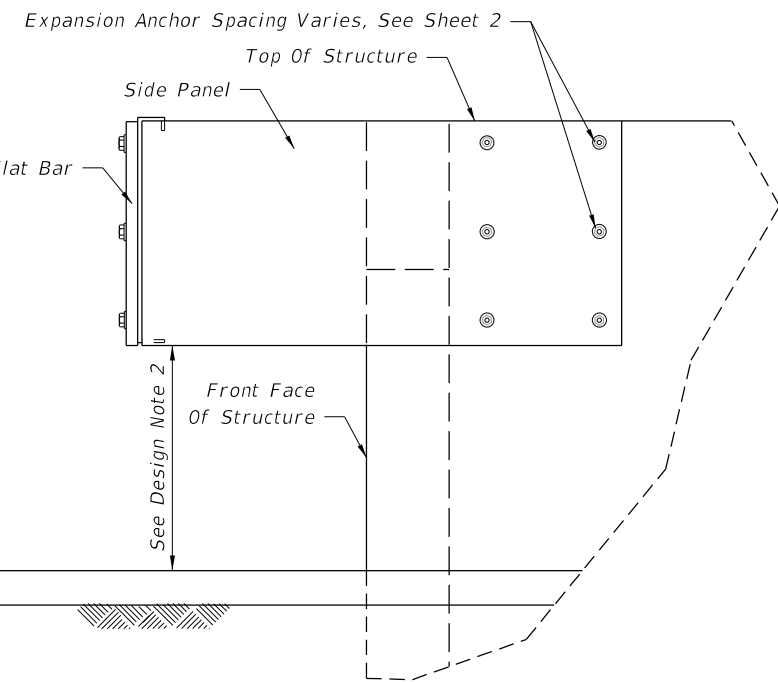

SIDE VIEW

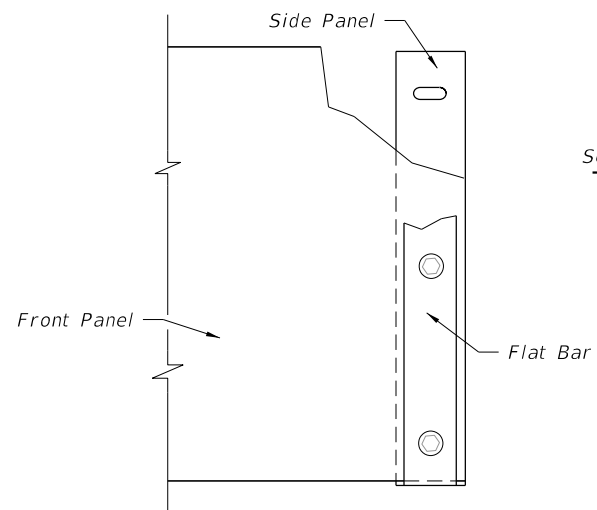

VIEW A

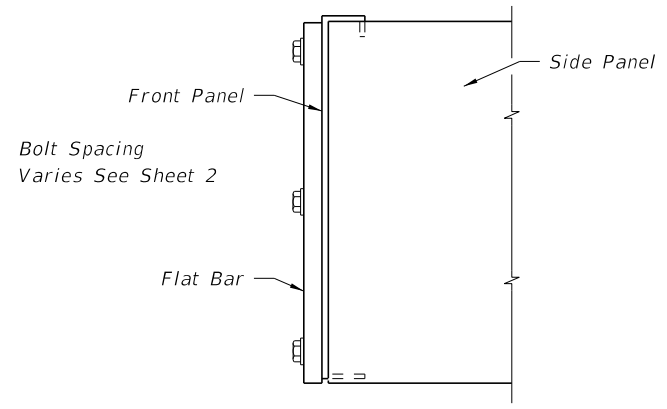

VIEW B

10/30/2018 8:46:30 AM

LAST REVISION 11/01/17	REVISION	DESCRIPTION:	 FY 2019-20 STANDARD PLANS	SKIMMER FOR OUTLET CONTROL STRUCTURES	INDEX 425-070	SHEET 1 of 2
---------------------------	----------	--------------	----------------------------------	---------------------------------------	------------------	-----------------

DIMENSIONS				
Skimmer Height as Specified in the Plans				Bolt Spacing
H	D	E	L	S
Inches				
12	3 ³ / ₁₆	3	28	3
14	3 ³ / ₁₆	3	28	4
16	3 ³ / ₁₆	3	28	5
18	3 ³ / ₁₆	3	28	6
20	4 ³ / ₁₆	4	31	6
22	4 ³ / ₁₆	4	31	7
24	4 ³ / ₁₆	4	31	8
26	4 ³ / ₁₆	4	31	9
28	4 ³ / ₁₆	4	31	10
30	5 ³ / ₁₆	5	31	10
32	5 ³ / ₁₆	5	31	11
34	5 ³ / ₁₆	5	31	12
36	6 ³ / ₁₆	6	31	12
38	6 ³ / ₁₆	6	31	13
40	6 ³ / ₁₆	6	31	14

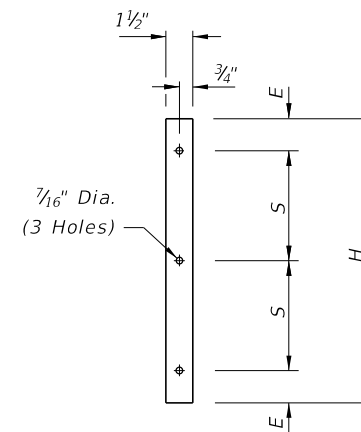

1/4" Thick x 1 1/2" Wide
FLAT BAR

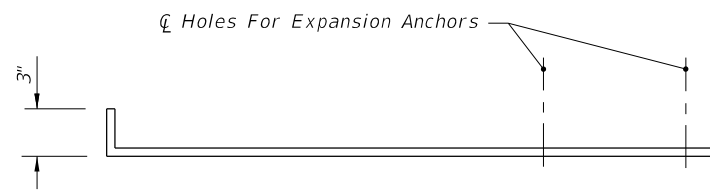

TOP VIEW

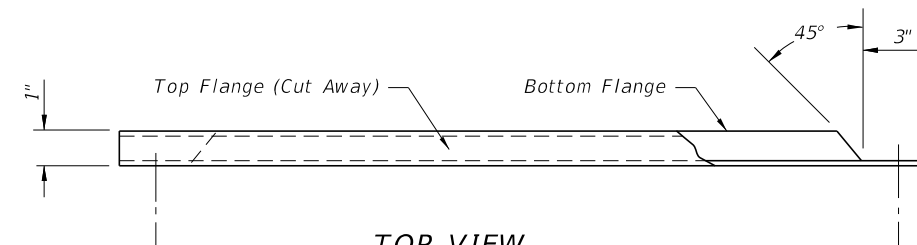

TOP VIEW

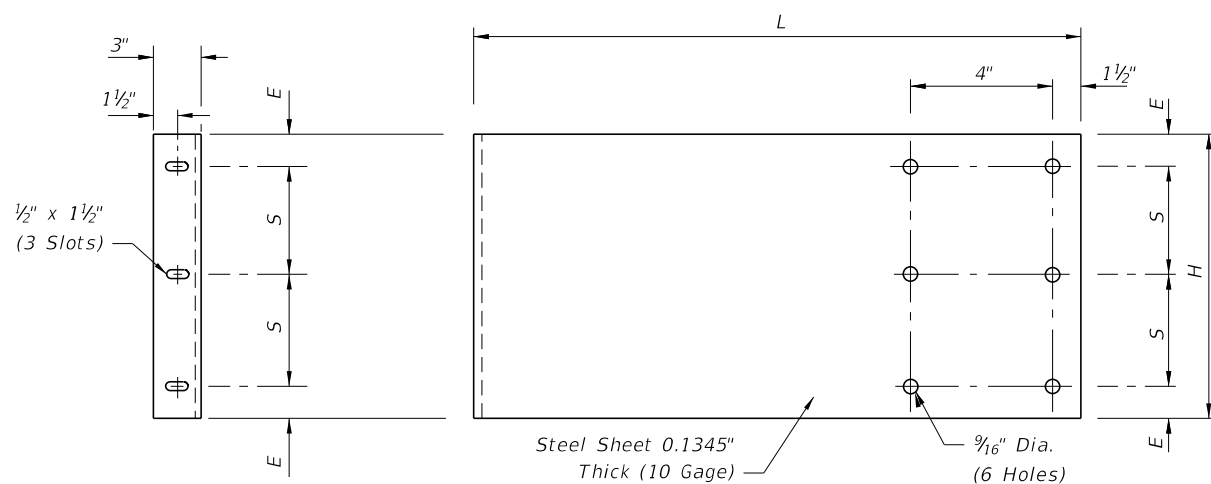

END VIEW (FRONT)

SIDE VIEW

SIDE PANEL

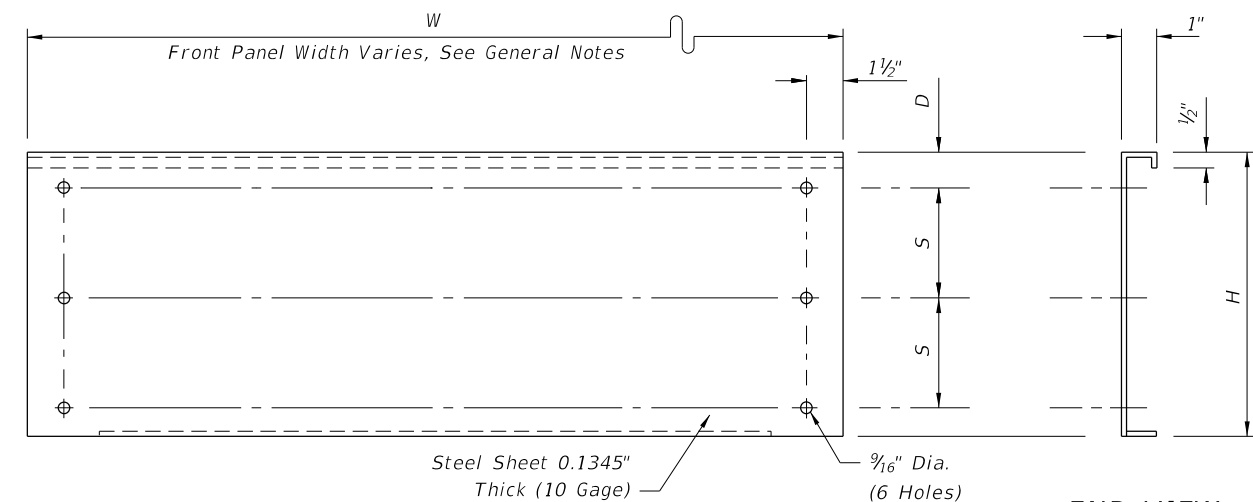

FRONT VIEW

END VIEW

FRONT PANEL

10/30/2018 8:46:33 AM

LAST REVISION 11/01/17	DESCRIPTION:
---------------------------	--------------



FY 2019-20
STANDARD PLANS

SKIMMER FOR OUTLET CONTROL STRUCTURES

INDEX
425-070

SHEET
2 of 2

NOTES:

1. These details are for construction field expediency to resolve utility conflicts that cannot be remedied by relocation. For conflicts determined during design, use the construction shop drawings for structure details.
2. Concrete used in conflict structures shall be as specified in ASTM C478. 4000 psi may be used in lieu of Class I concrete.
3. Maximum opening for pipe shall be the pipe OD plus 6". Mortar used to seal the pipe into the opening will be of such mix that shrinkage will not cause leakage into or out of the structure.
4. If the conflict structure is round or there are multiple inlet or outlet pipes, then the wall section should be reviewed for strength.
5. If during construction or the plans design process it is determined that a potable water supply line must pass through a storm drain structure, it must be in compliance with Chapter 62-555.314 (3) F.A.C. and shown on the design or construction plans and submitted to the Florida Department of Environmental Protection (FDEP) Administrator For Drinking Water in the respective FDEP District for review and comment. This index and rule citation provide accepted methods for addressing conflicts when and where they cannot be reasonably avoided. To be submitted along with the plans shall be a justification describing inordinate cost and the impracticality of avoidance. If identified, properly justified, and accomplished in accordance with this index, approval is granted. Upon request, the Utility Agency Owner (UAO) must provide support data on the cost of relocation or adjustment to the FDOT for submittal to the FDEP. See the following web site for District FDEP Drinking Water Contacts: www.dep.state.fl.us/water/drinkingwater/index.htm and click on "Organization" on the menu to the right.

DESIGNER'S NOTES:

"Sumped" conflict manholes shall not be used unless the system is hydraulically designed to account for the headloss generated if the sump is completely blocked

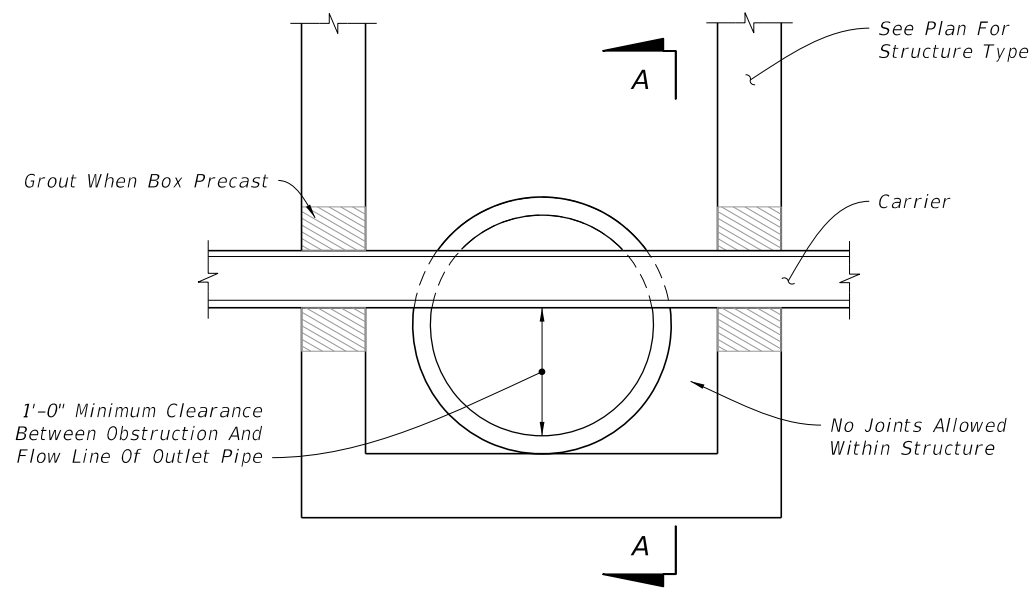

SECTION LONGITUDINAL TO CARRIER PIPE

UTILITY CONFLICT CONDITION I

(Nonpressure Or Nonfluid Carrier Installations)

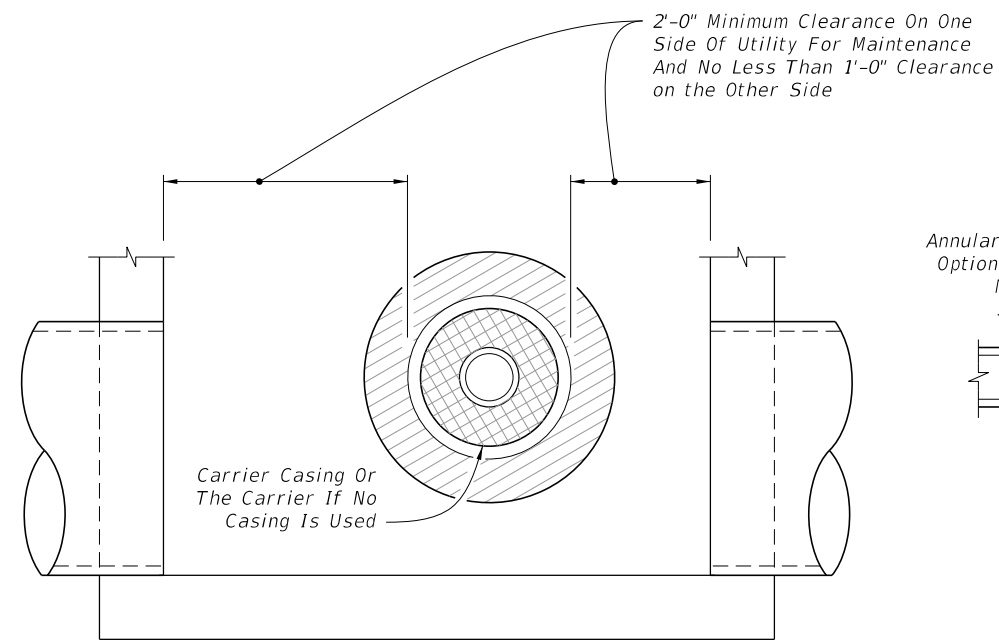

SECTION A-A

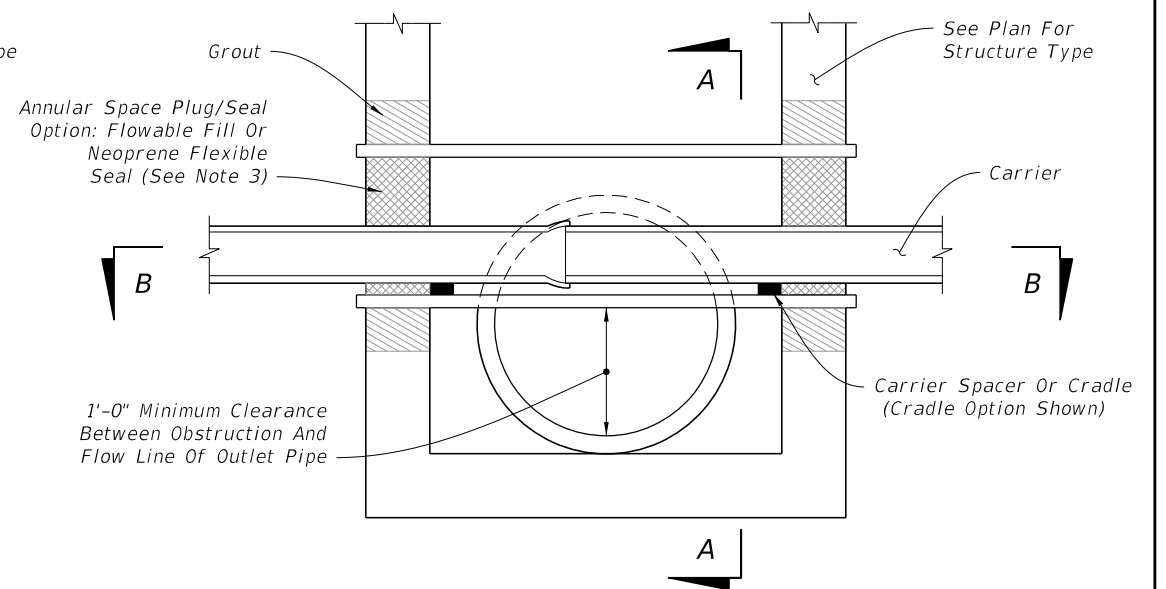

SECTION LONGITUDINAL TO CARRIER PIPE

UTILITY CONFLICT CONDITION II

(Pressure Or Fluid Carrier Installations)

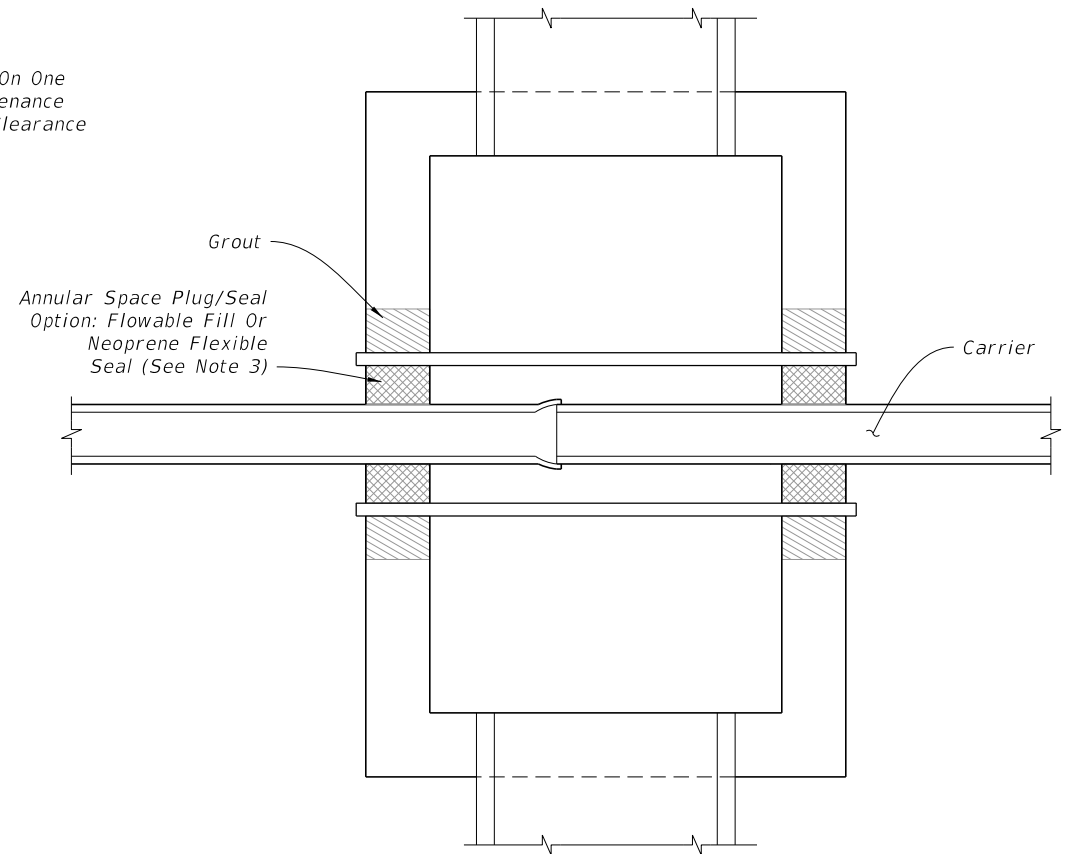

SECTION B-B

UTILITY CONFLICT PIPES THRU STORM DRAIN STRUCTURES

10/30/2018 8:46:39 AM

LAST REVISION 11/01/17	DESCRIPTION:	 FY 2019-20 STANDARD PLANS	UTILITY CONFLICTS THRU DRAINAGE STRUCTURES	INDEX 425-080	SHEET 1 of 1
---------------------------	--------------	-----------------------------------------------------------------------------------------------------------------------	--------------------------------------------	------------------	-----------------

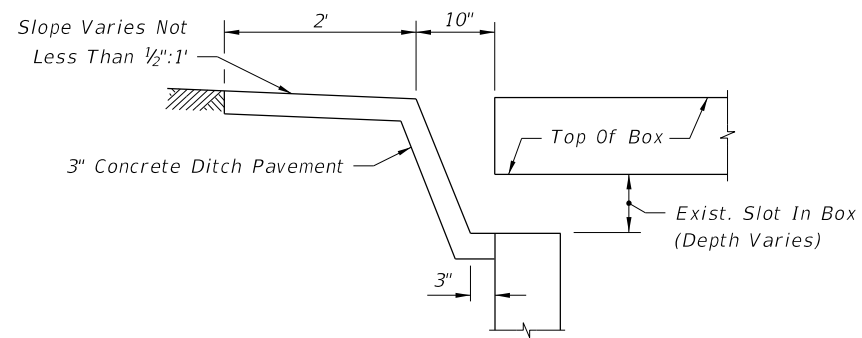

LONGITUDINAL SECTION

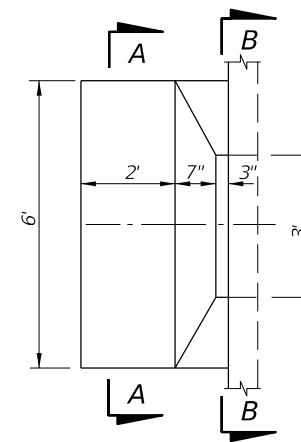

PLAN

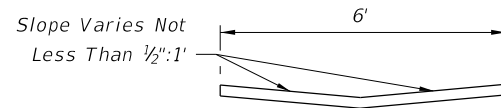

SECTION AA

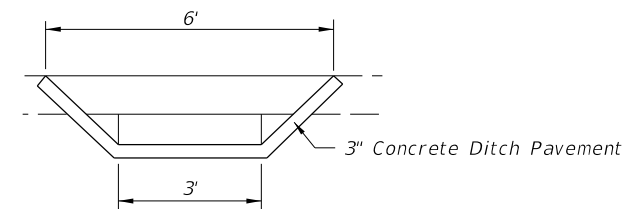

SECTION BB

SAFETY MODIFICATION FOR INLETS IN BOX CULVERTS

10/30/2018 8:46:45 AM

LAST REVISION 11/01/17	REVISION DESCRIPTION:	 FY 2019-20 STANDARD PLANS	SAFETY MODIFICATIONS FOR INLET IN BOX CULVERTS	INDEX 425-090	SHEET 1 of 1
---------------------------	-----------------------	--------------------------------------------------------------------------------------------------------------------	---------------------------------------------------	------------------	-----------------

SCHEDULE OF BELL REINFORCEMENT
Classes II,III,IV,V; Wall A,B,C

Nominal Pipe Diameter	Design Bell Reinforcement in ² per foot	Maximum Reinforcement Under Tolerance in ² per foot
15"	0.07	0.010
18"	0.07	0.010
24"	0.09	0.010
30"	0.12	0.010
36"	0.14	0.010
42"	0.16	0.010
48"	0.19	0.011
54"	0.21	0.012
60"	0.23	0.0135
66"	0.26	0.015
72"	0.28	0.0165
78"	0.30	0.018
84"	0.33	0.0195
90"	0.35	0.021
96"	0.37	0.0225
102"	0.40	0.024
108"	0.42	0.0255

Allowable Tolerance For Last Full Wrap Of Reinforcing When Using Single Elliptical Cage

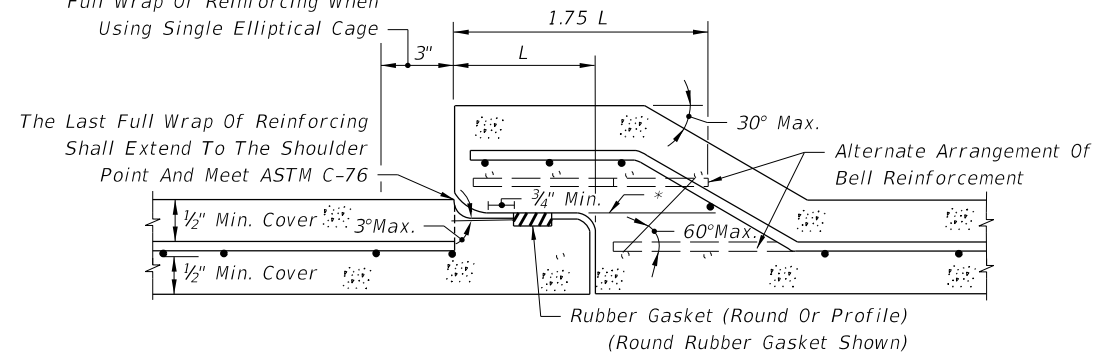

* All circumferential steel located above this line within 1.75 L is defined as bell reinforcement.

**ROUND RUBBER GASKET SHOWN
DETAIL OF BELL & SPIGOT CONCRETE PIPE JOINT
USING ROUND OR PROFILE RUBBER GASKET**

Collar Of Class NS Concrete (May Be Formed By Any Method Approved By The Engineer)

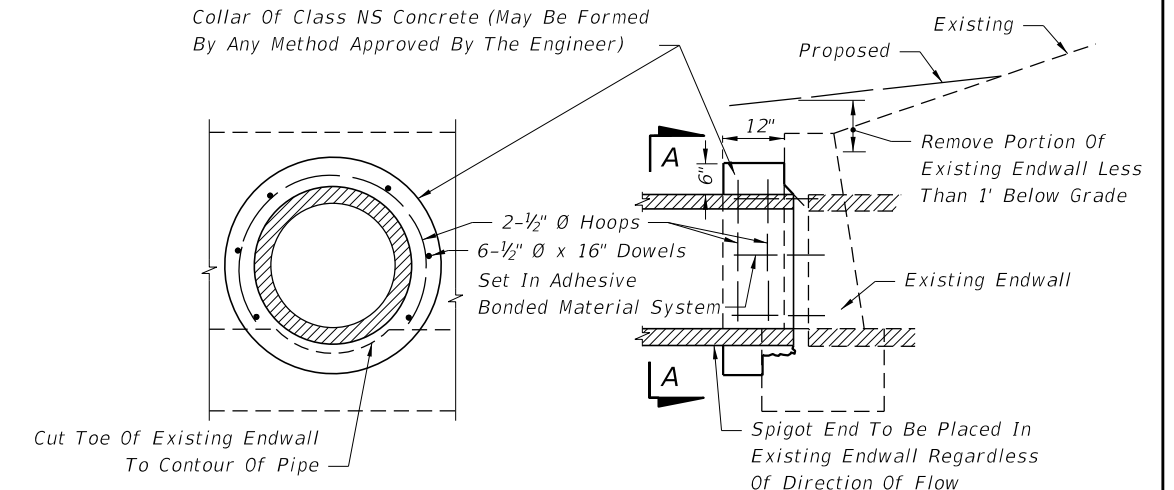

SECTION AA

LONGITUDINAL SECTION

Note: Cost for removal and disposal of portions of top and toe of existing endwall and cost of concrete, reinforcing steel and construction of collar to be included in the contract unit price for pipe culvert.

CONCRETE COLLAR FOR EXTENSION OF EXISTING PIPE CULVERTS

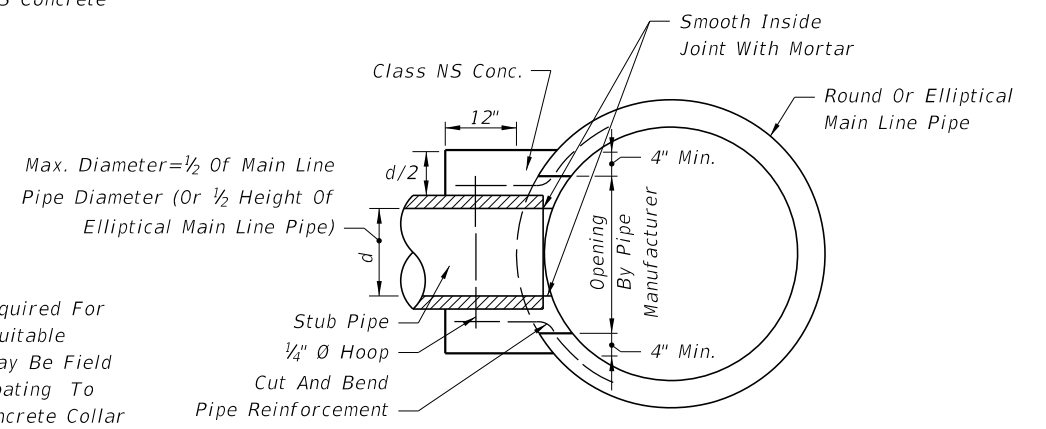

Cost of concrete and steel to be included in contract unit price for pipe culvert.

CONCRETE COLLAR FOR JOINING MAINLINE PIPE AND STUB PIPE

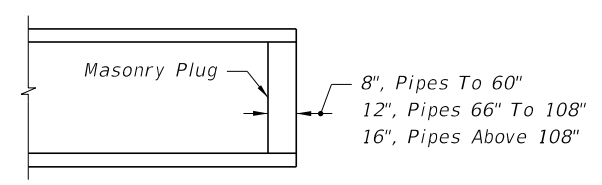

Note: Unless otherwise called for in the plans, the cost of plugging pipes to be included in contract unit price for new pipe.

PIPE PLUG

12" For Pipes 14"x23" Through 19"x30"
24" For Pipes 24"x38" And Larger

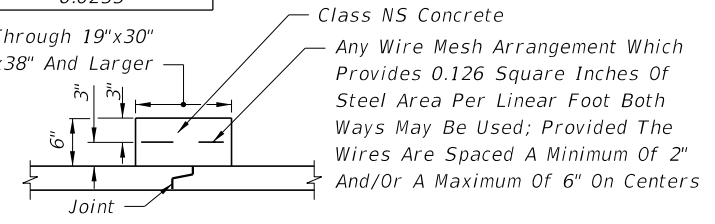

CONCRETE JACKET

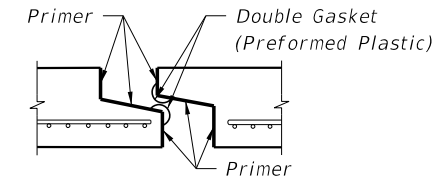

Filter Fabric Jacket Required
PREFORMED PLASTIC JOINT (BEFORE PULL-UP)

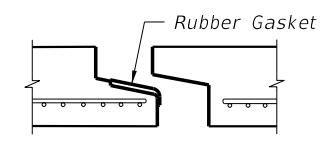

Filter Fabric Jacket Required
PROFILE RUBBER GASKET (BEFORE PULL-UP)

Cost of concrete jacket or filter fabric jacket to be included in cost of elliptical concrete pipe culverts.

ELLIPTICAL CONCRETE PIPE JOINTS

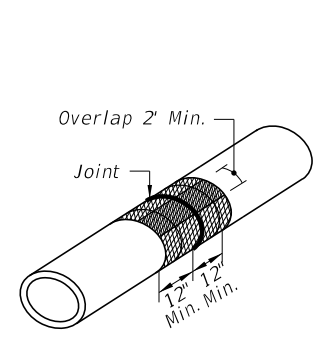

ELLIPTICAL PIPE SHOWN ISOMETRIC VIEW

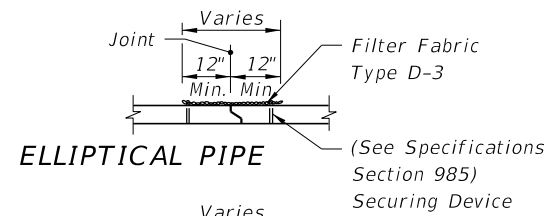

ELLIPTICAL PIPE

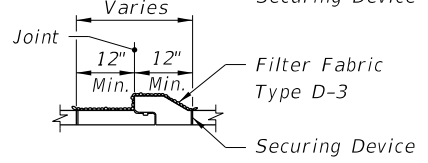

ROUND PIPE PIPE SECTIONS

Cost of filter fabric jacket to be included in cost of pipe culverts.
FOR ALL PIPE TYPES - CONCRETE PIPE SHOWN FILTER FABRIC JACKET

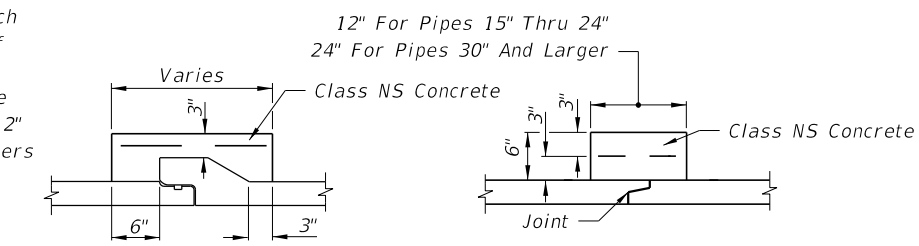

Note: For reinforcement see elliptical pipe concrete jacket. (All Pipe Sizes)
BELL AND SPIGOT TONGUE & GROOVE DISSIMILAR JOINTS

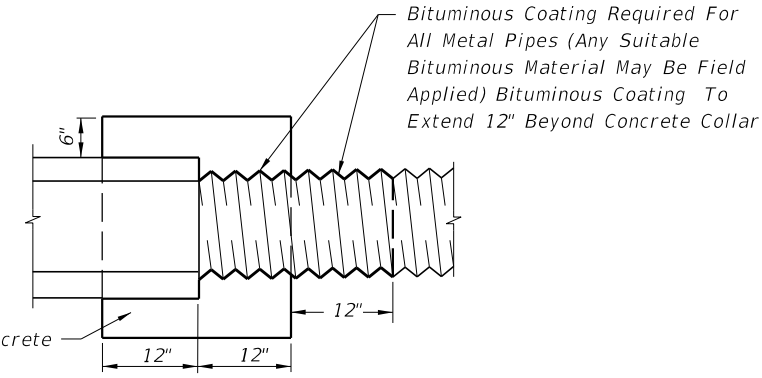

Note: Cost of concrete and bituminous coating to be included in contract unit price for either new pipe or Mitered End Section.

Alternate connection must be approved by the State Drainage Engineer.

Do not use a concrete jacket to join metal pipes of dissimilar materials.

DISSIMILAR TYPES

CONCRETE JACKET FOR CONNECTING DISSIMILAR TYPES OF PIPE AND CONCRETE PIPES WITH DISSIMILAR JOINTS

10/30/2018 8:46:49 AM

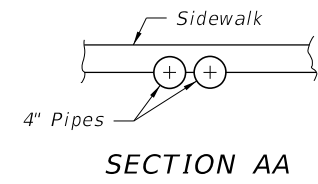
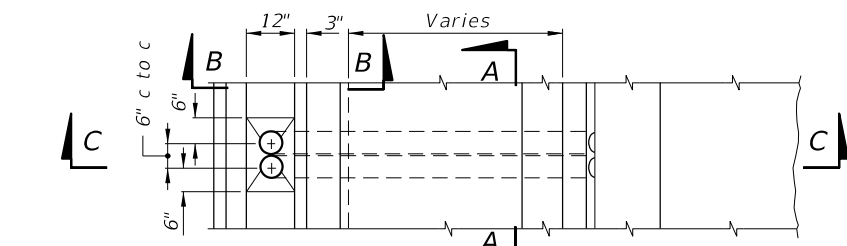

SECTION AA

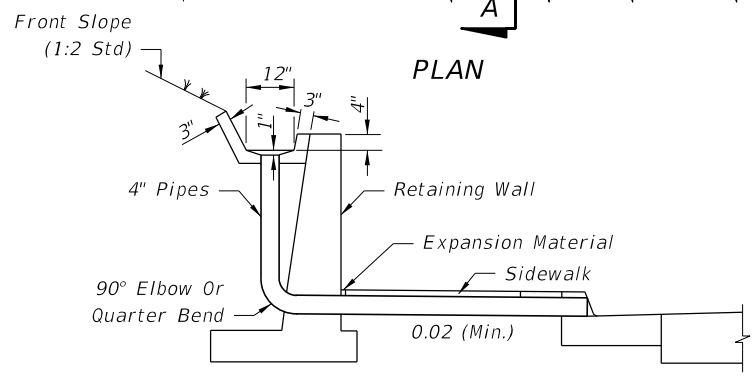

SECTION CC

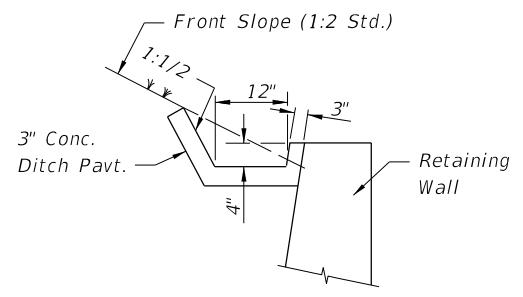

SECTION BB

Note: PVC pipe, Schedule 40, to be paid for under the contract unit price for Polyvinyl Chloride Pipe Culvert (4"), LF.

CONCRETE GUTTER AND DRAINS AT RETAINING WALLS

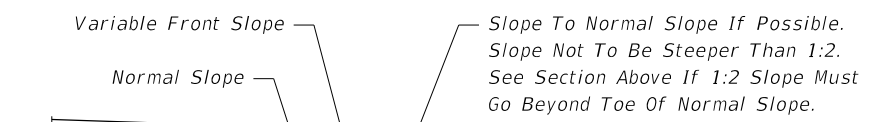
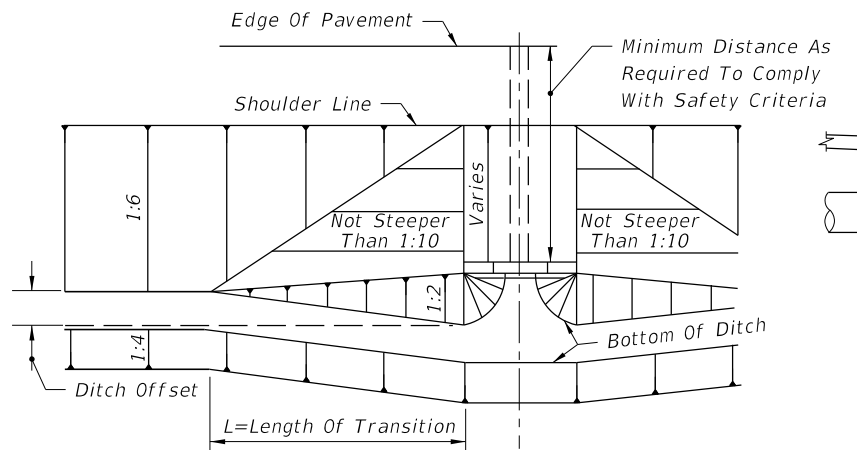

NOTE: Filling or excavation of variable slopes to be done during normal grading operations.

SECTION CC

- Use Larger Value Of Either:
1. $L=10 \times H$ (No Maximum)
 2. $L=10 \times \text{Ditch Offset}$ (Maximum $L=100'$)

METHOD FOR SETTING LIMITS OF VARIABLE FRONT SLOPES AT DRAINAGE STRUCTURES

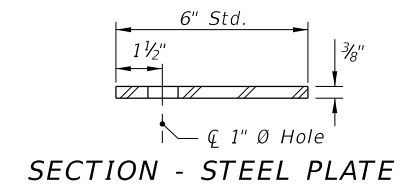

SECTION - STEEL PLATE

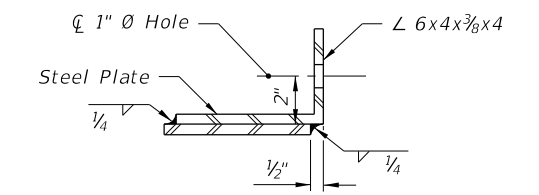

CLIP DETAIL

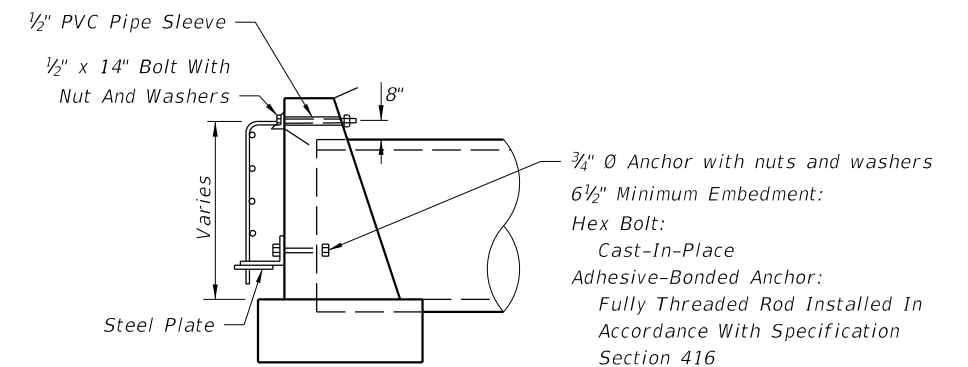

SIDE VIEW

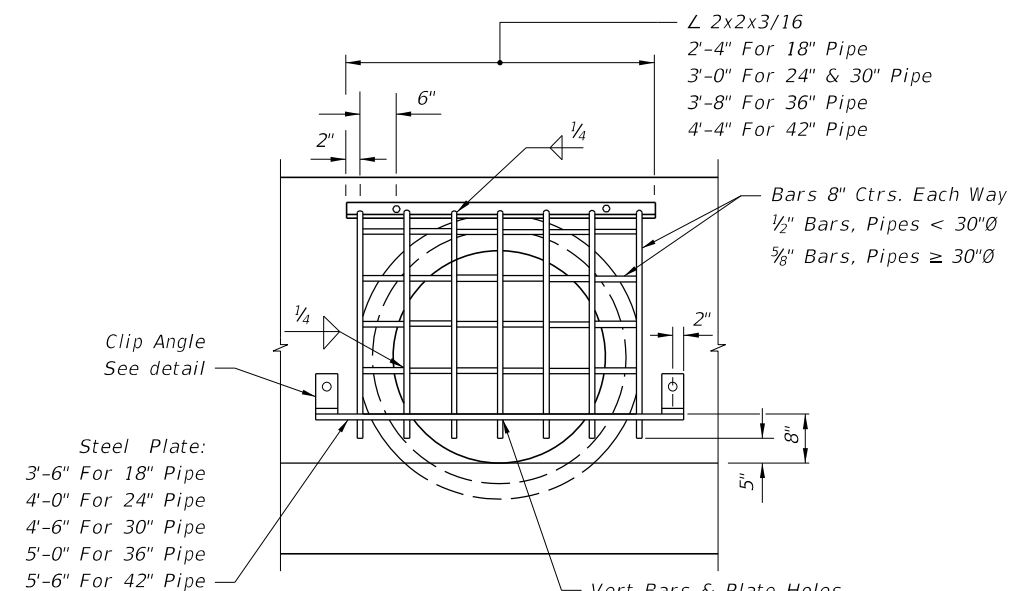

FRONT VIEW

Pipe Dia.	18"	24"	30"	36"	42"
Grate (Lbs.)	48	58	74	90	111

Note: Guards to be constructed only at locations specifically called for in plans.

GUARD AT PIPE ENDS

10/30/2018 8:46:55 AM

RAILROAD COMPANY	CLEARANCE BELOW BOTTOM OF RAIL (FEET) ⁽²⁾	STRENGTH
		ASTM (C76) CLASS
Alabama & Gulf Coast Railway (Rail America)	5.5	IV
AN Railway & Bay Line Railroad (Genesee & Wyoming)	5.5 / 4.5 ⁽¹⁾	V
CSX Transportation	5.5	V
First Coast Railroad (Genesee & Wyoming)	5.5 / 4.5 ⁽¹⁾	V
Florida Midland, Central, and Northern Railroads (Pinsly Railroad)	5.5	V
Florida East Coast (FEC) Railway Company	5.5	IV
Florida West Coast Railroad Company	5.5	V
Georgia & Florida Railway, Inc.	5.5	V
Norfolk Southern (NS) Railway Corporation	5.5 / 4.5 ⁽¹⁾	V
Port of Palm Beach District Railroad	5.5	IV
Seminole Gulf Railway (LP)	6.0	V
South Central Florida Express	6.0	V
Talleyrand Terminal Railroad (Genesee & Wyoming)	5.5 / 4.5 ⁽¹⁾	V
South Florida Regional Transportation Authority (Tri-County Commuter Rail)	5.5	V

(1) - Distance standard for yard and industrial tracks.

(2) - Clearance is for casing pipe. All subgrade carrier pipelines and wirelines will be installed within a casing pipe which will extend from Right-of-Way line to Right-of-Way line.

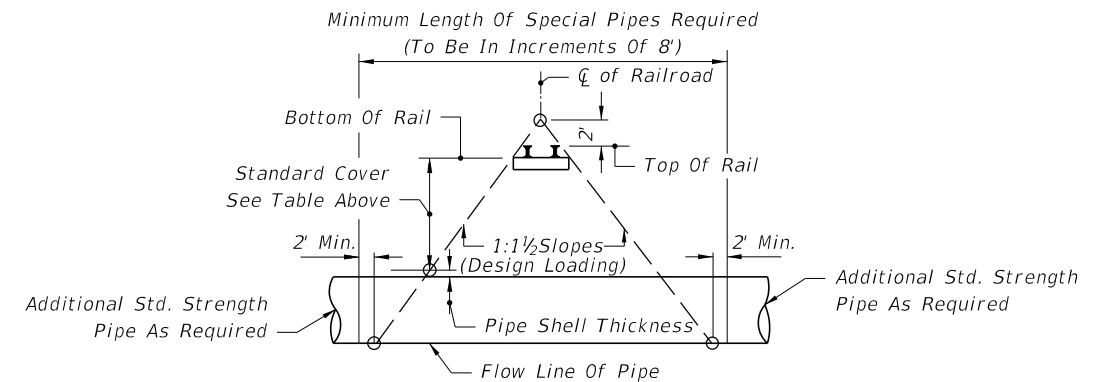

METHOD FOR DETERMINING THE LENGTH OF SPECIAL PIPE REQUIRED UNDER RAILROADS

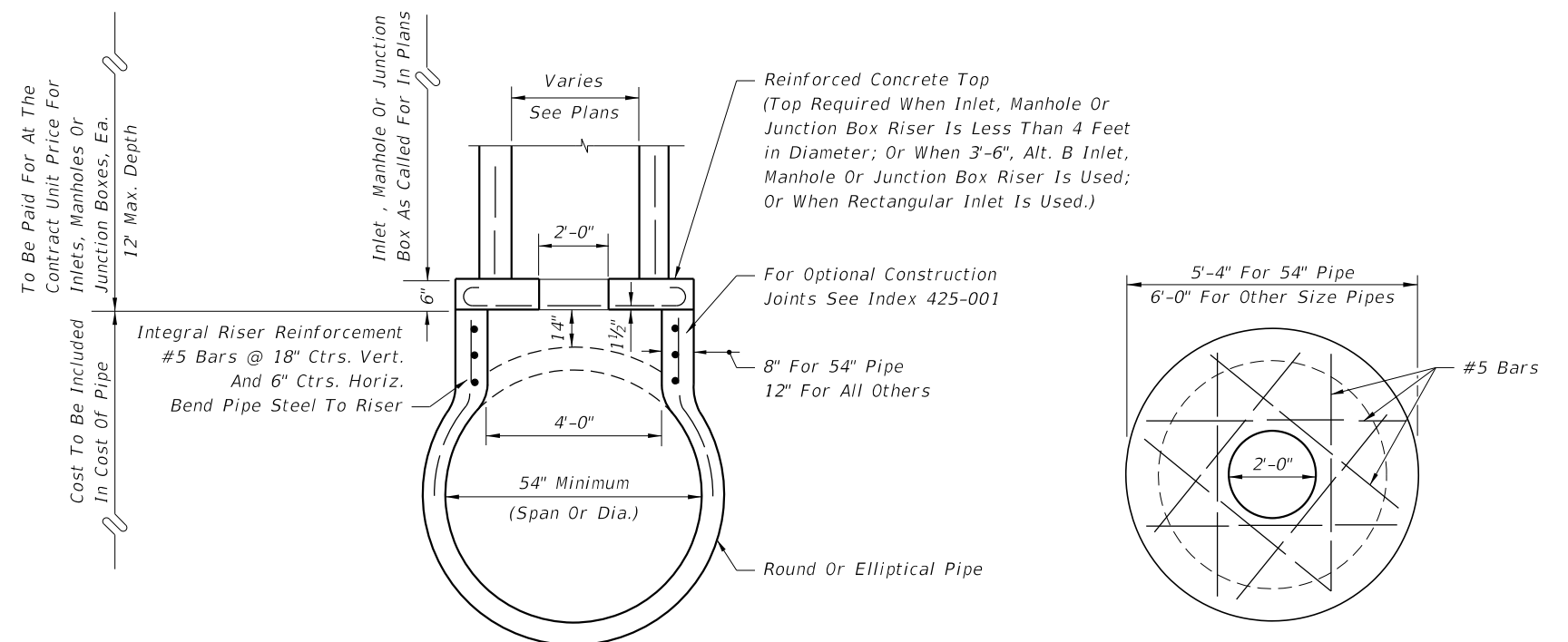

SECTION

PLAN OF TOP

INLETS, MANHOLES OR JUNCTION BOXES ON INTEGRAL PRECAST CONCRETE RISER FOR CONCRETE PIPE

10/30/2018 8:47:01 AM

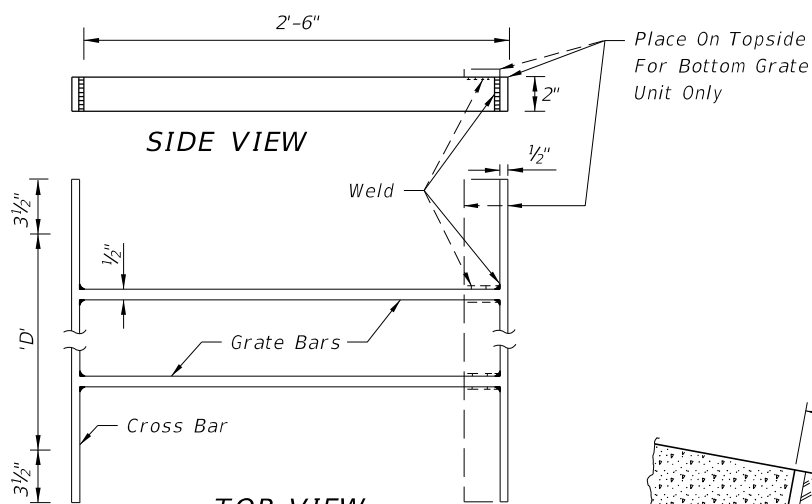

**TOP VIEW
GRATE TYPE NO. 1**

Pipe Size	Grate Bars Req'd.	Grate (lb)
15"	2	28.93

Bars to be evenly spaced across dimension 'D'.
All bars 1/2" x 2"

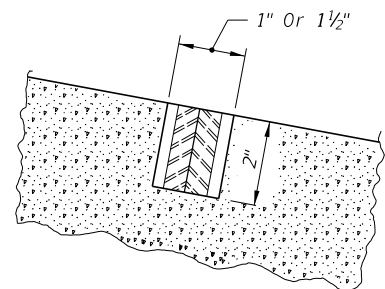

SECTION AA

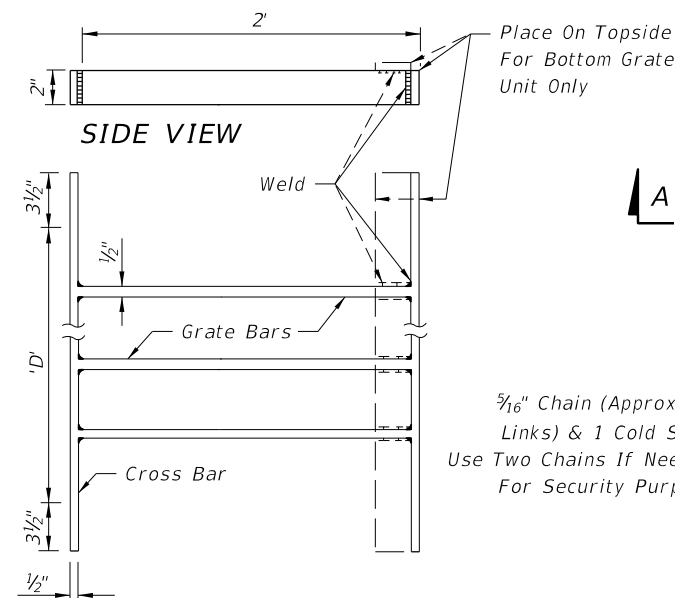

**TOP VIEW
GRATE TYPE NO. 2**

Pipe Size	Grate Bars Req'd.	Grate (lb)
18"	3	33.69
24"	4	43.63
30"	5	53.55

Bars to be evenly spaced across dimension 'D'.
All bars 1/2" x 2"

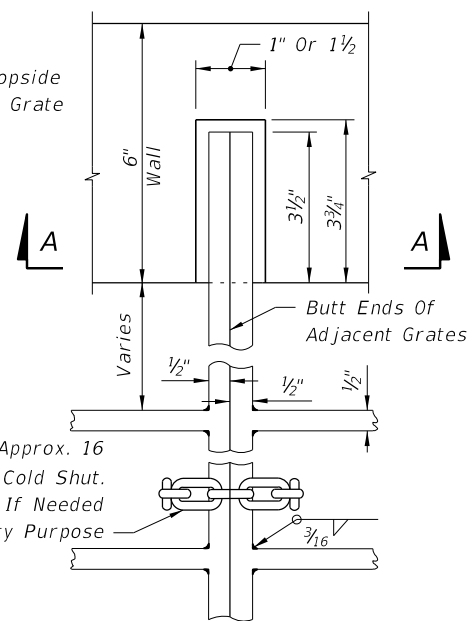

**TOP VIEW
GRATE, SEAT,
WELD & CHAIN DETAIL**

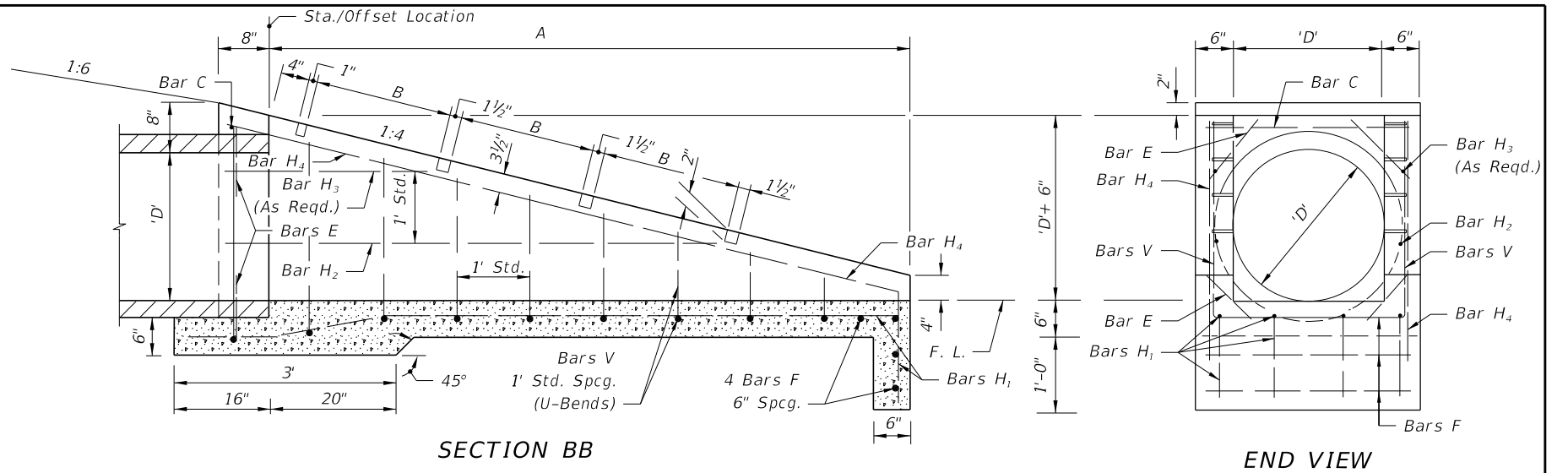

SECTION BB

END VIEW

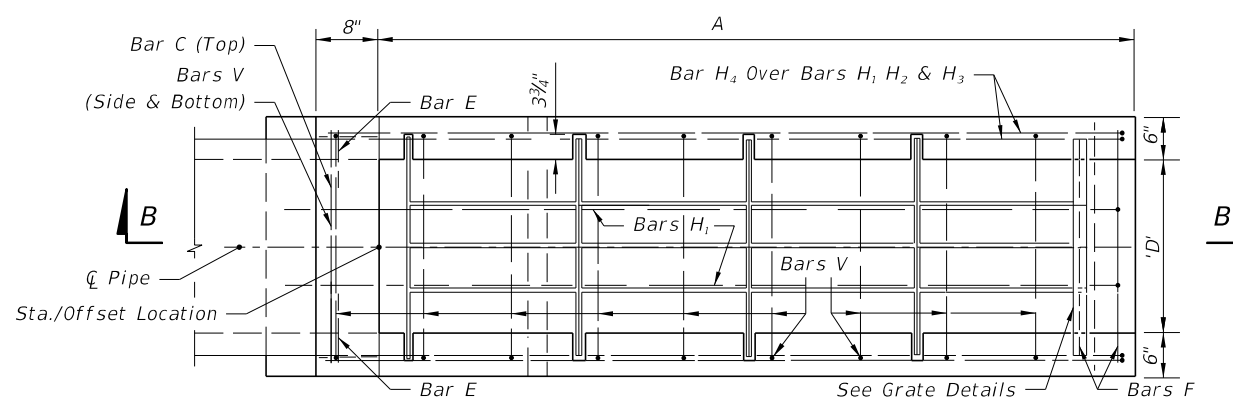

TOP VIEW

TABLE OF DIMENSIONS AND QUANTITIES											
Slope	Pipe Size D	A	B	Class I Conc. (CY)	Reinf. Steel (lb)	Number Of Grates Req'd.		Total Grate Wt. (lb)	Sodding (SY)	Slope Transition	
						Type No. 1	Type No. 2			Offset	L
1:4	15"	5.67'	2.38'	0.85	56	2	0	57.86	15	4.2'	42'
	18"	6.67'	1.875'	1.01	73	0	3	101.08	16	4.8'	48'
	24"	8.67'	1.875'	1.65	97	0	4	174.52	19	5.8'	58'
	30"	10.67'	1.875'	2.33	129	0	5	267.75	21	6.9'	69'

GENERAL NOTES

1. This endwall is to be used only in the clear zone for the drainage of medians and other areas having low design velocities and negligible debris.
2. Reinforcing steel: All bars are size #4. Spacings shown are center to center. Laps to be 1'-5" minimum. Cover is 2" except as noted. Square welded wire fabric (two cages max.) having an equivalent cross sectional area (0.20 sq. in.) may be substituted for bar reinforcement.
3. Grates shall be ASTM A242/A242M, A572/A572M or ASTM A588/A588M, Grade 50 steel. When "Alt. G" grates are specified in the plans, grates shall be galvanized in accordance with Section 975 and 425.3.2 of the Standard Specifications.
4. Endwall to be paid for under the contract unit price for U-Endwall, Each. Payment shall include cost of concrete, reinforcing steel, grate, and accessories. Quantities shown are for estimating purposes only.
5. Sod slopes 5' each side and above endwall. Sodding to be paid for under contract unit price for Performance Turf, SY.
6. Precasting of this endwall will be permitted. Precast units shall conform to the dimensions shown or in accordance with approved shop drawings. Request for shop drawing approval shall be directed to the State Drainage Engineer. Use Index 425-001 for opening and grouting details.
7. Concrete shall be Class I except ASTM C478 (4000 psi) concrete may be substituted for precast items manufactured in plants meeting the requirements of Section 449 of the Specifications.

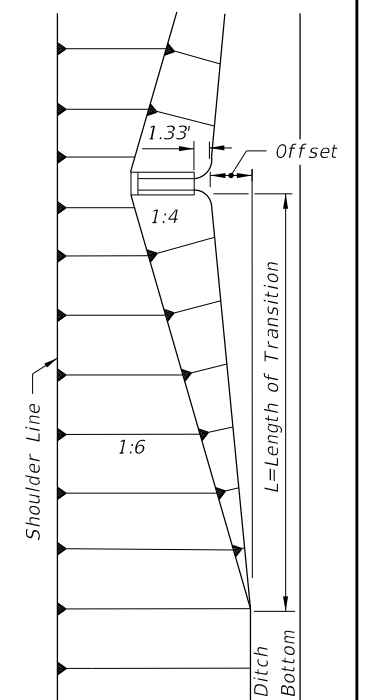

**FRONT SLOPE
TRANSITION AT ENDWALL**

10/30/2018 8:47:05 AM

LAST REVISION	DESCRIPTION:
11/01/17	



**FY 2019-20
STANDARD PLANS**

**U-TYPE CONCRETE ENDWALLS
WITH GRATES 15" TO 30" PIPE**

**INDEX
430-010**

**SHEET
1 of 1**

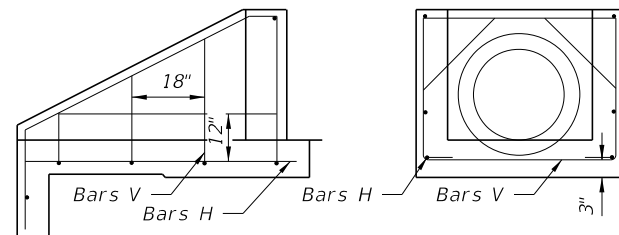
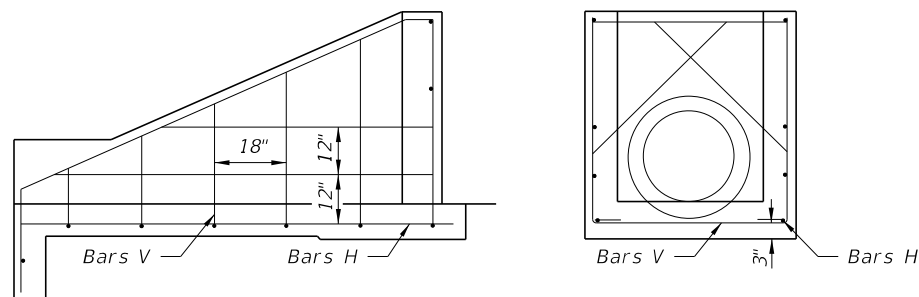
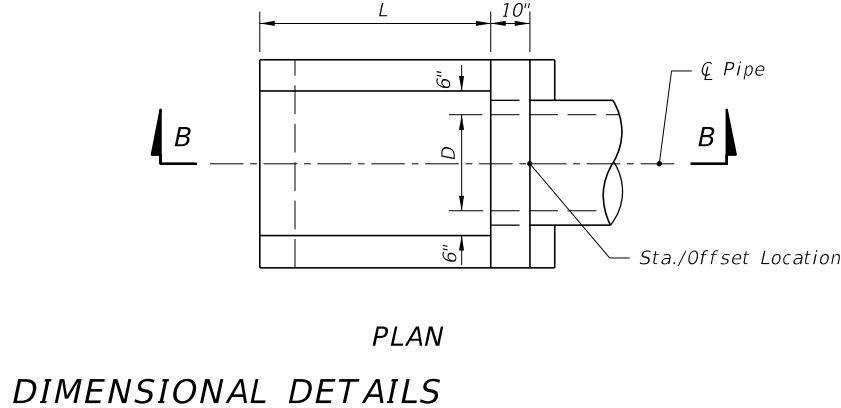
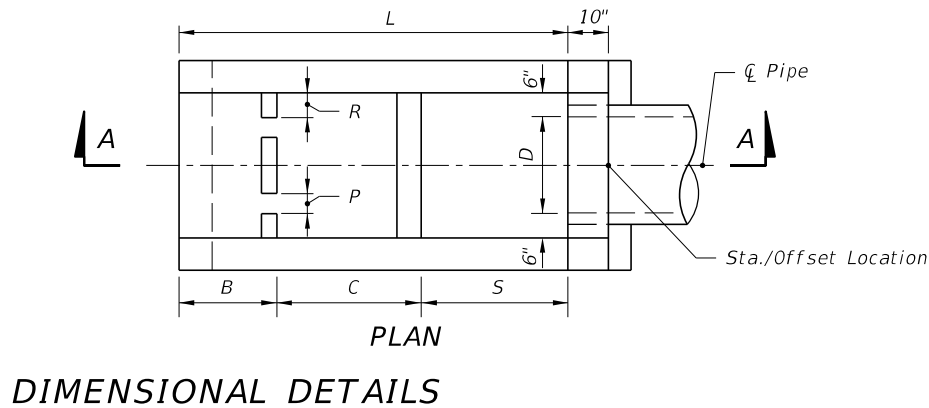
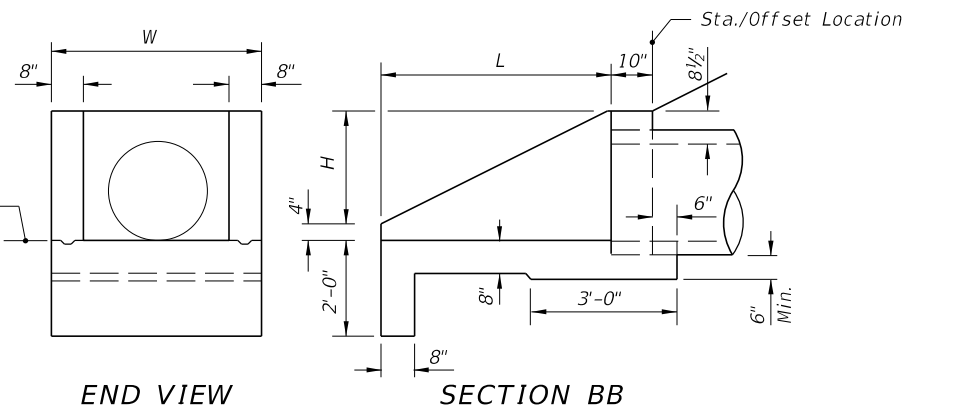
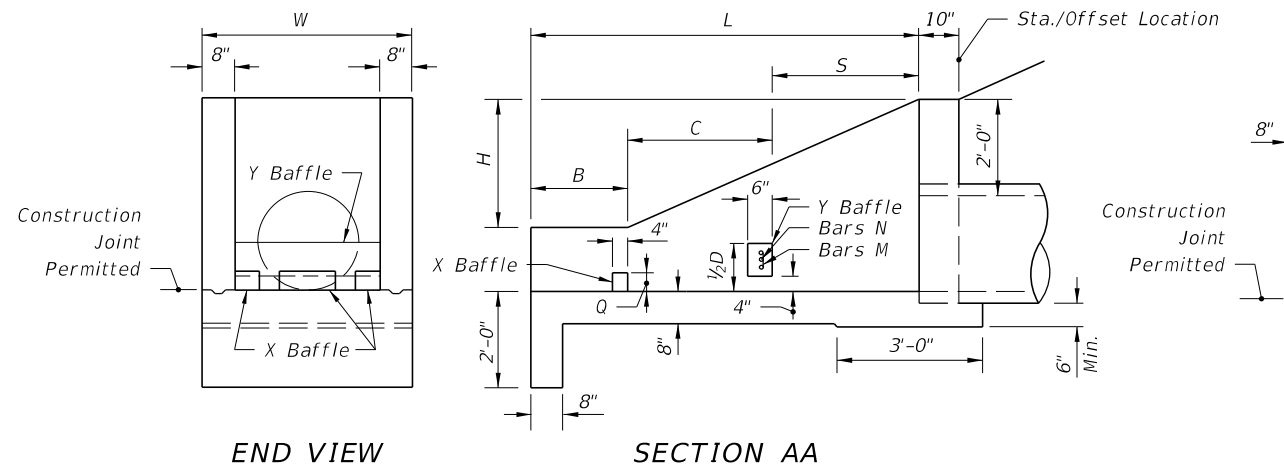

ALL PIPE SIZES
SIDE VIEW AND BACKWALL SECTION
REINFORCING DETAIL

ALL PIPE SIZES
SIDE VIEW AND BACKWALL SECTION
REINFORCING DETAIL

DIMENSIONS AND QUANTITIES FOR ONE U-ENDWALL														
Pipe Size		L	H	W	S	B	C	X Baffle			Y Baffle Reinf. Steel		Class I Conc. Cu. Yd.	Reinf. Steel Lbs.
D	Area Sq. Ft.							P	Q	R	Bar M	Bar N		
15"	1.23	5'-9"	2'-3 1/2"	3'-7"	2'-3"	1'-3"	2'-3"	4"	4"	4"	2 #4	1 #4	1.61	72
18"	1.77	6'-6"	2'-5"	3'-10"	2'-6"	1'-6"	2'-6"	4"	4"	5"	3 #4	2 #4	1.89	86
24"	3.14	8'-0"	2'-8"	4'-4"	3'-0"	2'-0"	3'-0"	5"	5"	6"	4 #4	3 #4	2.52	108
30"	4.91	9'-6"	2'-11"	4'-10"	3'-6"	2'-6"	3'-6"	5"	5"	7"	4 #4	4 #4	3.34	131

DIMENSIONS AND QUANTITIES FOR ONE U-ENDWALL						
Pipe Size		L	H	W	Class I Conc. Cu. Yd.	Reinf. Steel Lbs.
D	Area Sq. Ft.					
15"	1.23	3'-3"	1'-7 1/2"	3'-7"	0.89	39
18"	1.77	3'-9"	1'-10 1/2"	3'-10"	1.05	43
24"	3.14	4'-9"	2'-4 1/2"	4'-4"	1.40	55
30"	4.91	5'-9"	2'-10 1/2"	4'-10"	1.88	64

WITH BAFFLES

WITHOUT BAFFLES

ENDWALLS FOR 1:2 SLOPES

GENERAL NOTES

- Baffles to be constructed only when called for in plans.
- When steel grating is required on endwall see Sheet 3 of 3 for details.
- All reinforcing No. 4 bars with 2" clearance except as noted.
- All angles, channels and bars shall be ASTM A242/A242M, A572/A572M or A588/A588M Grade 50 steel. When designated Alternate G in the plans galvanize in accordance with Section 975 and 425-3.2 of the Standard Specifications.
- Channel section C 3x6 may be substituted for C 4x5.4 channel.
- Precasting of this endwall will be permitted. Precast units shall conform to the dimensions shown or in accordance with approved shop drawings. Request for shop drawing approval shall be directed to the State Drainage Engineer. Use Index 425-001 for opening and grouting details.
- Concrete shall be Class I, except ASTM C478 (4000 psi) concrete may be substituted for precast items manufactured in plants meeting the requirements of Section 449 of the Specifications.
- Sodding shall be in accordance with Index 524-001, and paid for under the contract unit price for Performance Turf, SY.
- Endwall to be paid for under the contract unit price for U-Endwall, Each. Payment shall include cost of concrete, reinforcing steel, and when called for in the plans, steel grating, baffles and accessories. Quantities shown are for estimating purposes only.

10/30/2018 8:47:08 AM

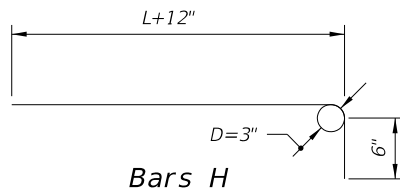

Bars H

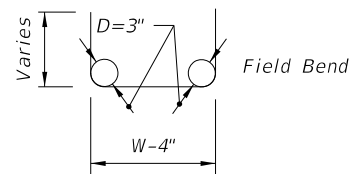

Bars V
BENDING DIAGRAM

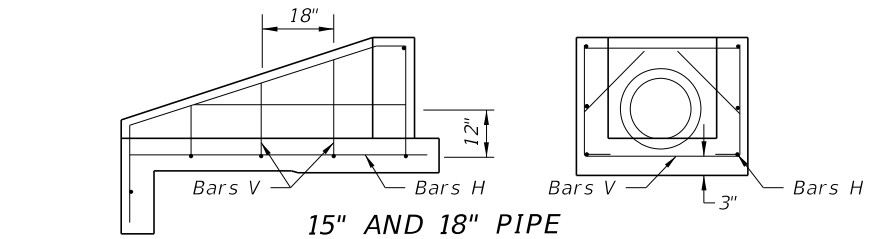

15" AND 18" PIPE

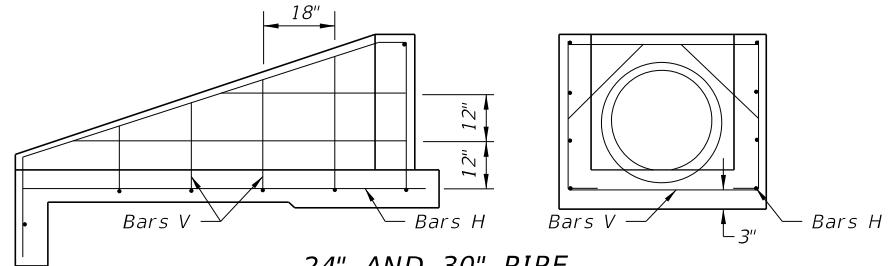

24" AND 30" PIPE
1:3 SLOPES

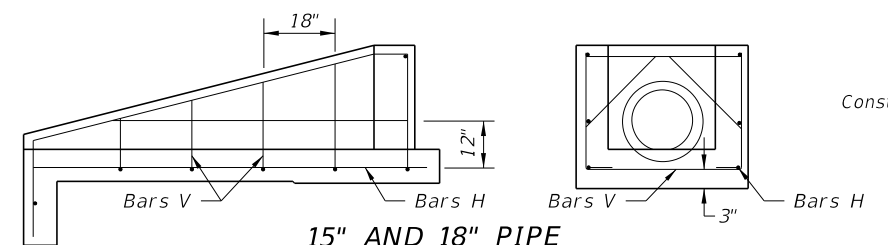

15" AND 18" PIPE

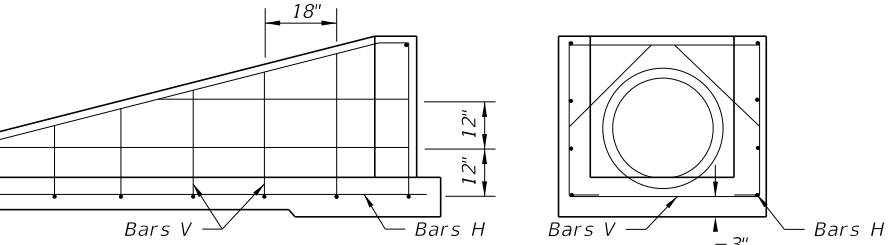

24" AND 30" PIPE
1:4 SLOPES

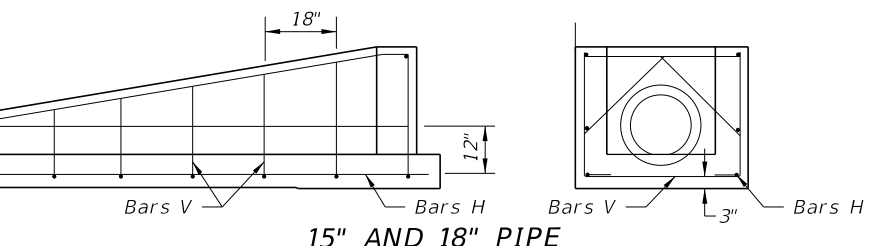

15" AND 18" PIPE

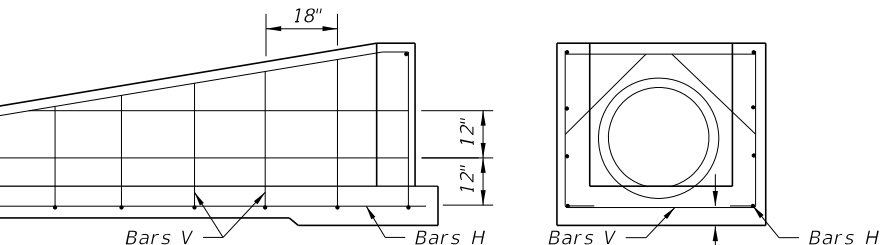

24" AND 30" PIPE
1:6 SLOPES

SIDE VIEWS AND BACKWALL SECTIONS
REINFORCING DETAILS

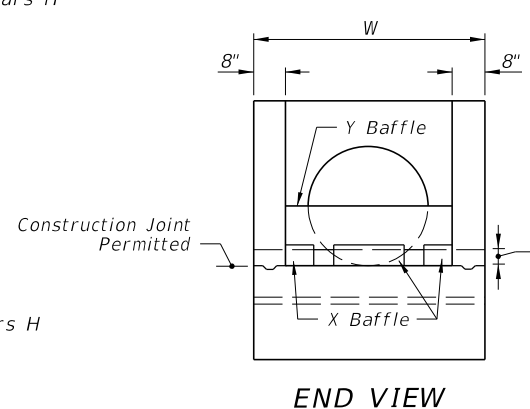

END VIEW

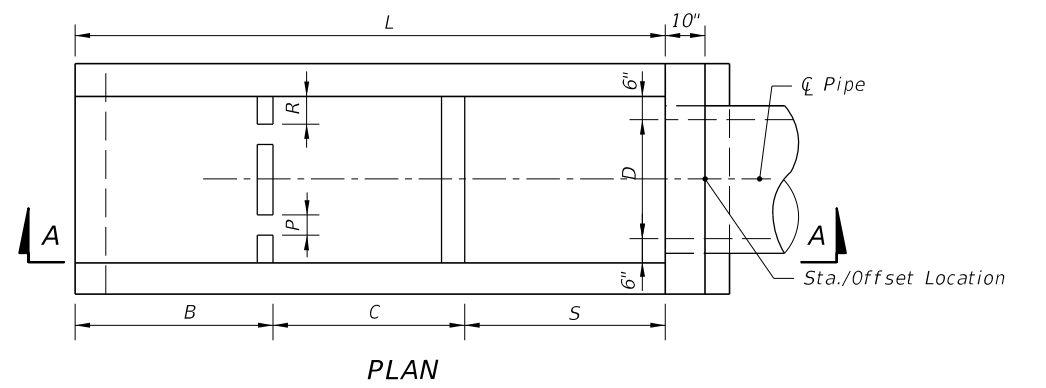

PLAN

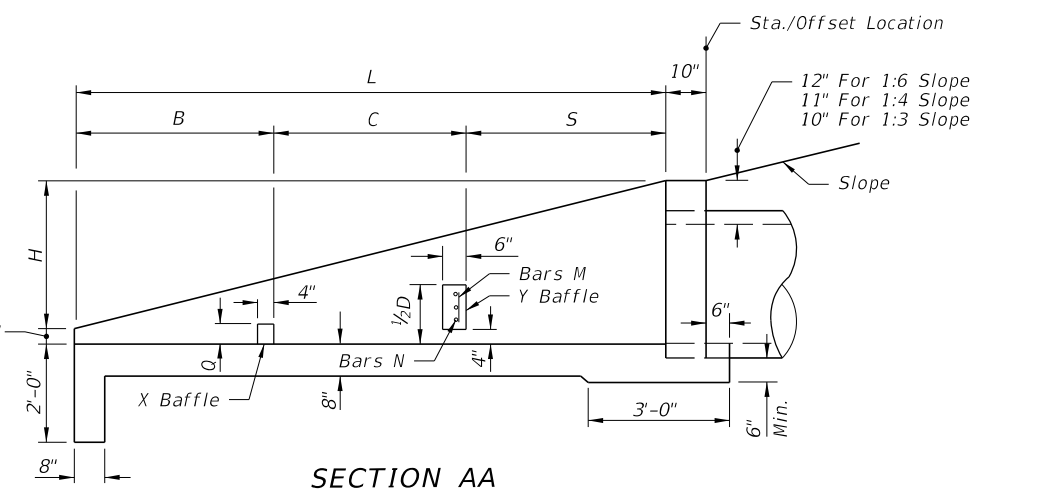

SECTION AA

DIMENSIONAL DETAILS

DIMENSIONS AND QUANTITIES FOR BAFFLES							
Pipe Size D	X Baffle			Ybaffle Reinf. Steel		Class I Concrete Cu. Yd.	Reinf. Steel Lbs
	P Width	Q Height	R Length	Bar M	Bar N		
15"	4"	4"	4"	2- #4	1- #4	0.10	4
18"	4"	4"	5"	3- #4	2- #4		8
24"	5"	5"	6"	4- #4	3- #4		12
30"	5"	5"	7"	4- #4	4- #4		16

DIMENSIONS AND QUANTITIES FOR ONE U-ENDWALL												
Rate Of Slope	Pipe Size		L	H	W	Baffle Locations (When Required)			Class I Concrete Cu. Yd.	Reinf. Steel Lbs.		
	D	Area (Sq. Ft.)				S	B	C				
1:3	15"	1.23	5'-3"	1'-9"	3'-7"	1'-9"	1'-9"	1'-9"	1.19	51		
	18"	1.77	6'-0"	2'-0"	3'-10"	2'-0"	2'-0"	2'-0"	1.42	56		
	24"	3.14	7'-6"	2'-6"	4'-4"	2'-6"	2'-6"	2'-6"	1.94	77		
	30"	4.91	9'-0"	3'-0"	4'-10"	3'-0"	3'-0"	3'-0"	2.54	96		
1:4	15"	1.23	7'-4"	1'-10"	3'-7"	2'-6"	2'-6"	2'-4"	1.54	64		
	18"	1.77	8'-4"	2'-1"	3'-10"	2'-10"	2'-10"	2'-8"	1.84	71		
	24"	3.14	10'-4"	2'-7"	4'-4"	3'-6"	3'-6"	3'-4"	2.53	92		
1:6	15"	1.23	12'-4"	3'-1"	4'-10"	4'-2"	4'-2"	4'-0"	3.34	124		
	15"	1.23	11'-6"	1'-11"	3'-7"	3'-10"	3'-10"	3'-10"	2.19	89		
	18"	1.77	13'-0"	2'-2"	3'-10"	4'-4"	4'-4"	4'-4"	2.63	103		
	24"	3.14	16'-0"	2'-8"	4'-4"	5'-4"	5'-4"	5'-4"	3.59	143		
			30"	4.91	19'-0"	3'-2"	4'-10"	6'-4"	6'-4"	6'-4"	4.81	180

ENDWALLS WITH AND WITHOUT BAFFLES FOR 1:3, 1:4 AND 1:6 SLOPES

10/30/2018 8:47:11 AM

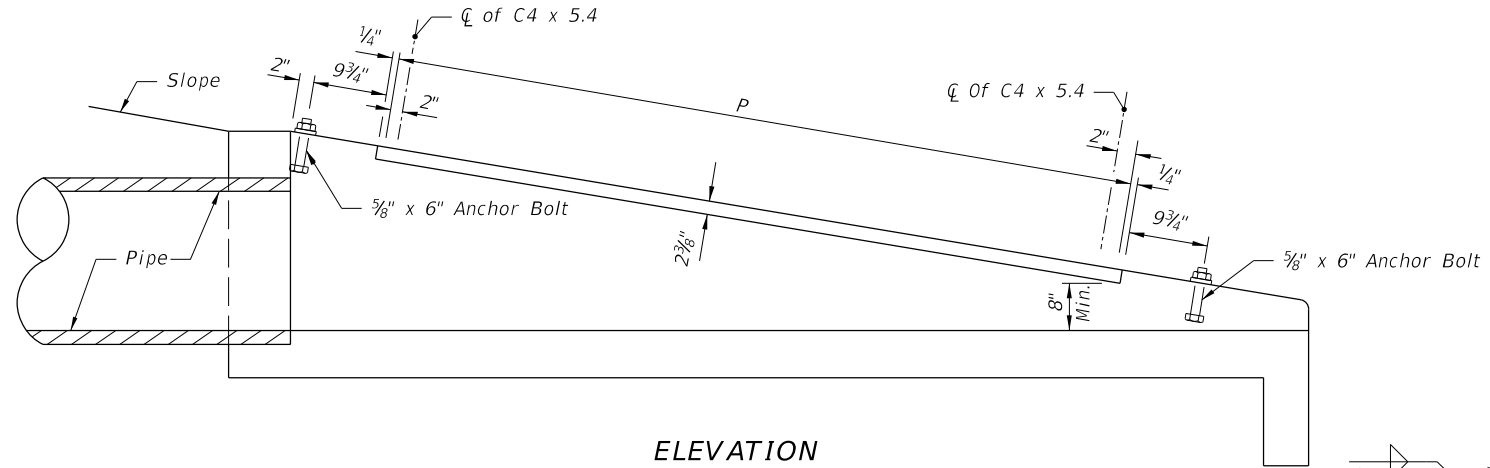

ELEVATION

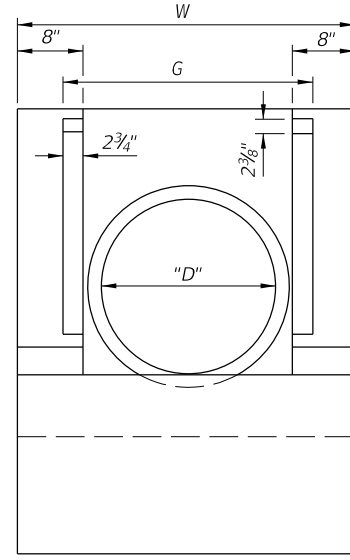

END VIEW

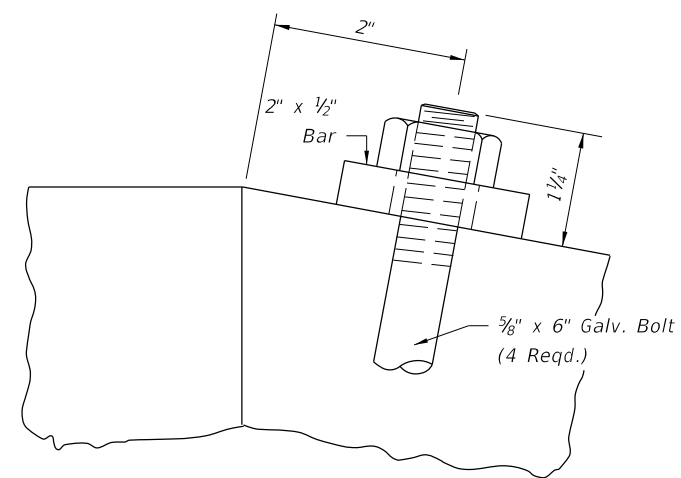

ANCHOR BOLT DETAIL

MOUNTING FOR STEEL GRATE

STEEL GRATING USE CRITERIA

1. Provide positive debris control at all upgradient openings. Do not install grates unless one or more of the following conditions exist:
 - A. Pipe culvert endwalls are located within the designated clear zone.
 - B. Drainage area to culvert consists of median or infield areas or areas where debris and/or drift is negligible.
 - C. Runoff to culvert is by sheet flow or in such ill defined channels that debris transport is not considered a major problem.
 - D. Runoff to culvert is minor except on an infrequent basis (10 to 15 year frequency); for example a drainage basin in flat sandy terrain with normally low ground water table.
 - E. Areas where culvert blockage with resultant backwater would not seriously affect roadway embankment, traffic operation or upland property.
2. Steel grating to be used only where called for in plans.

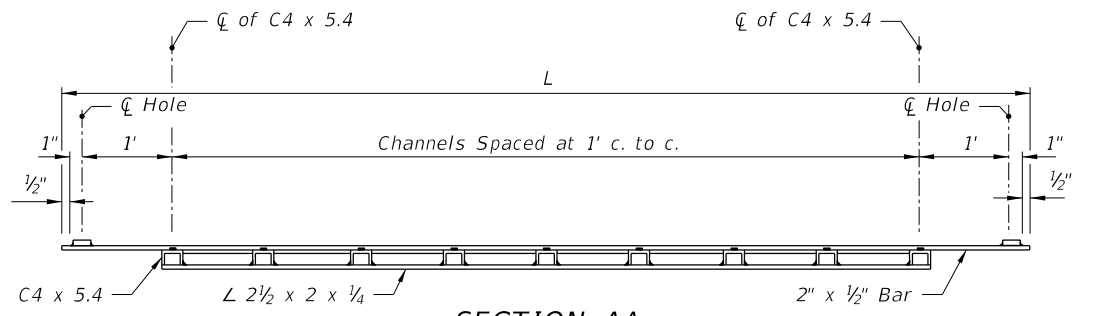

SECTION AA

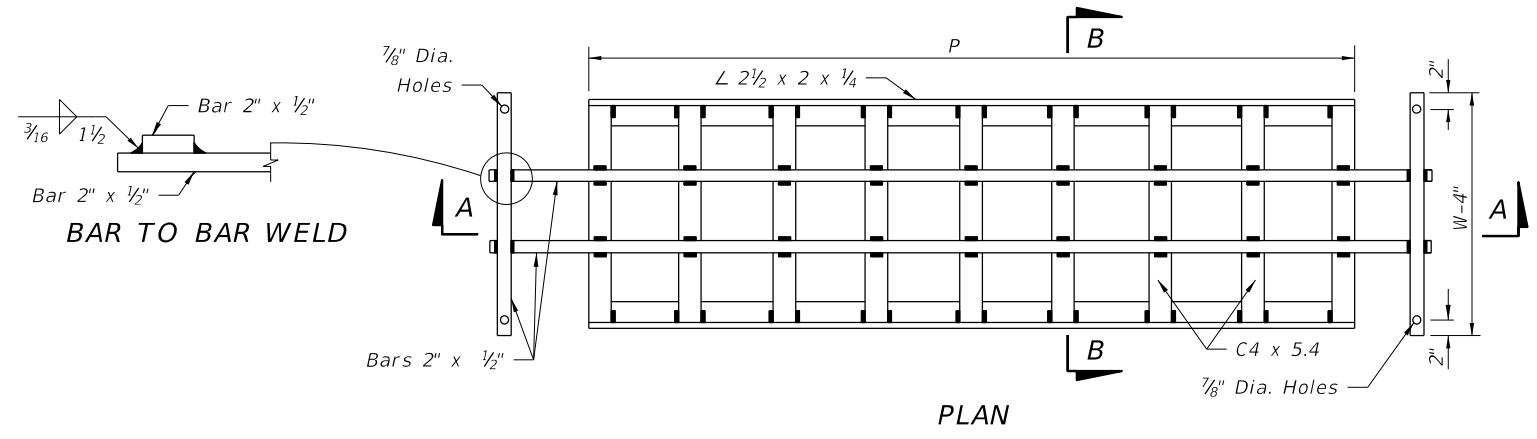

PLAN

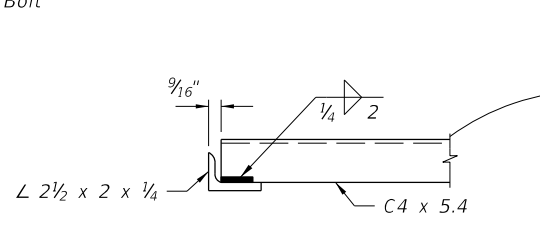

CHANNEL TO ANGLE WELD

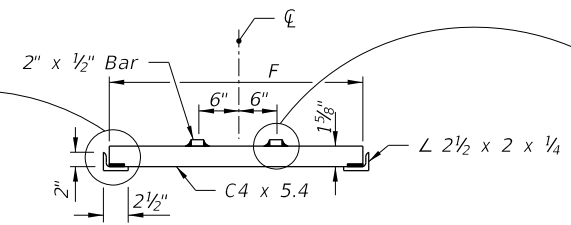

SECTION BB

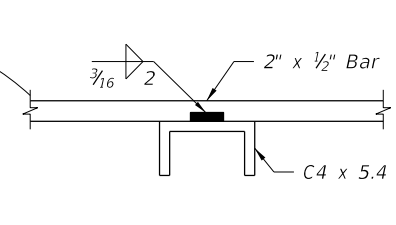

BAR TO CHANNEL WELD

STEEL GRATE

TABLE OF DIMENSIONS AND QUANTITIES FOR ONE GRATE											
Rate Of Slope	Size Pipe D	G	2 Each Bars @ 3.4 lb/ft			(X) Channels @ 5.4 lb/ft			2 Angles @ 3.62 lb/ft		Total Weight (lb)
			L	W-4"	lb	(X)	F	lb	P	lb	
1:6	15"	2' - 8 1/2"	9'-3"	3'-3"	85	8	2' - 6 7/8"	111	7'-4"	53	249
	18"	2' - 11 1/2"	10'-3"	3'-6"	94	9	2' - 9 7/8"	137	8'-4"	62	292
	24"	3' - 5 1/2"	13'-3"	4'-0"	117	12	3' - 3 7/8"	215	11'-4"	82	414
	30"	3' - 11 1/2"	16'-3"	4'-6"	141	15	3' - 9 7/8"	310	14'-4"	104	555
1:4	15"	2' - 8 1/2"	6'-3"	3'-3"	65	5	2' - 6 7/8"	70	4'-4"	32	167
	18"	2' - 11 1/2"	7'-3"	3'-6"	73	6	2' - 9 7/8"	92	5'-4"	39	204
	24"	3' - 5 1/2"	9'-3"	4'-0"	90	8	3' - 3 7/8"	144	7'-4"	53	287
	30"	3' - 11 1/2"	11'-3"	4'-6"	107	10	3' - 9 7/8"	206	9'-4"	68	381
1:3	15"	2' - 8 1/2"	4'-3"	3'-3"	51	3	2' - 6 7/8"	42	2'-4"	17	110
	18"	2' - 11 1/2"	5'-3"	3'-6"	60	4	2' - 9 7/8"	61	3'-4"	24	145
	24"	3' - 5 1/2"	6'-3"	4'-0"	70	5	3' - 3 7/8"	90	4'-4"	31	191
	30"	3' - 11 1/2"	8'-3"	4'-6"	87	7	3' - 9 7/8"	145	6'-4"	46	278

10/30/2018 8:47:17 AM

LAST REVISION	DESCRIPTION:
11/01/17	

**FY 2019-20
STANDARD PLANS**

**U-TYPE CONCRETE ENDWALLS BAFFLES
& GRATE OPTIONAL 15" TO 30" PIPE**

INDEX	SHEET
430-011	3 of 3

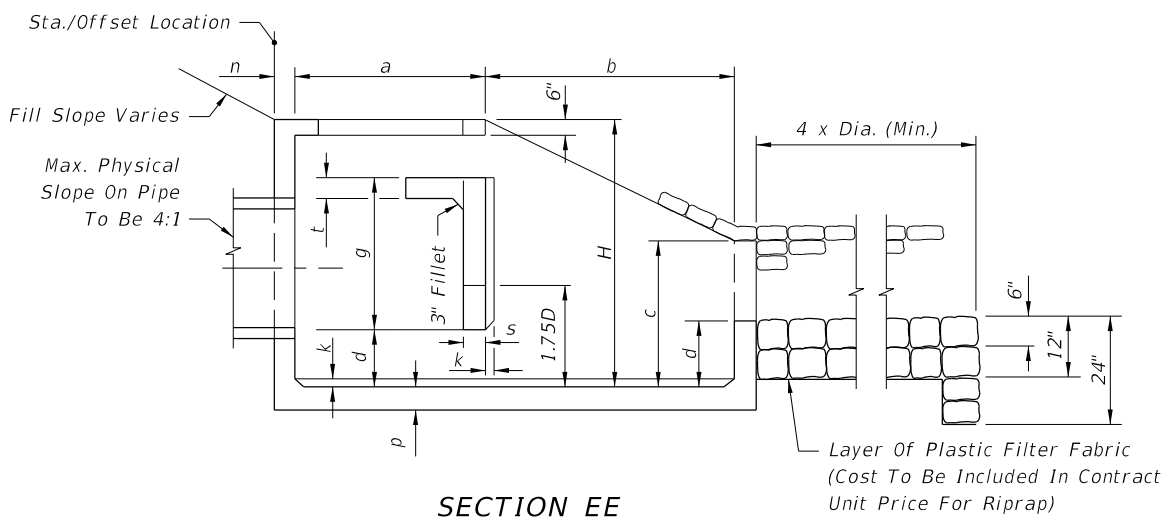
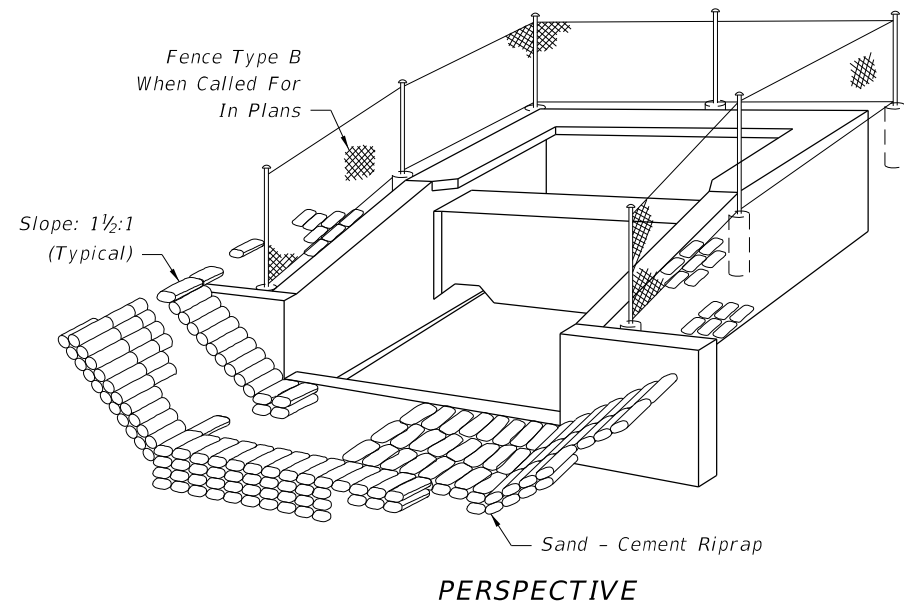
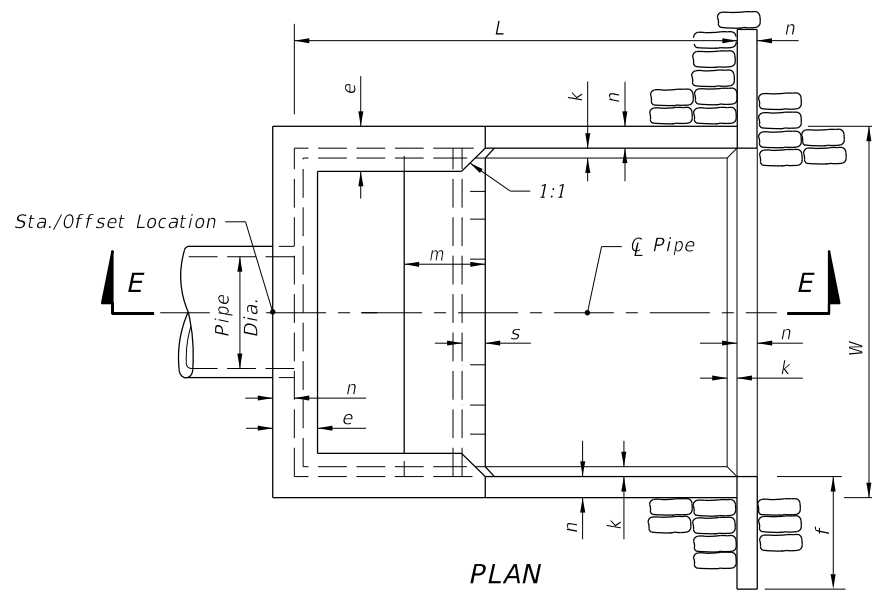

GENERAL NOTES

1. U-type concrete endwall energy dissipators are intended for use outside the clear zone.
2. Chamfer all exposed edges $\frac{3}{4}$ ".
3. Concrete shall be Class I, except ASTM C478 (4000 psi) concrete may be substituted for precast items manufactured in plants meeting the requirements of Section 449 of the Specifications.
4. Reinforcing steel shall have 2" min. cover.
5. Endwall to be paid for under the contract unit price for Class I Concrete (Endwalls), CY and Reinforcing Steel (Roadway), LB. Riprap to be paid for under the contract unit price for Riprap (Sand-Cement) (Roadway), CY. Cost of plastic filter fabric to be included in the contract unit price for riprap.
6. Fencing, when called for in the plans, to be paid for under the contract unit price for Fencing, Type B, LF. See Index 550-002 for details of Type B fencing.

Pipe Size		Q (Max) (cfs)	Dimensions															Concrete Class I (CY)	Reinf. Steel (lb)	Sand-Cement Riprap (Nom.) (CY)	
Dia. (in)	Area (SF)		Feet - Inches										Inches								
			W	H	L	a	b	c	d	e	f	g	m	n	p	s	t				k
30	4.91	59	9-0	6-3	10-8	4-7	6-1	3-4	1-4	1-2	2-6	3-0	1-11	6	6½	7	7	3	6.72	736	10.6
36	7.07	85	10-5	7-3	12-4	5-3	7-1	3-10	1-7	1-3	3-0	3-6	2-3	7	7½	8	8	3	10.34	1,072	13.6
42	9.62	115	11-10	8-0	14-0	6-0	8-0	4-5	1-9	1-6	3-0	3-11	2-6	8	8½	9	8	4	14.82	1,429	17.5
48	12.57	151	13-3	9-0	15-8	6-9	8-11	4-11	2-0	1-7	3-0	4-5	2-10	9	9½	10	8	4	20.36	2,000	22.1
54	15.90	191	14-8	9-9	17-4	7-4	10-0	5-5	2-2	1-10	3-0	4-11	3-0	10	10½	10	8	4	27.19	2,659	27.2
60	13.63	236	16-1	10-9	19-0	8-0	11-0	5-11	2-5	1-11	3-0	5-4	3-4	11	11½	11	8	6	34.49	3,552	32.5
66	23.76	285	17-3	11-6	20-6	8-8	11-10	6-5	2-7	2-1	3-0	5-9	3-7	12	12½	12	8	6	42.82	4,472	38.3
72	28.27	339	18-6	12-3	22-0	9-3	12-9	6-11	2-9	2-3	3-0	6-2	3-9	12	12½	12	8	6	50.68	5,426	44.5

10/30/2018 8:47:20 AM

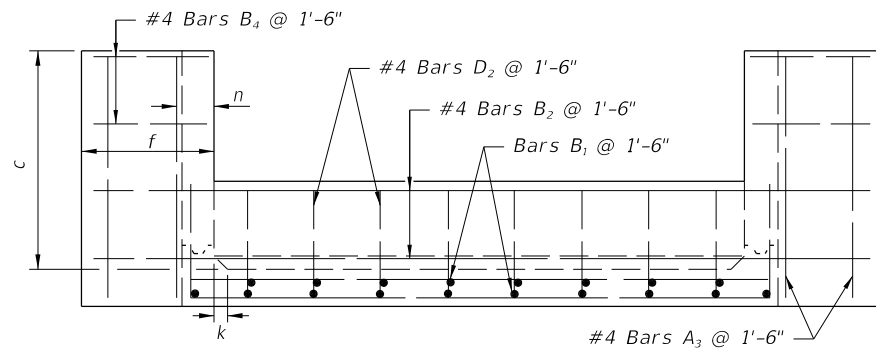
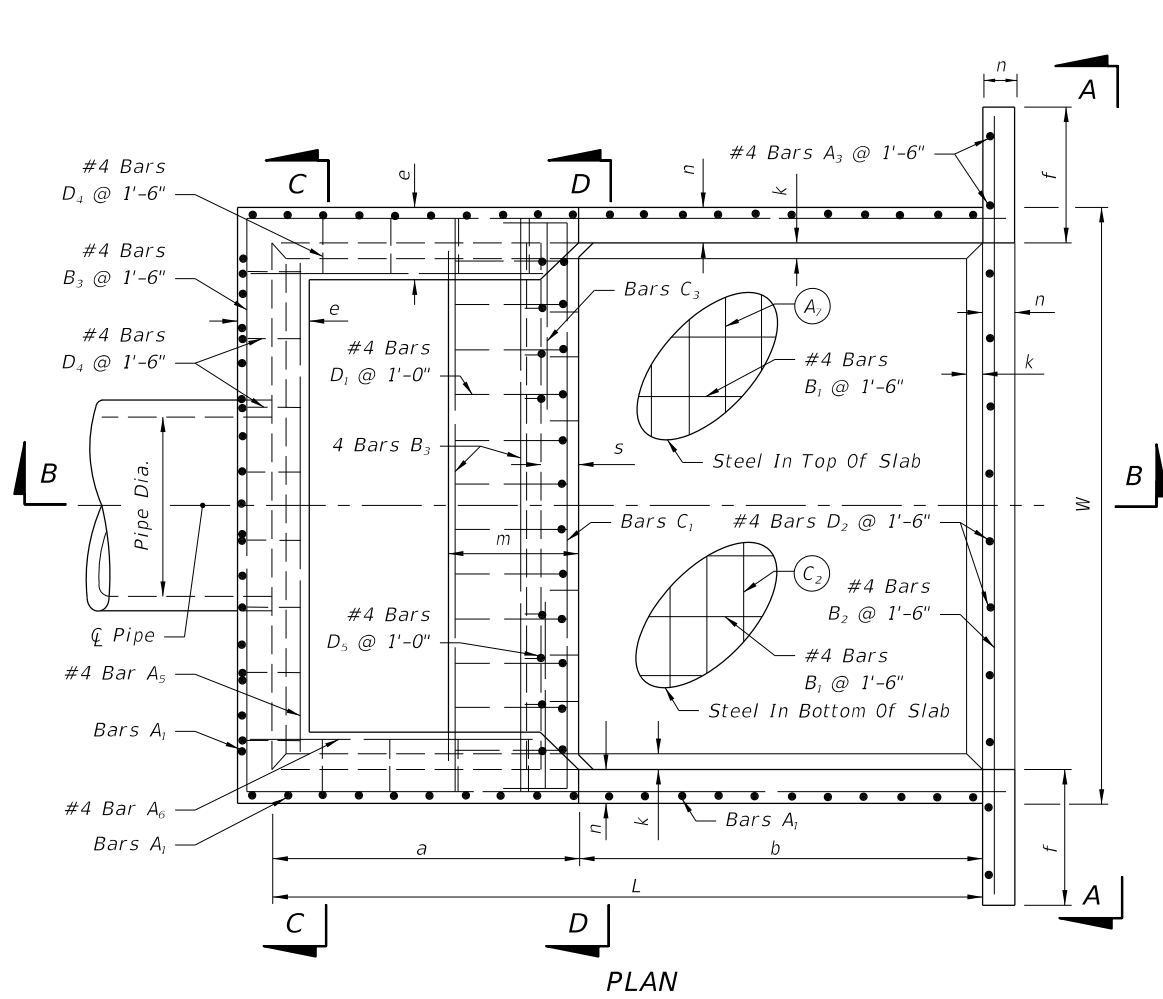

SECTION AA

Note: Bars C₄ & C₅ (N.S. & F.S.) equivalent in size to C₃ (cut and bend as required)

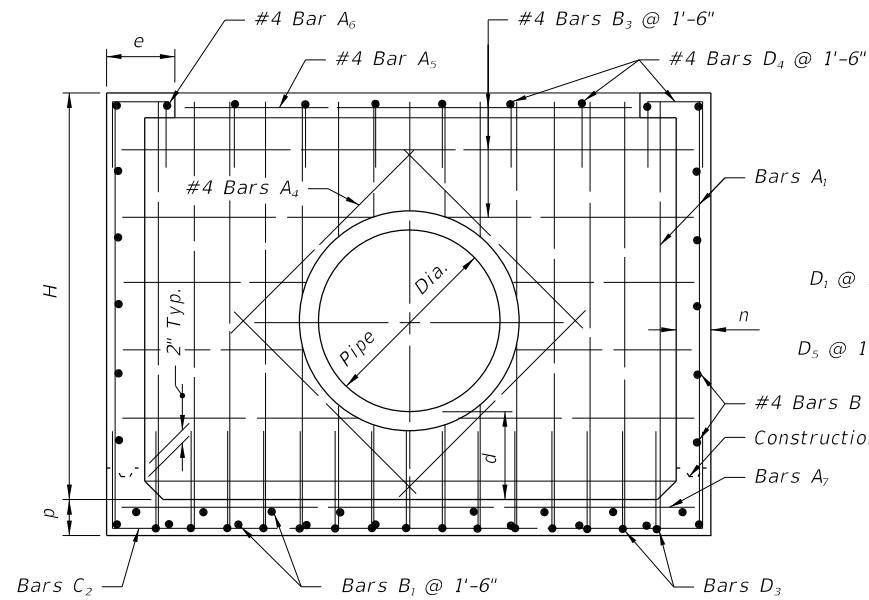

SECTION CC

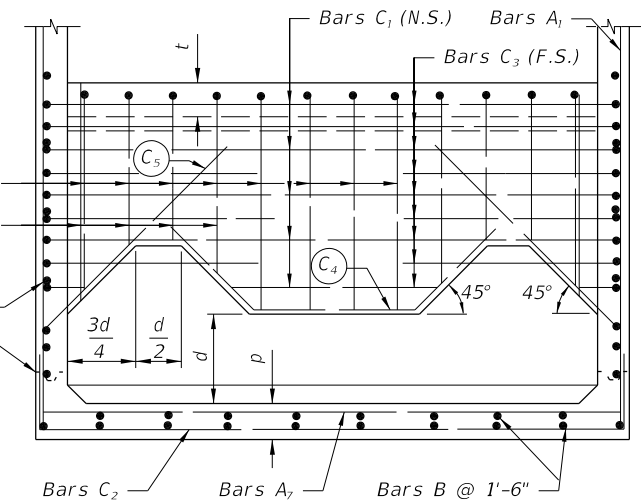

SECTION DD

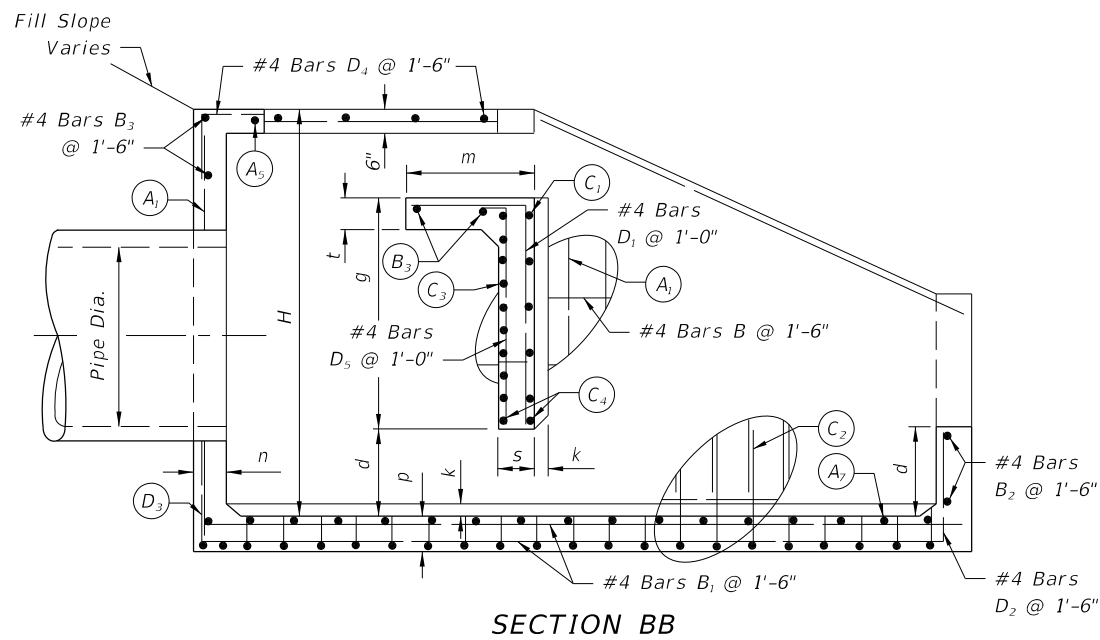

SECTION BB

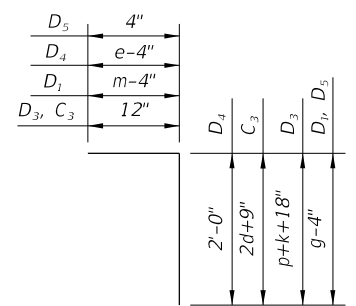

Bars: C₃, D₁, D₃, D₄, D₅

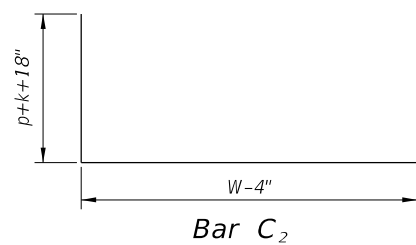

Bar C₂

Note: All bar dimensions are out to out.

BENDING DIAGM

Pipe Size	A ₁		A ₇		C ₁		C ₂		C ₃		D ₃	
	Size (No.)	Spacing (Ft.-In.)	Size (No.)	Spacing (Ft.-In.)	Size (No.)	Spacing (Ft.-In.)	Size (No.)	Spacing (Ft.-In.)	Size (No.)	Spacing (Ft.-In.)	Size (No.)	Spacing (Ft.-In.)
30"	4	0-9½	4	1-6	5	0-11	4	0-9½	5	0-5½	4	0-9½
36"	5	1-0	4	1-6	5	0-10	5	1-0	5	0-5	5	1-0
42"	5	0-11	4	1-6	6	1-1	5	0-11	6	0-6½	5	0-11
48"	5	0-9½	4	1-0	6	1-0	5	0-9½	6	0-6	5	0-9½
54"	5	0-8½	4	0-10	7	1-1	5	0-8½	7	0-6½	5	0-8½
60"	6	0-10	5	1-1	7	1-0	6	0-10	7	0-6	6	0-10
66"	6	0-8½	5	0-11½	7	0-11	6	0-8½	7	0-5½	6	0-8½
72"	6	0-7½	5	0-10	7	0-10	6	0-7½	7	0-5	6	0-7½

Note: Bars A₂, A₃, A₄, A₅, A₆, B₁, B₂, B₃, B₄, B are straight bars.

10/30/2018 8:47:23 AM

LAST REVISION	DESCRIPTION:
11/01/17	

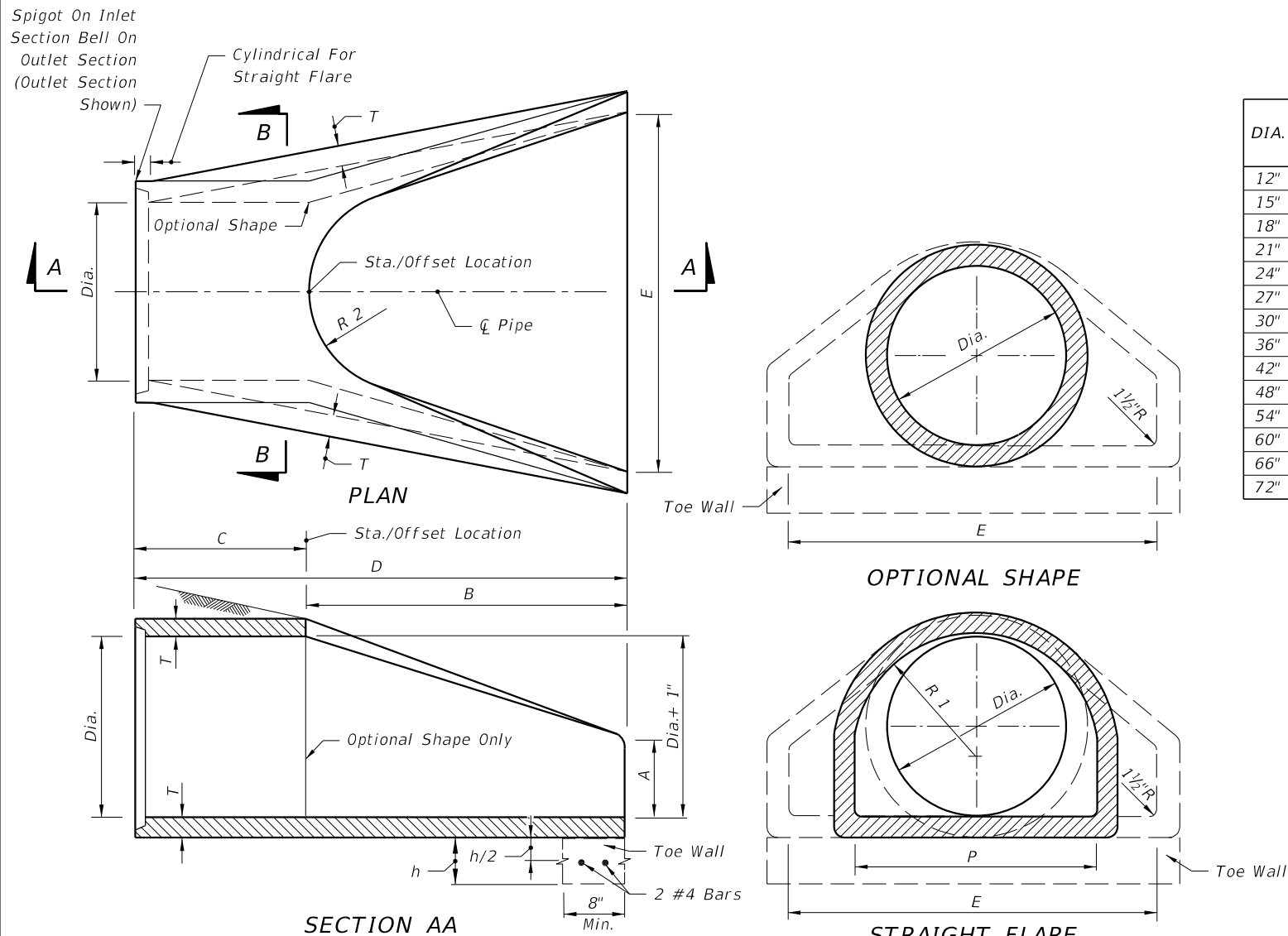

DIA.	T	REINF. (in'/ft)	BELL Or Spigot	A	B	C	D	E	P	R 1	R 2	FLAT	WEIGHT (lb)	h	TOE WALL
															CLASS I CONC (CY)
12"	2"	0.07	1 1/2"	4"	2'-0"	4'-0 7/8"	6'-0 7/8"	2'-0"	19 1 5/16"	10 1/8"	9"	3 1/2"	530	12"	.06
15"	2 1/4"	0.07	2"	6"	2'-3"	3'-10"	6'-1"	2'-6"	24 3/16"	12 1/2"	11"	3 1/2"	740	12"	.07
18"	2 1/2"	0.07	2 1/2"	9"	2'-3"	3'-10"	6'-1"	3'-0"	29"	15 1/2"	12"	4"	990	15"	.11
21"	2 3/4"	0.07	2 1/4"	9"	2'-11"	3'-2"	6'-1"	3'-6"	31 5/8"	16 1/2"	13"	4"	1280	15"	.12
24"	3"	0.07	2 1/2"	9 1/2"	3'-7 1/2"	2'-6"	6'-1 1/2"	4'-0"	33 3/16"	16 1 3/16"	14"	4 1/2"	1520	18"	.17
27"	3 1/4"	0.148	2 1/2"	10 1/2"	4'-0"	2'-1 1/2"	6'-1 1/2"	4'-6"	36"	18 9/16"	14 1/2"	4 1/2"	1930	18"	.19
30"	3 1/2"	0.148	3"	1'-0"	4'-6"	1'-7 3/4"	6'-1 3/4"	5'-0"	37"	18 1/2"	15"	5"	2190	21"	.24
36"	4"	0.148	3 1/2"	1'-3"	5'-3"	2'-10 3/4"	8'-1 3/4"	6'-0"	47 1 3/16"	24 3/16"	20"	5 1/2"	4100	21"	.29
42"	4 1/2"	0.148	3 3/4"	1'-9"	5'-3"	2'-11"	8'-2"	6'-6"	53 7/8"	27 1/2"	22"	5 1/2"	5380	24"	.36
48"	5"	0.148	4 1/4"	2'-0"	6'-0"	2'-2"	8'-2"	7'-0"	56 1/2"	28 1/2"	22"	5 3/4"	6550	24"	.39
54"	5 1/2"	0.174	4 3/4"	2'-3"	5'-5"	2'-11"	8'-4"	7'-6"	65 1/2"	33 1/8"	24"	6 1/4"	8040	24"	.42
60"	6"	0.174	5"	2'-6"	5'-0"	3'-3"	8'-3"	8'-0"	72 1/2"	36 1 1/16"	24"	6 3/4"	8750	24"	.44
66"	6 1/2"	0.174	5 1/2"	2'-0"	6'-6"	1'-9"	8'-3"	8'-6"	72"	36 1/8"	24"	7 1/4"	10630	24"	.47
72"	7"	0.174	6"	2'-0"	6'-6"	1'-9"	8'-3"	9'-0"	77 1 3/16"	38 1 5/16"	24"	7 3/4"	12520	24"	.50

GENERAL NOTES

- Flared end sections shall conform to the requirements of ASTM C76 with the exception that dimensions and reinforcement shall be as prescribed in the table above. Circumferential reinforcement may consist of either one cage or two cages of steel. Fiber-reinforced concrete may be substituted for conventional reinforcement in accordance with Structures Design Guidelines, Section 3.17. Compressive strength of concrete shall be 4000 psi. Shop drawings for flared end sections having fiber reinforcing or dimensions other than above must be submitted for approval to the State Drainage Engineer.
- Connections between the flared end section and the pipe culvert may be any of the following types unless otherwise shown on the plans.
 - Joints meeting the requirements of Section 449 of the Standard Specifications (O-Ring Gasket). Flared end section joint dimensions and tolerances shall be identical or compatible to those used in the pipe culvert joint. When pipe culvert and flared end section manufacturers are different, the compatibility of joint designs shall be certified to by the manufacturer of the flared end sections.
 - Joints sealed with preformed plastic gaskets. The gaskets shall meet the requirements of Section 942-2 of the Standard Specifications and the minimum sizes for gaskets shall be as that specified for equivalent sizes of elliptical pipe.
 - Reinforced concrete jackets, as detailed on this drawing. Cost of the reinforced concrete jacket to be included in the contract unit price for the flared end section. When non-coated corrugated metal pipe is called for in the plans, the pipe shall be bituminous coated in the jacketed area as specified on Index 430-001. Bituminous coating to be included in the contract unit price for the pipe culvert. Concrete jacket shall be as specified on Index 430-001. Cost of concrete and reinforcement shall be included in the contract unit price for the pipe culvert.
- Toe walls shall be constructed when shown on the plans or at locations designated by the Engineer. Toe walls are to be cast-in-place with Class I Concrete and paid for under the contract unit price for Flared End Section (Concrete), EA. Reinforcing steel shall also be included in the cost of the Flared End Section (Concrete), EA.
- On skewed pipe culverts the flared end sections shall be placed in line with the pipe culvert. Side slopes shall be warped as required to fit the flared end sections.
- Flared End Section to be paid for under the contract unit price for Flared End Section (Concrete), EA. Sodding shall be in accordance with Index 524-001, and paid for under the contract unit price for Performance Turf, SY.

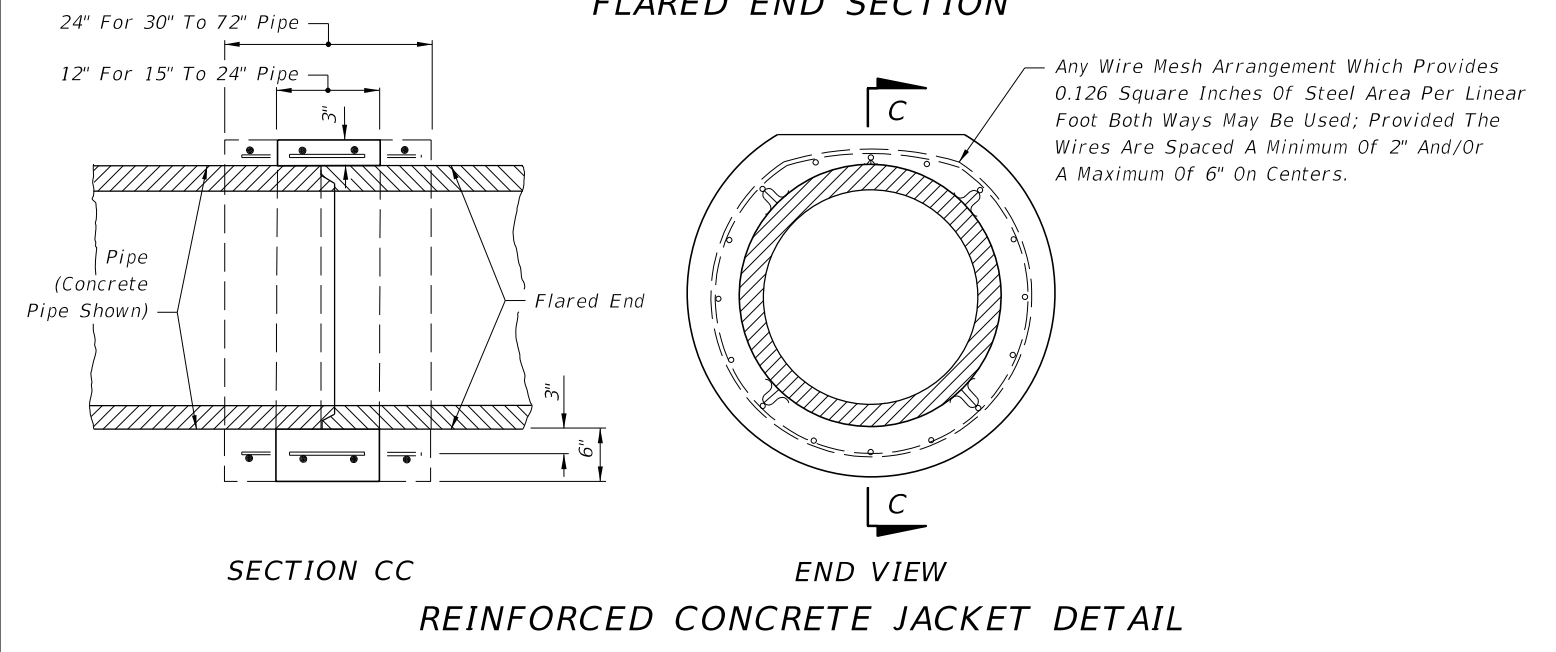

10/30/2018 8:47:26 AM

DIMENSIONS AND QUANTITIES

	D	X	A	B	C	E	F	G	H ■	M				N	5½" CONCRETE SLAB (CY) ▣				SODDING (SY)			
										Single	Double	Triple	Quad.		Single	Double	Triple	Quad.	Single	Double	Triple	Quad.
										Pipe	Pipe	Pipe	Pipe		Pipe	Pipe	Pipe	Pipe	Pipe	Pipe	Pipe	Pipe
1:2 Slope	15"	2'-7"	1.92'	2.18'	4.10'	2.06'	5'	1.22'	2.9'	4.63'	7.21'	9.79'	12.37'	1.19'	0.38	0.58	0.77	0.96	21	24	27	30
	18"	2'-10"	1.97'	2.74'	4.71'	2.56'	6'	1.41'	3.4'	4.92'	7.75'	10.58'	13.42'	1.21'	0.44	0.65	0.87	1.09	22	25	28	31
	24"	3'-5"	2.06'	3.85'	5.91'	3.56'	7'	1.73'	3.4'	5.50'	8.92'	12.33'	15.75'	1.25'	0.54	0.83	1.12	1.42	24	28	32	35
	30"	4'-3"	2.15'	4.95'	7.10'	4.56'	8'	2.00'	3.4'	6.08'	10.33'	14.58'	18.83'	1.29'	0.66	1.09	1.50	1.91	26	31	35	40
	36"	5'-1"	2.25'	6.08'	8.33'	5.56'	9'	2.24'	3.4'	6.67'	11.75'	16.83'	21.92'	1.33'	0.81	1.38	1.95	2.51	28	34	39	45
	42"	6'-0"	2.34'	7.21'	9.55'	6.56'	10'	2.45'	3.4'	7.25'	13.25'	19.25'	25.25'	1.38'	0.97	1.70	2.45	3.19	30	37	43	50
	48"	6'-9"	2.43'	8.33'	10.76'	7.56'	11'	2.65'	3.4'	7.83'	14.58'	21.33'	28.08'	1.42'	1.13	2.04	2.93	3.84	32	39	47	54
	54"	7'-8"	2.52'	9.44'	11.96'	8.56'	12'	2.83'	3.4'	8.42'	16.08'	23.75'	31.42'	1.46'	1.31	2.44	3.58	4.72	34	42	51	59
	60"	8'-6"	2.62'	10.56'	13.18'	9.56'	14'	3.00'	4.4'	9.00'	17.50'	26.00'	34.50'	1.50'	1.51	2.89	4.28	5.68	36	45	55	64
	66"	9'-2"	2.71'	11.68'	14.39'	10.56'	15'	3.18'	4.4'	9.58'	18.75'	27.92'	37.08'	1.54'	1.68	3.25	4.84	6.43	38	48	58	68
72"	10'-0"	2.80'	12.80'	15.60'	11.56'	16'	3.30'	4.4'	10.16'	20.16'	30.16'	40.16'	1.58'	1.89	3.74	5.59	7.45	40	51	62	73	
1:4 Slope	15"	2'-7"	2.27'	4.09'	6.36'	4.03'	8'	1.22'	4.0'	4.63'	7.21'	9.79'	12.37'	1.19'	0.57	0.87	1.15	1.44	23	26	29	32
	18"	2'-10"	2.36'	5.12'	7.48'	5.03'	9'	1.41'	4.0'	4.92'	7.75'	10.58'	13.42'	1.21'	0.66	0.99	1.31	1.65	25	28	31	35
	24"	3'-5"	2.53'	7.18' △	9.71' △	7.03' △	11'	1.73'	4.0'	5.50'	8.92'	12.33'	15.75'	1.25'	0.85	1.30	1.75	2.20	28	32	36	40
	30"	4'-3"	2.70'	9.25'	11.95'	9.03'	13'	2.00'	4.0'	6.08'	10.33'	14.58'	18.83'	1.29'	1.10	1.74	2.39	3.05	31	36	41	46
	36"	5'-1"	2.87'	11.31' ◇	14.18'	11.03' ◇	15'	2.24'	4.0'	6.67'	11.75'	16.83'	21.92'	1.33'	1.32	2.21	3.08	3.96	34	40	46	52
	42"	6'-0"	3.05'	13.37'	16.42'	13.03'	17'	2.45'	4.0'	7.25'	13.25'	19.25'	25.25'	1.38'	1.58	2.76	3.91	5.09	38	44	51	58
	48"	6'-9"	3.22'	15.43'	18.65'	15.03'	19'	2.65'	4.0'	7.83'	14.58'	21.33'	28.08'	1.42'	1.85	3.30	4.73	6.17	41	48	56	63
	54"	7'-8"	3.39'	17.49'	20.88'	17.03'	21'	2.83'	4.0'	8.42'	16.08'	23.75'	31.42'	1.46'	2.14	3.95	5.77	7.58	44	52	61	69
	60"	8'-6"	3.56'	19.55'	23.11'	19.03'	23'	3.00'	4.0'	9.00'	17.50'	26.00'	34.50'	1.50'	2.45	4.66	6.87	9.07	47	56	66	75
	66"	9'-2"	3.73'	21.62'	25.35'	21.03'	25'	3.18'	4.0'	9.58'	18.75'	27.92'	37.08'	1.54'	2.88	5.54	8.18	10.84	49	59	69	80
72"	10'-0"	3.91'	23.68'	27.59'	23.03'	27'	3.30'	4.0'	10.16'	20.16'	30.16'	40.16'	1.58'	3.54	6.61	9.87	13.13	52	63	74	85	

▣ See General Note 5.
See Sheet 5 For 3" Slab Quantities

■ Values shown for estimating pipe quantities and are for information only.

△ 6.42' △ 6.25' Dimensions permitted to allow use of 8' standard pipe lengths.

◇ 10.40' ◇ 10.10' Dimensions permitted to allow use of 12' standard pipe lengths.

△ ◇ Concrete slab shall be deepened to form bridge across crown of pipe. See section below.

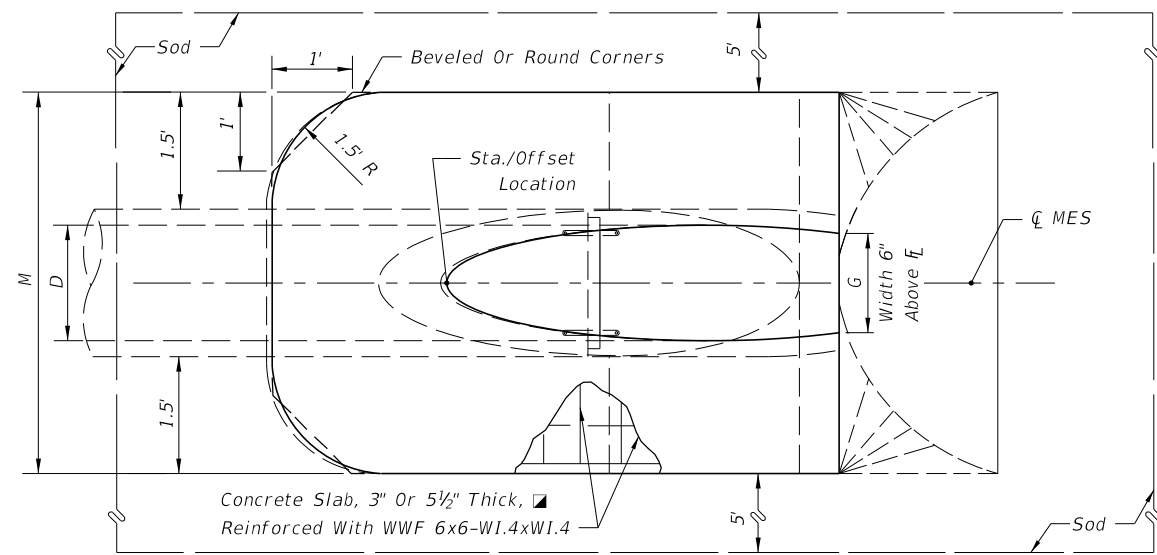

TOP-VIEW SINGLE PIPE

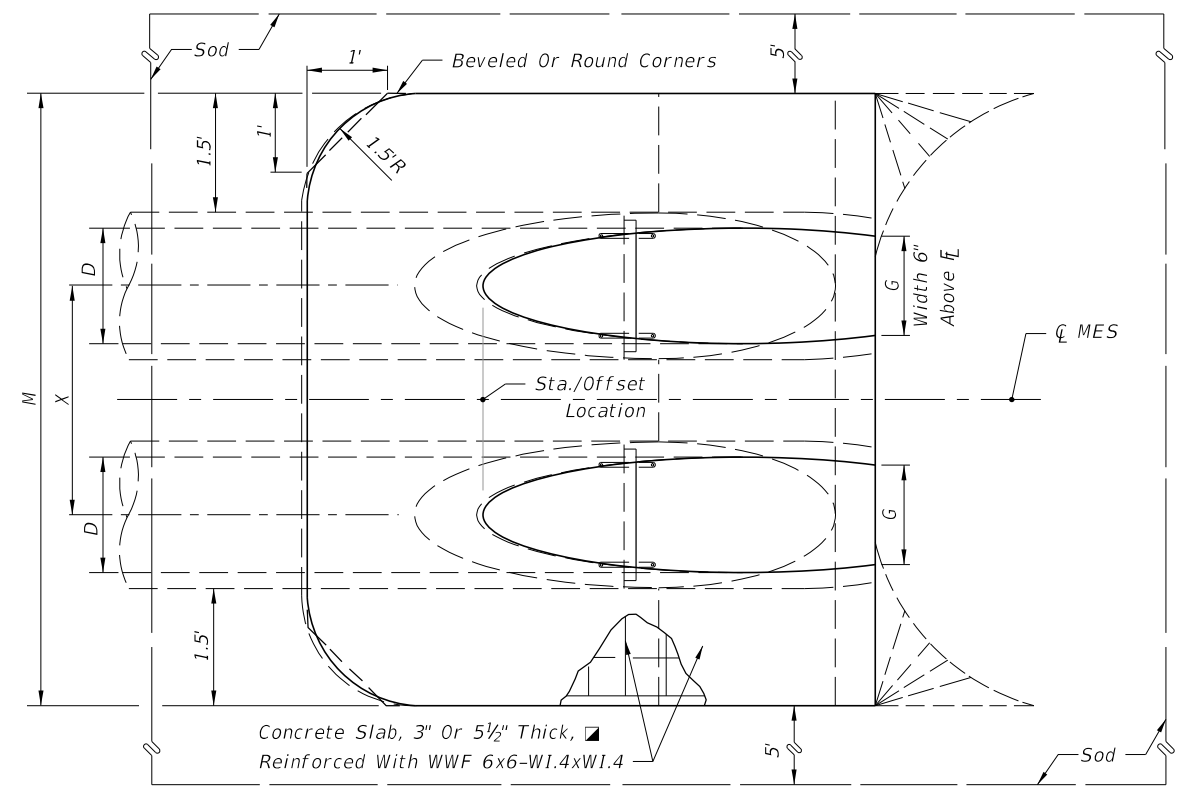

TOP-VIEW MULTIPLE PIPE

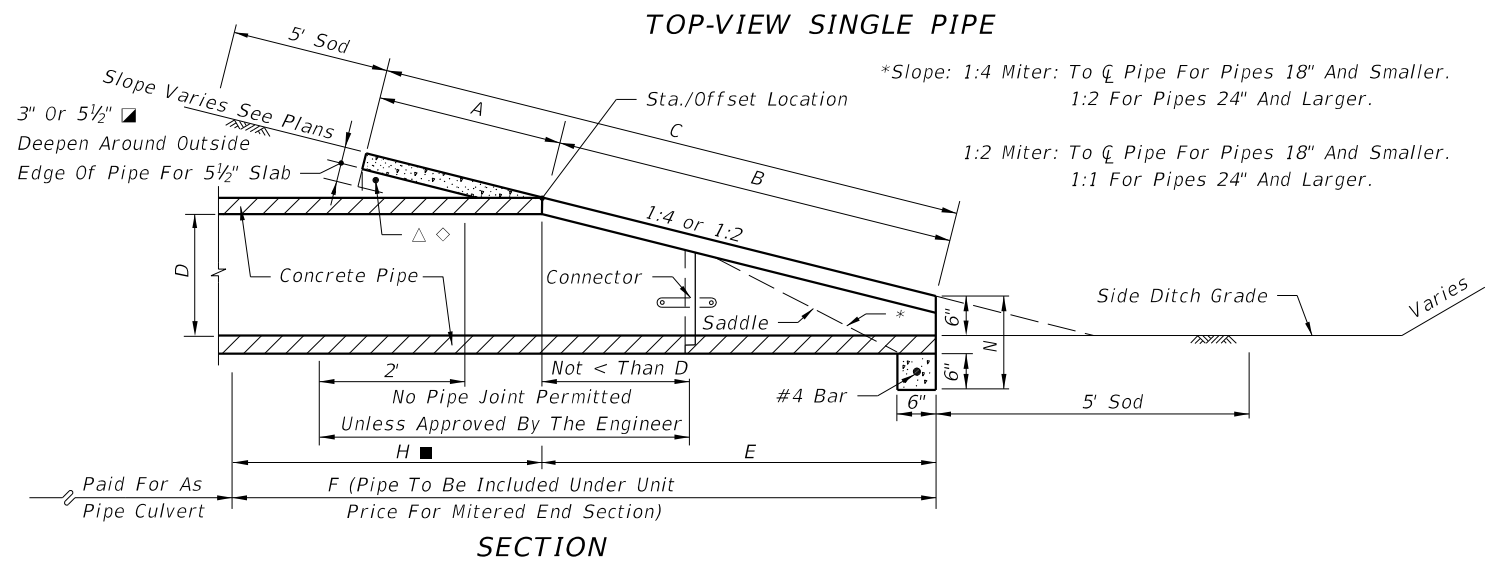

SECTION

NOTE: See sheet 6 for details and notes.

SINGLE AND MULTIPLE ROUND CONCRETE PIPE

10/30/2018 8:47:29 AM

LAST REVISION 11/01/17	REVISION	DESCRIPTION:		FY 2019-20 STANDARD PLANS	CROSS DRAIN MITERED END SECTION	INDEX 430-021	SHEET 1 of 6
---------------------------	----------	--------------	--	------------------------------	---------------------------------	------------------	-----------------

DIMENSIONS AND QUANTITIES

	D	X	A	B	C	E	F	G	H ■	M				N	5½" CONCRETE SLAB (CY) ▣				SODDING (SY)			
										Single Pipe	Double Pipe	Triple Pipe	Quad. Pipe		Single Pipe	Double Pipe	Triple Pipe	Quad. Pipe	Single Pipe	Double Pipe	Triple Pipe	Quad. Pipe
1:2 Slope	15"	2'-7"	2.5'	1.68'	4.18'	1.5'	5.0'	1.23'	3.5'	4.33'	6.92'	9.50'	12.08'	1.04'	0.35	0.54	0.74	0.94	21	24	27	29
	18"	2'-10"	2.5'	2.24'	4.74'	2.0'	6.0'	1.41'	4'	4.58'	7.42'	10.25'	13.08'	1.04'	0.38	0.62	0.87	1.12	22	25	28	31
	24"	3'-5"	2.5'	3.35'	5.85'	3.0'	7.0'	1.73'	4'	5.08'	8.50'	11.92'	15.33'	1.04'	0.47	0.76	1.05	1.34	23	27	31	35
	30"	4'-3"	2.5'	4.47'	6.97'	4.0'	8.0'	2.00'	4'	5.58'	9.83'	14.08'	18.33'	1.04'	0.57	0.96	1.37	1.77	25	30	35	39
	36"	5'-1"	2.5'	5.59'	8.09'	5.0'	9.0'	2.24'	4'	6.08'	11.17'	16.25'	21.33'	1.04'	0.67	1.19	1.72	2.26	27	33	38	44
	42"	6'-0"	2.5'	6.71'	9.21'	6.0'	10.0'	2.45'	4'	6.58'	12.58'	18.58'	24.58'	1.04'	0.78	1.48	2.17	2.87	29	36	42	49
	48"	6'-9"	2.5'	7.83'	10.33'	7.0'	11.0'	2.65'	4'	7.08'	13.83'	20.58'	27.33'	1.04'	0.89	1.71	2.54	3.36	31	38	46	53
1:4 Slope	15"	2'-7"	2.5'	3.09'	5.59'	3.0'	7.0'	1.23'	4'	4.33'	6.92'	9.50'	12.08'	1.04'	0.44	0.68	0.91	1.15	22	25	28	31
	18"	2'-10"	2.5'	4.12'	6.62'	4.0'	8.0'	1.41'	4'	4.58'	7.42'	10.25'	13.08'	1.04'	0.49	0.77	1.03	1.31	24	27	30	33
	24"	3'-5"	2.5'	6.18'	8.68'	6.0'	10.0'	1.73'	4'	5.08'	8.50'	11.92'	15.33'	1.04'	0.65	1.09	1.38	1.77	27	30	34	38
	30"	4'-3"	2.5'	8.25'	10.75'	8.0'	12.0'	2.00'	4'	5.58'	9.83'	14.08'	18.33'	1.04'	0.81	1.34	1.90	2.44	29	34	39	44
	36"	5'-1"	2.5'	10.31'	12.81'	10.0'	14.0'	2.24'	4'	6.08'	11.17'	16.25'	21.33'	1.04'	0.97	1.68	2.41	3.14	32	38	44	49
	42"	6'-0"	2.5'	12.37'	14.87'	12.0'	16.0'	2.45'	4'	6.58'	12.58'	18.58'	24.58'	1.04'	1.13	2.08	3.06	4.02	35	42	48	55
	48"	6'-9"	2.5'	14.43'	16.93'	14.0'	18.0'	2.65'	4'	7.08'	13.83'	20.58'	27.33'	1.04'	1.29	2.49	3.69	4.88	38	46	53	60
	54"	7'-8"	2.5'	16.49'	18.99'	16.0'	20.0'	2.83'	4'	7.58'	15.25'	22.92'	30.58'	1.04'	1.48	2.98	4.47	5.98	41	49	58	66
60"	8'-6"	2.5'	18.55'	21.05'	18.0'	22.0'	3.00'	4'	8.08'	16.58'	25.08'	33.58'	1.04'	1.66	3.49	5.31	7.13	44	53	63	72	

▣ See General Note 5.
See Sheet 5
For 3" Slab Quantities

■ Values shown for estimating pipe quantities and are for information only

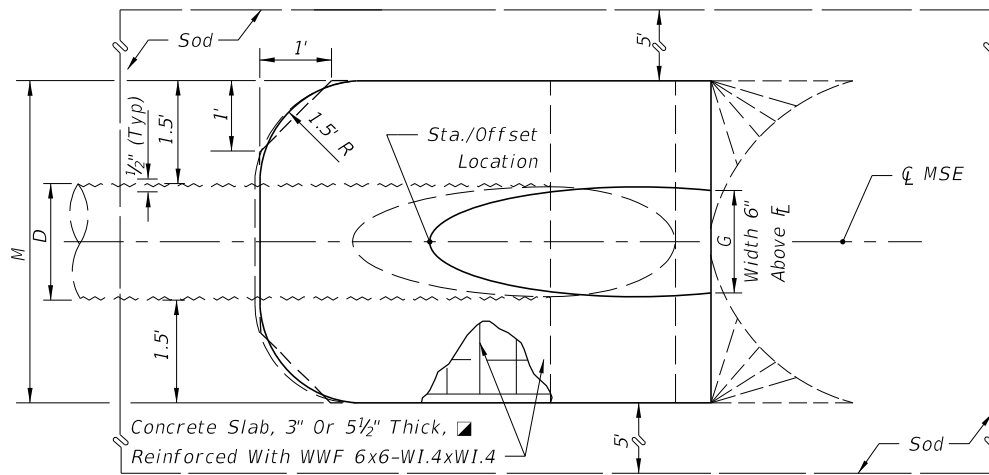

TOP VIEW-SINGLE PIPE

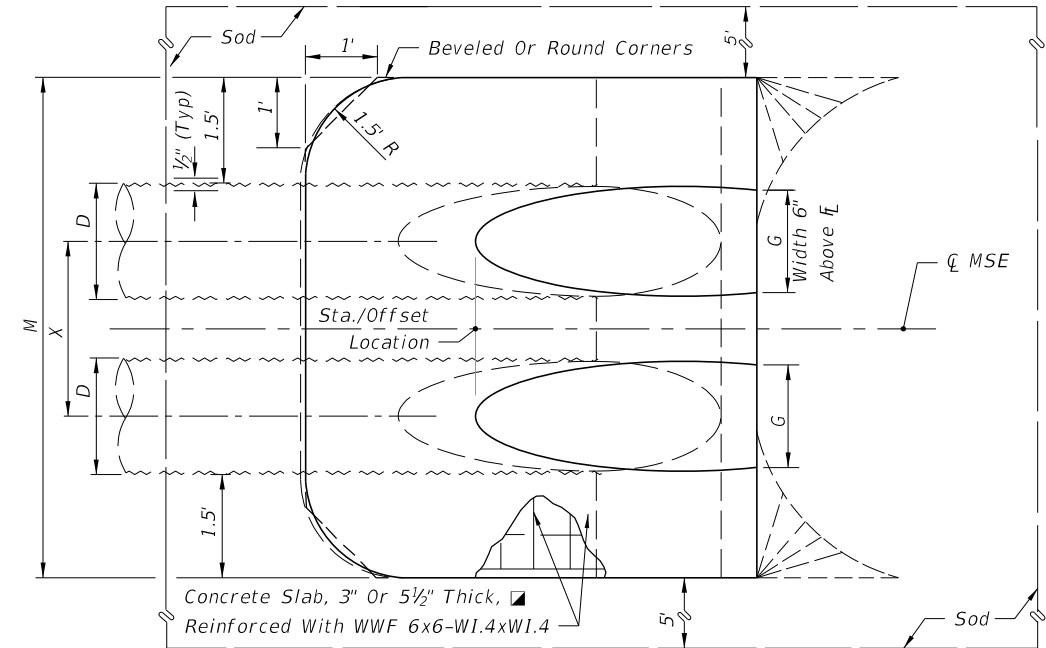

TOP VIEW-MULTIPLE PIPE

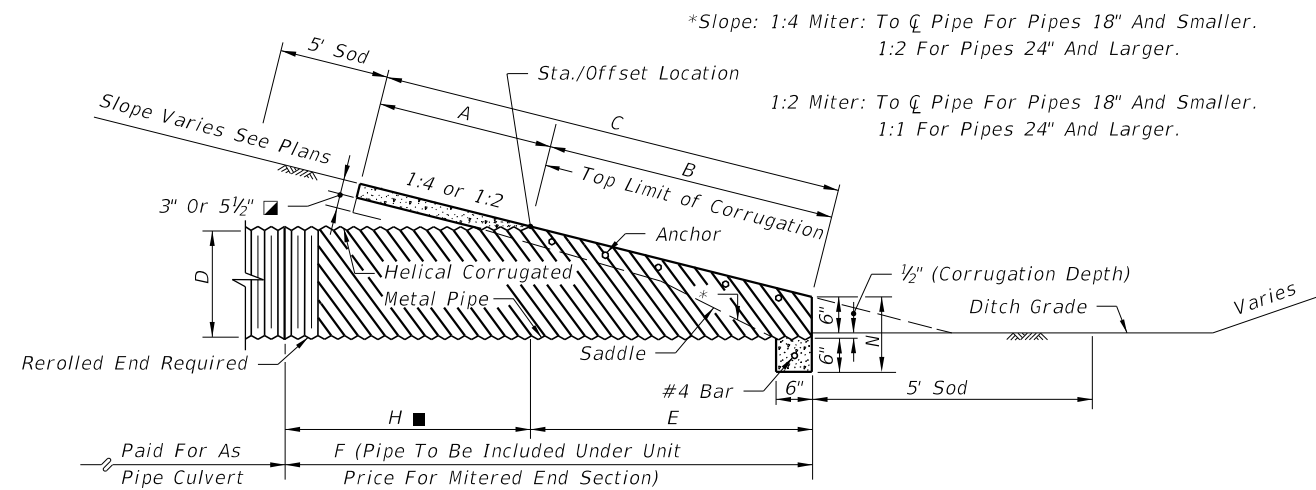

SECTION

NOTE: See Sheet 6 For Details And Notes.

SINGLE AND MULTIPLE ROUND CORRUGATED METAL PIPE

10/30/2018 8:47:50 AM

LAST REVISION 11/01/17	REVISION	DESCRIPTION:	 FY 2019-20 STANDARD PLANS	CROSS DRAIN MITERED END SECTION	INDEX 430-021	SHEET 2 of 6
---------------------------	----------	--------------	----------------------------------	---------------------------------	------------------	-----------------

1974 AASHTO			DIMENSIONS AND QUANTITIES																	■ See General Note 5. See Sheet 5 For 3" Slab Quantities ■ Values shown for estimating pipe quantities and are for information.			
SPAN	RISE	X	A	B	C	E	F	G	H ■	M				N	5½" CONCRETE SLAB (CY) ▽				SODDING (SY)				
										Single Pipe	Double Pipe	Triple Pipe	Quad. Pipe		Single Pipe	Double Pipe	Triple Pipe	Quad. Pipe					
1:2 Slope	17"	13"	2'-6"	2.5'	1.30'	3.80'	1.17'	4'	1.39'	2.8'	4.50'	7.00'	9.50'	12.00'	1.04'	0.41	0.61	0.81	1.02	21	23	26	29
	21"	15"	2'-10"	2.5'	1.68'	4.17'	1.50'	5'	1.76'	3.5'	4.83'	7.67'	10.50'	13.33'	1.04'	0.43	0.66	0.88	1.10	22	25	28	31
	28"	20"	3'-5"	2.5'	2.61'	5.11'	2.33'	6'	2.22'	3.7'	5.42'	8.83'	12.25'	15.67'	1.04'	0.51	0.78	1.06	1.33	23	27	30	34
	35"	24"	4'-0"	2.5'	3.35'	5.85'	3.00'	7'	2.55'	4.0'	6.00'	10.00'	14.00'	18.00'	1.04'	0.57	0.90	1.22	1.55	24	29	33	38
	42"	29"	4'-9"	2.5'	4.29'	6.79'	3.83'	8'	2.97'	4.2'	6.58'	11.33'	16.08'	20.83'	1.04'	0.64	1.04	1.46	1.87	26	31	37	42
	49"	33"	5'-6"	2.5'	5.03'	7.53'	4.50'	9'	3.34'	4.5'	7.17'	12.67'	18.17'	23.67'	1.04'	0.73	1.23	1.72	2.22	28	34	40	46
	57"	38"	6'-4"	2.5'	5.96'	8.46'	5.33'	10'	3.65'	4.7'	7.83'	14.17'	20.50'	26.83'	1.04'	0.83	1.44	2.04	2.64	29	36	44	51
	64"	43"	7'-1"	2.5'	6.89'	9.39'	6.17'	11'	3.89'	4.8'	8.42'	15.50'	22.58'	29.67'	1.04'	0.95	1.67	2.39	3.11	31	39	47	55
71"	47"	7'-10"	2.5'	7.64'	10.14'	6.83'	12'	4.14'	5.2'	9.00'	16.83'	24.67'	32.50'	1.04'	1.05	1.89	2.74	3.57	33	41	50	59	
1:4 Slope	17"	13"	2'-6"	2.5'	2.41'	4.91'	2.33'	7'	1.39'	4.7'	4.50'	7.00'	9.50'	12.00'	1.04'	0.48	0.71	0.95	1.18	22	25	27	30
	21"	15"	2'-10"	2.5'	3.09'	5.59'	3.00'	8'	1.76'	5.0'	4.83'	7.67'	10.50'	13.33'	1.04'	0.52	0.80	1.09	1.31	23	26	29	32
	28"	20"	3'-5"	2.5'	4.81'	7.31'	4.67'	9'	2.22'	4.3'	5.42'	8.83'	12.25'	15.67'	1.04'	0.61	0.92	1.27	1.59	25	29	33	37
	35"	24"	4'-0"	2.5'	6.18'	8.68'	6.00'	11'	2.55'	5.0'	6.00'	10.00'	14.00'	18.00'	1.04'	0.73	1.14	1.55	1.97	28	32	37	41
	42"	29"	4'-9"	2.5'	7.90'	10.40'	7.67'	12'	2.97'	4.3'	6.58'	11.33'	16.08'	20.83'	1.04'	0.87	1.39	1.92	2.45	30	35	41	46
	49"	33"	5'-6"	2.5'	9.28'	11.78'	9.00'	14'	3.34'	5.0'	7.17'	12.67'	18.17'	23.67'	1.04'	1.00	1.66	2.30	2.96	32	38	45	51
	57"	38"	6'-4"	2.5'	11.00'	13.50'	10.67'	16'	3.65'	5.3'	7.83'	14.17'	20.50'	26.83'	1.04'	1.18	2.00	2.82	3.64	35	42	49	56
	64"	43"	7'-1"	2.5'	12.71'	15.21'	12.33'	17'	3.89'	4.7'	8.42'	15.50'	22.58'	29.67'	1.04'	1.36	2.39	3.38	4.38	38	45	53	61
71"	47"	7'-10"	2.5'	14.09'	16.59'	13.67'	19'	4.14'	5.3'	9.00'	16.83'	24.67'	32.50'	1.04'	1.50	2.65	3.81	4.97	40	48	57	66	

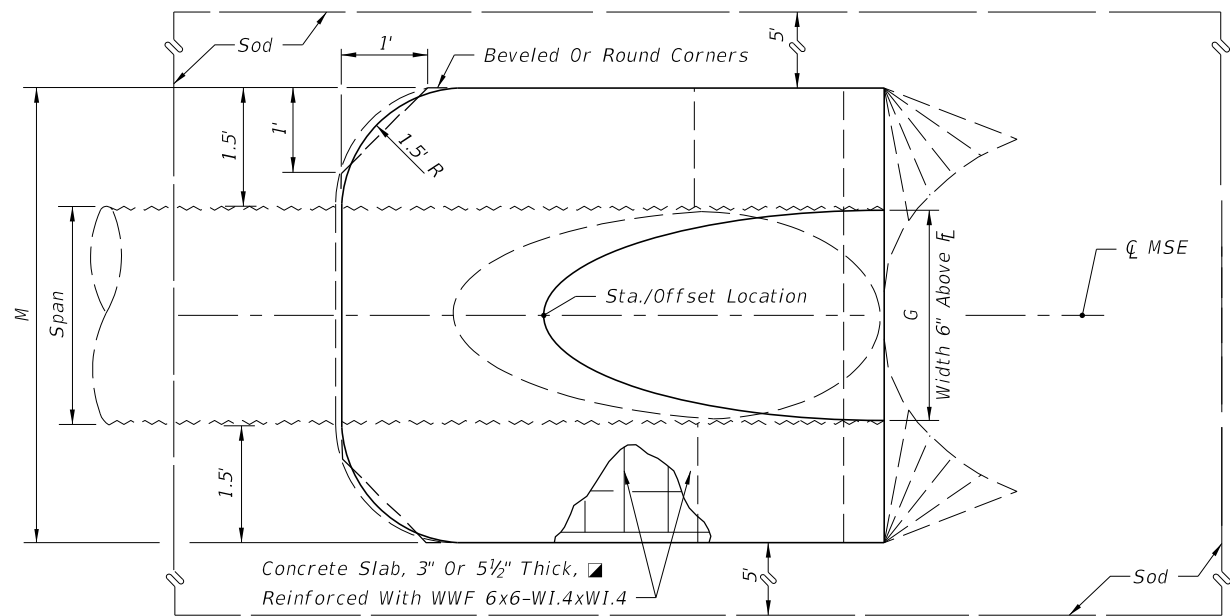

TOP VIEW-SINGLE PIPE

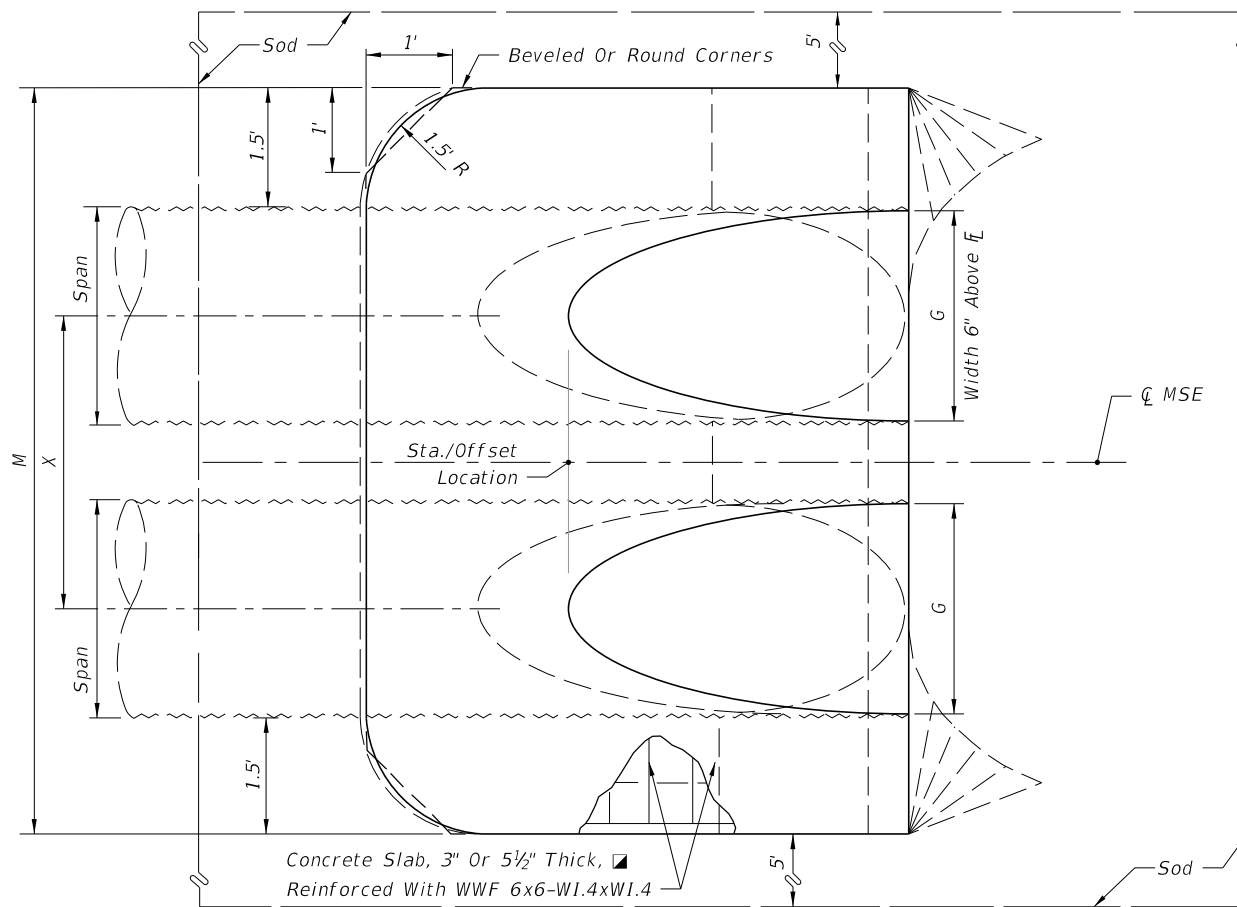

TOP VIEW-MULTIPLE PIPE

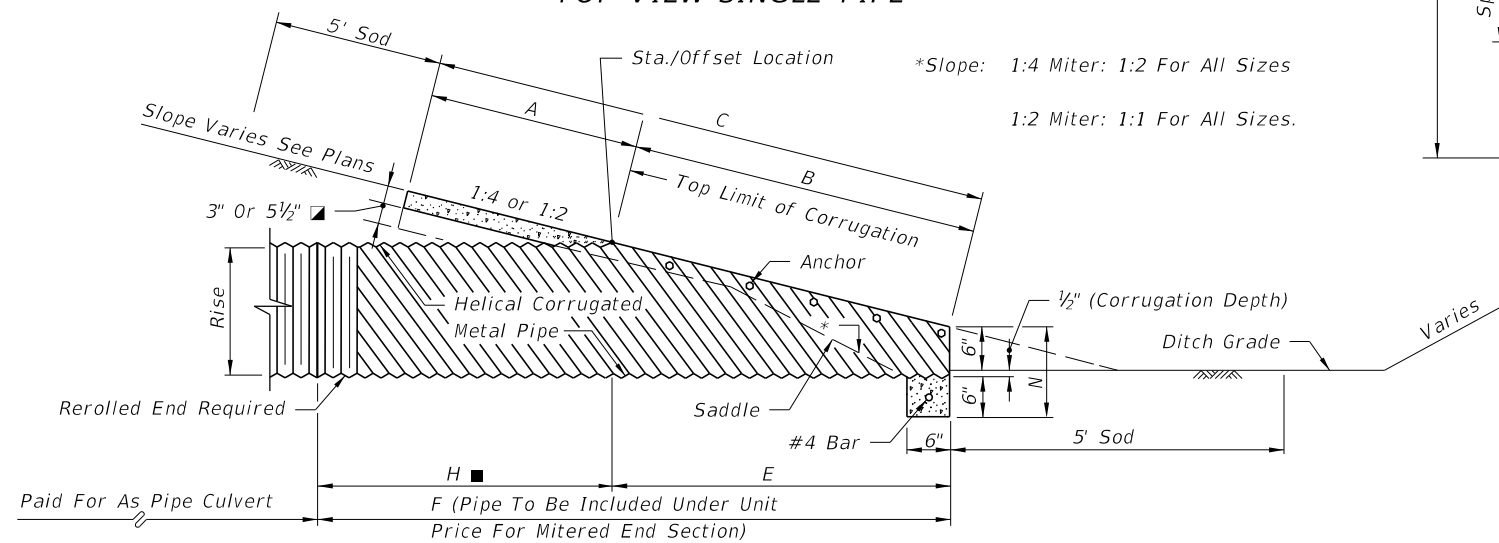

SECTION

SINGLE AND MULTIPLE CORRUGATED METAL PIPE-ARCH

NOTE: See Sheet 6 For Details And Notes.

10/30/2018 8:47:54 AM

LAST REVISION 11/01/17

DESCRIPTION:



FY 2019-20 STANDARD PLANS

CROSS DRAIN MITERED END SECTION

INDEX 430-021

SHEET 3 of 6

DIMENSIONS & QUANTITIES

Rise R	Span S	X	A	B	C	E	F	G	H	M				N	5 1/2" CONC. SLAB (CY) ▣				SODDING (SY)				
										Single Pipe	Double Pipe	Triple Pipe	Quad. Pipe		Single Pipe	Double Pipe	Triple Pipe	Quad. Pipe	Single Pipe	Double Pipe	Triple Pipe	Quad. Pipe	
1:2 Slope	12"	18"	2'-10"	1.97'	1.62'	3.59'	1.56'	4'	1.50'	2.4'	4.92'	7.75'	10.58'	13.42'	1.21'	0.30	0.49	0.67	0.85	21	24	27	30
	14"	23"	3'-4"	2.01'	1.99'	4.00'	1.89'	5'	1.90'	3.1'	5.38'	8.71'	12.04'	15.38'	1.23'	0.37	0.59	0.81	1.02	22	26	29	33
	19"	30"	4'-0"	2.11'	2.92'	5.03'	2.73'	6'	2.37'	3.3'	6.04'	10.04'	14.04'	18.04'	1.27'	0.50	0.80	1.09	1.39	24	28	33	37
	24"	38"	5'-0"	2.20'	3.85'	6.05'	3.56'	7'	2.85'	3.4'	6.79'	11.79'	16.79'	21.79'	1.31'	0.62	1.03	1.45	1.86	26	31	37	42
	29"	45"	5'-11"	2.34'	4.79'	7.13'	4.39'	8'	3.19'	3.6'	7.50'	13.42'	19.33'	25.25'	1.38'	0.75	1.30	1.84	2.39	28	34	41	47
	34"	53"	7'-0"	2.43'	5.72'	8.15'	5.23'	9'	3.57'	3.8'	8.25'	15.25'	22.25'	29.25'	1.42'	0.90	1.61	2.32	3.03	30	37	45	53
	38"	60"	7'-10"	2.52'	6.46'	8.98'	5.89'	9'	3.95'	3.1'	8.92'	16.75'	24.58'	32.42'	1.46'	1.03	1.89	2.74	3.60	31	40	49	57
	43"	68"	8'-11"	2.62'	7.39'	10.01'	6.73'	10'	4.28'	3.3'	9.67'	18.58'	27.50'	36.42'	1.50'	1.19	2.26	3.33	4.40	33	43	53	63
	48"	76"	9'-11"	2.71'	8.33'	11.04'	7.56'	11'	4.59'	3.4'	10.42'	20.33'	30.25'	40.17'	1.54'	1.38	2.65	3.93	5.21	35	46	57	68
	53"	83"	10'-8"	2.80'	9.26'	12.06'	8.39'	12'	4.77'	3.6'	11.08'	21.75'	32.42'	43.08'	1.58'	1.55	3.03	4.50	5.96	37	49	61	73
58"	91"	11'-8"	2.90'	10.19'	13.09'	9.23'	13'	5.01'	3.8'	11.83'	23.50'	35.17'	46.83'	1.63'	1.75	3.47	5.20	6.93	39	52	65	78	
1:4 Slope	12"	18"	2'-10"	2.36'	3.06'	5.42'	3.03'	5'	1.50'	2.0'	4.92'	7.75'	10.58'	13.42'	1.21'	0.45	0.68	0.92	1.14	23	26	29	32
	14"	23"	3'-4"	2.44'	3.75'	6.19'	3.70'	6'	1.90'	2.3'	5.38'	8.71'	12.04'	15.38'	1.23'	0.53	0.83	1.13	1.42	24	28	32	35
	19"	30"	4'-0"	2.62'	5.47'	8.09'	5.36'	8'	2.37'	2.6'	6.04'	10.04'	14.04'	18.04'	1.27'	0.74	1.15	1.57	1.98	27	32	36	40
	24"	38"	5'-0"	2.79'	7.18'	9.97'	7.03'	10'	2.85'	3.0'	6.79'	11.79'	16.79'	21.79'	1.31'	0.97	1.57	2.19	2.81	30	36	41	47
	29"	45"	5'-11"	3.05'	8.90'	11.95'	8.70'	12'	3.19'	3.3'	7.50'	13.42'	19.33'	25.25'	1.38'	1.22	2.07	2.92	3.77	33	40	46	53
	34"	53"	7'-0"	3.22'	10.62'	13.84'	10.36'	13'	3.57'	2.6'	8.25'	15.25'	22.25'	29.25'	1.42'	1.48	2.62	3.77	4.92	36	44	52	59
	38"	60"	7'-10"	3.39'	11.99'	15.38'	11.70'	15'	3.95'	3.3'	8.92'	16.75'	24.58'	32.42'	1.46'	1.72	3.12	4.53	5.92	38	47	56	65
	43"	68"	8'-11"	3.56'	13.71'	17.27'	13.36'	17'	4.28'	3.6'	9.67'	18.58'	27.50'	36.42'	1.50'	2.02	3.78	5.56	7.32	41	51	61	71
	48"	76"	9'-11"	3.73'	15.43'	19.16'	15.03'	19'	4.59'	4.0'	10.42'	20.33'	30.25'	40.17'	1.54'	2.34	4.49	6.64	8.79	44	55	66	77
	53"	83"	10'-8"	3.91'	17.15'	21.06'	16.70'	20'	4.77'	3.3'	11.08'	21.75'	32.42'	43.08'	1.58'	2.66	5.17	7.66	10.16	47	59	71	83
58"	91"	11'-8"	4.08'	18.87'	22.95'	18.36'	22'	5.01'	3.6'	11.83'	23.50'	35.17'	46.83'	1.63'	3.02	5.98	8.95	11.90	50	63	76	89	

▣ See General Note 3.
See Sheet 5 For 3" Slab Quantities

■ Values shown for estimating pipe quantities and are for information only.

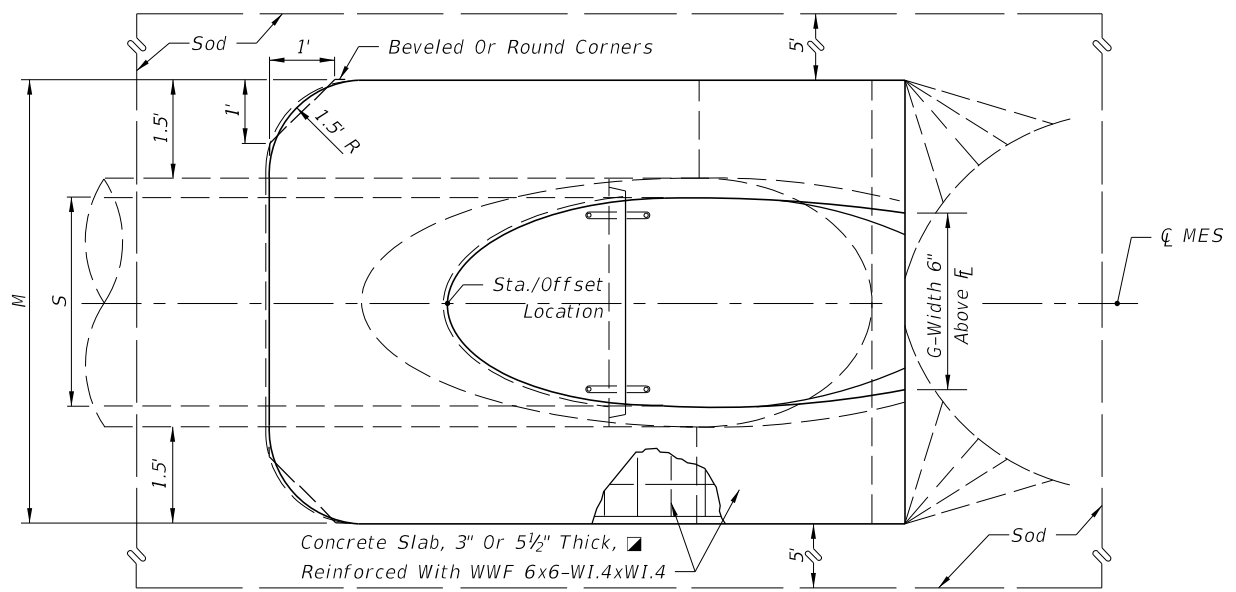

TOP VIEW-SINGLE PIPE

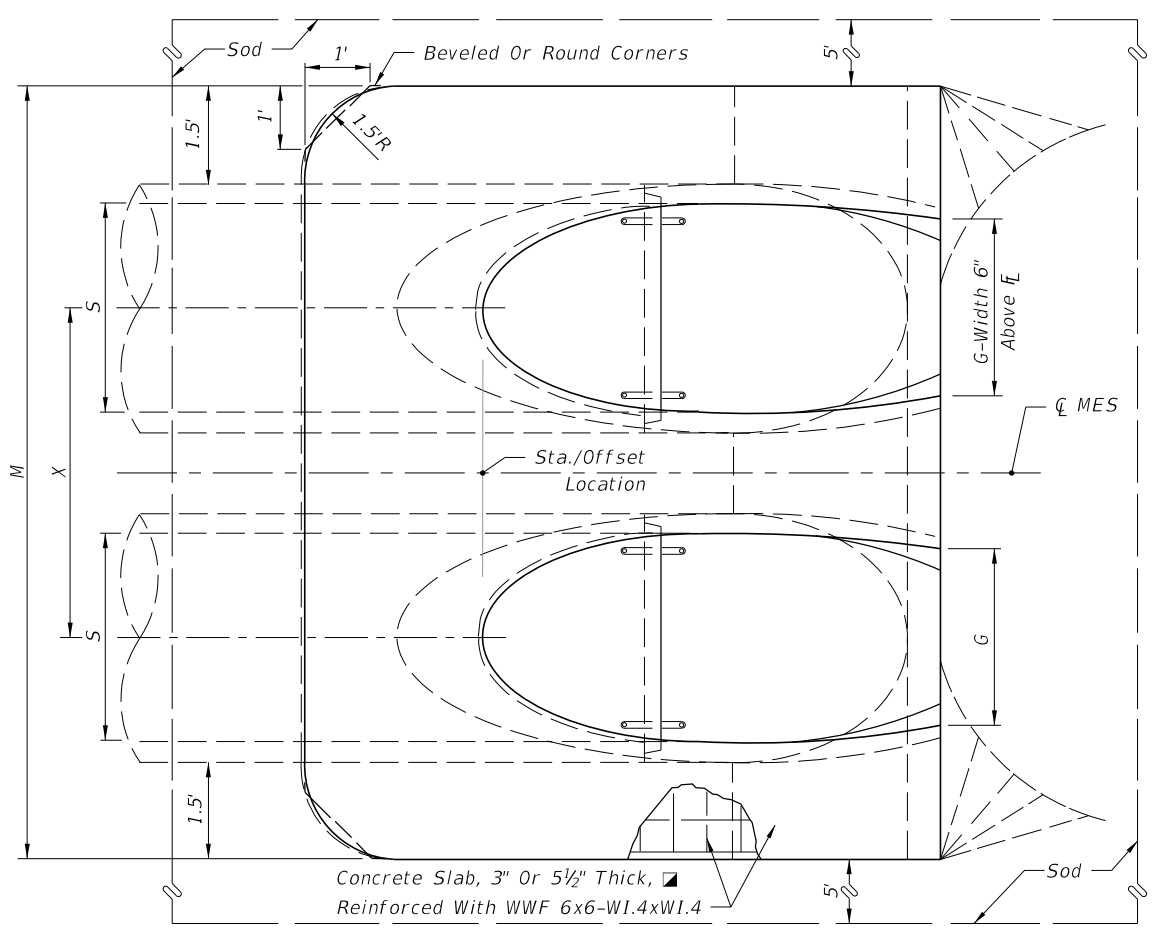

NOTE: See Sheet 6 For Details And Notes.

TOP VIEW - MULTIPLE PIPE

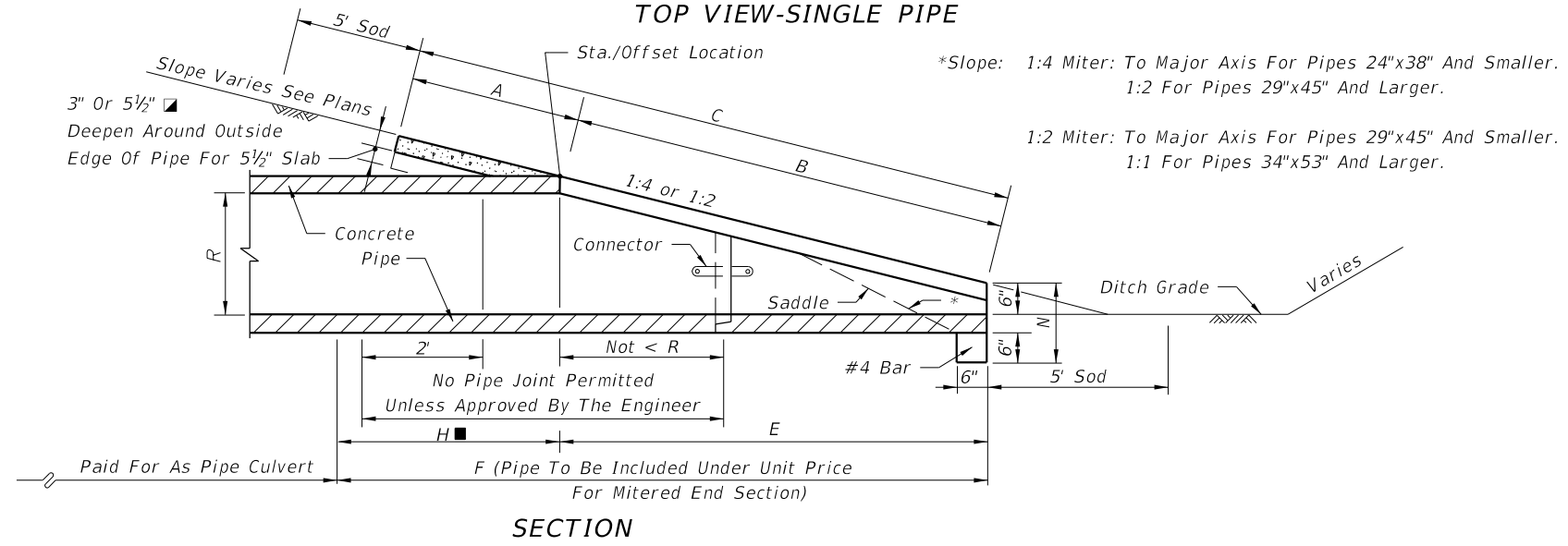

SECTION

SINGLE AND MULTIPLE ELLIPTICAL CONCRETE PIPE

10/30/2018 8:47:58 AM

LAST REVISION 11/01/17	DESCRIPTION:	FDOT FY 2019-20 STANDARD PLANS	CROSS DRAIN MITERED END SECTION	INDEX 430-021	SHEET 4 of 6
---------------------------	--------------	--------------------------------------	---------------------------------	------------------	-----------------

QUANTITIES FOR 3" THICK CONCRETE SLABS (CY)

	D	ROUND-CONCRETE			
		Single Pipe	Double Pipe	Triple Pipe	Quad. Pipe
1:2 Slope	15"	0.27	0.41	0.54	0.67
	18"	0.31	0.45	0.60	0.75
	24"	0.39	0.59	0.79	1.00
	30"	0.46	0.76	1.04	1.32
	36"	0.55	0.94	1.33	1.71
	42"	0.66	1.15	1.66	2.15
	48"	0.76	1.37	1.96	2.57
	54"	0.87	1.62	2.38	3.14
	60"	0.99	1.90	2.81	3.73
	66"	1.11	2.15	3.21	4.27
72"	1.24	2.46	3.68	4.90	
1:4 Slope	15"	0.40	0.61	0.80	1.00
	18"	0.47	0.69	0.91	1.14
	24"	0.60	0.90	1.21	1.52
	30"	0.76	1.19	1.63	2.07
	36"	0.89	1.48	2.05	2.63
	42"	1.05	1.82	2.57	3.34
	48"	1.21	2.15	3.07	4.00
	54"	1.39	2.55	3.72	4.88
	60"	1.59	3.02	4.44	5.86
	66"	1.91	3.66	5.40	7.15
72"	2.12	4.18	6.24	8.30	

	D	ROUND-CMP			
		Single Pipe	Double Pipe	Triple Pipe	Quad. Pipe
1:2 Slope	15"	0.24	0.37	0.51	0.64
	18"	0.26	0.43	0.61	0.78
	24"	0.32	0.52	0.72	0.91
	30"	0.38	0.64	0.91	1.18
	36"	0.44	0.78	1.13	1.48
	42"	0.51	0.96	1.41	1.87
	48"	0.57	1.09	1.63	2.15
	54"	0.65	1.32	1.99	2.66
	60"	0.71	1.49	2.28	3.07
1:4 Slope	15"	0.31	0.47	0.63	0.79
	18"	0.34	0.53	0.71	0.90
	24"	0.44	0.69	0.92	1.18
	30"	0.53	0.88	1.25	1.60
	36"	0.62	1.07	1.53	2.00
	42"	0.71	1.30	1.92	2.52
	48"	0.80	1.54	2.29	3.02
	54"	0.91	1.83	2.74	3.67
	60"	1.02	2.15	3.27	4.39

	Span	Rise	CMP-ARCH			
			Single Pipe	Double Pipe	Triple Pipe	Quad. Pipe
1:2 Slope	17"	13"	0.33	0.49	0.65	0.81
	21"	15"	0.33	0.50	0.67	0.83
	28"	20"	0.37	0.56	0.76	0.95
	35"	24"	0.40	0.62	0.84	1.07
	42"	29"	0.43	0.70	0.98	1.25
	49"	33"	0.49	0.82	1.15	1.48
	57"	38"	0.55	0.95	1.35	1.75
	64"	43"	0.62	1.10	1.57	2.05
	71"	47"	0.69	1.24	1.80	2.35
1:4 Slope	17"	13"	0.38	0.56	0.74	0.92
	21"	15"	0.39	0.59	0.80	0.95
	28"	20"	0.43	0.64	0.88	1.10
	35"	24"	0.49	0.77	1.05	1.33
	42"	29"	0.57	0.92	1.27	1.62
	49"	33"	0.65	1.08	1.50	1.93
	57"	38"	0.76	1.30	1.83	2.37
	64"	43"	0.87	1.55	2.18	2.83
	71"	47"	0.95	1.68	2.43	3.17

	Rise	Span	ELLIPTICAL-CONCRETE			
			Single Pipe	Double Pipe	Triple Pipe	Quad. Pipe
1:2 Slope	12"	18"	0.19	0.33	0.45	0.57
	14"	23"	0.25	0.40	0.55	0.69
	19"	30"	0.34	0.55	0.75	0.95
	24"	38"	0.43	0.71	1.00	1.28
	29"	45"	0.52	0.90	1.27	1.65
	34"	53"	0.62	1.11	1.60	2.09
	38"	60"	0.70	1.29	1.87	2.46
	43"	68"	0.81	1.54	2.26	2.99
	48"	76"	0.93	1.79	2.66	3.53
	53"	83"	1.04	2.04	3.03	4.02
58"	91"	1.17	2.33	3.49	4.66	
1:4 Slope	12"	18"	0.30	0.45	0.61	0.76
	14"	23"	0.36	0.56	0.76	0.95
	19"	30"	0.51	0.79	1.08	1.36
	24"	38"	0.68	1.10	1.53	1.96
	29"	45"	0.86	1.45	2.04	2.63
	34"	53"	1.02	1.81	2.60	3.39
	38"	60"	1.18	2.14	3.10	4.05
	43"	68"	1.38	2.58	3.79	4.99
	48"	76"	1.59	3.05	4.51	5.97
	53"	83"	1.80	3.50	5.19	6.88
58"	91"	2.04	4.04	6.05	8.05	

10/30/2018 8:48:02 AM

GENERAL NOTES

1. Unless otherwise designated in the plans, concrete pipe mitered end sections may be used with any type of cross drain pipe; corrugated steel pipe mitered end sections may be used with any type of cross drain pipe except aluminum pipe; and, corrugated aluminum mitered end sections may be used with any type of cross drain pipe except steel pipe. When bituminous coated metal pipe is specified for cross drain pipe, construct the mitered end sections with like pipe or concrete pipe. When the mitered end section pipe is dissimilar to the cross drain pipe, construct a concrete jacket in accordance with Index 430-001.
2. Use either corrugated metal or concrete mitered end sections for corrugated polyethylene pipe (HDPE), polyvinyl-chloride pipe (PVC) and polypropylene pipe (PPP). When used in conjunction with corrugated mitered end sections, make connection using either a formed metal band specifically designated to join HDPE or PVC pipe, with metal pipe or other coupler approved by the State Drainage Engineer. When used in conjunction with a concrete mitered end sections, concrete jacket constructed in accordance with Index 430-001.
3. Class NS concrete cast-in-place reinforced slabs are required for all sizes of cross drain pipes. Unless 3" thickness called for in plans, construct slabs at 5 1/2" thick.
4. Select lengths of concrete pipe that avoid excessive connections in the assembly of the mitered end section.
5. Repair corrugated metal pipe galvanizing that is damaged during beveling and perforating.
6. Prior to placing concrete slab apply a bituminous coating to any portion of corrugated metal pipe in direct contact with concrete. Extend the coating 12" beyond the concrete slab.
7. When existing multiple cross drain pipes are spaced other than the dimensions shown in this Index, have nonparallel axes, or non-uniform sections, either construct the mitered end sections separately as single pipe or collectively as multiple pipe end sections as directed by the Engineer.

DESIGN NOTES

1. Mitered end sections for pipe sizes 15", 18" and 24" round or equivalent pipe arch or elliptical pipe are permitted within the clear zone. When the slope intersection permits, the mitered end section may be located with the culvert opening as close as 8' beyond the outside edge of the shoulder.
2. Include slope and ditch transitions when the normal roadway slope must be flattened to place end section outside clear zone. See Slope and Ditch Transitions detail.

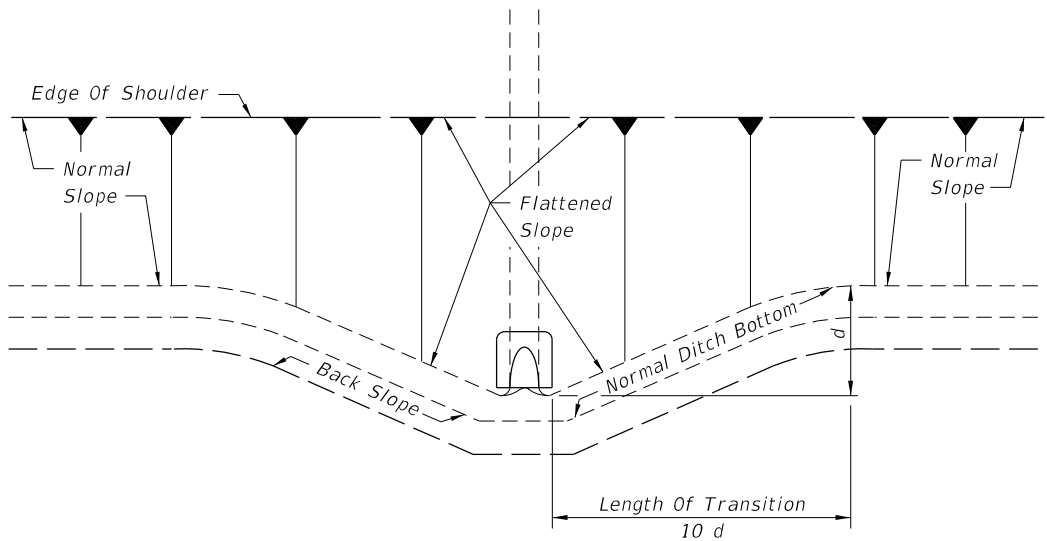

PLAN NOTE: See General Note 4
SLOPE AND DITCH TRANSITIONS

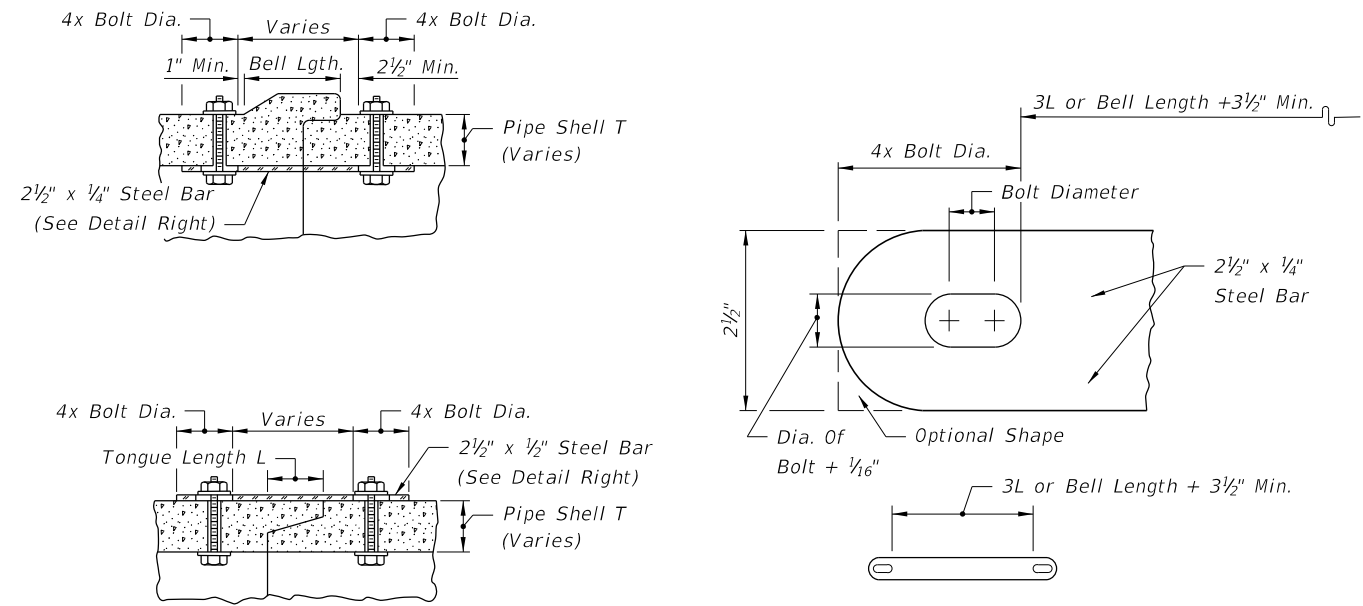

All bars, bolts, nuts and washers are to be galvanized steel.
Bolt diameters shall be 3/8" for 15" to 36" pipe and 5/8" for 42" to 72" pipe.
Two connectors required per joint, located 60° right and left of bottom center of pipe.
Bolt holes in pipe shell are to be drilled.

CONCRETE PIPE CONNECTOR

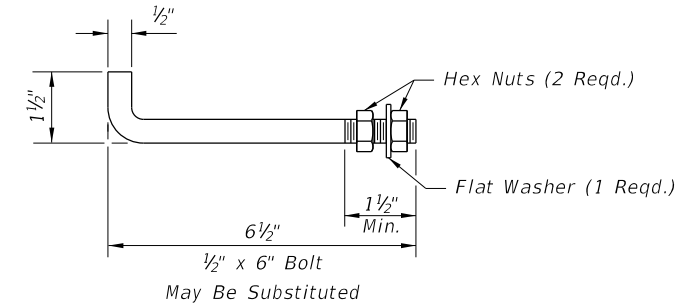

Anchors required for CMP only.
Anchor, washer and nuts to be galvanized steel.
Bend anchor where required to center in concrete slab. Damaged surfaces to be repaired after bending. Anchors are to be spaced a distance equal to four (4) corrugations. Place the anchors in the outside crest of corrugation.
Flat washers to be placed on inside wall of pipe.
Holes in the mitered end pipe are to be drilled or punched; burning not permitted.

ANCHOR DETAIL

SPECIAL DETAILS AND NOTES

10/30/2018 8:48:05 AM

LAST REVISION 11/01/17	DESCRIPTION:	 FY 2019-20 STANDARD PLANS	CROSS DRAIN MITERED END SECTION	INDEX 430-021	SHEET 6 of 6
---------------------------	--------------	----------------------------------------------------------------------------------------------------------------------	---------------------------------	------------------	-----------------

DIMENSIONS & QUANTITIES

D	X	A	B	C	E	F	G	H ■	M				N	GRATE SIZES		CONCRETE (CY)				SODDING (SY)			
									Single Pipe	Double Pipe	Triple Pipe	Quad Pipe		Standard Weight Pipe	Extra Strong Pipe	Single Pipe	Double Pipe	Triple Pipe	Quad Pipe	Single Pipe	Double Pipe	Triple Pipe	Quad Pipe
15"	2'-7"	2.27'	4.09'	6.36'	4.03'	8'	1.22'	4.0'	4.63'	7.21'	9.79'	12.37'	1.19'			0.76	1.16	1.54	1.94	8	10	11	12
18"	2'-10"	2.36'	5.12'	7.48'	5.03'	9'	1.41'	4.0'	4.92'	7.75'	10.58'	13.42'	1.21'			0.85	1.28	1.71	2.17	9	10	12	13
24"	3'-5"	2.53'	7.18' △	9.71'	7.03' △	11'	1.73'	4.0'	5.50'	8.92'	12.33'	15.75'	1.25'			1.02	1.58	2.15	2.75	10	12	13	15
30"	4'-3"	2.70'	9.25'	11.95'	9.03'	13'	2.00'	4.0'	6.08'	10.33'	14.58'	18.83'	1.29'	2½"	3"	1.23	1.98	2.74	3.50	12	14	15	17
36"	5'-1"	2.87'	11.31' ◇	14.18'	11.03' ◇	15'	2.24'	4.0'	6.67'	11.75'	16.83'	21.92'	1.33'	2½"	3"	1.40	2.38	3.33	4.24	13	15	17	20
42"	6'-0"	3.05'	13.37'	16.42'	13.03'	17'	2.45'	4.0'	7.25'	13.25'	19.25'	25.25'	1.38'	2½"	3½"	1.60	2.83	4.04	5.26	14	17	19	22
48"	6'-9"	3.22'	15.43'	18.65'	15.03'	19'	2.65'	4.0'	7.83'	14.58'	21.33'	28.08'	1.42'	2½"	3½"	1.81	3.26	4.70	6.14	15	18	21	24
54"	7'-8"	3.39'	17.49'	20.88'	17.03'	21'	2.83'	4.0'	8.42'	16.08'	23.75'	31.42'	1.46'	3"	4"	2.03	3.78	5.54	7.28	17	20	23	27
60"	8'-6"	3.56'	19.55'	23.11'	19.03'	23'	3.00'	4.0'	9.00'	17.50'	26.00'	34.50'	1.50'	3"	4"	2.28	4.36	6.43	8.50	18	22	25	29

△ 6.42' △ 6.25' Dimensions permitted to allow use of 8' standard pipe lengths.
 ◇ 10.40' ◇ 10.10' Dimensions permitted to allow use of 12' standard pipe lengths.
 △ ◇ Concrete slab shall be deepened to form bridge across crown of pipe. See section below.

■ Values shown for estimating pipe quantities and are for information only.

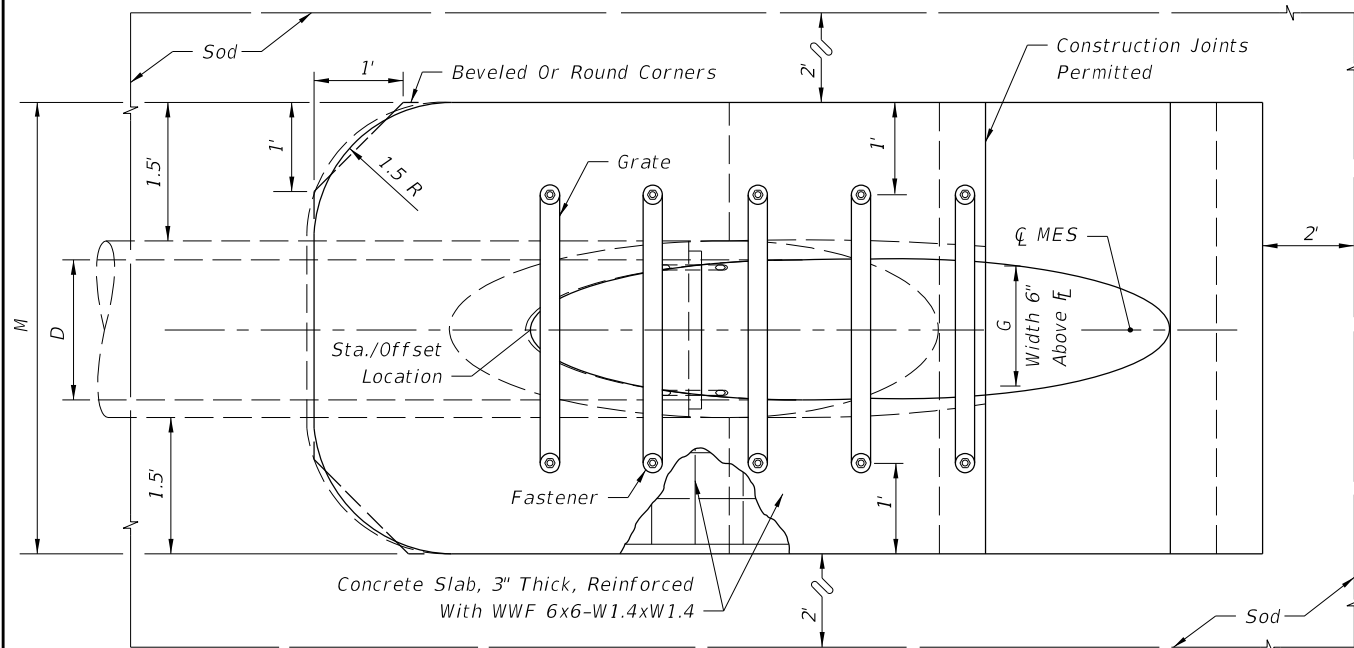

TOP VIEW-SINGLE PIPE

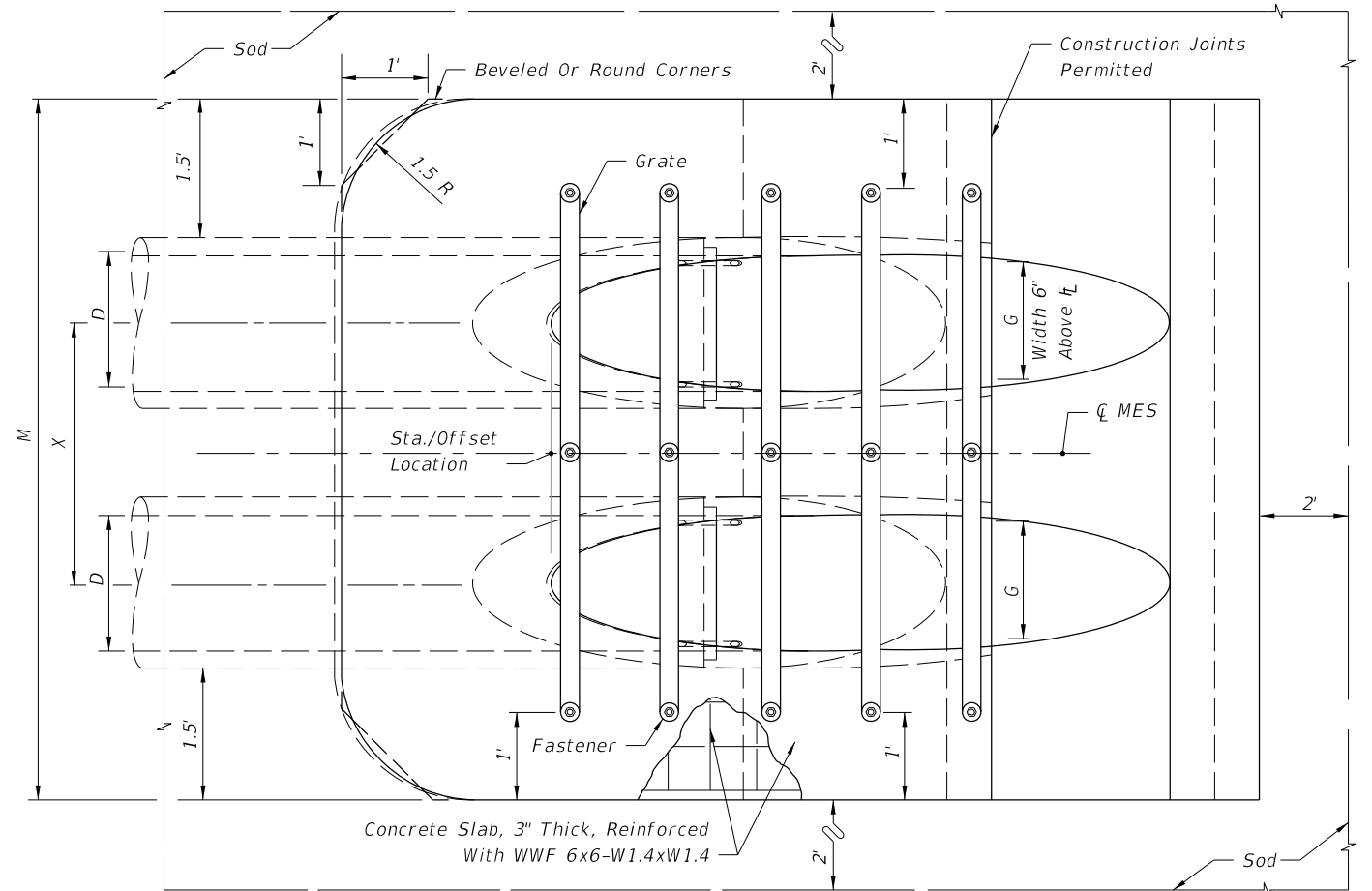

TOP VIEW-MULTIPLE PIPE

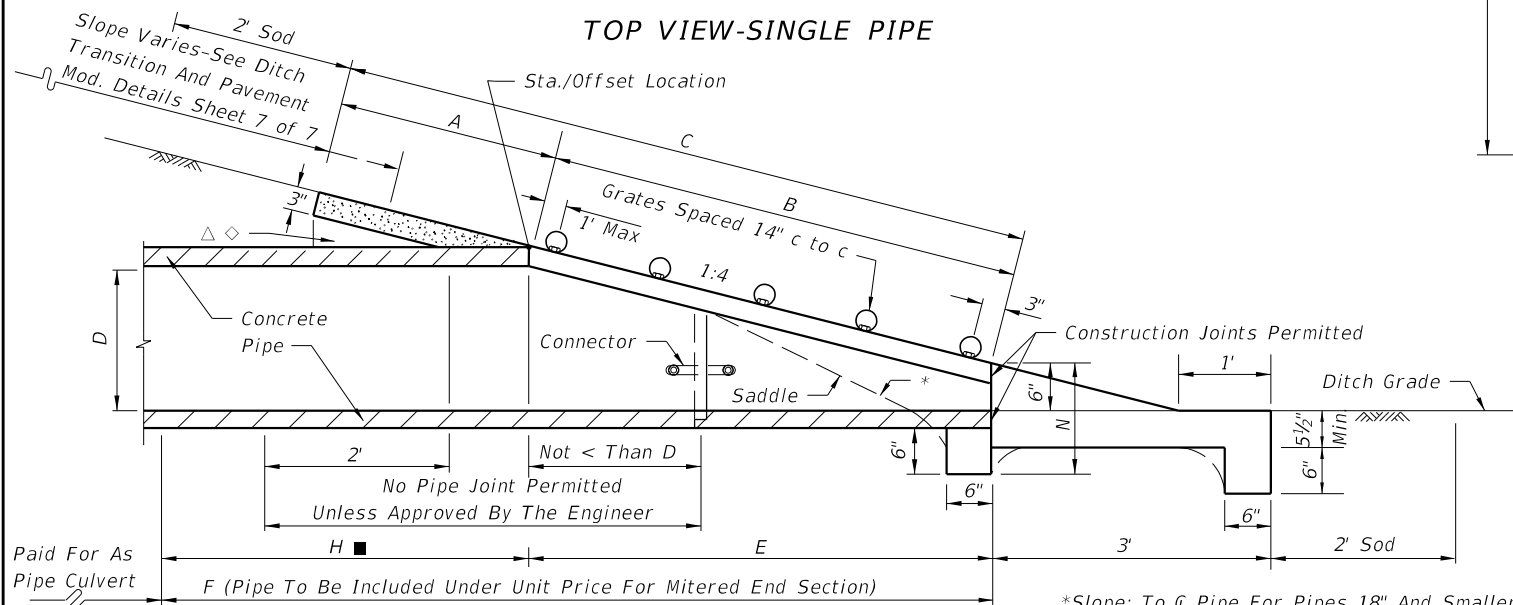

SECTION

Note: See Sheets 6 and 7 for details and general notes.

SINGLE AND MULTIPLE ROUND CONCRETE PIPE

10/30/2018 8:48:09 AM

LAST REVISION 11/01/17	DESCRIPTION:
---------------------------	--------------

**FY 2019-20
STANDARD PLANS**

SIDE DRAIN MITERED END SECTION

INDEX 430-022	SHEET 1 of 7
------------------	-----------------

DIMENSIONS & QUANTITIES

1974 AASHTO		X	A	B	C	E	F	G	H ■	M				N	GRATE SIZES		CONCRETE (CY)				SODDING (SY)			
Span	Rise									Single Pipe	Double Pipe	Triple Pipe	Quad. Pipe		Standard Weight Pipe	Extra Strong Pipe	Single Pipe	Double Pipe	Triple Pipe	Quad. Pipe	Single Pipe	Double Pipe	Triple Pipe	Quad. Pipe
17"	13"	2'-6"	2.5'	2.41'	4.91'	2.33'	7'	1.39'	4.7'	4.50'	7.00'	9.50'	12.00'	1.04'			0.62	0.95	1.27	1.60	8	9	10	11
21"	15"	2'-10"	2.5'	3.09'	5.59'	3.00'	8'	1.76'	5.0'	4.83'	7.67'	10.50'	13.33'	1.04'			0.69	1.06	1.44	1.77	8	9	11	12
28"	20"	3'-5"	2.5'	4.81'	7.31'	4.67'	9'	2.22'	4.3'	5.42'	8.83'	12.25'	15.67'	1.04'			0.81	1.26	1.73	2.19	9	11	12	14
35"	24"	4'-0"	2.5'	6.18'	8.68'	6.00'	11'	2.55'	5.0'	6.00'	10.00'	14.00'	18.00'	1.04'	2½"	3"	0.94	1.51	2.09	2.66	10	12	14	15
42"	29"	4'-9"	2.5'	7.90'	10.40'	7.67'	12'	2.97'	4.3'	6.58'	11.33'	16.08'	20.83'	1.04'	2½"	3½"	1.06	1.76	2.46	3.16	11	13	15	17
49"	33"	5'-6"	2.5'	9.28'	11.78'	9.00'	14'	3.34'	5.0'	7.17'	12.67'	18.17'	23.67'	1.04'	2½"	3½"	1.19	2.02	2.84	3.68	12	14	17	19
57"	38"	6'-4"	2.5'	11.00'	13.50'	10.67'	16'	3.65'	5.3'	7.83'	14.17'	20.50'	26.83'	1.04'	3"	4"	1.35	2.35	3.35	4.36	13	16	19	22
64"	43"	7'-1"	2.5'	12.71'	15.21'	12.33'	17'	3.89'	4.7'	8.42'	15.50'	22.58'	29.67'	1.04'	3"	4"	1.50	2.70	3.86	5.03	14	17	20	24
71"	47"	7'-10"	2.5'	14.09'	16.59'	13.67'	19'	4.14'	5.3'	9.00'	16.83'	24.67'	32.50'	1.04'	3"	4"	1.62	2.94	4.27	5.59	15	18	22	25

■ Values shown for estimating pipe quantities and are for information only.

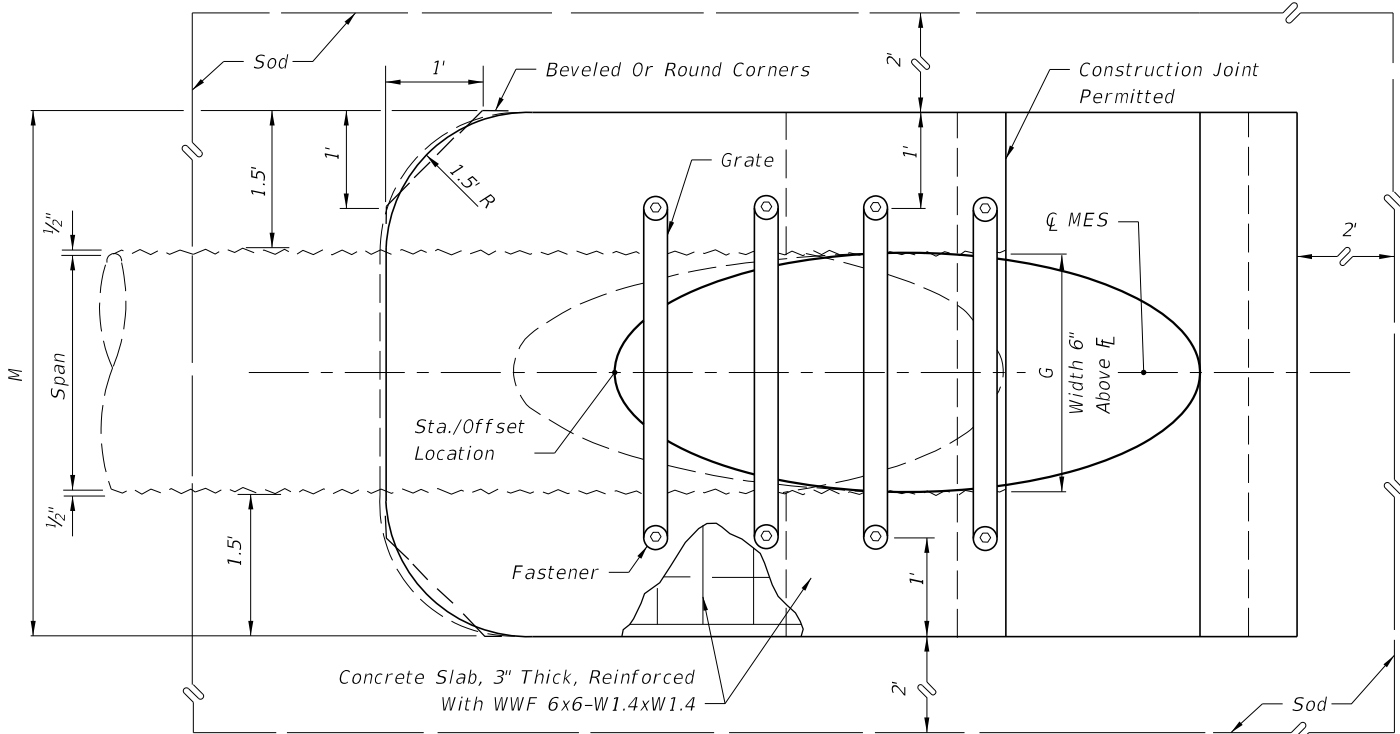

TOP VIEW-SINGLE PIPE

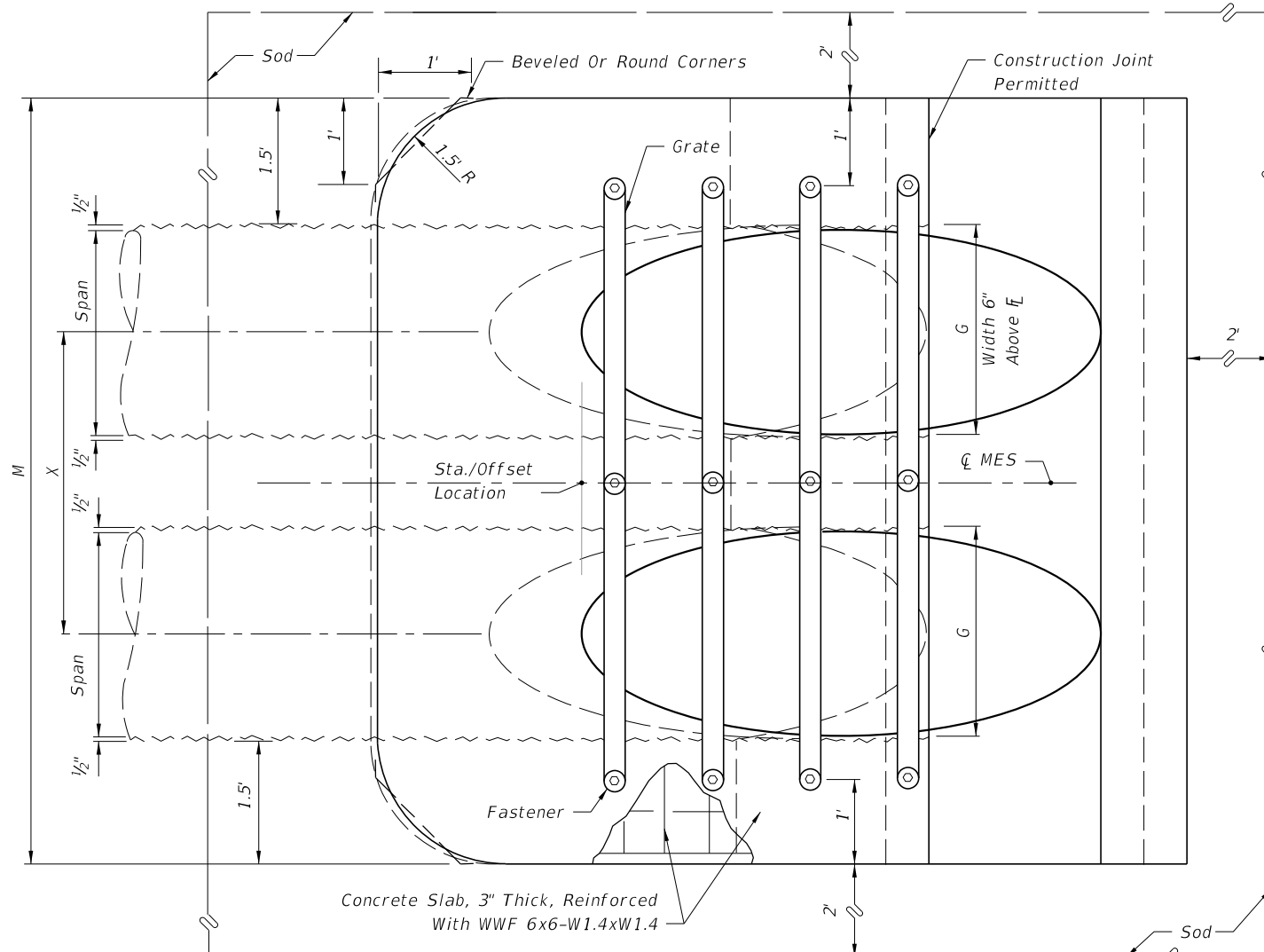

TOP VIEW-MULTIPLE PIPE

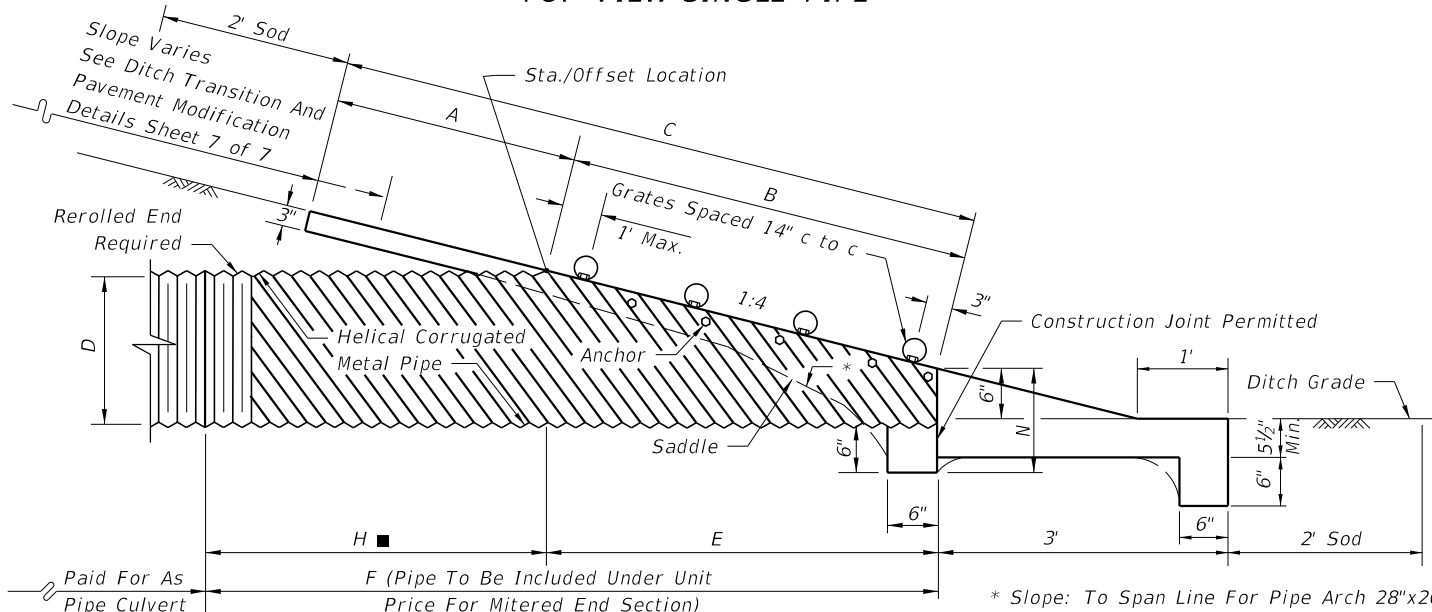

SECTION

NOTE: See Sheets 6 and 7 for details and general notes.

SINGLE AND MULTIPLE CORRUGATED METAL PIPE-ARCH

SIDE DRAIN MITERED END SECTION

10/30/2018 8:48:17 AM

LAST REVISION 11/01/17	REVISION	DESCRIPTION:
---------------------------	----------	--------------

DIMENSIONS & QUANTITIES

Rise R	Span S	X	A	B	C	E	F	G	H ■	M				N	GRATE SIZES		CONCRETE (CY)				SODDING (SY)			
										Single Pipe	Double Pipe	Triple Pipe	Quad. Pipe		Standard Weight Pipe	Extra Strong Pipe	Single Pipe	Double Pipe	Triple Pipe	Quad. Pipe	Single Pipe	Double Pipe	Triple Pipe	Quad. Pipe
12"	18"	2'-10"	2.36'	3.06'	5.42'	3.03'	5'	1.50'	2.0'	4.92'	7.75'	10.58'	13.42'	1.21'			0.68	1.04	1.41	1.77	8	9	11	12
14"	23"	3'-4"	2.44'	3.75'	6.19'	3.70'	6'	1.90'	2.3'	5.38'	8.71'	12.04'	15.38'	1.23'			0.76	1.19	1.63	2.05	9	10	12	13
19"	30"	4'-0"	2.62'	5.47'	8.09'	5.36'	8'	2.37'	2.6'	6.04'	10.04'	14.04'	18.04'	1.27'	2½"	3"	0.95	1.52	2.09	2.65	10	12	13	15
24"	38"	5'-0"	2.79'	7.18'	9.97'	7.03'	10'	2.85'	3.0'	6.79'	11.79'	16.79'	21.79'	1.31'	2½"	3"	1.18	1.95	2.74	3.53	11	13	15	18
29"	45"	5'-11"	3.05'	8.90'	11.95'	8.70'	12'	3.19'	3.3'	7.50'	13.42'	19.33'	25.25'	1.38'	2½"	3½"	1.41	2.42	3.44	4.45	12	15	18	20
34"	53"	7'-0"	3.22'	10.62'	13.84'	10.36'	13'	3.57'	3.6'	8.25'	15.25'	22.25'	29.25'	1.42'	3"	3½"	1.63	2.92	4.22	5.52	13	17	20	23
38"	60"	7'-10"	3.39'	11.99'	15.38'	11.70'	15'	3.95'	3.3'	8.92'	16.75'	24.58'	32.42'	1.46'	3"	4"	1.83	3.36	4.89	6.41	14	18	21	25
43"	68"	8'-11"	3.56'	13.71'	17.27'	13.36'	17'	4.28'	3.6'	9.67'	18.58'	27.50'	36.42'	1.50'	3"	4"	2.09	3.95	5.80	7.65	16	20	23	27
48"	76"	9'-11"	3.73'	15.43'	19.16'	15.03'	19'	4.59'	4.0'	10.42'	20.33'	30.25'	40.17'	1.54'	3"	HSS 5"x¾"	2.37	4.54	6.73	8.92	17	21	26	30
53"	83"	10'-8"	3.91'	17.15'	21.06'	16.70'	20'	4.77'	3.3'	11.08'	21.75'	32.42'	43.08'	1.58'	3"	HSS 5"x¾"	2.61	5.09	7.56	10.03	18	23	27	32
58"	91"	11'-8"	4.08'	18.87'	22.95'	18.36'	22'	5.01'	3.6'	11.83'	23.50'	35.17'	46.83'	1.63'	3½"	HSS 5"x¾"	2.91	5.77	8.64	11.50	19	24	29	35

■ Values shown for estimating pipe quantities and are for information only.

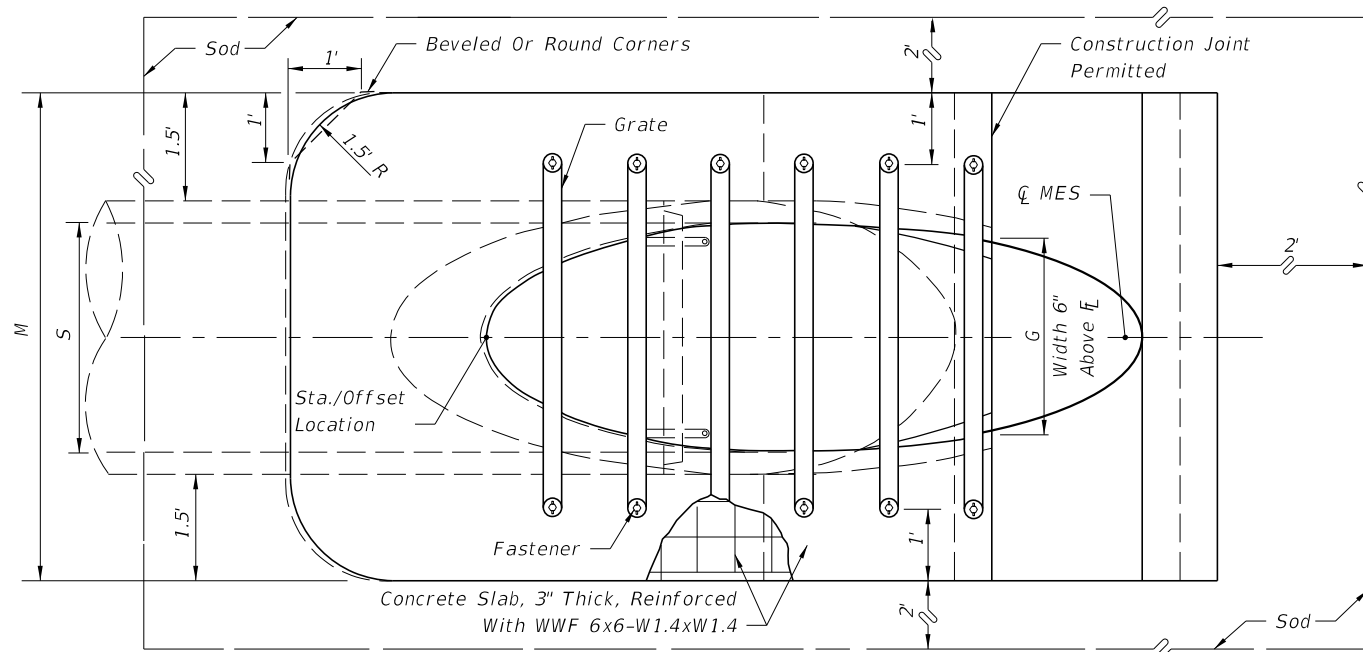

TOP VIEW-SINGLE PIPE

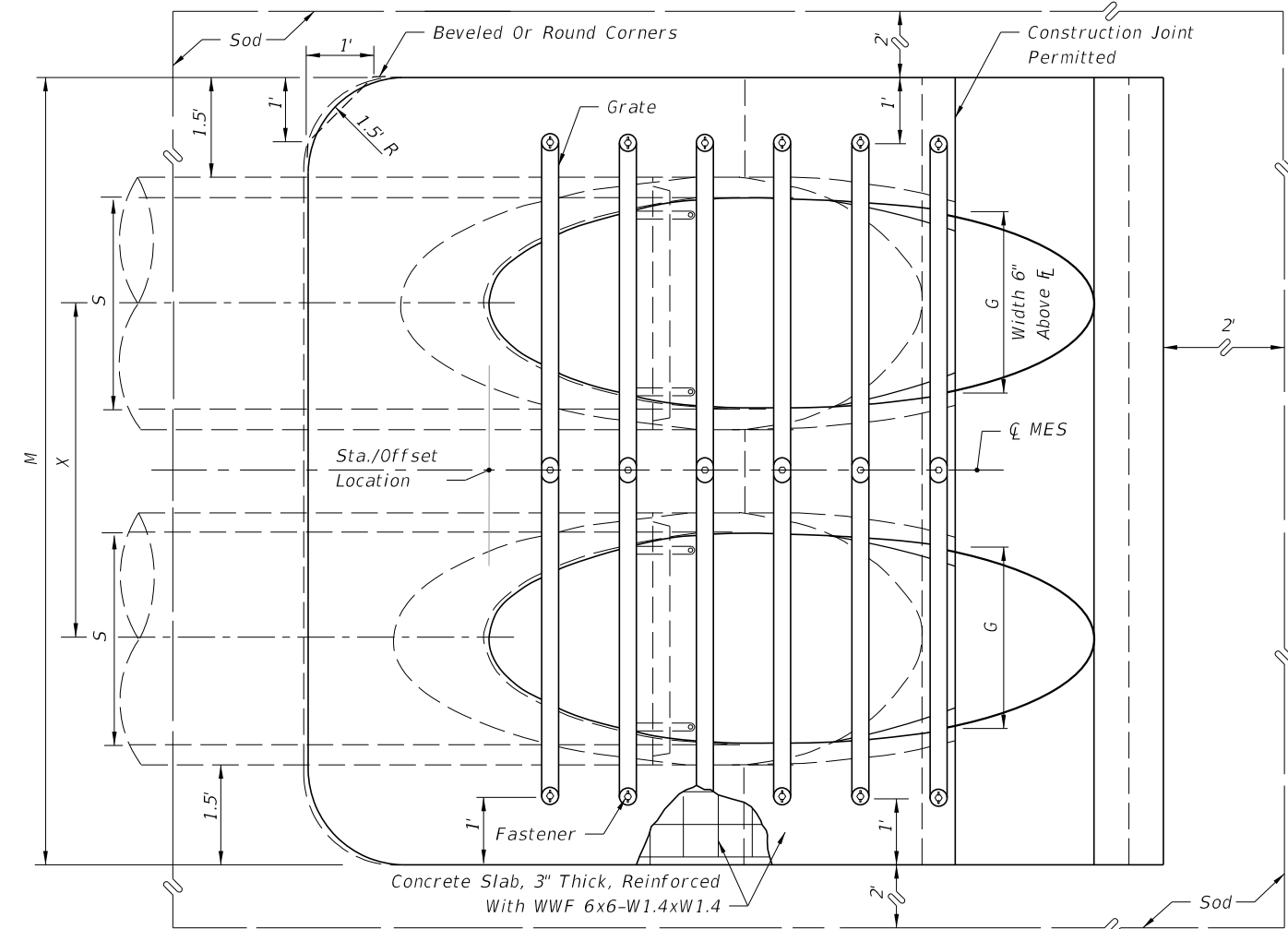

TOP VIEW-MULTIPLE PIPE

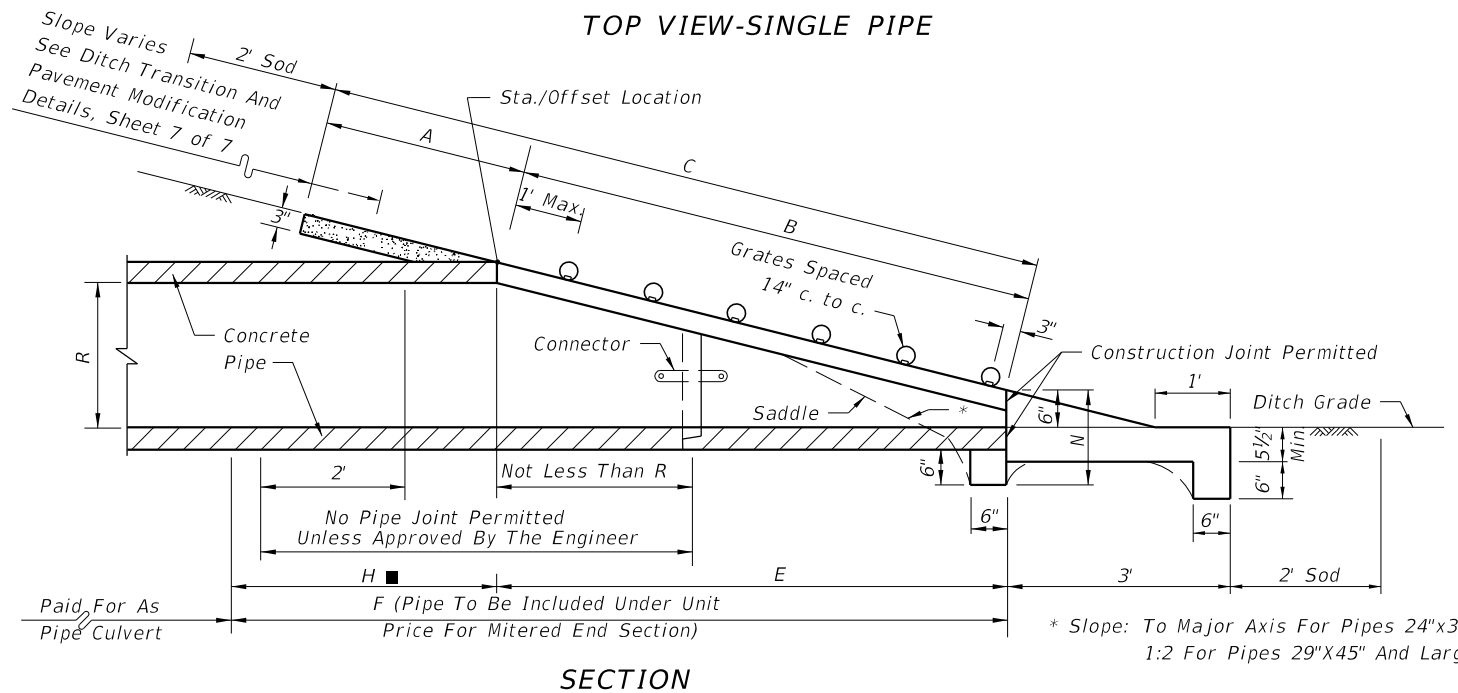

SECTION

* Slope: To Major Axis For Pipes 24"x38" And Smaller.
1:2 For Pipes 29"x45" And Larger.

NOTE: See Sheets 6 and 7 for details and general notes.

SINGLE AND MULTIPLE ELLIPTICAL CONCRETE PIPE

10/30/2018 8:48:20 AM

LAST REVISION 11/01/17	DESCRIPTION:	 FY 2019-20 STANDARD PLANS	SIDE DRAIN MITERED END SECTION	INDEX 430-022	SHEET 4 of 7
---------------------------	--------------	----------------------------------	--------------------------------	------------------	-----------------

Drain Size	s	n	L	La
------------	---	---	---	----

CONCRETE PIPE (ROUND)

15"	3	4	4'-0"	4'-11"
18"	4	5	5'-2"	6'-1"
24"	6	7	7'-6"	8'-5"
30"	7	8	8'-8"	9'-7"
36"	9	10	11'-0"	11'-11"
42"	11	12	13'-4"	14'-3"
48"	13	14	15'-8"	16'-7"
54"	14	15	16'-10"	17'-9"
60"	16	17	19'-2"	20'-1"

CORRUGATED METAL PIPE (ROUND)

15"	2	3	2'-10"	3'-9"
18"	3	4	4'-0"	4'-11"
24"	5	6	6'-4"	7'-3"
30"	7	8	8'-8"	9'-7"
36"	8	9	9'-10"	10'-9"
42"	10	11	12'-2"	13'-1"
48"	12	13	14'-6"	15'-5"
54"	14	15	16'-10"	17'-9"
60"	15	16	18'-0"	18'-11"

Drain Size	s	n	L	La
------------	---	---	---	----

ELLIPTICAL CONCRETE PIPE

12"x18"	2	3	2'-10"	3'-9"
14"x23"	3	4	4'-0"	4'-11"
19"x30"	4	5	5'-2"	6'-1"
24"x38"	5	6	6'-4"	7'-3"
29"x45"	7	8	8'-8"	9'-7"
34"x53"	8	9	9'-10"	10'-9"
38"x60"	10	11	12'-2"	13'-1"
43"x68"	11	12	13'-4"	14'-3"
48"x76"	13	14	15'-8"	16'-7"
53"x83"	14	15	16'-10"	17'-9"
58"x91"	15	16	18'-0"	18'-11"

CORRUGATED METAL PIPE (ARCH)

17"x13"	1	2	1'-8"	2'-7"
21"x15"	2	3	2'-10"	3'-9"
28"x20"	4	5	5'-2"	6'-1"
35"x24"	5	6	6'-4"	7'-3"
42"x29"	6	7	7'-6"	8'-5"
49"x33"	7	8	8'-8"	9'-7"
57"x38"	9	10	11'-0"	11'-11"
64"x43"	10	11	12'-2"	13'-1"
71"x47"	12	13	14'-6"	15'-5"

Note: 5/8" x 3" bolts are standard for all grate fasteners, except when the contractor elects to use the slotted upper holes for the intermediate fasteners on multiple drain pipes, which will require the following bolt lengths:

Grate Size (Std. & X-Stg.)	Bolt Length
2 1/2"	5 1/2"
3"	6"
3 1/2"	6 1/2"
4"	7"

** To be used only when grates are called for in the plans.

*** 1974 AASHTO Pipe Arch Sizes.

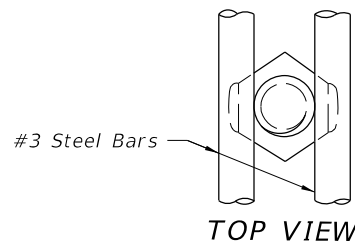

5/8" Galvanized Bolt Hex Head Bolt Shown; Either Hex Head Or Square Head Bolt May Be Used. Only Hex Nut To Be Used.

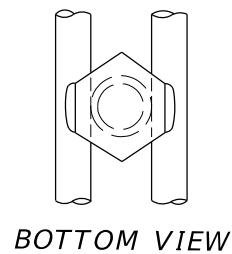
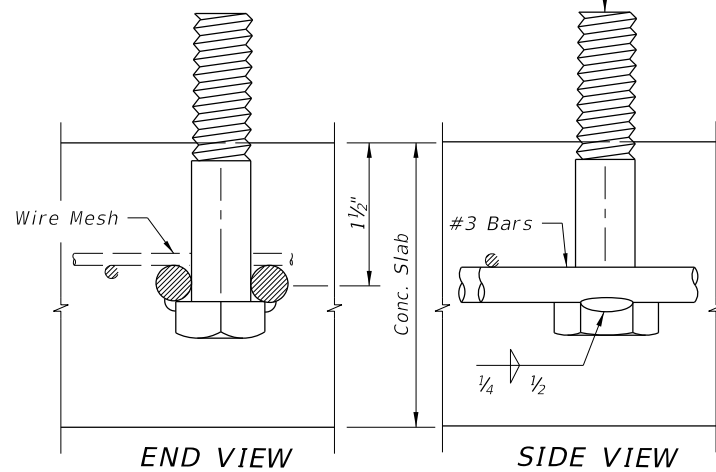

The specified weld shall be made when the fabricated unit is subject to hazardous hauls and repeated handling. Tack welds are permitted for local or job site fabrication. Galvanizing over welded surface not required.

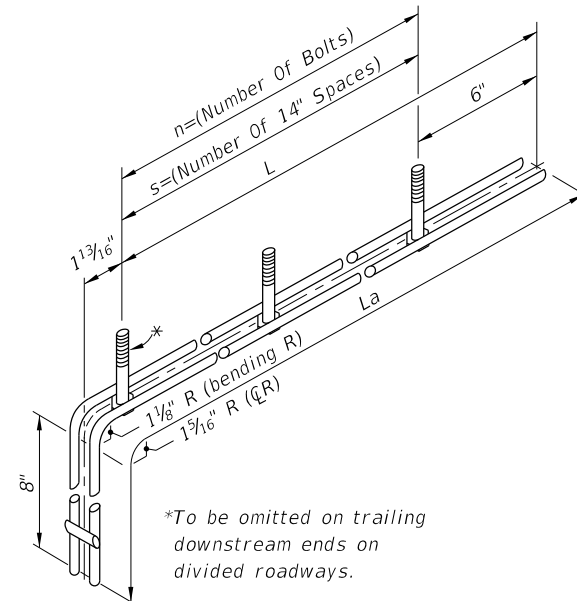
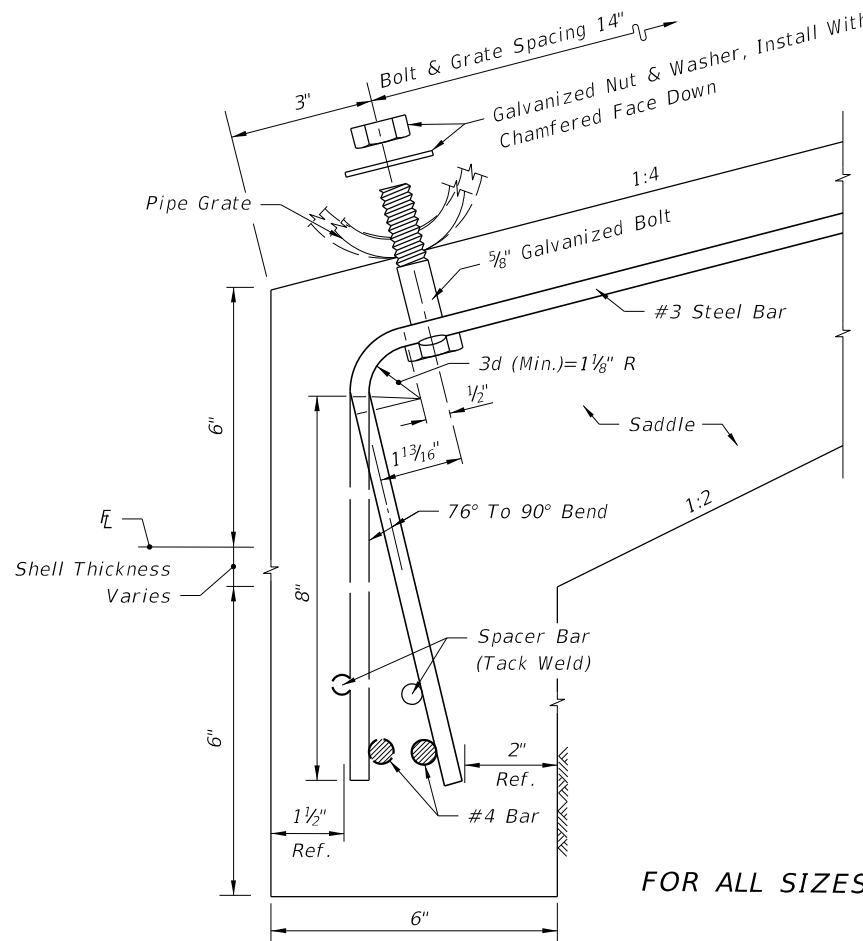

*To be omitted on trailing downstream ends on divided roadways.

FOR ALL SIZES OF SINGLE AND MULTIPLE DRAIN PIPE FASTENER UNIT

DETAILS FOR CONCRETE & CORRUGATED METAL PIPE

10/30/2018 8:48:23 AM

LAST REVISION 11/01/17

DESCRIPTION:



FY 2019-20 STANDARD PLANS

SIDE DRAIN MITERED END SECTION

INDEX 430-022

SHEET 5 of 7

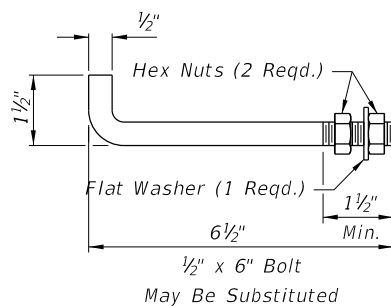

Notes:
 Anchors required for CMP only.
 Anchor, washer and nuts to be galvanized steel.
 Bend anchor where required to center in concrete slab.
 Damaged surfaces to be repaired after bending.
 Anchors are to be spaced a distance equal to four (4) corrugations.
 Place the anchors in the outside crest of corrugation.
 Flat washer to be placed on inside wall of pipe.
 Holes in the mitered end pipe are to be drilled or punched; burning not permitted.

ANCHOR DETAIL

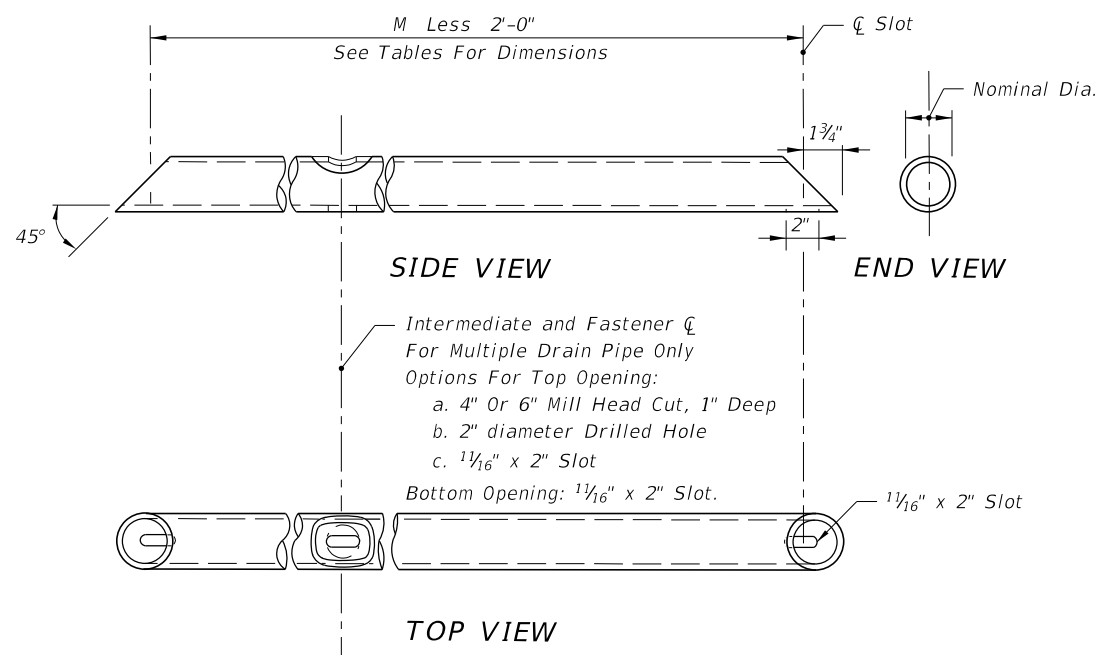

**FOR SINGLE & MULTIPLE DRAIN PIPE
 GRATE DETAIL**

See General Notes, Sheet 7.

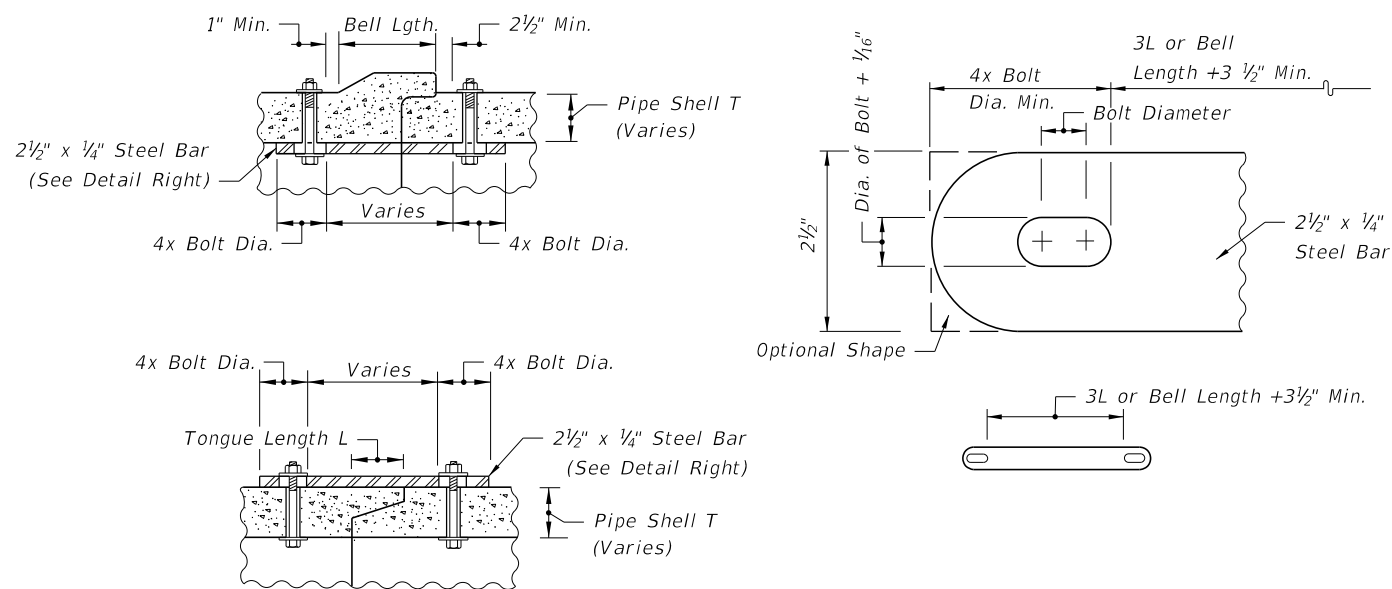

All bars, bolts, nuts and washers are to be galvanized steel.
 Bolt diameters shall be 3/8" for 15" to 36" pipe and 5/8" for 42" to 60" pipe.
 Two connectors required per joint, located 60° right and left of bottom center of pipe.
 Bolt holes in pipe shell are to be drilled.

CONCRETE PIPE CONNECTOR DETAIL

DETAILS FOR CONCRETE & CORRUGATED METAL PIPE

10/30/2018 8:48:29 AM

LAST REVISION 11/01/17	DESCRIPTION:		FY 2019-20 STANDARD PLANS	SIDE DRAIN MITERED END SECTION	INDEX 430-022	SHEET 6 of 7
---------------------------	--------------	--	------------------------------	--------------------------------	------------------	-----------------

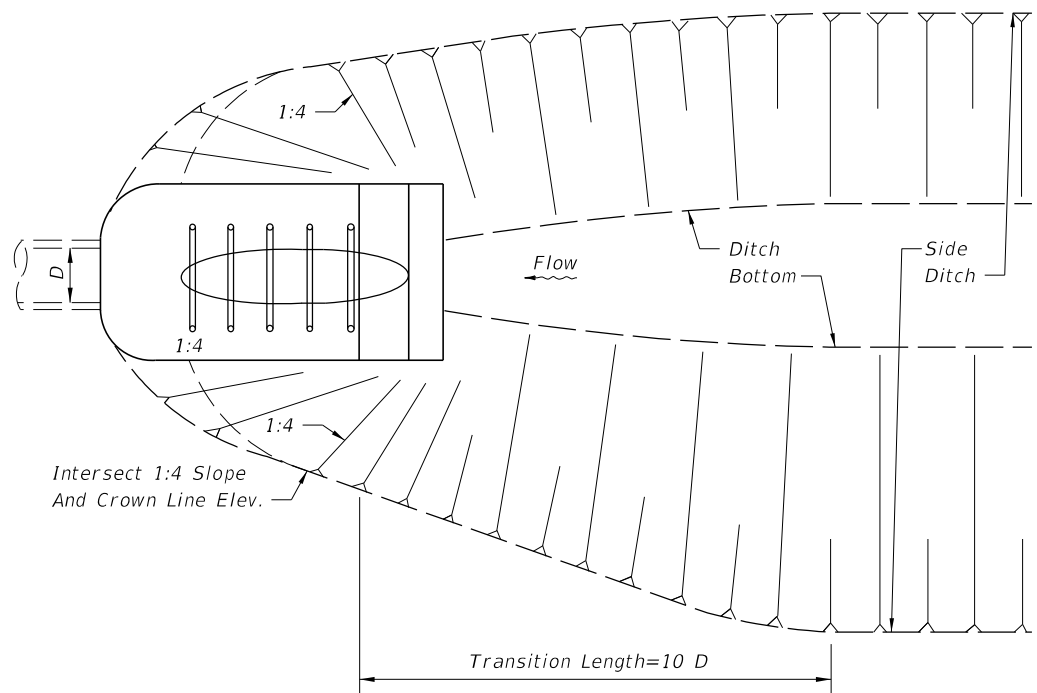

**PLAN
DITCH TRANSITION**

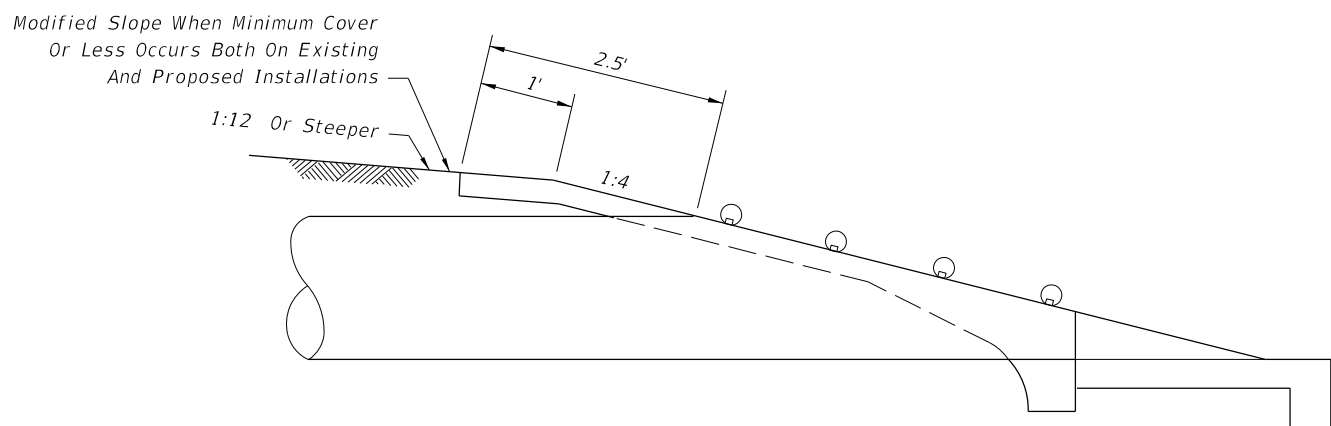

PERMISSIBLE PAVEMENT MODIFICATION

GENERAL NOTES

1. Unless otherwise designated in the plans, concrete pipe mitered end sections may be used with any type of side drain pipe; corrugated steel pipe mitered end sections may be used with any type of side drain pipe except aluminum pipe; and, corrugated aluminum mitered end sections may be used with any type of side drain pipe except steel pipe. When bituminous coated metal pipe is specified for side drain pipe, construct the mitered end sections with like pipe or concrete pipe. When the mitered end section pipe is dissimilar to the side drain pipe, construct a concrete jacket in accordance with Index 430-001.
2. Use either corrugated metal or concrete mitered end sections for corrugated polyethylene pipe (HDPE), polyvinyl-chloride pipe (PVC) and polypropylene pipe (PPP). When used in conjunction with corrugated mitered end sections, make connection using either a formed metal band specifically designated to join HDPE or PVC pipe, with metal pipe or other coupler approved by the State Drainage Engineer. When used in conjunction with a concrete mitered end sections, concrete jacket constructed in accordance with Index 430-001.
3. Select lengths of concrete pipe that avoid excessive connections in the assembly of the mitered end section.
4. Repair corrugated metal pipe galvanizing that is damaged during beveling and perforating.
5. Prior to placing concrete slab apply a bituminous coating to any portion of corrugated metal pipe in direct contact with concrete. Extend the coating 12" beyond the concrete slab.
6. When existing multiple side drain pipes are spaced other than the dimensions shown in this Index, have nonparallel axes, or non-uniform sections, either construct the mitered end sections separately as single pipe or collectively as multiple pipe end sections as directed by the Engineer.
7. Class NS concrete cast-in-place reinforced slabs are required for all sizes of side drain pipes.
8. Install grates on all round pipes 30" or greater, pipe-arches 35"x24" or greater, and elliptical pipe 19"x30" or greater, unless excluded in the Plans. Install grates on smaller size pipes only when called for in the Plans. Omit the lower grate on the downstream end of mitered end sections along divided highways.
9. Use Schedule 80 pipe for the lower grate on all traffic approach ends and Schedule 40 pipe for all remaining grates. Fabricate the grates from ASTM A53, Grade B, black steel pipe and hot dip galvanize after fabrication in accordance with ASTM A123 for all corrosive environments.

DESIGN NOTES

1. Do not use grates until the debris transport potential has been evaluated by the drainage engineer and appropriate adjustments made. Ditch grades in excess of 3% or pipe with less than 1.5' of cover and grades in excess of 1% will require such an evaluation (General Note 10).
2. The design engineer must determine and designate in the plans which alternate types of mitered end section will not be permitted. Restrict use based on corrosive or structural requirements.
3. Contact the District Drainage Engineer for possible alternate treatment of side drain mitered end sections where a minimum spacing of 30' will not result between the toe points of the mitered end sections.
4. Provide ditch transitions on all grades in excess of 3%.

NOTES & INFORMATION

10/30/2018 8:48:32 AM

LAST REVISION 11/01/17	REVISION	DESCRIPTION:	 FY 2019-20 STANDARD PLANS	SIDE DRAIN MITERED END SECTION	INDEX 430-022	SHEET 7 of 7
---------------------------	----------	--------------	-------------------------------------------------------------------------------------------------------------------------------	---------------------------------------	-------------------------	------------------------

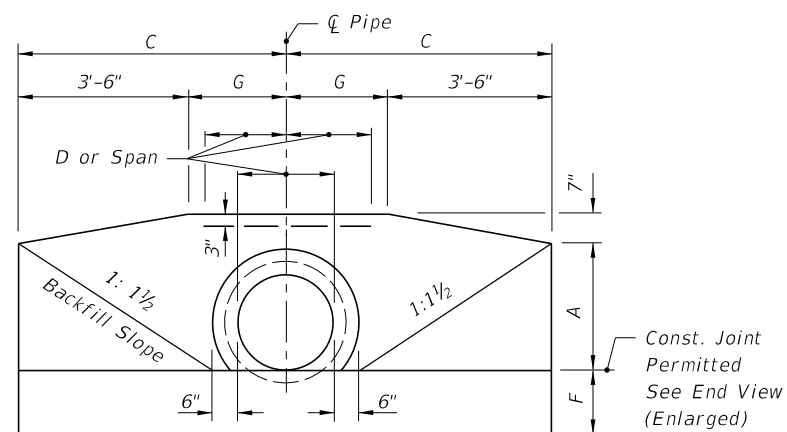

FRONT VIEW

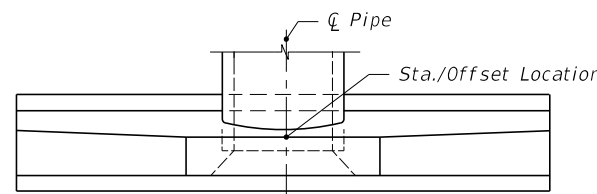

TOP VIEW

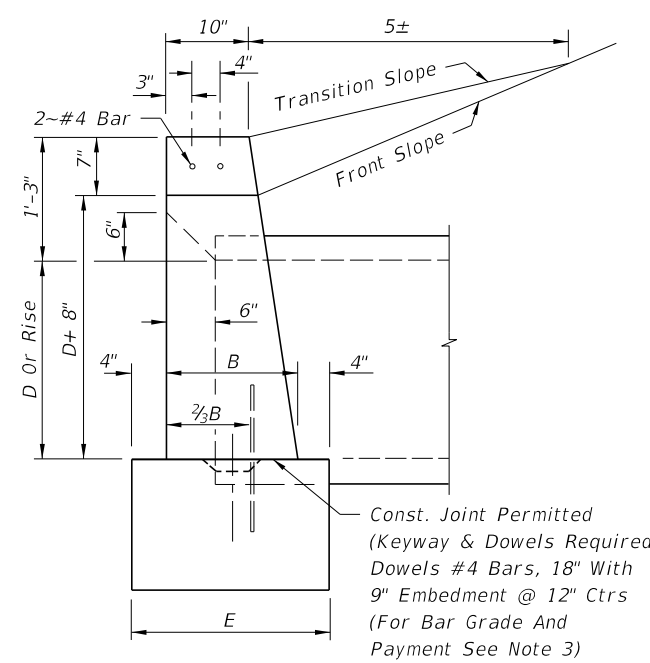

END VIEW (ENLARGED)

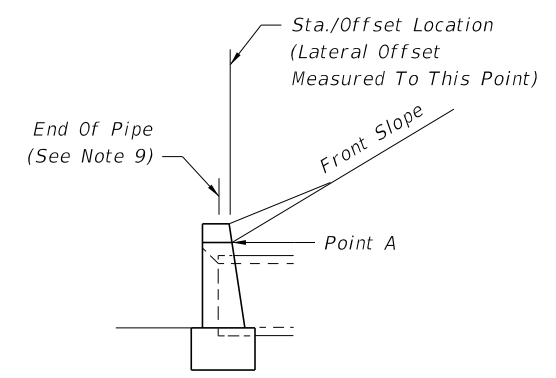

END VIEW

1. Position is set by the intersection of the front slope and Point A where this intersection falls outside the clear zone.
2. Where the front slope and Point A intersects inside the clear zone, the endwall is positioned so the Station/Offset Location is at the clear zone limit. The front slope is transitioned to the endwall as shown in Index 430-001.

STANDARD LOCATION CONTROL

GENERAL NOTES

1. Endwall dimensions, locations and positions are for round and elliptical concrete pipe and for round and pipe-arch corrugated metal pipe. Round concrete pipe shown.
2. Front slope and ditch transitions shall be in accordance with Index 430-001.
3. Endwalls may be cast in place or precast concrete. Reinforcing steel shall be Grades 40 or 60. Additional reinforcement necessary for handling precast units shall be determined by the Contractor or the supplier. Cost of reinforcement shall be included in the contract unit price for Concrete, (Endwalls).
4. All exposed corners and edges of concrete are to be chamfered 3/4".
5. Concrete shall be Class I, except ASTM C478 (4000 psi) concrete may be substituted for precast items manufactured in plants meeting the requirements of Section 449 of the Specifications.
6. On outfall ditches with side slopes flatter than 1:1 1/2 provide 20' transitions from the endwall to the flatter side slopes, right of way permitting.
7. For sodding around endwalls see Index 524-001.
8. Payment for concrete quantities for endwalls skewed to the pipe shall be made on the following basis:

Endwall Skew to Pipe	Use Tabulated Value
0° to 5°	0°
6°	15°
16°	30°
31° or over	45°
9. Pipe length plan quantities shall be based on the pipe end locations shown in the standard location control end view, or lengths based on special endwall locations called for in the plans.
10. Payment for pipe in pipe culverts shall be based on plan quantities, adjusted for endwall locations subsequently established by the Engineer.
11. Endwalls to be paid for under the contract unit price for Class I Concrete (Endwalls), CY.

ENDWALL DIMENSIONS (EXCLUSIVE OF MULTIPLE PIPE SPACING)

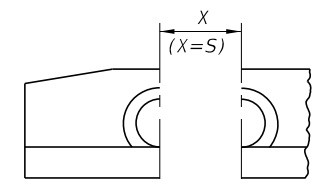

FRONT VIEW

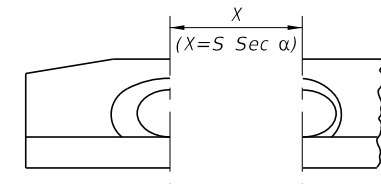

FRONT VIEW

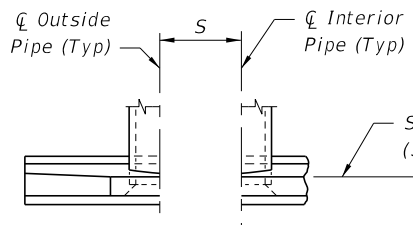

TOP VIEW

NORMAL PIPE

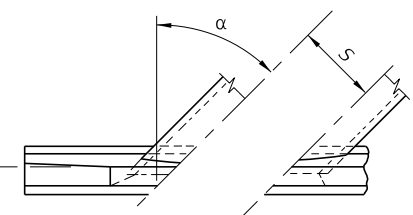

TOP VIEW

SKewed PIPE

LEGEND

- α Pipe Skew
- S Center To Center Pipe Spacing
- X Centerline To Centerline Dimension At Face Of Headwall

**PIPE AND SPACING FOR MULTIPLE PIPE
ENDWALL POSITIONS FOR SINGLE AND MULTIPLE**

10/30/2018 8:48:35 AM

LAST REVISION 11/01/17	REVISION	DESCRIPTION:	 FY 2019-20 STANDARD PLANS	STRAIGHT CONCRETE ENDWALLS SINGLE AND MULTIPLE PIPE	INDEX 430-030	SHEET 1 of 2
---------------------------	----------	--------------	----------------------------------------------------------------------------------------------------------------------	----------------------------------------------------------------	-------------------------	------------------------

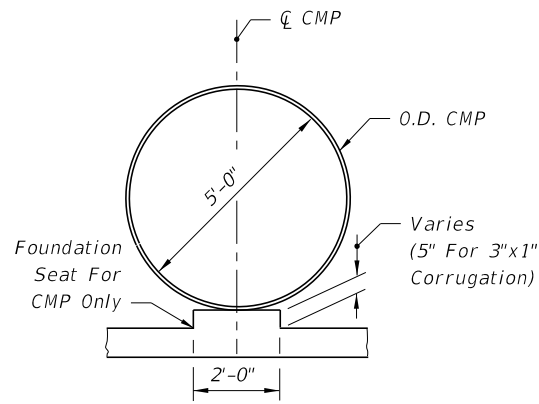

SECTION BB

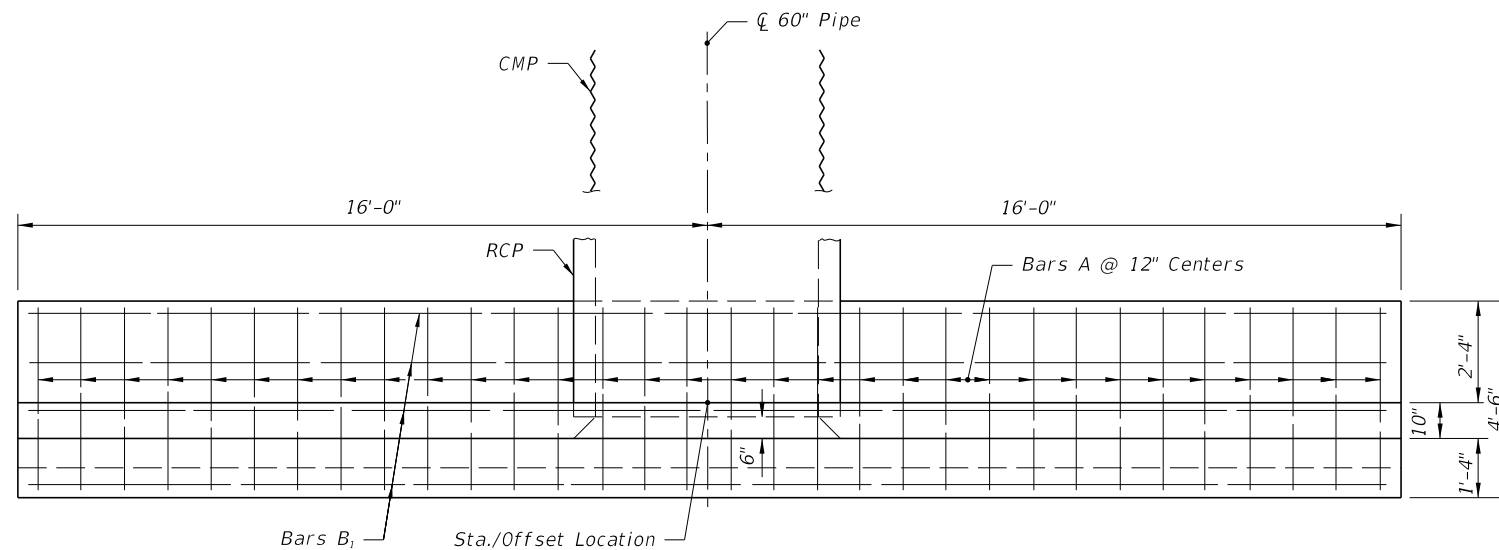

PLAN
(Showing Bar In Footing)

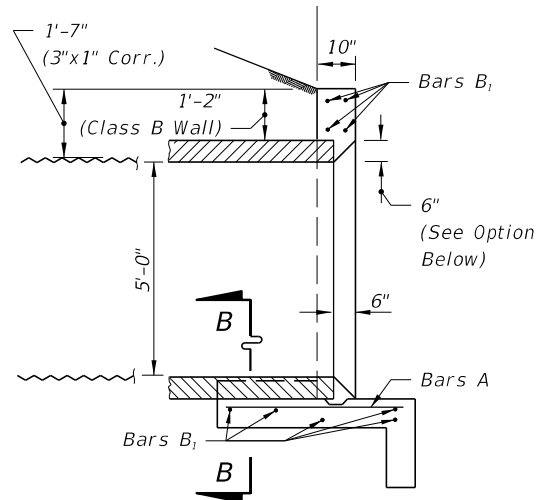

SECTION AA

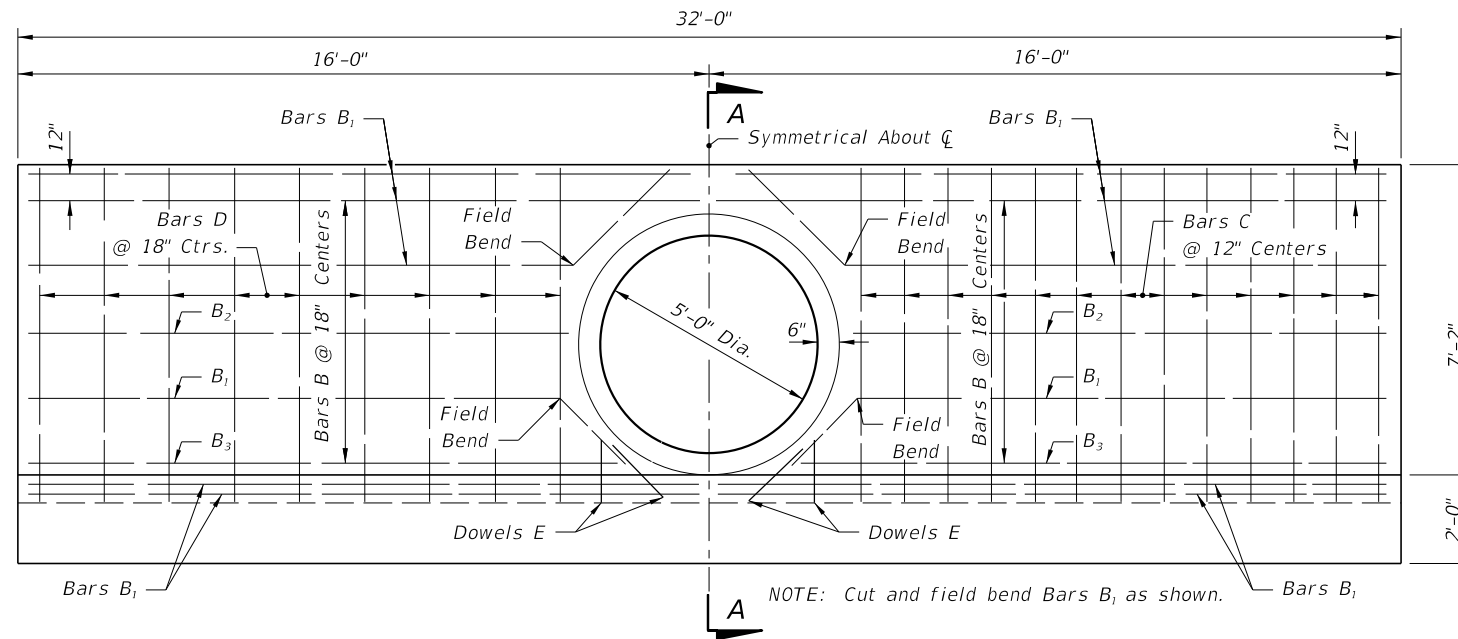

HALF ELEVATION
(Showing Bars In Front Face Of Wall)

HALF ELEVATION
(Showing Bars In Back Face Of Wall)

BILL OF REINFORCING STEEL					
MARK	SIZE	NO. REQD.	LENGTH	LOCATION	BENDING
A	#4	32	4'-2"	Footing	Straight
B ₁	#4	13	31'-8"	Footing & Wall	Straight
B ₂	#4	4	12'-4"	Wall	Straight
B ₃	#4	4	13'-9"	Wall	Straight
C	#4	26	9'-4"	Wall	Bend
D	#4	18	7'-6"	Wall	Straight
E	#4	8	1'-8"	Footing & Wall	Straight

BENDING DIAGRAM

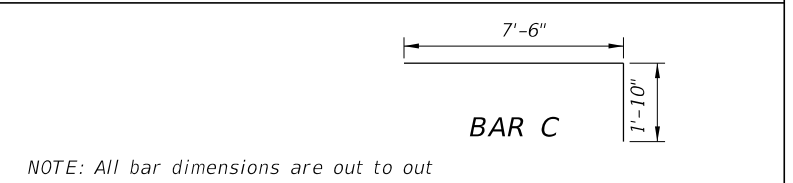

ESTIMATED QUANTITIES

ITEM	UNIT	RCP	CMP
Class II Concrete	Cu. Yd.	11.3	11.4
Reinforcing Steel	Lb.	695	695

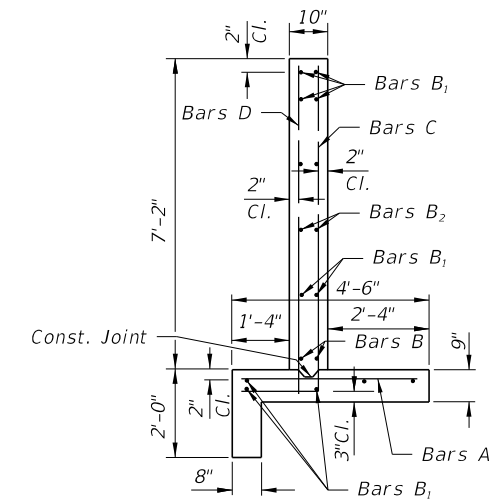

TYPICAL SECTION
THRU ENDWALL

GENERAL NOTES

1. Straight concrete endwalls are intended for use outside the clear zone.
2. Endwalls may be cast-in-place or precast construction. Cast-in-place endwalls shall conform to the details on this Index. Precast construction which adheres to this Index, including any additional reinforcement required for handling which shall be determined by the Contractor or supplier, does not require additional approvals. Deviations from this Index, for precast units, shall require the approval of the State Drainage Engineer prior to construction. For precast construction, see Index 425-001 for opening and grouting details.
3. Reinforcing steel shall be either Grade 40 or 60.
4. Concrete shall be Class II, except ASTM C478 (4000 psi) concrete may be substituted for precast items manufactured in plants meeting the requirements of Section 449 of the Specifications.
5. Chamfer: All exposed edges and corners to be chamfered $\frac{3}{4}$ " unless otherwise shown.
6. That portion of corrugated metal pipe in direct contact with the concrete slab and extending 12" beyond shall have a continuous bituminous coating of .004" minimum thickness applied prior to placing of the concrete.
7. Sodding shall be in accordance with Index 524-001 and paid for under the contract unit price for Performance Turf, SY.
8. Basis of payment for either cast-in-place or precast construction shall be the estimated quantities tabulated on the Index. Concrete and reinforcing steel shall be paid for under the contract unit prices for Class II Concrete (Endwalls), CY and Reinforcing Steel (Roadway), LB.

OPTIONAL ENTRANCE
FOR CONCRETE PIPE

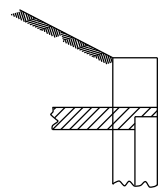

10/30/2018 8:48:45 AM

LAST REVISION 11/01/17	DESCRIPTION:
---------------------------	--------------



FY 2019-20
STANDARD PLANS

STRAIGHT CONCRETE ENDWALLS
SINGLE AND DOUBLE 60" PIPE

INDEX
430-031

SHEET
1 of 2

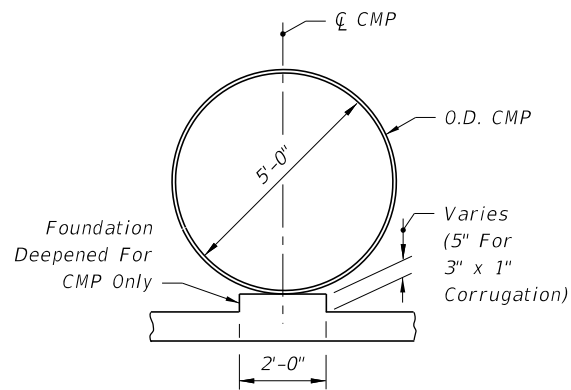

SECTION BB

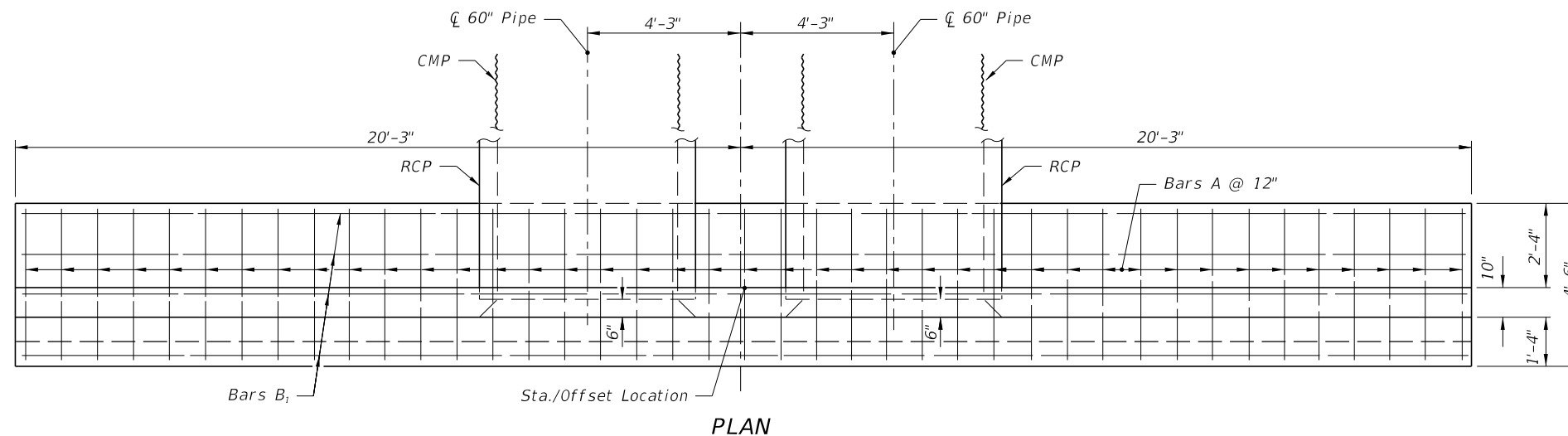

PLAN

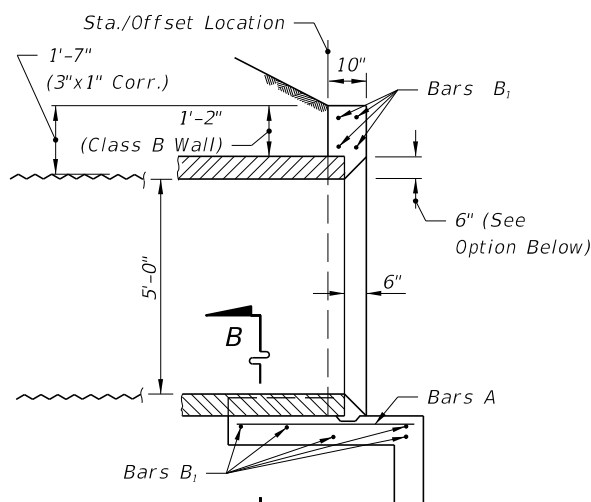

SECTION AA

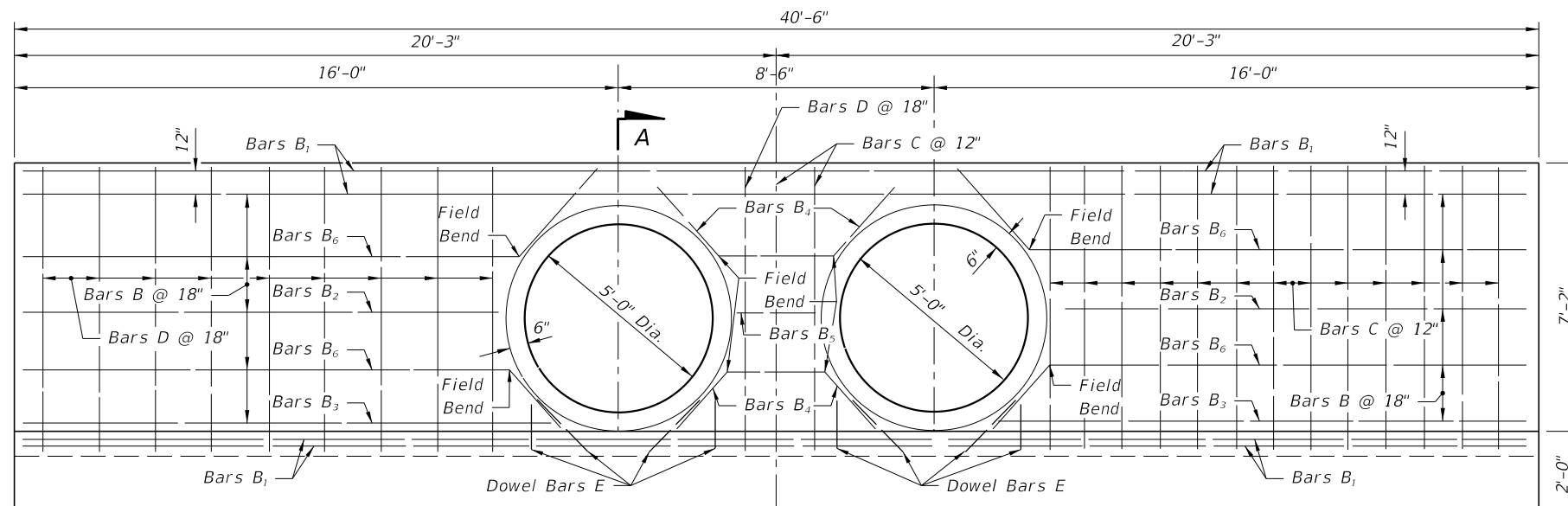

HALF ELEVATION
(Showing Bars In Front Face Of Wall)

HALF ELEVATION
(Showing Bars In Back Face Of Wall)

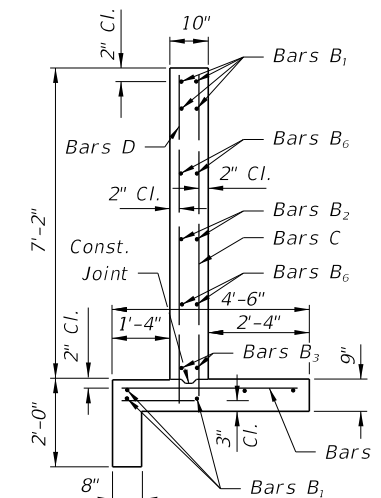

TYPICAL SECTION
THRU ENDWALL

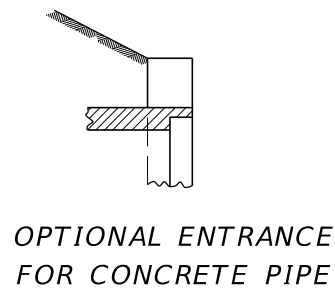

OPTIONAL ENTRANCE
FOR CONCRETE PIPE

BILL OF REINFORCING STEEL					
MARK	SIZE	NO. REQD.	LENGTH	LOCATION	BENDING
A	#4	41	4'-2"	Footing	Straight
B ₁	#4	9	40'-2"	Footing & Wall	Straight
B ₂	#4	4	12'-6"	Wall	Straight
B ₃	#4	4	13'-9"	Wall	Straight
B ₄	#4	4	6'-0"	Wall	Field Bend
B ₅	#4	2	2'-2"	Wall	Straight
B ₆	#4	8	15'-0"	Wall	Field Bend
C	#4	29	9'-4"	Footing & Wall	Bend
D	#4	20	7'-6"	Footing & Wall	Straight
E	#4	16	1'-8"	Footing & Wall	Straight

BENDING DIAGRAM

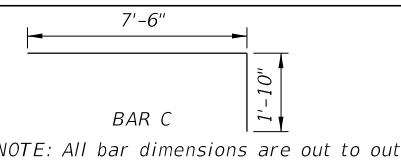

NOTE: All bar dimensions are out to out

ESTIMATED QUANTITIES

ITEM	UNIT	RCP	CMP
Class II Concrete	Cu. Yd.	13.7	13.8
Reinforcing Steel	Lb.	824	824

NOTE: See Sheet 1 of 2 For General Notes.

10/30/2018 8:48:48 AM

LAST REVISION
11/01/17

DESCRIPTION:



FY 2019-20
STANDARD PLANS

STRAIGHT CONCRETE ENDWALLS
SINGLE AND DOUBLE 60" PIPE

INDEX
430-031

SHEET
2 of 2

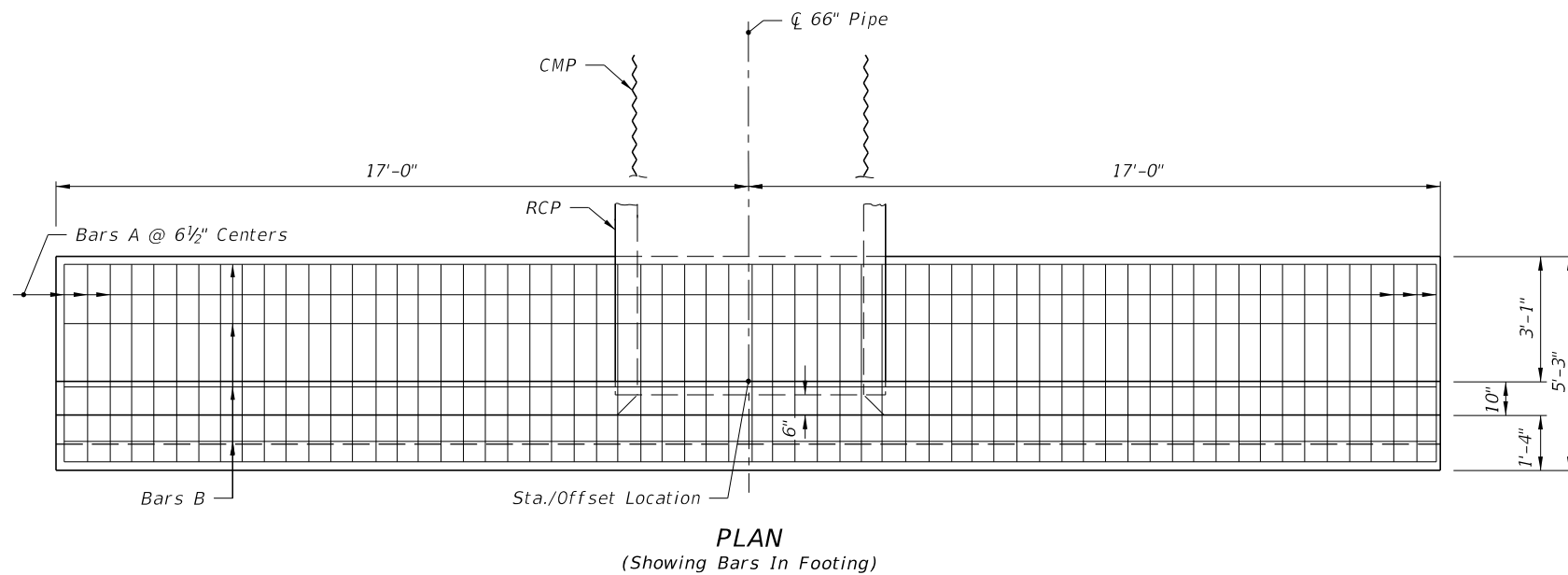
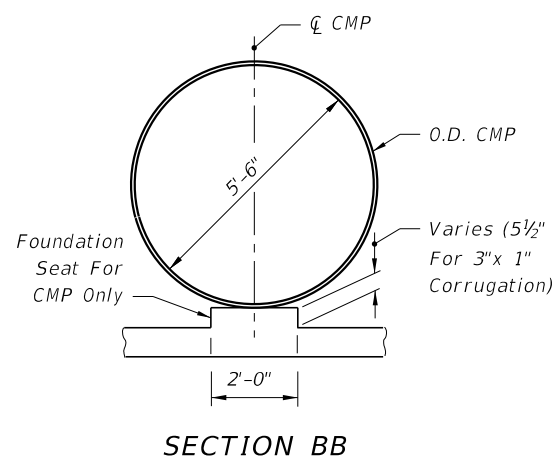

BILL OF REINFORCING STEEL					
MARK	SIZE	NO. REQD.	LENGTH	LOCATION	BENDING
A	5	63	4'-11"	Footing	Straight
B	4	17	33'-8"	Footing & Wall	Straight
C	5	34	9'-11"	Wall	Bend
D	4	20	8'-1"	Wall	Straight
E	4	4	1'-8"	Wall	Straight

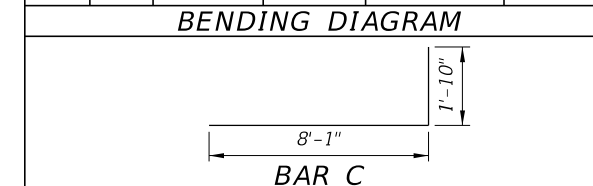

ESTIMATED QUANTITIES				
ITEM	UNIT	RCP	CMP	
Class II Concrete	Cu. Yd.	13.2	13.3	
Reinforcing Steel	Lb.	1170	1170	

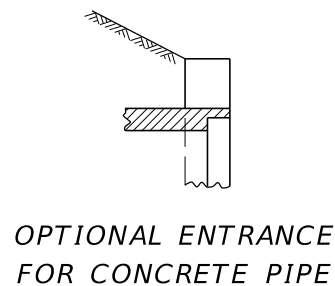
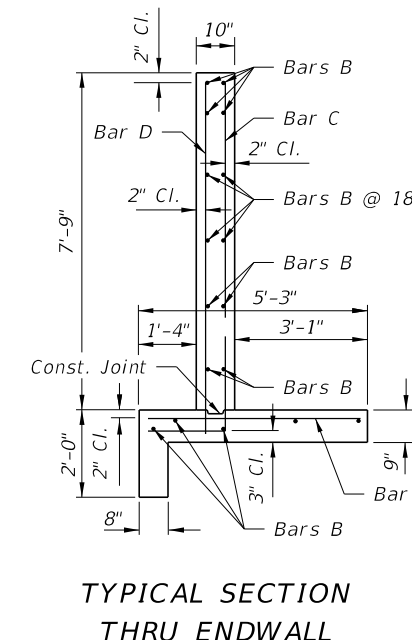
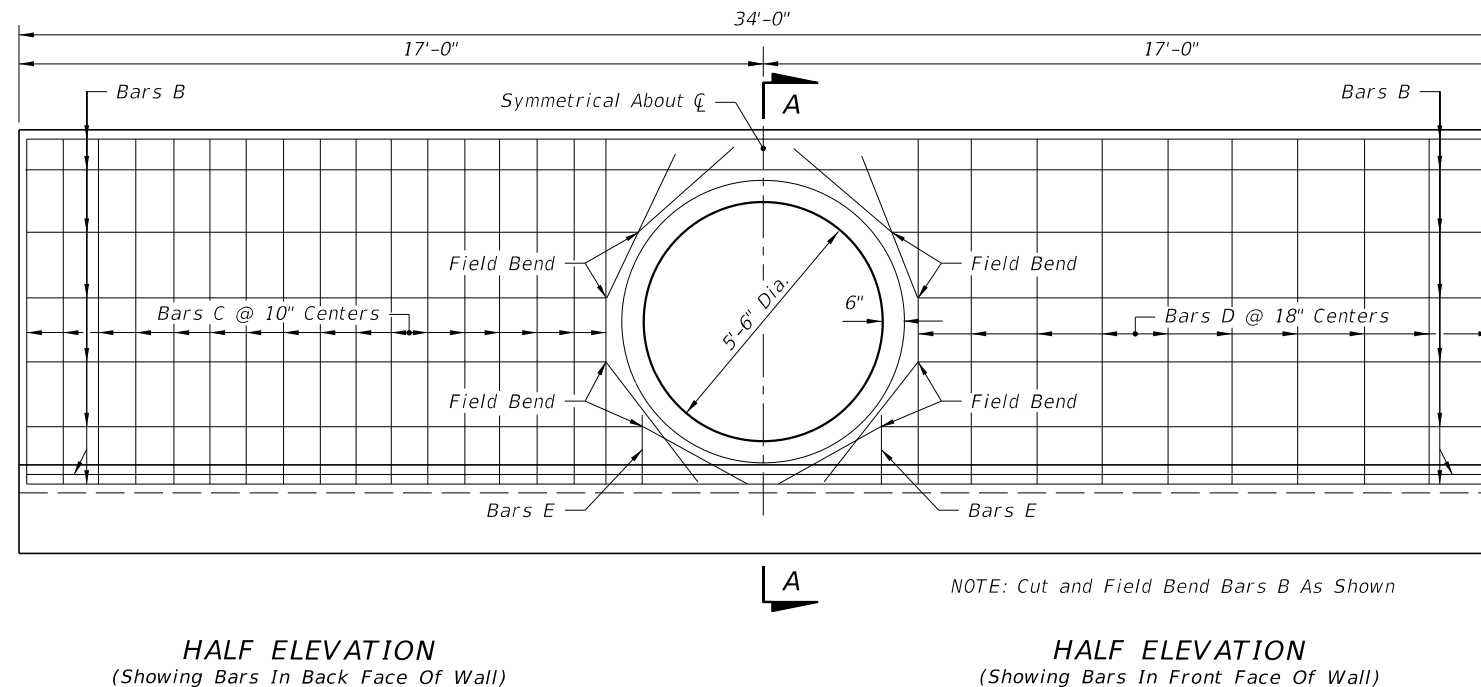
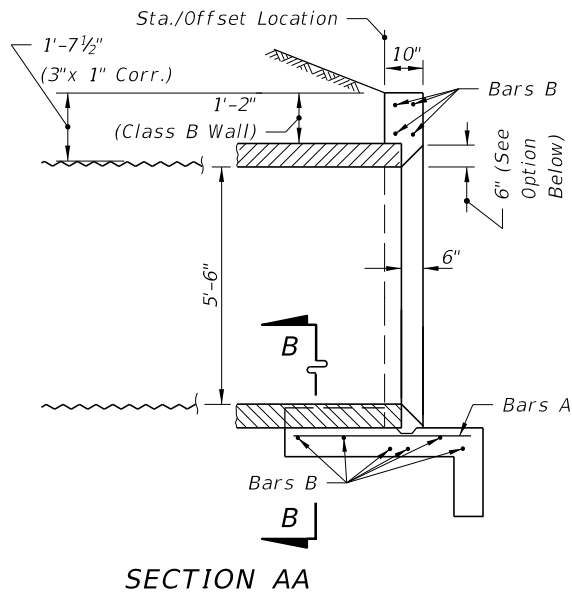

- GENERAL NOTES**
1. Straight concrete endwalls are intended for use outside the clear zone.
 2. Endwalls may be cast-in-place or precast construction. Cast-in-place endwalls shall conform to the details on this Index. Precast construction which adheres to this Index, including any additional reinforcement required for handling which shall be determined by the Contractor or supplier, does not require additional approvals. Deviations from this Index, for precast units, shall require the approval of the State Drainage Engineer prior to construction. For precast construction, see Index 425-001 for opening and grouting details.
 3. Reinforcing steel shall be either Grade 40 or 60.
 4. Concrete shall be Class II except ASTM C478 (4000 psi) concrete may be substituted for precast items manufactured in plants meeting the requirements of Section 449 of the Specifications.
 5. Chamfer: All exposed edges and corners to be chamfered 3/4" unless otherwise shown.
 6. That portion of corrugated Metal pipe in direct contact with the concrete slab and extending 12" beyond shall have a continuous bituminous coating of 0.004" minimum thickness applied prior to placing of the concrete.
 7. Sodding shall be in accordance with Index 524-001 and paid for under the contract unit price for Performance Turf, SY.
 8. Basis of payment for either cast-in-place or precast construction shall be the estimated quantities tabulated on the Index. Concrete and reinforcing steel shall be paid for under the contract unit prices for Class II Concrete (Endwalls), CY and Reinforcing Steel (Roadway), LB.

10/30/2018 8:48:52 AM

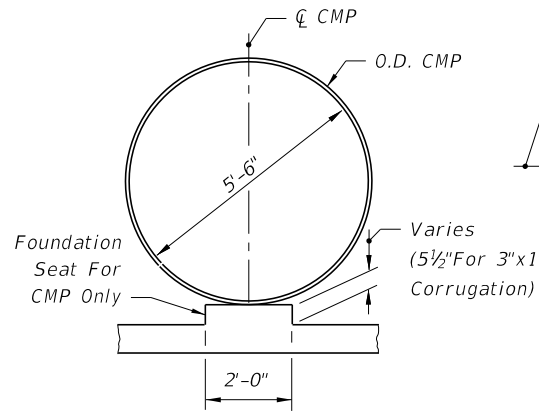

SECTION BB

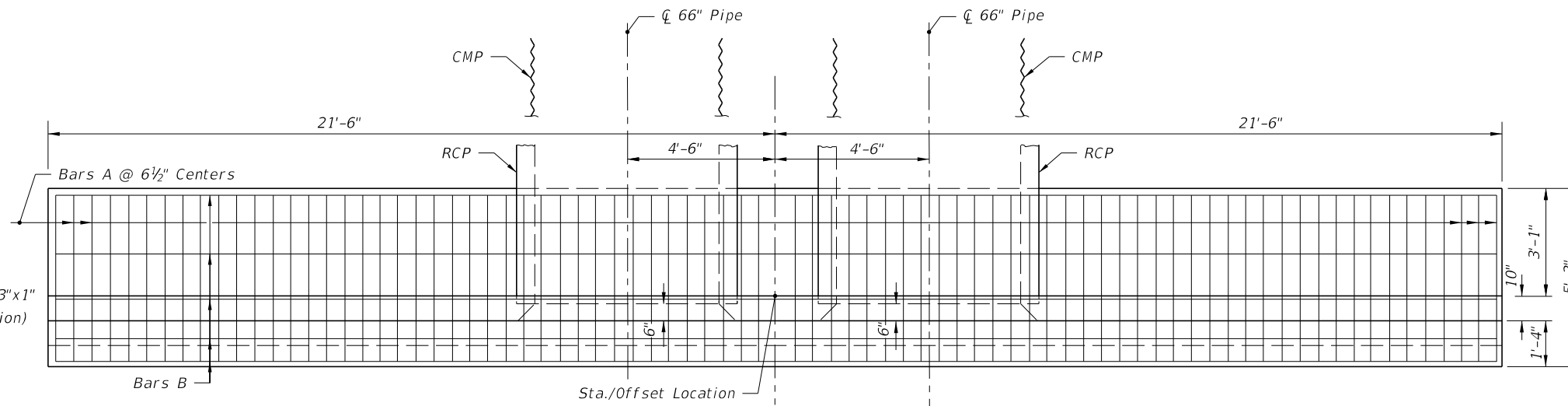

PLAN
(Showing Bars In Footing)

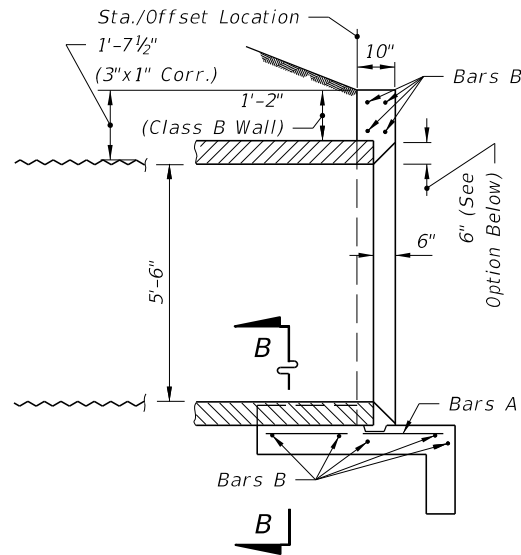

SECTION AA

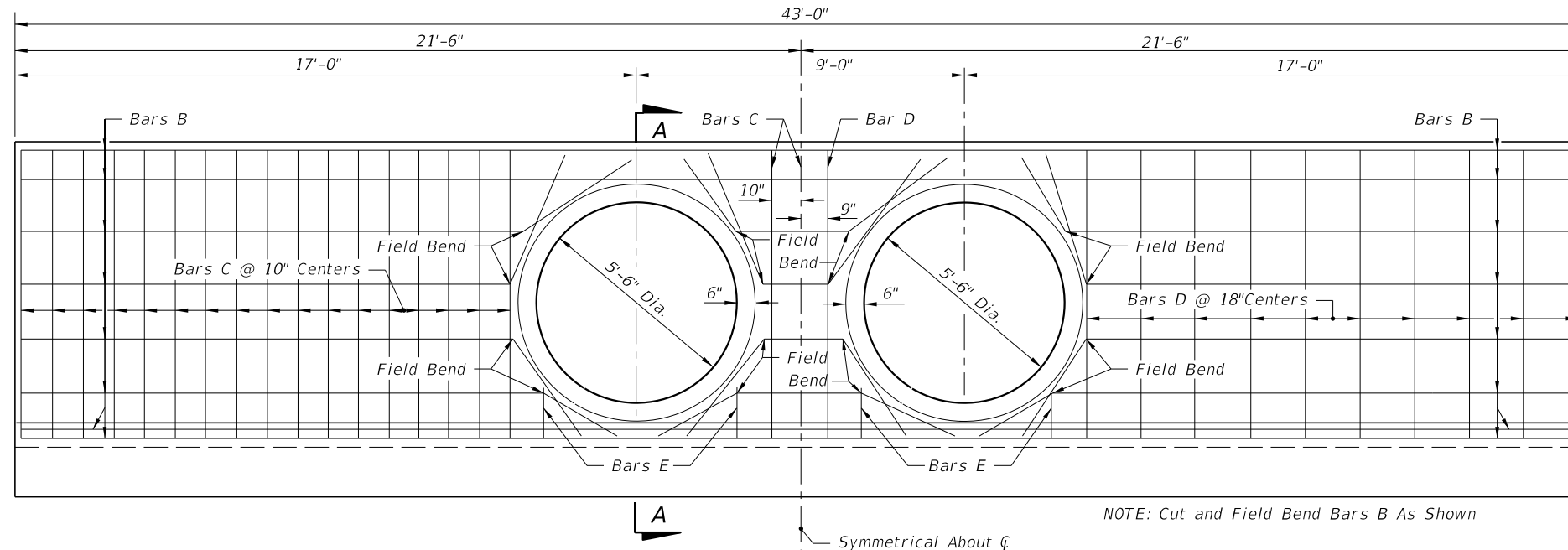

HALF ELEVATION
(Showing Bars In Back Face Of Wall)

HALF ELEVATION
(Showing Bars In Front Face Of Wall)

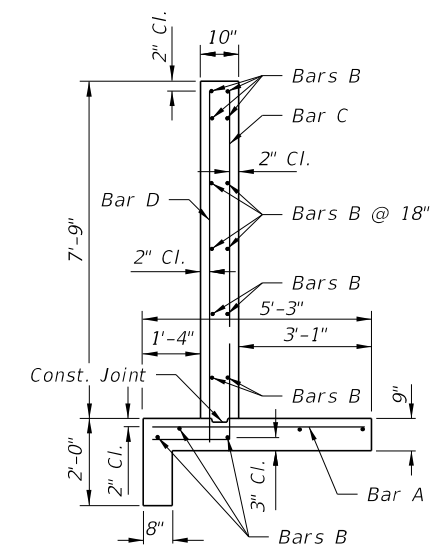

TYPICAL SECTION
THRU ENDWALL

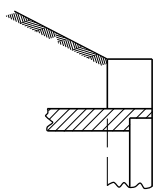

OPTIONAL ENTRANCE
FOR CONCRETE PIPE

BILL OF REINFORCING STEEL						BENDING DIAGRAMS		ESTIMATED QUANTITIES			
MARK	SIZE	NO. REQD.	LENGTH	LOCATION	BENDING			ITEM	UNIT	RCP	CMP
A	5	80	4'-11"	Footing	Straight			Class II Concrete	Cu. Yd.	16.0	16.2
B	4	17	42'-8"	Footing & Wall	Straight			Reinforcing Steel	Lb.	1,406	1,406
C	5	37	9'-11"	Wall	Bend						
D	4	22	8'-1"	Wall	Straight						
E	4	8	1'-8"	Wall	Straight						

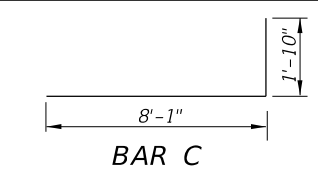

Note: All bar dimensions are out to out

NOTE: See Sheet 1 of 2 for General Notes.

10/30/2018 8:48:55 AM

LAST REVISION 11/01/17	DESCRIPTION:
---------------------------	--------------

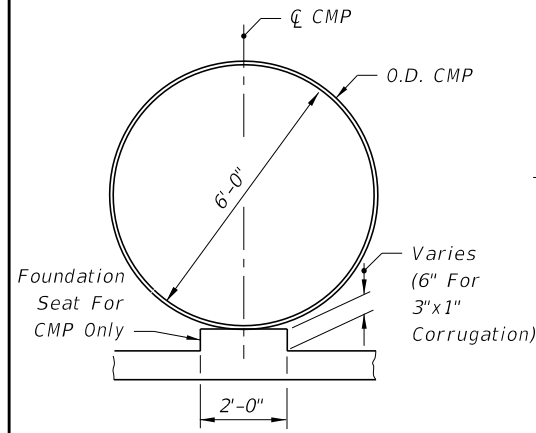

SECTION BB

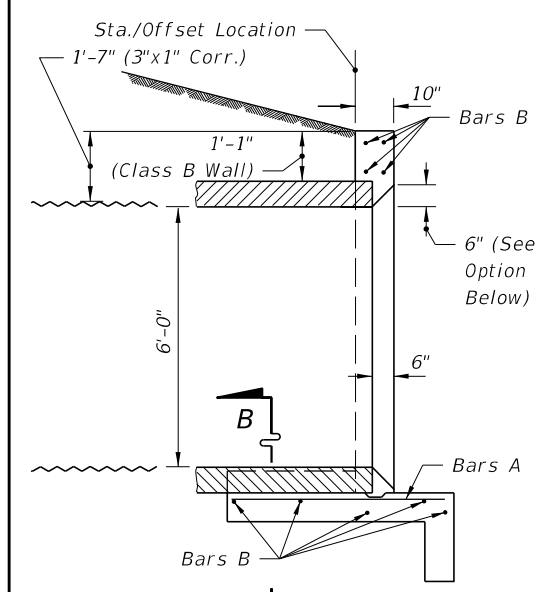

SECTION AA

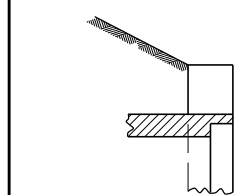

OPTIONAL ENTRANCE FOR CONCRETE PIPE

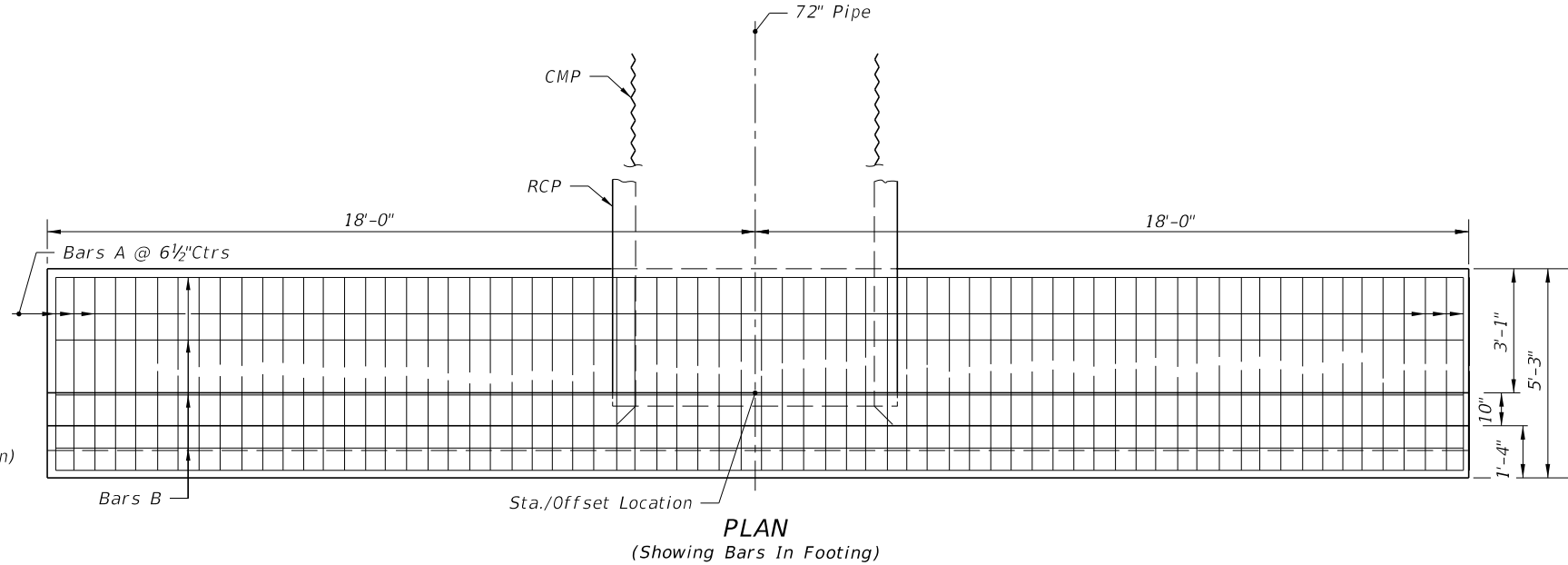

PLAN
(Showing Bars In Footing)

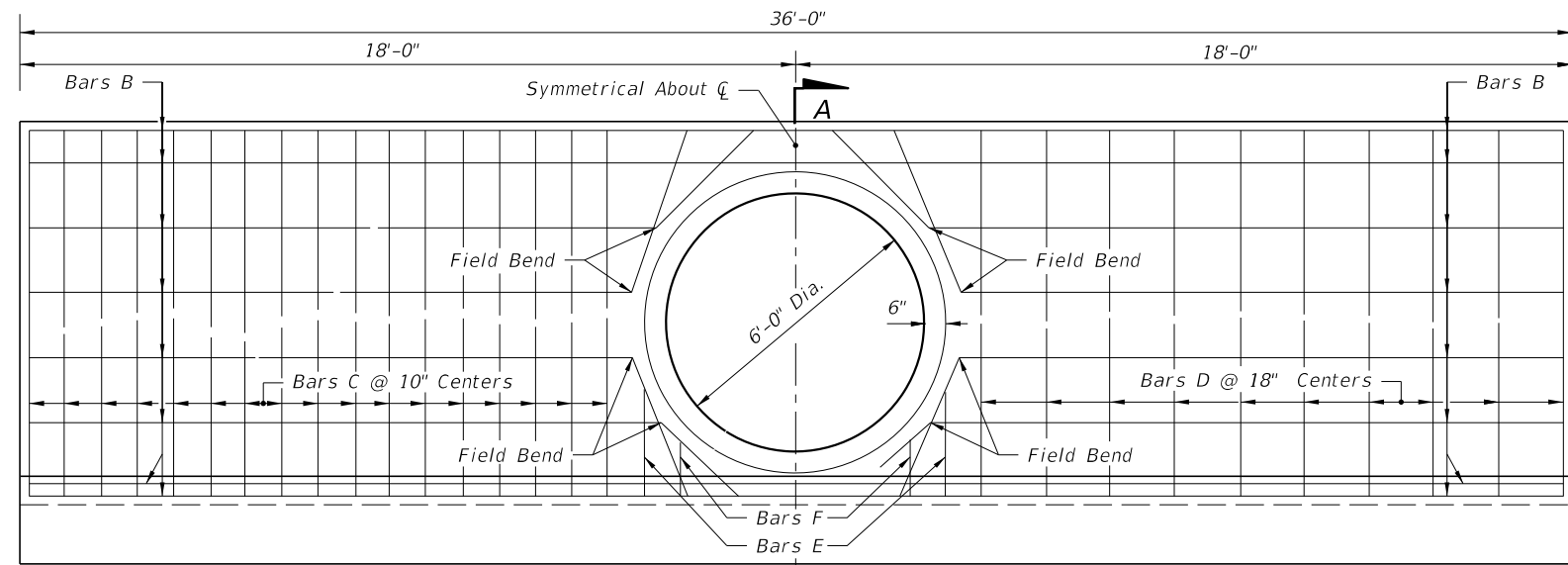

HALF ELEVATION
(Showing Bars In Back Face Of Wall)

HALF ELEVATION
(Showing Bars In Front Face Of Wall)

NOTE: Cut and Field Bend Bars B As Shown

BILL OF REINFORCING STEEL					
MARK	SIZE	NO. REQD.	LENGTH	LOCATION	BENDING
A	5	68	4'-11"	Footing	Straight
B	4	17	35'-8"	Footing & Wall	Straight
C	5	34	10'-5"	Wall	Bend
D	4	20	8'-7"	Wall	Straight
E	4	4	2'-6"	Wall	Straight
F	4	4	1'-6"	Wall	Straight

BENDING DIAGRAM

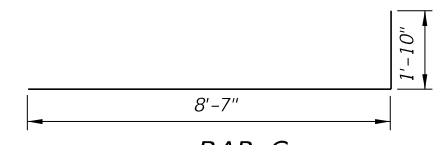

BAR C

NOTE: All bar dimensions are out to out

ESTIMATED QUANTITIES

ITEM	UNIT	RCP	CMP
Class II Concrete	Cu. Yd.	14.4	14.5
Reinforcing Steel	Lb.	1249	1249

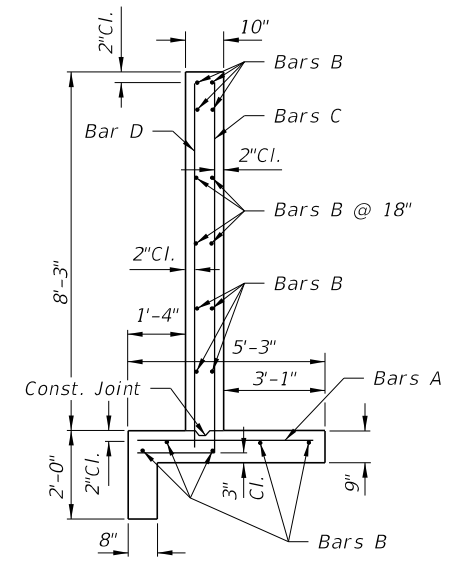

TYPICAL SECTION THRU ENDWALL

GENERAL NOTES

1. Straight concrete endwalls are intended for use outside the clear zone.
2. Endwalls may be cast-in-place or precast construction. Cast-in-place endwalls shall conform to the details on this Index. Precast construction which adheres to this Index, including any additional reinforcement required for handling which shall be determined by the Contractor or supplier, does not require additional approvals. Deviations from this Index, for precast units, shall require the approval of the State Drainage Engineer prior to construction. For precast construction, see Index 425-001 for opening and grouting details.
3. Reinforcing steel shall be either Grade 40 or 60.
4. Concrete shall be Class II, except ASTM C478 (4000 psi) concrete may be substituted for precast items manufactured in plants meeting the requirements of Section 449 of the Specifications.
5. Chamfer: All exposed edges and corners to be chamfered 3/4" unless otherwise shown.
6. That portion of corrugated Metal pipe in direct contact with the concrete slab and extending 12" beyond shall have a continuous bituminous coating of 0.004" minimum thickness coated applied prior to placing of the concrete.
7. Sodding shall be in accordance with Index 524-001 and paid for under the contract unit price for Performance Turf, SY.
8. Basis of payment for either cast-in-place or precast construction shall be the estimated quantities tabulated on the Index. Concrete and reinforcing steel shall be paid for under the contract unit prices for Class II Concrete (Endwalls), CY and Reinforcing Steel (Roadway), LB.

10/30/2018 8:49:00 AM

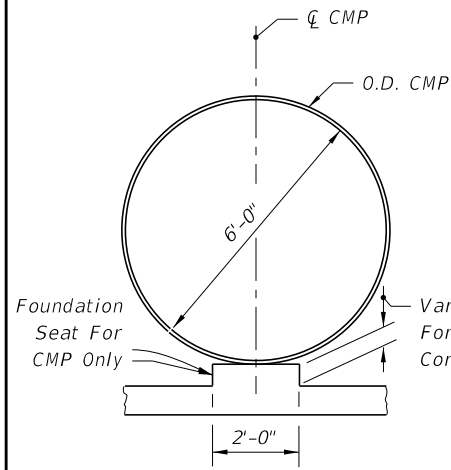

SECTION BB

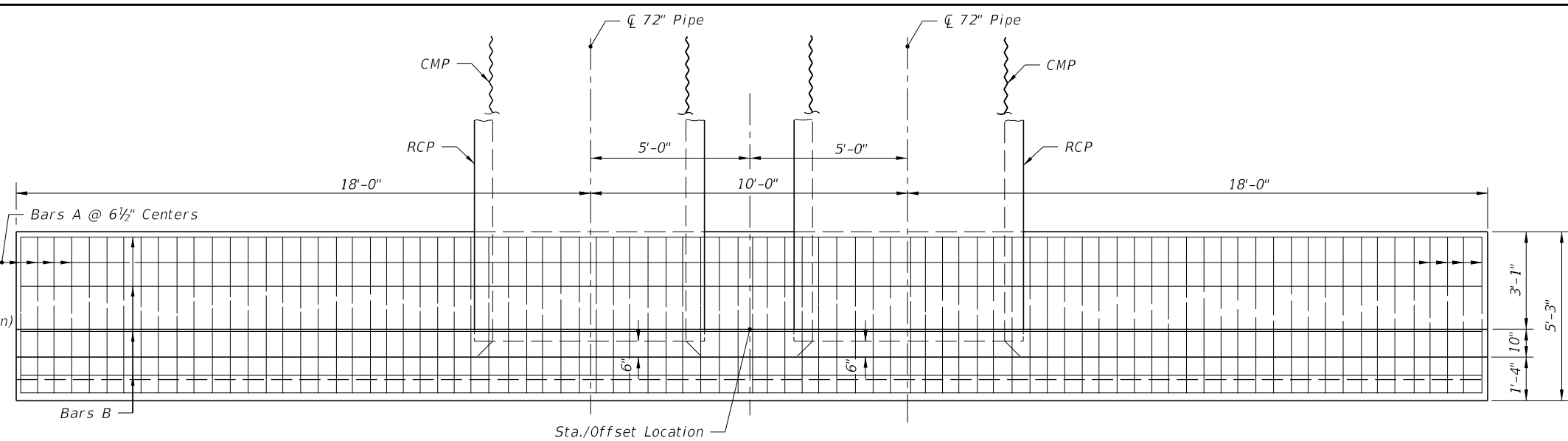

PLAN
(Showing Bars In Footing)

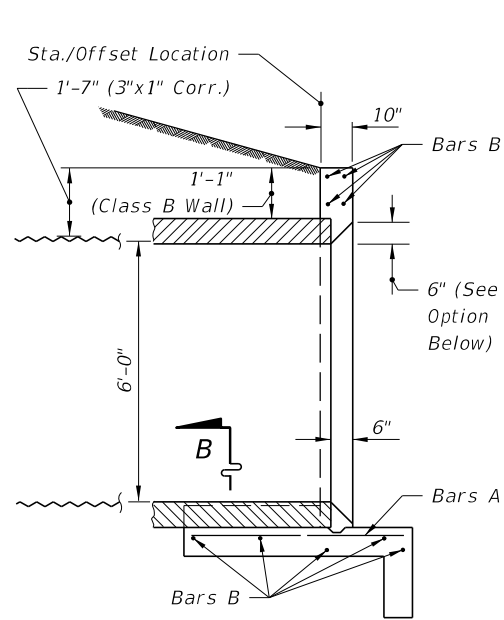

SECTION AA

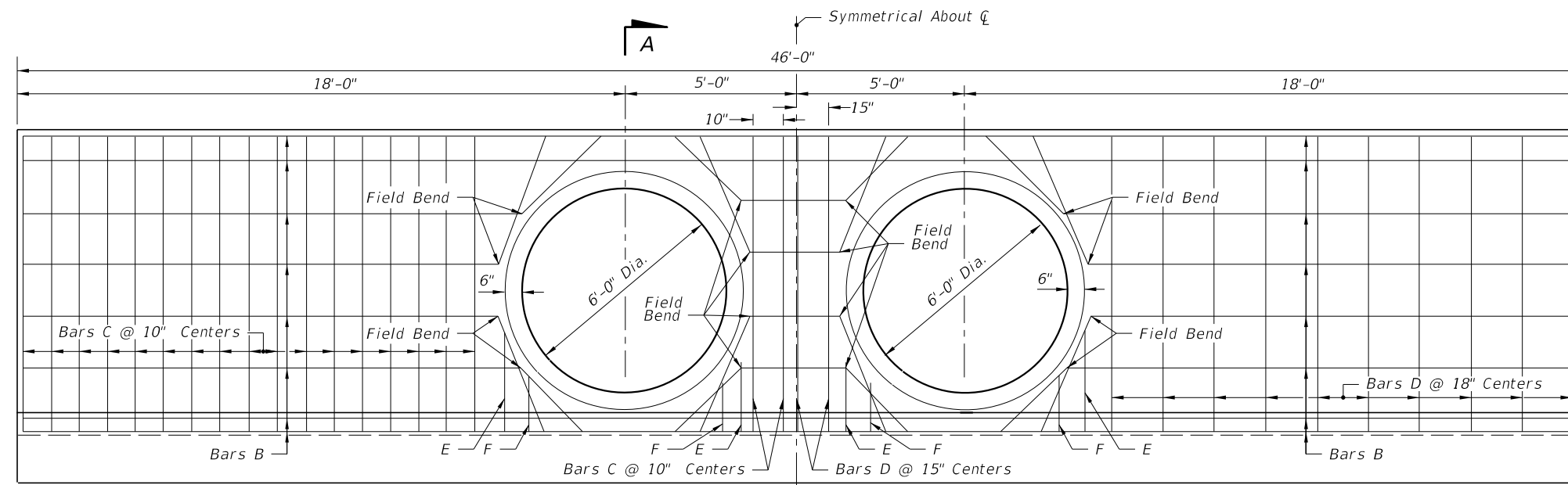

HALF ELEVATION
(Showing Bars In Back Face Of Wall)

HALF ELEVATION
(Showing Bars In Front Face Of Wall)

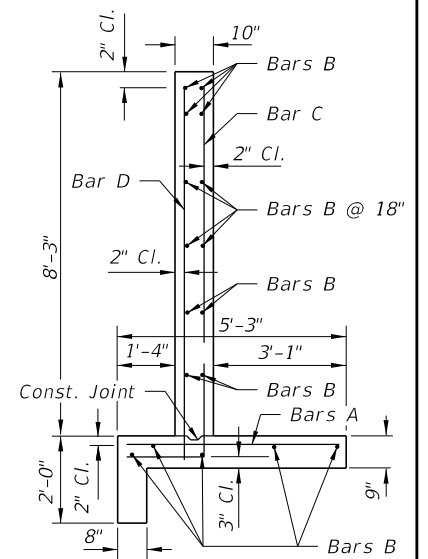

TYPICAL SECTION
THRU ENDWALL

OPTIONAL ENTRANCE
FOR CONCRETE PIPE

BILL OF REINFORCING STEEL					
MARK	SIZE	NO. REQD.	LENGTH	LOCATION	BENDING
A	5	85	4'-11"	Footing	Straight
B	4	17	45'-8"	Footing & Wall	Straight
C	5	38	10'-5"	Wall	Bend
D	4	23	8'-7"	Wall	Straight
E	4	8	2'-6"	Wall	Straight
F	4	8	1'-6"	Wall	Straight

BENDING DIAGRAM

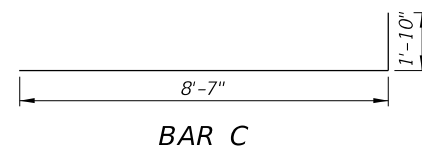

NOTE: All bar dimensions are out to out

ESTIMATED QUANTITIES

ITEM	UNIT	RCP	CMP
Concrete Class II	Cu. Yd.	17.5	17.8
Reinforcing Steel	Lb.	1519	1519

NOTE: See Sheet 1 of 2 for General Notes.

10/30/2018 8:49:03 AM

LAST REVISION	DESCRIPTION:
11/01/17	

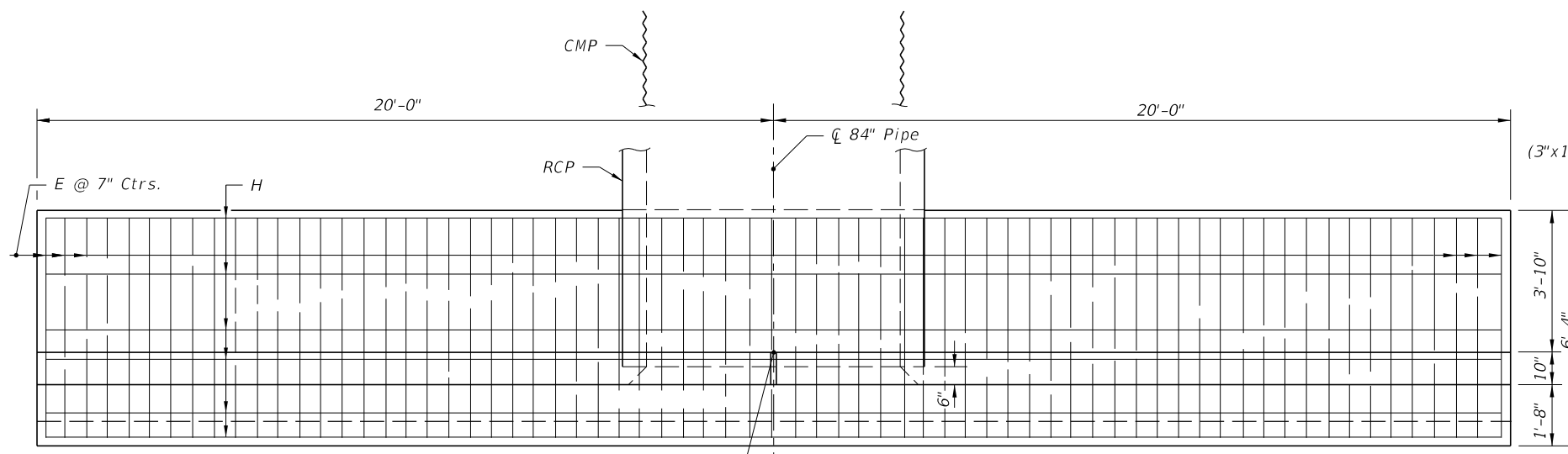

PLAN
(Showing Bars In Footing)

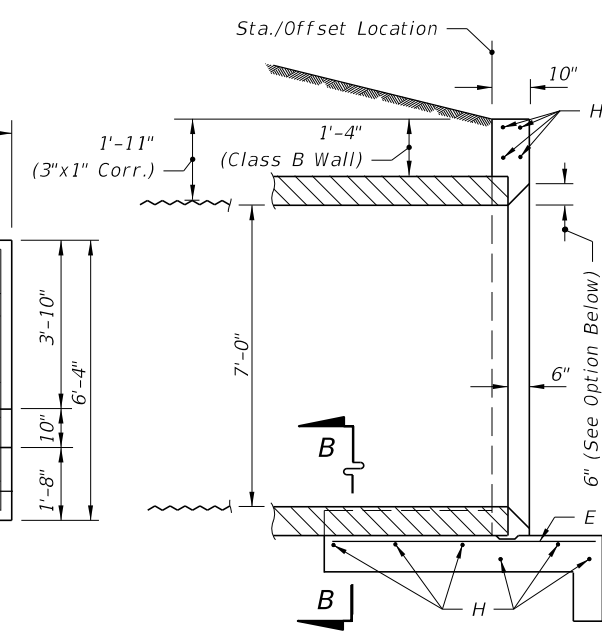

SECTION AA

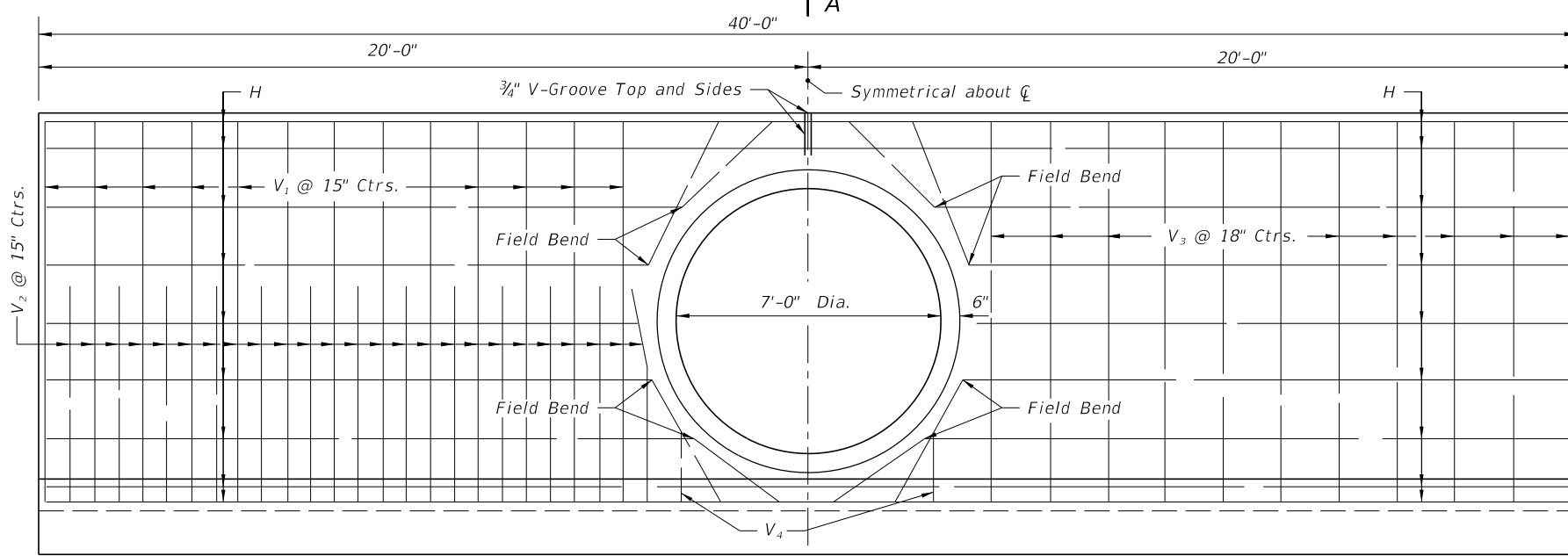

HALF ELEVATION
(Showing Bars In Back Face Of Wall)

Note: Cut and field bend Bars H as shown

HALF ELEVATION
(Showing Bars In Front Face Of Wall)

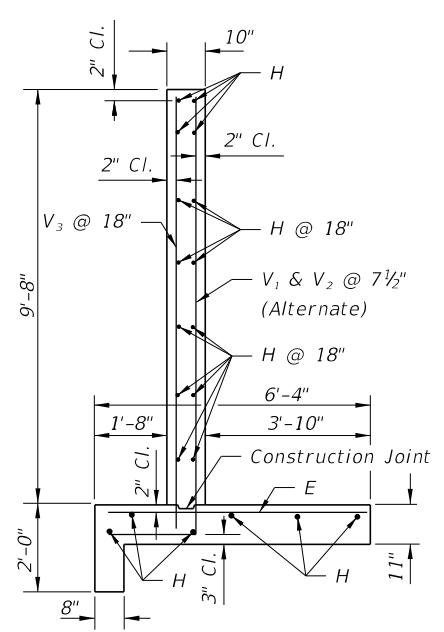

TYPICAL SECTION THRU ENDWALL

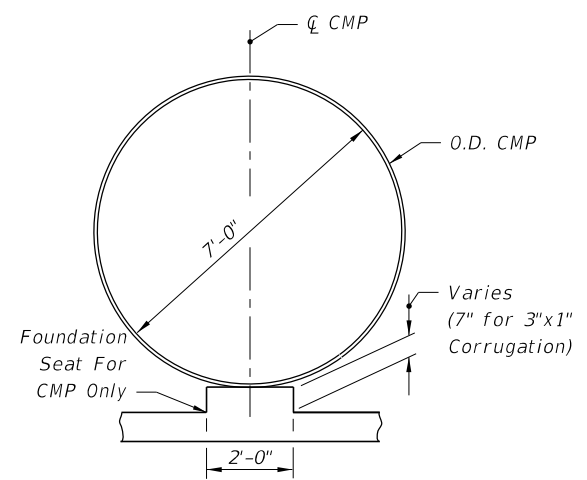

SECTION BB

BILL OF REINFORCING STEEL			
MARK	SIZE	NO. REQD.	LENGTH
E	6	69	6'-0"
H	4	20	39'-8"
V ₁	6	26	12'-4"
V ₂	6	26	7'-10"
V ₃	4	22	10'-2"
V ₄	4	4	2'-0"

BENDING DIAGRAM

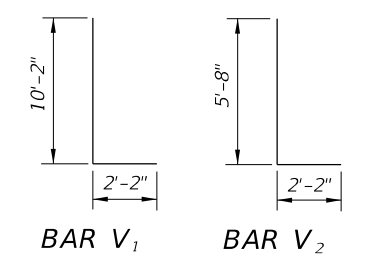

NOTE: All bar dimensions are out to out

ESTIMATED QUANTITIES

ITEM	UNIT	RCP	CMP
Class II Concrete	Cu. Yd.	20.0	20.2
Reinforcing Steel	Lb.	2,095	2,095

GENERAL NOTES

1. Straight concrete endwalls are intended for use outside the clear zone.
2. Endwalls may be cast-in-place or precast construction. Cast-in-place endwalls shall conform to the details on this index, design specifications AASHTO 1989. Precast construction which adheres to this Index, including any additional reinforcement required for handling which shall be determined by the Contractor or supplier, does not require additional approvals. Deviations from this Index, for precast units, shall require the approval of the State Drainage Engineer prior to construction. For precast construction, see Index 425-001 for opening and grouting details.
3. Reinforcing steel shall be either Grade 40 or 60.
4. Concrete shall be Class II, except ASTM C478 (4000 psi) concrete may be substituted for precast items manufactured in plants meeting the requirements of Section 449 of the Specifications.
5. Chamfer: All exposed edges and corners to be chamfered 3/4" unless otherwise shown.
6. That portion of corrugated metal pipe in direct contact with the concrete slab and extending 12" beyond shall have a continuous bituminous coating of 0.004" minimum thickness applied prior to placing of the concrete.
7. Sodding shall be in accordance with Index 524-001 and paid for under the contract unit price for Performance Turf, SY.
8. Basis of payment for either cast-in-place or precast construction shall be the estimated quantities tabulated on the Index. Concrete and reinforcing steel shall be paid for under the contract unit prices for Class II Concrete (Endwalls), CY and Reinforcing Steel (Roadway), LB.

OPTIONAL ENTRANCE FOR CONCRETE PIPE

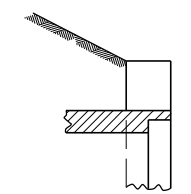

10/30/2018 8:49:08 AM

LAST REVISION 11/01/17	DESCRIPTION:		FY 2019-20 STANDARD PLANS	STRAIGHT CONCRETE ENDWALL SINGLE 84" PIPE	INDEX 430-034	SHEET 1 of 1
---------------------------	--------------	--	--------------------------------------	------------------------------------------------------	------------------	-----------------

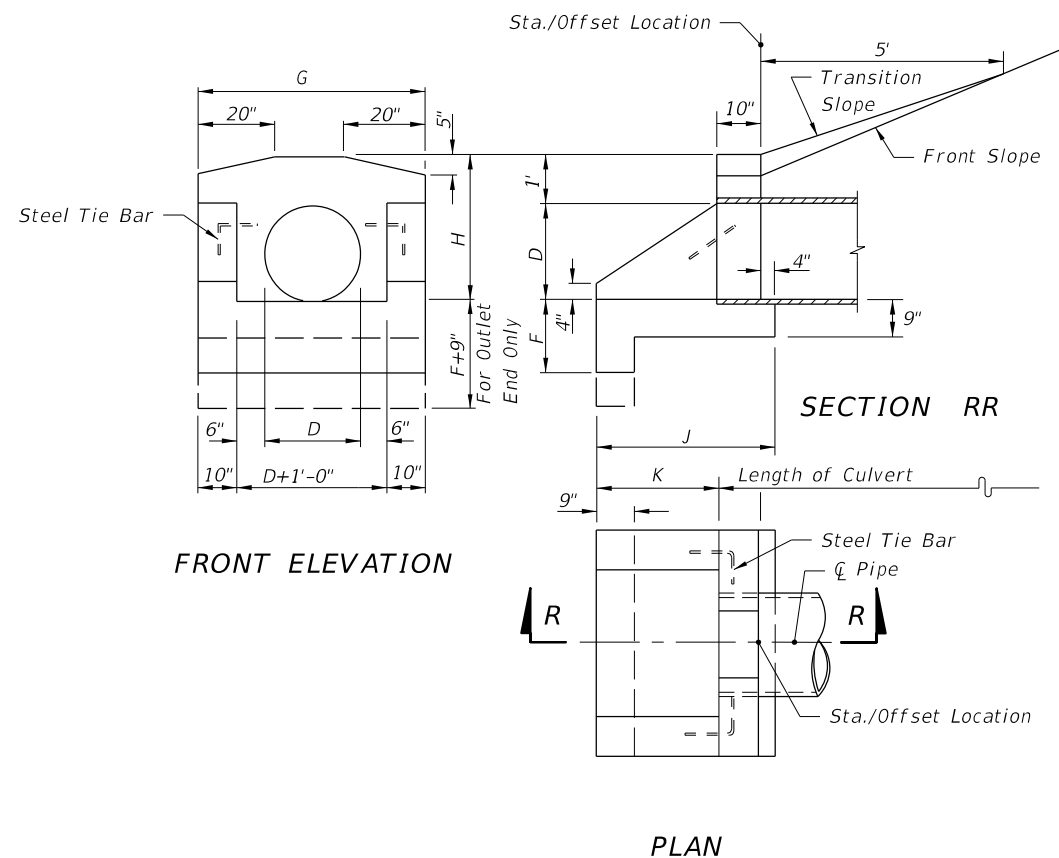

CONCRETE ENDWALL WITH U-TYPE WINGS FOR PIPE CULVERTS

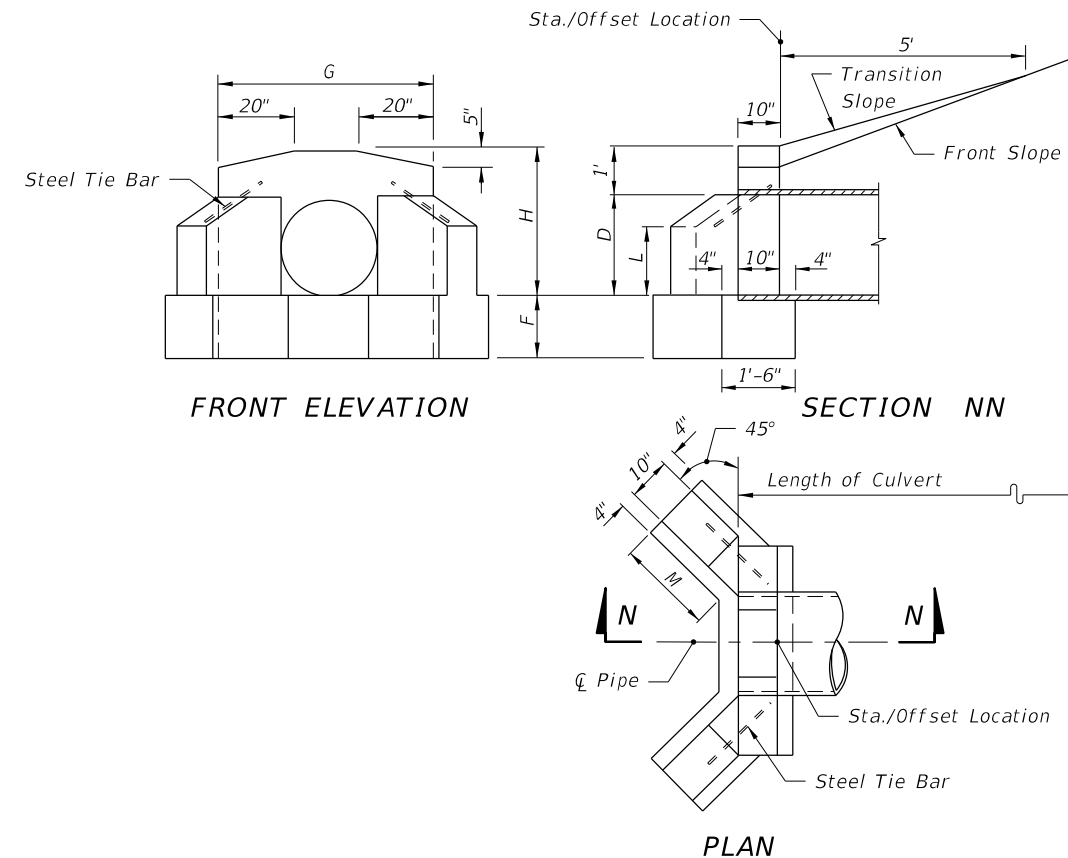

CONCRETE ENDWALL WITH 45° WINGS FOR PIPE CULVERTS

TABLE OF DIMENSIONS AND ESTIMATED QUANTITIES
PIPE CULVERT ENDWALLS WITH U-TYPE WINGS

DIMENSIONS				QUANTITIES IN ONE ENDWALL									
Opening		Wall		Footing		Concrete, Class 1, Total (CY)						Steel Tie Bars	
D	Area (ft ²)	G	H	K	F	J	RCP		CMP		CIP		
							Inlet	Outlet	Inlet	Outlet	Inlet	Outlet	
12"	0.8	3'-8"	2'-0"	1'-0"	1'-3"	2'-2"	0.48	0.55	0.49	0.57	0.49	0.57	none
15"	1.2	3'-11"	2'-3"	1'-5"	1'-3"	2'-7"	0.59	0.67	0.62	0.70	0.61	0.70	none
18"	1.8	4'-2"	2'-6"	1'-9"	1'-3"	2'-11"	0.70	0.79	0.74	0.82	0.74	0.82	none
24"	3.1	4'-8"	3'-0"	2'-6"	1'-6"	3'-8"	1.01	1.11	1.06	1.16	1.06	1.16	2-#6 Bars x 2'-0"
30"	4.9	5'-2"	3'-6"	3'-3"	1'-6"	4'-5"	1.33	1.44	1.41	1.51	1.40	1.51	2-#6 Bars x 2'-0"
36"	7.1	5'-8"	4'-0"	4'-0"	1'-9"	5'-2"	1.73	1.85	1.84	1.96	1.82	1.94	2-#6 Bars x 2'-6"
42"	9.6	6'-2"	4'-6"	4'-9"	2'-0"	5'-11"	2.19	2.32	2.32	2.45			2-#6 Bars x 2'-6"
48"	12.6	6'-8"	5'-0"	5'-6"	2'-0"	6'-8"	2.64	2.78	2.81	2.95			2-#6 Bars x 3'-0"

TABLE OF DIMENSIONS AND ESTIMATED QUANTITIES
PIPE CULVERT ENDWALLS WITH 45° WINGS

DIMENSIONS				QUANTITIES IN ONE ENDWALL						
Opening		Wall			Footing	Concrete, Class 1			Steel Tie Bars	
D	Area (ft ²)	H	G	L	M	F	Total (CY)			
							RCP	CMP	CIP	
15"	1.2	2'-3"	3'-7"	1'-0"	1'-3"	1'-3"	0.56	0.59	0.59	none
18"	1.8	2'-6"	3'-10"	1'-2"	1'-7"	1'-3"	0.74	0.77	0.77	none
24"	3.1	3'-0"	4'-4"	1'-5"	2'-1"	1'-4"	1.01	1.06	1.06	2 -#6 Bars x 2'-0"
30"	4.9	3'-6"	4'-10"	1'-9"	2'-5"	1'-6"	1.32	1.40	1.39	2 -#6 Bars x 2'-0"
36"	7.1	4'-0"	5'-4"	2'-0"	2'-11"	1'-8"	1.72	1.83	1.82	2 -#6 Bars x 2'-6"
42"	9.6	4'-6"	5'-10"	2'-3"	3'-6"	2'-0"	2.34	2.47		2 -#6 Bars x 2'-6"
48"	12.6	5'-0"	6'-4"	2'-6"	4'-0"	2'-0"	2.74	2.90		2 -#6 Bars x 2'-6"

GENERAL NOTES

1. Winged concrete endwalls are intended for use outside the clear zone.
2. Chamfer all exposed edges 3/4".
3. Concrete shall be Class 1, except ASTM C478 (4000 psi) Concrete may be substituted for precast items manufactured in plants meeting the requirements of Section 449 of the Specifications.
4. Endwall to be paid for under the contract unit price for Class 1 Concrete.
5. Sodding to be in accordance with Index 524-001, and paid for under the contract unit price for Performance Turf, SY.

10/30/2018 8:49:11 AM

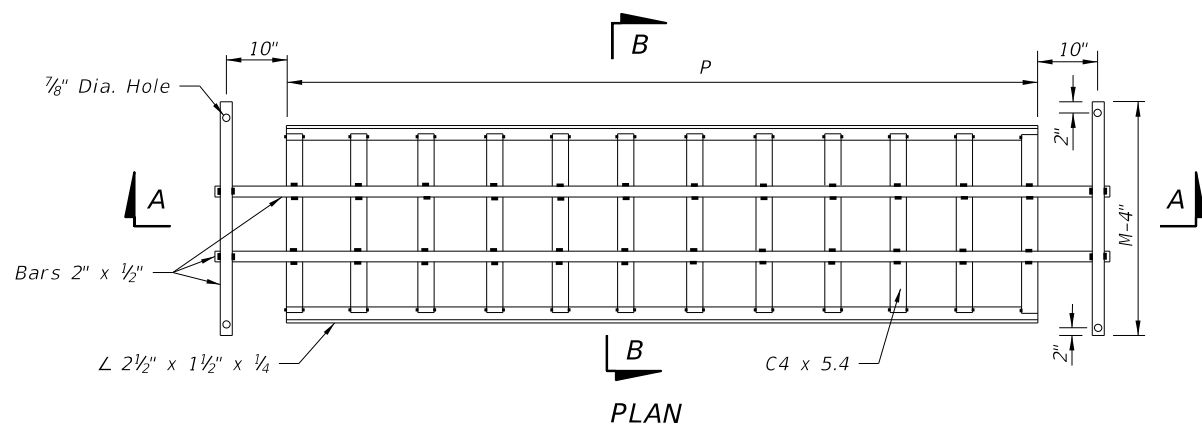

PLAN

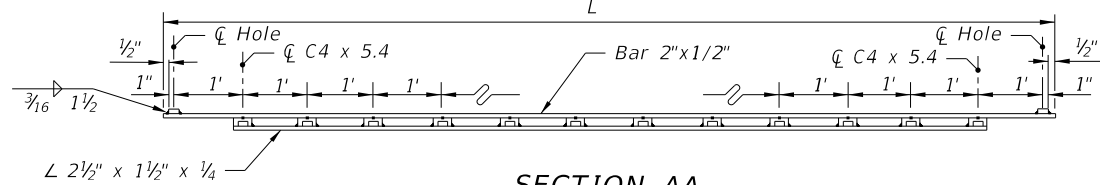

SECTION AA

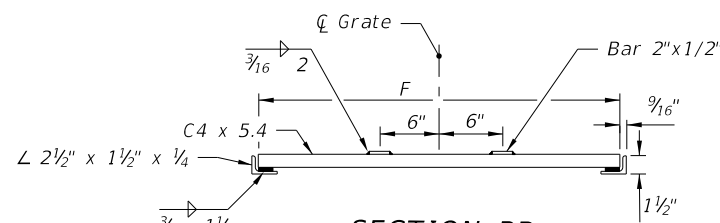

SECTION BB
GRATE DETAIL

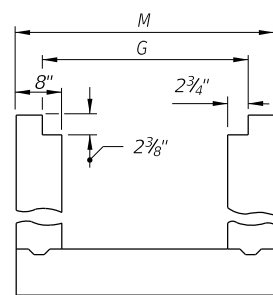

GRATE SEAT DETAIL

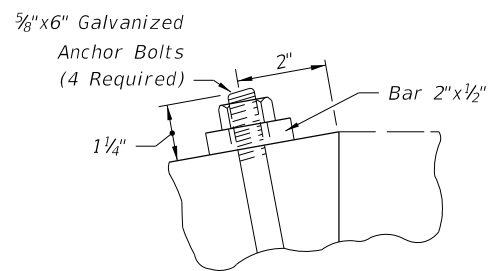

ANCHOR BOLT DETAIL

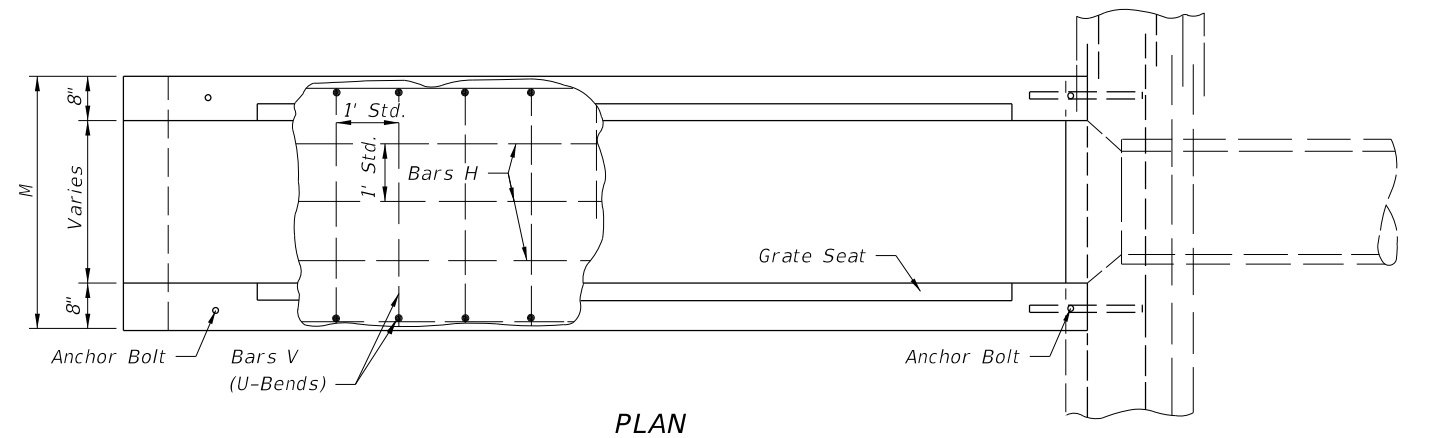

PLAN

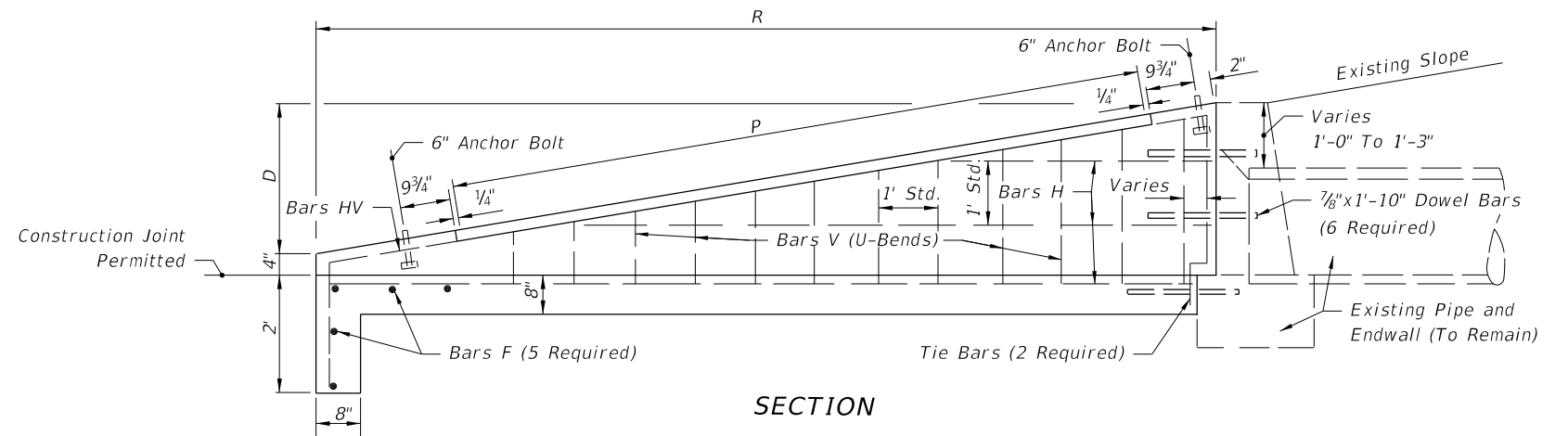

SECTION

GENERAL NOTES

1. For use criteria see "Steel Grating Use Criteria" Index 430-011.
2. Grates shall be ASTM A242, A572 or A588, Grade 50 steel, and galvanized in accordance with Section 975 and 425-3.2 of the Standard Specifications.
3. Channel section C3 x 6.0 may be substituted for the C4 x 5.4 channel.
4. All steel reinforcing bars are #4 with 2" cover except as noted. Spacings shown are center to center. Laps to be 1'-5" minimum. Welded wire fabric (two cages max.) with an equivalent cross section area (0.20 sq. in.) may be substituted for bar reinforcement.
5. Drill 1 1/4" holes 8" deep with a rotary drill in existing endwall for dowel bars. Holes shall be thoroughly cleaned prior to installing Adhesive-Bonded Dowels.
6. Endwall to be paid for under the contract unit price for Class I Concrete (Endwalls), CY and Reinforcing Steel (Roadway), LB. Cost of Adhesive-Bonded Dowels to be included in the contract unit price for reinforcing steel. Cost of grates to be paid for under the contract unit price for Endwall Grate, LB., plan quantity. Cost of galvanized bolts and nuts to be included in the contract unit price for the grate.
7. Sod slopes 5' each side and above endwall. Sodding to be paid for under the contract unit price for Performance Turf, SY.

DIMENSIONS AND QUANTITIES PER GRATE

Slope	Pipe Size	Channels @ 5.4 Lbs./LF			Bars @ 3.4 lbs/LF (2 ea.)			Angles @ 3.2 Lbs./LF		(2)Total Weight-Lbs
		Quantity	F	Lbs.	L	M-4"	Lbs.	P	Lbs.	
1:6	15"	10	2'-6 7/8"	139	11'-3"	3'-3"	99	9'-4"	60	298
	18"	12	2'-9 7/8"	183	13'-3"	3'-6"	114	11'-4"	73	370
	24"	15	3'-3 7/8"	269	16'-3"	4'-0"	138	14'-4"	92	499
	30"	18	3'-9 7/8"	372	19'-3"	4'-6"	162	17'-4"	111	645
1:4	15"	6	2'-6 7/8"	83	7'-3"	3'-3"	71	5'-4"	34	188
	18"	7	2'-9 7/8"	107	8'-3"	3'-6"	80	6'-4"	41	228
	24"	9	3'-3 7/8"	161	10'-3"	4'-0"	97	8'-4"	53	311
	30"	11	3'-9 7/8"	227	12'-3"	4'-6"	114	10'-4"	66	407

DIMENSIONS AND QUANTITIES PER U-ENDWALL

Pipe Size	G	M	D	R	P	Class I Concrete-CY	Reinforcing Steel-Lbs.	Sod SY
15"	2'-8 1/2"	3'-7"	2'-2"	13'-0"	9'-4"	2.12	167	23
18"	2'-11 1/2"	3'-10"	2'-5"	14'-6"	11'-4"	2.53	173	25
24"	3'-5 1/2"	4'-4"	2'-11"	17'-6"	14'-4"	3.48	238	29
30"	3'-11 1/2"	4'-10"	3'-5"	20'-6"	17'-4"	4.57	315	32
15"	2'-8 1/2"	3'-7"	2'-2"	8'-8"	5'-4"	1.44	120	19
18"	2'-11 1/2"	3'-10"	2'-5"	9'-8"	6'-4"	1.72	130	20
24"	3'-5 1/2"	4'-4"	2'-11"	11'-8"	8'-4"	2.36	167	22
30"	3'-11 1/2"	4'-10"	3'-5"	13'-8"	10'-4"	3.09	225	25

10/30/2018 8:49:15 AM

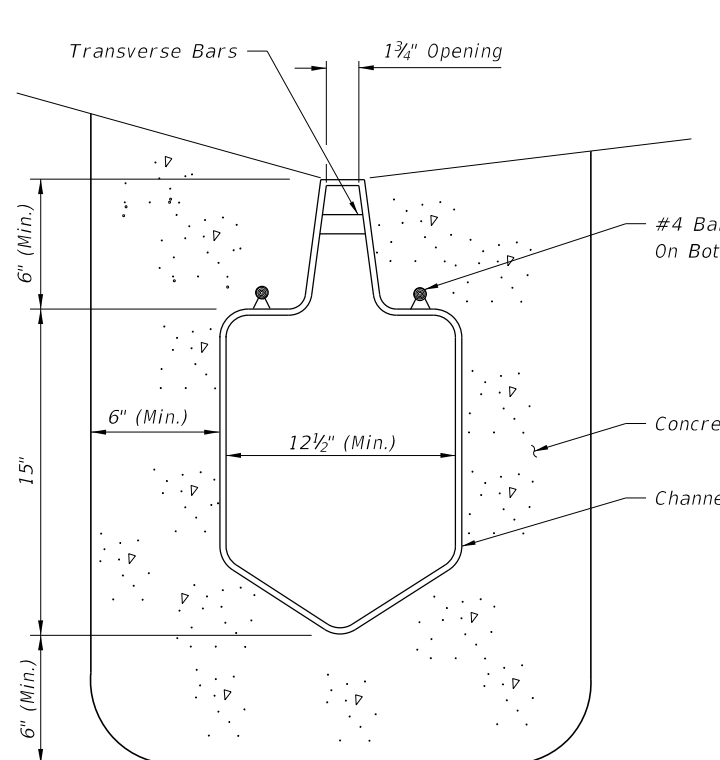

PREFORMED POLYETHYLENE ALTERNATE

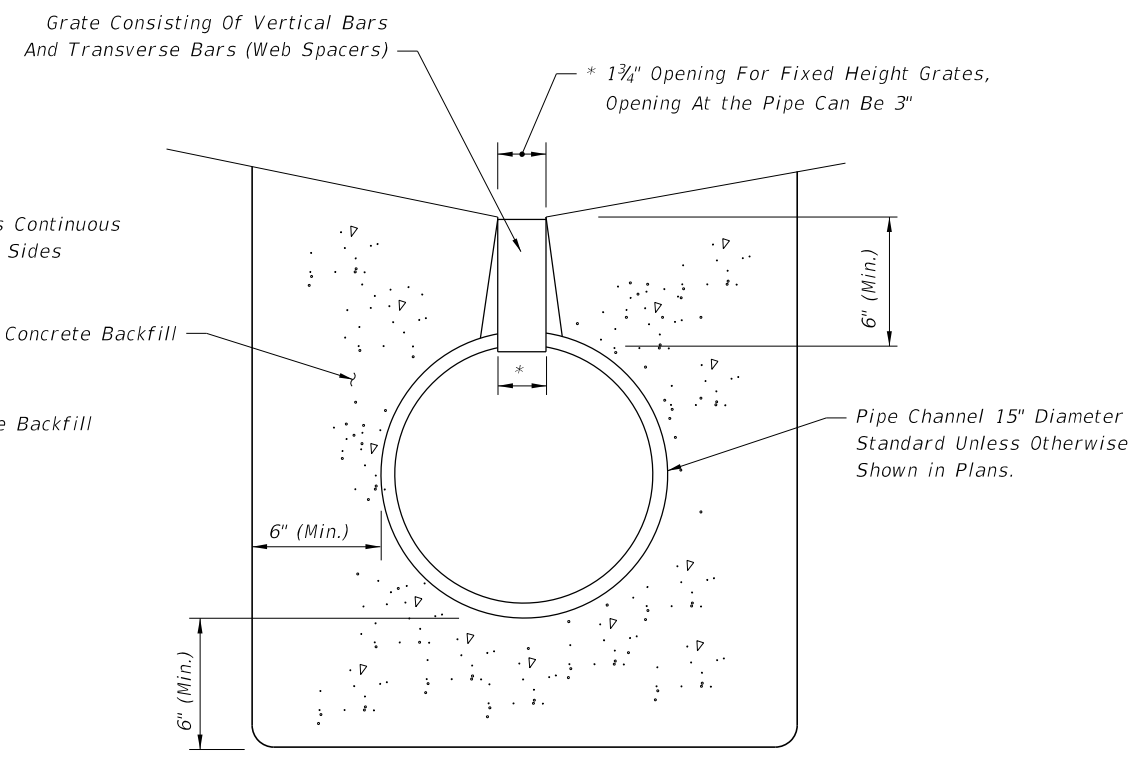

ROUND ALTERNATE

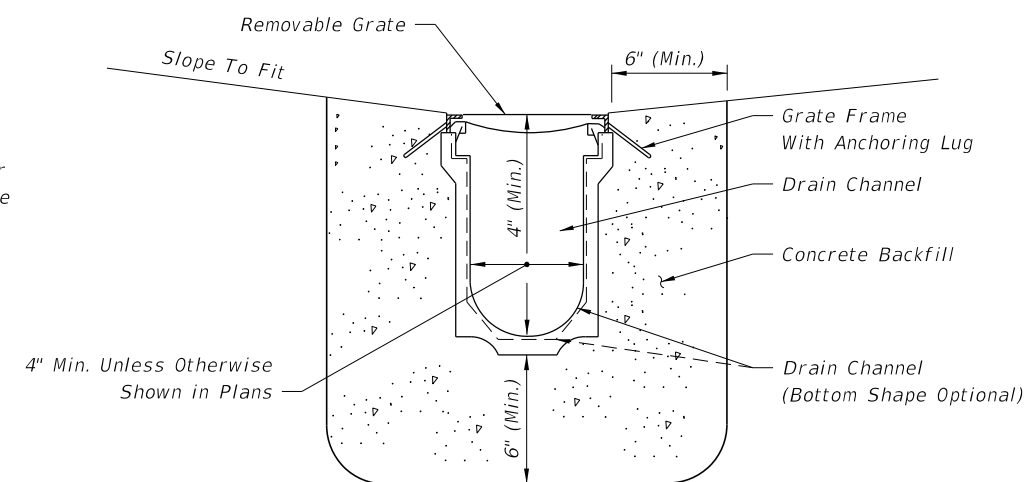

PREFORMED CHANNEL WITH REMOVABLE GRATE

SEE SHEET 2 FOR TYPICAL LOCATIONS

SEE SHEET 2 FOR TYPICAL LOCATIONS

TYPE I (NON-REMOVABLE GRATE)

TYPE II

GENERAL NOTES

1. Trench drain is intended for use in gutters and driveways as shown on the typical locations on Sheet 2. Type I is intended for use in Type E, F and drop curbing, and adjacent to traffic separators and standard barrier walls. The width of the channel grate for Type I Trench Drain shall be 1 3/4" throughout varying the depth of the channel neck. Type II may also be used in those locations if an independent laboratory certifies that the grating used has an open area equal to at least 0.27 square feet per linear foot. Type II is primarily intended for use in valley gutter across driveway openings and drop curbing; Type I may also be used in those locations. The width of the channel grate for Type II Trench Drain shall be the same as the width of the channel. The linear slope or gradient for Type II may be manufactured by varying the depth of the channel. Trench Drain shall not be placed in pedestrian paths unless ADA compliant grates are used.
2. Unless shown in the plans, outlet pipes and preformed channel inverts shall be sloped 0.6% or steeper toward the outlet regardless of the surface slope.
3. Trench drain may be stubbed directly into drainage structures, or outlet pipes may be used to connect trench drain to drainage structures.
4. A cleanout port compatible with the manufactured system shall be provided for Type I drains at the upstream end and at intervals not to exceed 50 feet. The cleanout port shall provide an opening 6" to 10" wide (transverse to the trench drain length) and 18" to 24" long. Where cleanouts are placed adjacent to raised curb or separator, the curb or separator shall be formed around the cleanout. The cleanout shall have a removable load resistant cover or grate.
5. Trench excavation must allow for a minimum of 6" of concrete to be placed under and alongside the trench drain channel system. Concrete backfill shall meet the requirements of Section 347 of the Standard Specifications. At the end of all units (Type I or II), the concrete backfill shall extend 6" minimum past the end of the drain opening.
6. Transverse bars for Type I Trench Drain shall be spaced 4" to 6" on center.
7. Whenever the work disturbs existing conditions or work already completed, restore the same to its original condition in every detail. All such repair and replacement shall meet the approval of the Engineer.

DESIGN NOTES

1. Where placed adjacent to reinforced concrete barrier, designer shall detail in the plans the position of the drain relative to the barrier to avoid conflicts with the foundation. (See Index 521-001)
2. The designer shall identify the following in the plans:
 - (a) The type of drain at each location.
 - (b) The begin and end locations of the Trench Drain.
 - (c) The location of the outlet pipe if the Trench Drain is not stubbed directly into a drainage structure.
 - (d) The design flow (Q) for the Trench Drain must be shown on the plans.
3. Capture efficiency for Type I Trench Drain may be computed using the equations for slotted drain in FHWA's HEC 12 & 22. Grate Type I and Type II must have at least 30% open area.
4. Round pipe alternate is available in 12, 18, 24 and 36 inch.
5. Type II Preformed Channel with integral anchoring lugs are applicable.

10/30/2018 8:49:19 AM

LAST REVISION 11/01/17	REVISION	DESCRIPTION:	 FY 2019-20 STANDARD PLANS	TRENCH DRAIN	INDEX 436-001	SHEET 1 of 2
---------------------------	----------	--------------	-------------------------------------------------------------------------------------------------------------------------------	---------------------	------------------	-----------------

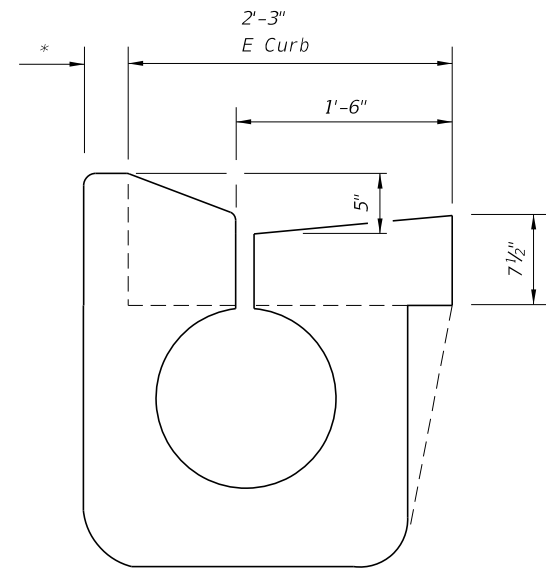

WITHIN TYPE E CURB

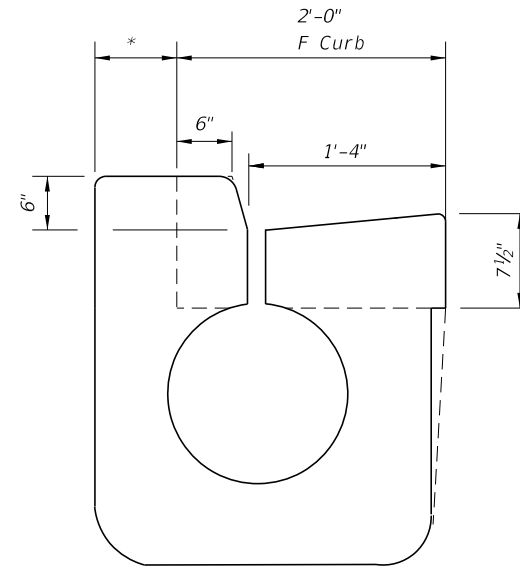

WITHIN TYPE F CURB

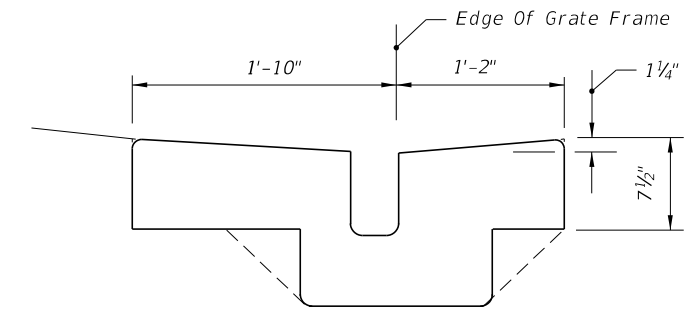

WITHIN VALLEY GUTTER

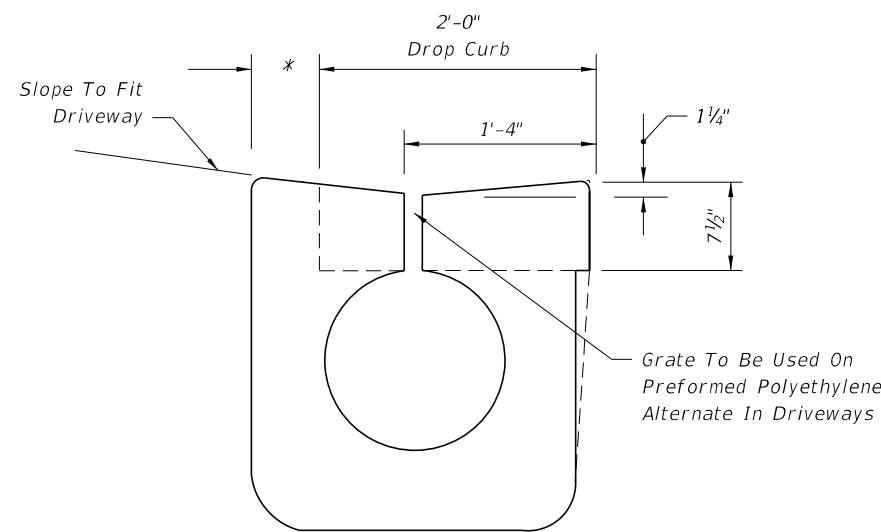

WITHIN DROP CURB

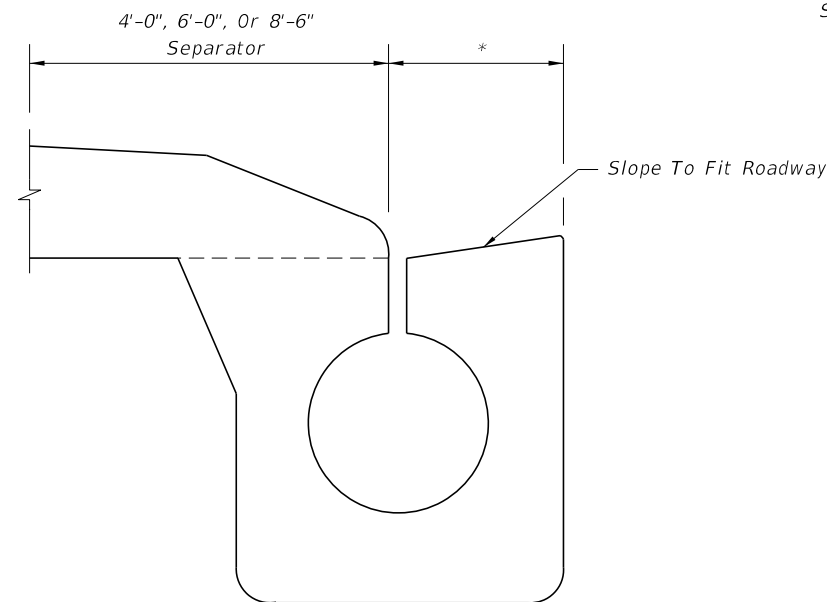

ADJACENT TO TRAFFIC SEPARATOR

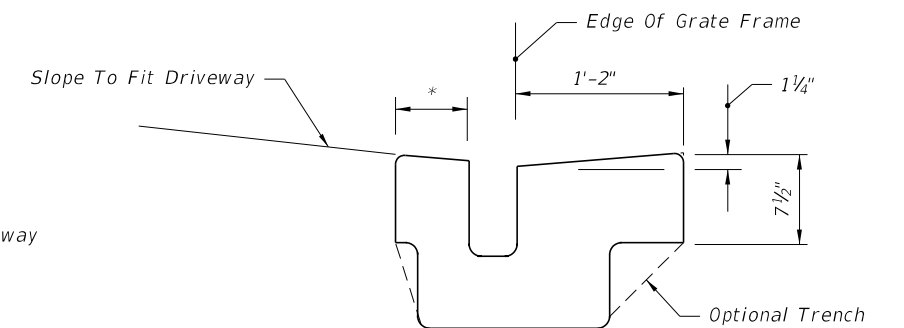

WITHIN DROP CURB
TYPICAL LOCATIONS FOR TYPE II

* As Necessary To Provide 6" Of Concrete
On This Side Of Drain

ROUND PIPE ALTERNATE SHOWN, BUT PREFORMED POLYETHYLENE ALTERNATE ACCEPTABLE

TYPICAL LOCATIONS FOR TYPE I

10/30/2018 8:49:22 AM

LAST REVISION
11/01/17

REVISION

DESCRIPTION:



FY 2019-20
STANDARD PLANS

TRENCH DRAIN

INDEX
436-001

SHEET
2 of 2

GENERAL NOTES

- The underdrain pipe shall be either 4" smooth or 5" corrugated tubing unless otherwise shown in the plans. The size to be furnished will be based on the nominal internal diameter of a pipe with a smooth interior wall. Except when prohibited by the plans, the special provisions or this standard, pipe with a corrugated interior wall may be provided based on the following size equivalency.

4" smooth interior equivalent to 5" corrugated interior
 5" smooth interior equivalent to 6" corrugated interior
 6" smooth interior equivalent to 8" corrugated interior
 8" smooth interior equivalent to 10" corrugated interior

- Fine aggregate shall be quartz sand meeting the requirements of Sections 902-4 of the Standard Specifications.
- Coarse aggregate shall be gravel or stone meeting the requirements of Sections 901-2 or 901-3. The gradation shall meet Section 901, Grades 4, 467, 5, 56 or 57 stone unless otherwise shown restricted in the plans.
- Underdrain Type I, II, III and V shall be in accordance with Section 440.
- Filter fabric shall be Type D-3 (See Specifications Section 985). The internal filter fabric of Type V underdrain shall have a permittivity of 0.7 /sec. and an AOS of #40 sieve.
- When Type I is used, a filter fabric sock meeting Section 948 is required.
- See Index 120-002 for the standard location of Type I, II, and III underdrain. The location of Type V underdrain and nonstandard locations of Type I, II, and III underdrain will be as detailed in the plans.
- All filter fabric joints shall overlap a minimum of 1'. The internal filter fabric of Type V underdrain shall overlap into the coarse aggregate or the fine aggregate a minimum of 1'.
- Underdrain outlet pipes shall be nonperforated and all bends shall be made using 1/8 (45 deg.) elbows. 90 deg. bends shall be constructed with two 1/8 elbows separated by at least 1' of straight pipe. Outlet pipes stubbed into inlets or other drainage structures shall be not less than 6" above the structure flow line. Outlet pipes discharging to grassed areas shall have concrete aprons, hardware cloth, and bordering sod as shown in Index 466-001 for Edgedrain outlets.
- Pay Item shall be based on the size of the smooth interior products. The contract unit price for Underdrain, LF, shall include the cost of pipe, fittings, aggregate, sock, filter fabric, underdrain cleanouts, and concrete aprons.

The contract unit price for Underdrain Outlet Pipe, LF, shall be full compensation for trench excavation, pipe and fittings, concrete aprons, hardware cloth for concrete aprons, stubbing into drainage structures, backfill in place, and disposal of excess materials.

The contract unit price for Underdrain Inspection Box, EA, shall be for the number completed and accepted.

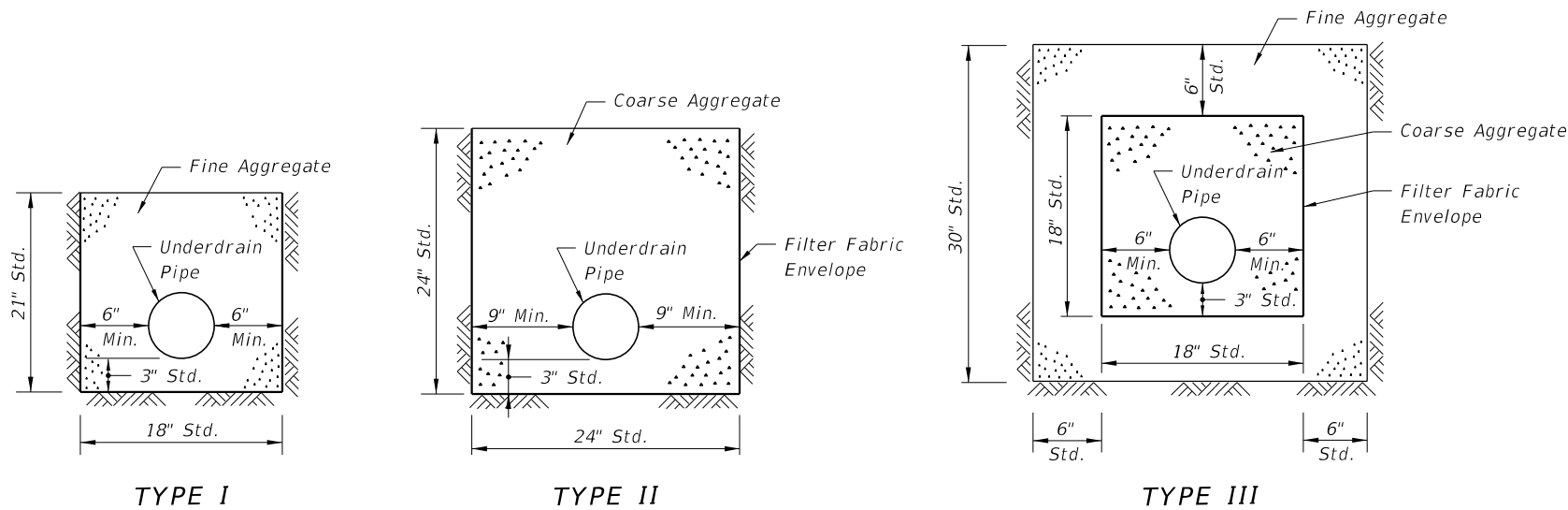

DESIGN NOTES

- The type of underdrain should be selected to meet design water removal rate and soil conditions. Caution is prescribed in the use of these typical sections since special designs may be required to satisfy project conditions.
- Type I underdrain is intended for minimum water removal conditions.
- Type II underdrain is intended for moderate water removal conditions. Where reactive conditions may create chemical clogging, the use of an inert material and/or elimination of the filter fabric may be necessary.
- Type III underdrain is intended for maximum water removal conditions. Filter fabric is required between the coarse aggregate or fine aggregate including those described in general notes 2 and 3. Design note 3 applies for reactive conditions.
- Type V underdrain is intended for use in detention basins and other locations which require a filtration system. The standard fine aggregate specified for Type V underdrain conforms to filtration gradation requirements of Chapter 62-25 FAC.
- The designer should detail in the plans, the location of:
 - Type V underdrain,
 - nonstandard locations of Type I, II, and III underdrain,
 - underdrain inspection boxes,
 - cleanouts for Type V underdrain, and
 - underdrain outlet pipes.
- The designer should specify the flow line elevations at the beginning, bends, junctions and ends of underdrain pipes and outlet pipes.
- The designer should evaluate whether an external filter fabric envelope is required around underdrain Types I and III. When required, fabric shall be specified in the plans.

10/30/2018 8:49:25 AM

LAST REVISION 11/01/17	REVISION	DESCRIPTION:	 FY 2019-20 STANDARD PLANS	UNDERDRAIN	INDEX 440-001	SHEET 1 of 2
---------------------------	----------	--------------	----------------------------------	------------	------------------	-----------------

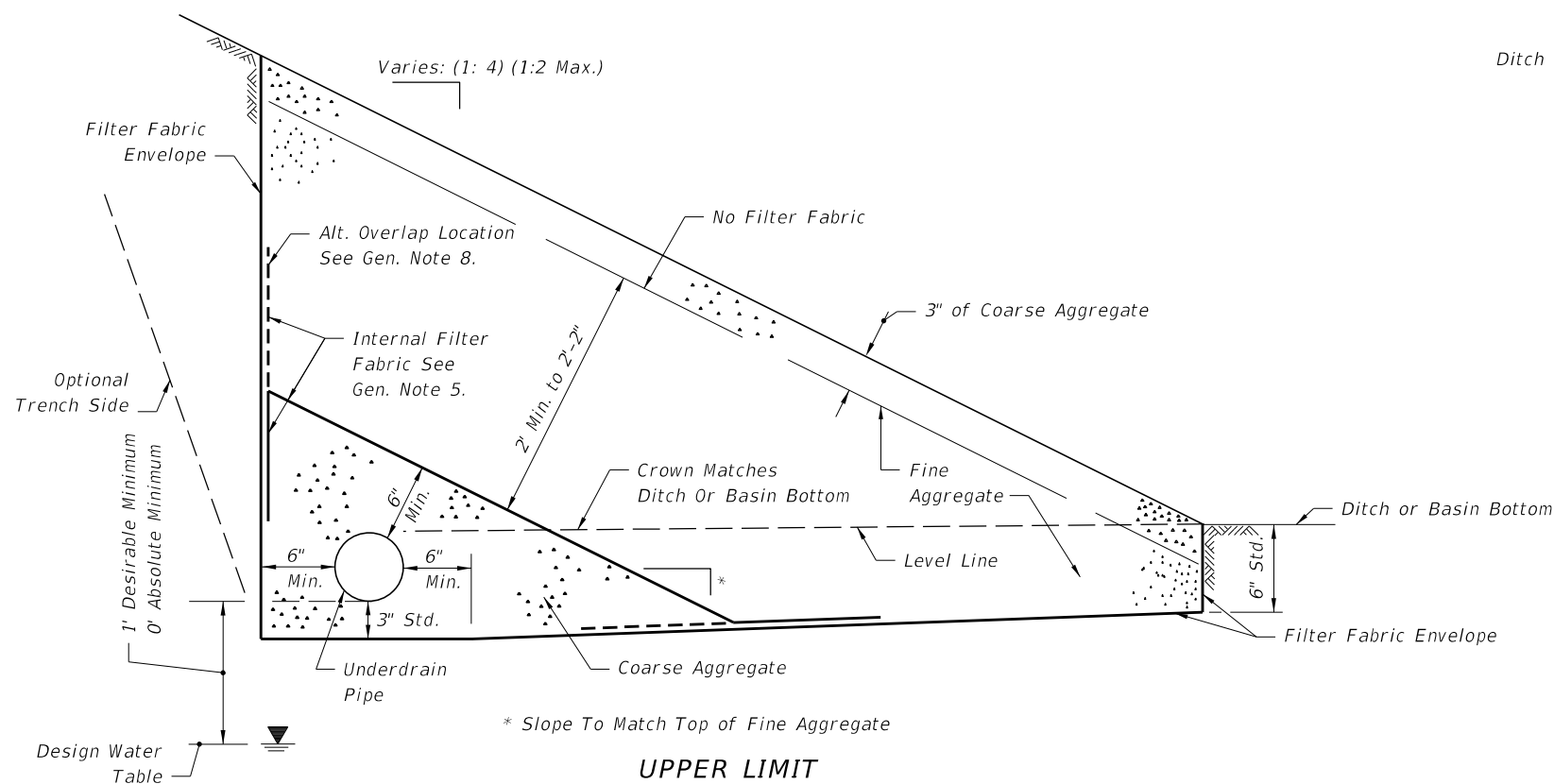

UPPER LIMIT

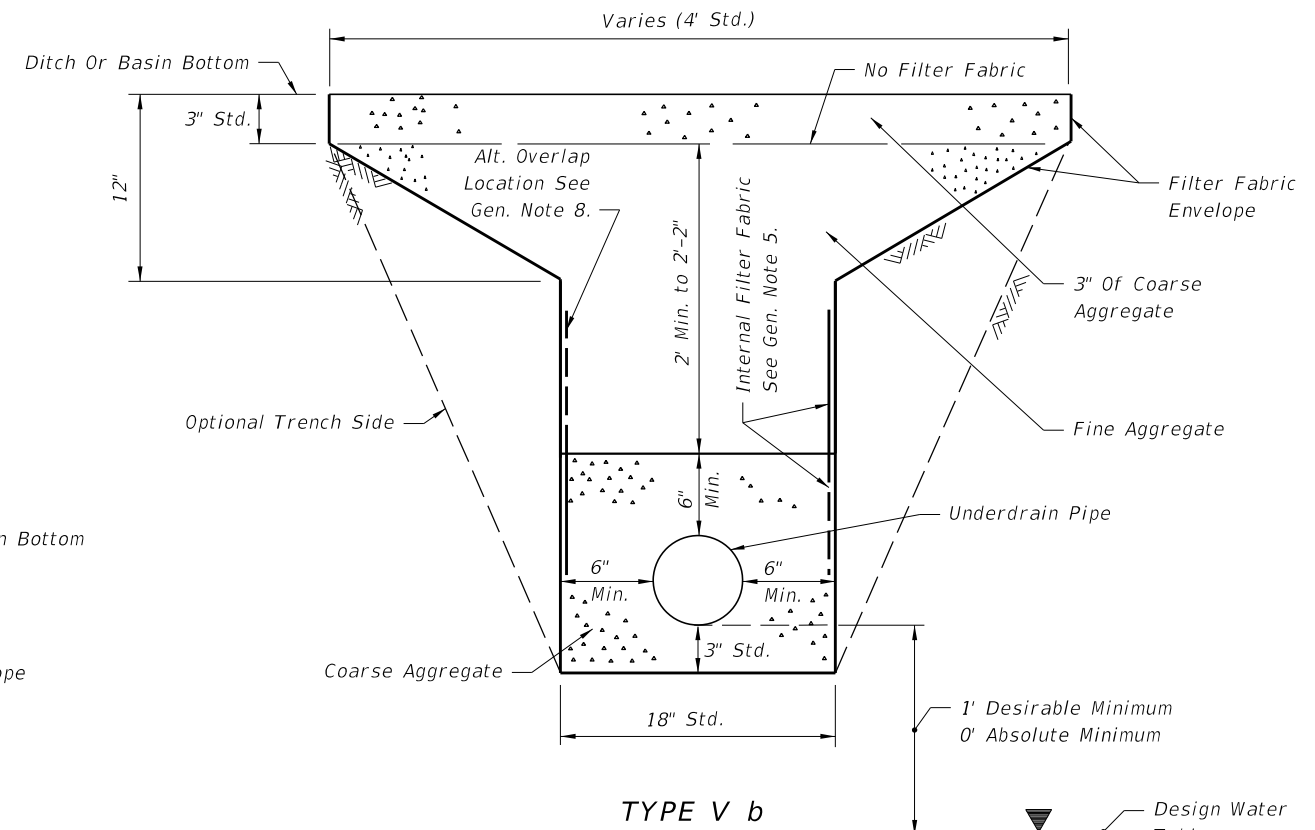

TYPE V b

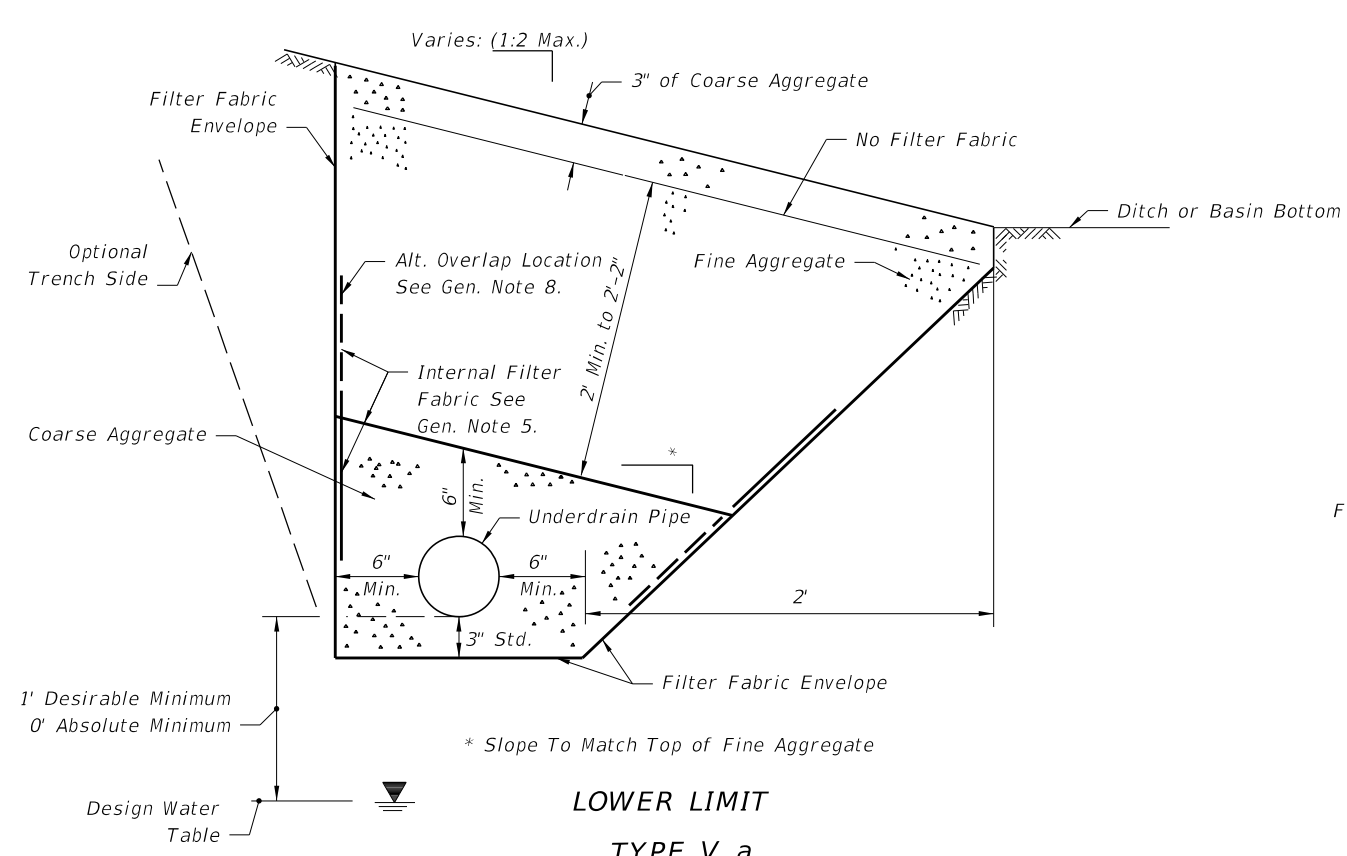

LOWER LIMIT
TYPE V a

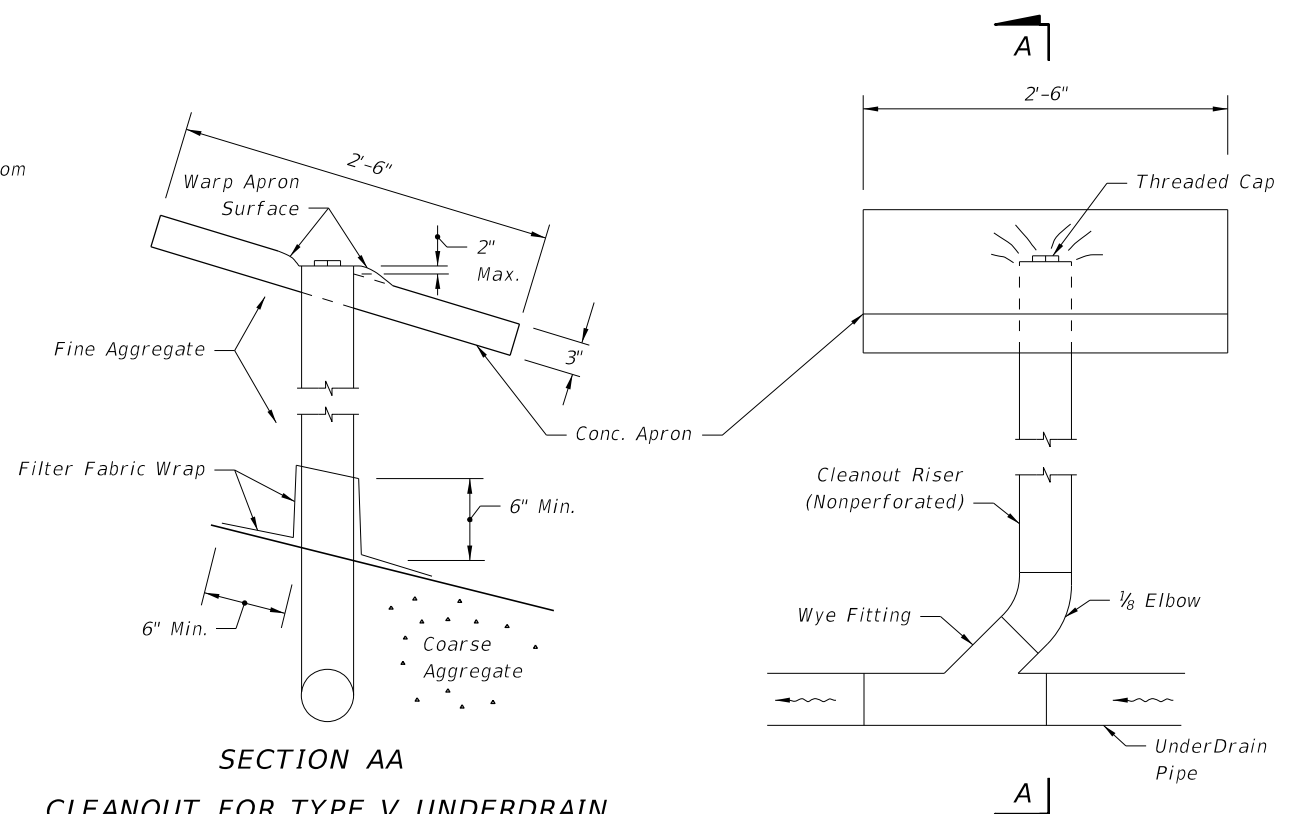

SECTION AA
CLEANOUT FOR TYPE V UNDERDRAIN

10/30/2018 8:49:29 AM

LAST REVISION 11/01/17	REVISION	DESCRIPTION:	 FY 2019-20 STANDARD PLANS	UNDERDRAIN	INDEX 440-001	SHEET 2 of 2
---------------------------	----------	--------------	-------------------------------------------------------------------------------------------------------------------	------------	------------------	-----------------

10/30/2018 8:49:32 AM

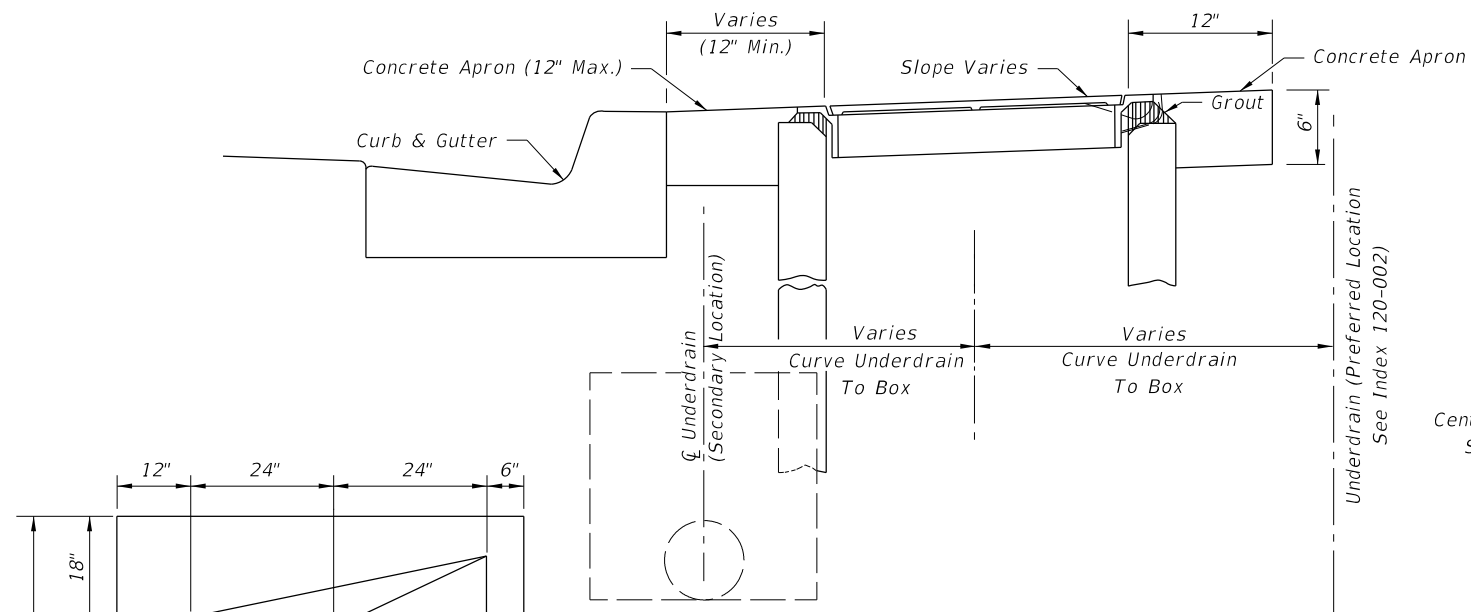

TYPICAL URBAN INSTALLATION

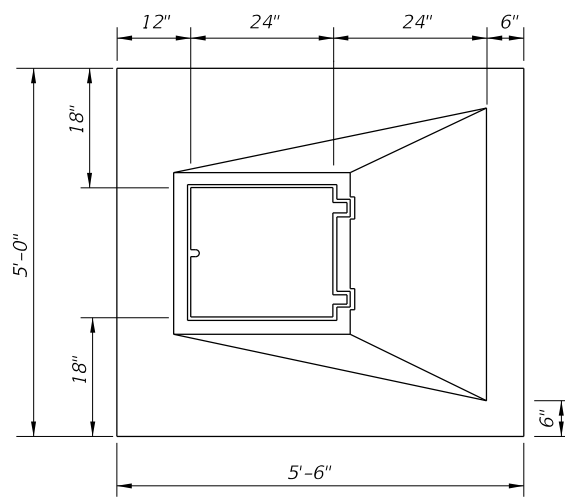

TOP VIEW

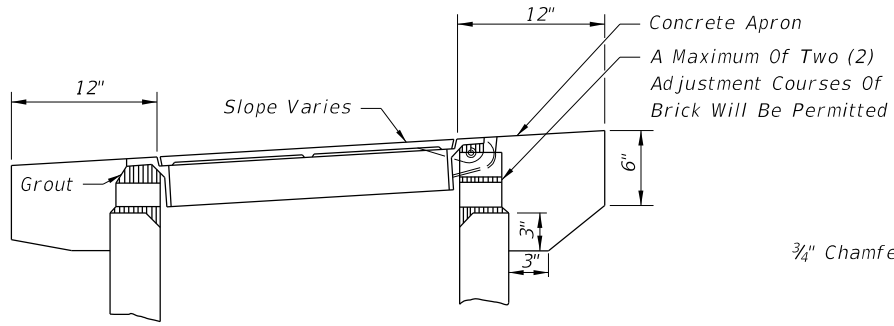

PERMISSIBLE TOP ADJUSTMENT

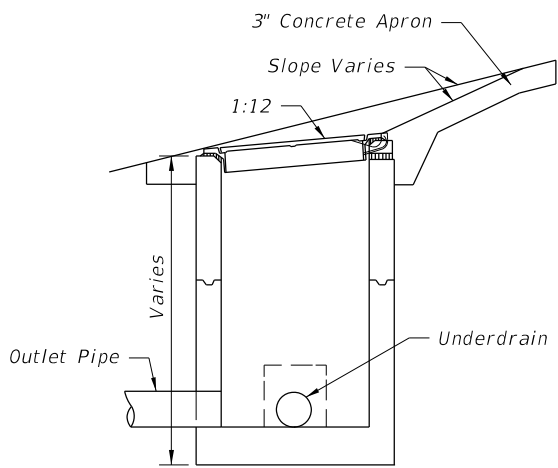

**SECTION
TYPICAL INSTALLATION ON SLOPES**

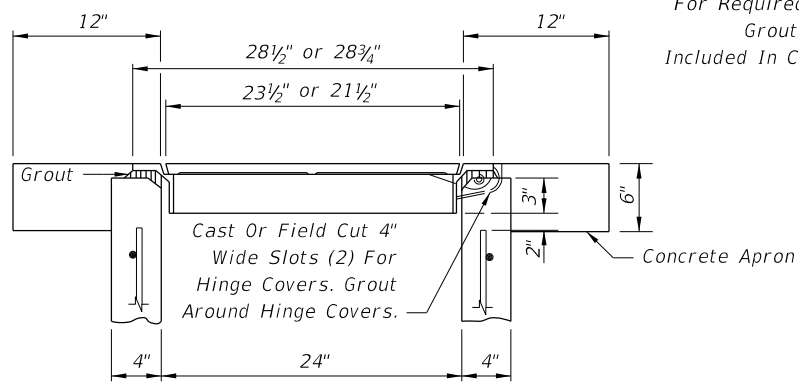

TYPICAL TOP AND APRON

Typical Opening, One Or More Sides. See Plans For Required Openings. Grout Fill To Be Included In Cost Of Box

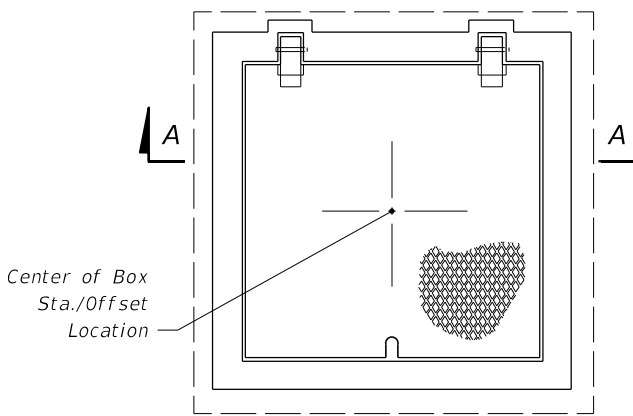

TOP VIEW

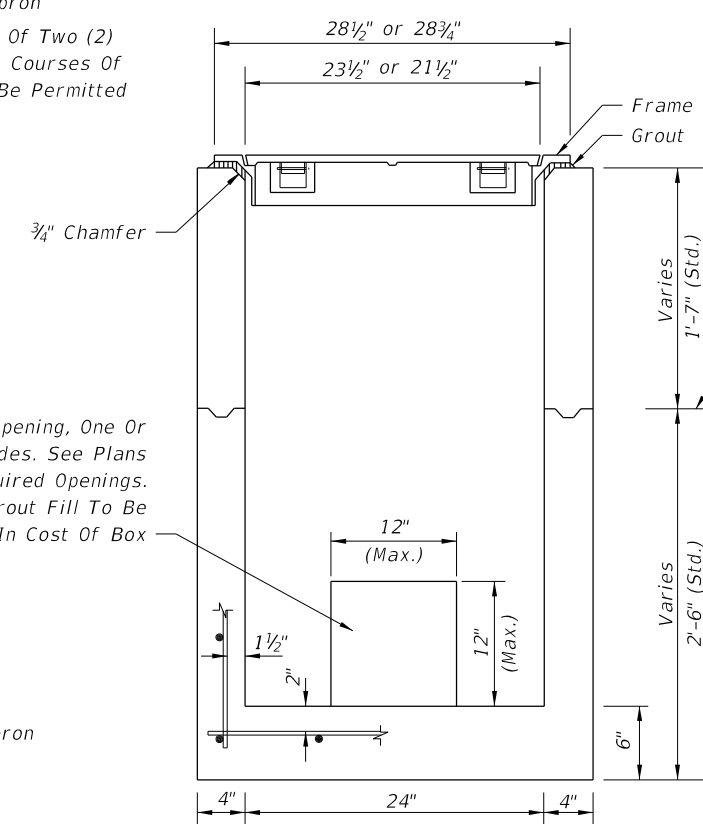

**SECTION AA
BOX AND TOP**

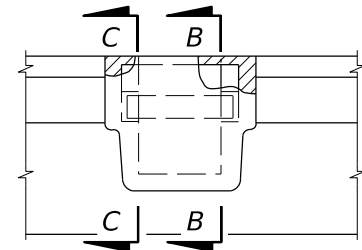

BACK VIEW

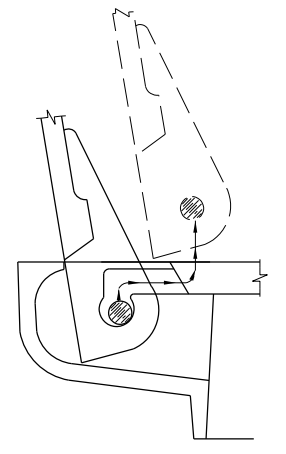

COVER REMOVAL

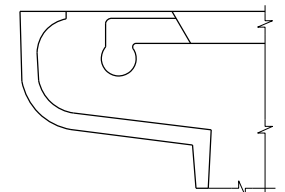

SECTION CC

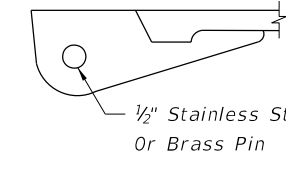

SECTION BB

HINGE DETAIL

GENERAL NOTES

1. Light duty cast iron cover and frame, see Specifications Section 962.
2. Concrete shall be Class I, except ASTM C478 (4000 psi) concrete may be substituted for precast items manufactured in plants meeting the requirements of Section 449 of the Specifications. Box shall be reinforced with No. 3 bars (Grade 60) on 8" centers both ways, sides and bottom.
3. Concrete apron to be included in the contract unit price for Underdrain Inspection Box.
4. All covers shall be furnished with pick holes. Fitted lifts or handles are not permitted.
5. Manhole Type P Alternate A, Index 425-010, with Type I Frame and Cover, Index 425-001, may be used in lieu of the box detailed on this sheet, and is recommended when high ADT increases chance of the repeated vehicle loadings.

LAST REVISION
11/01/17

DESCRIPTION:



FY 2019-20
STANDARD PLANS

UNDERDRAIN INSPECTION BOX

INDEX
440-002

SHEET
1 of 1

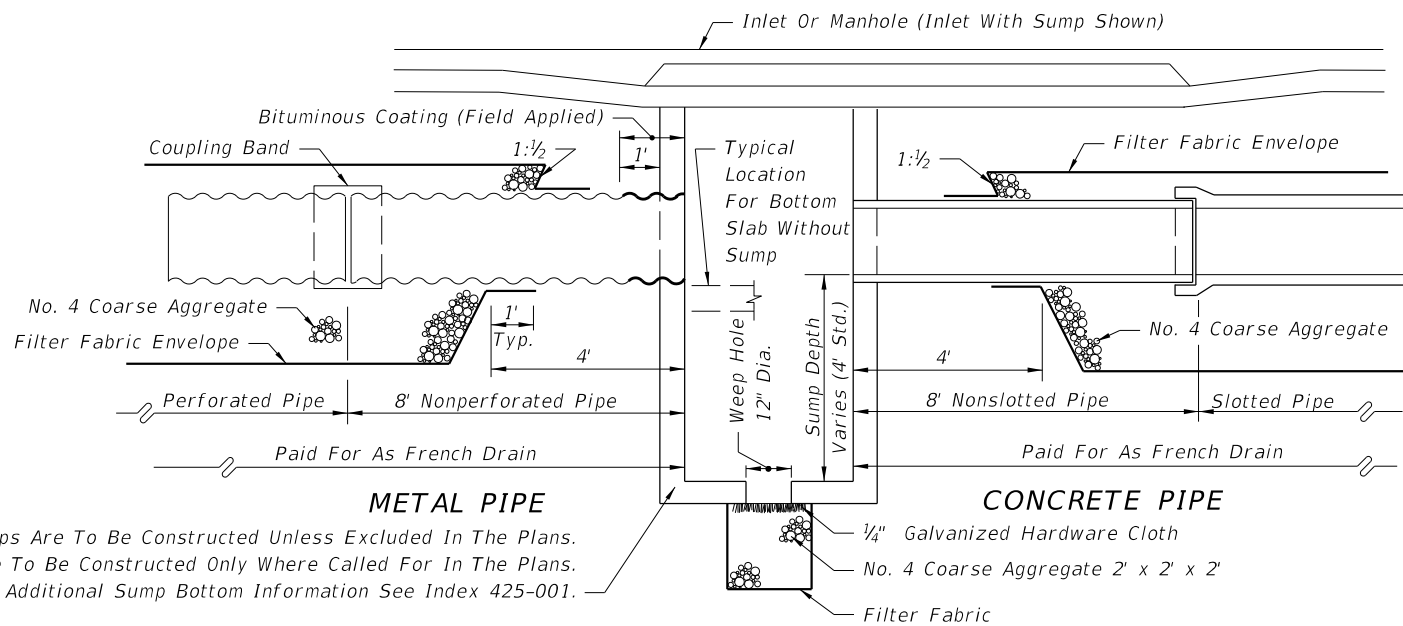

Sumps Are To Be Constructed Unless Excluded In The Plans.
 Weep Hole To Be Constructed Only Where Called For In The Plans.
 For Additional Sump Bottom Information See Index 425-001.

LONGITUDINAL SECTION

GENERAL NOTES

1. Pipe shall be any of the optional types permitted in Section 443 of the Specifications unless otherwise restricted in the plans. Dissimilar types of pipe will not be permitted in a continuous run of pipe.
2. Concrete pipe shall be placed with the slots positioned on sides.
3. Alignment joints are standard (gaskets not required). Recorrugation of metal pipe ends not required.
4. The contractor may submit other methods of providing slots having equal or greater area of opening, for approval by the Engineer.
5. Filter fabric shall be Type D-3 meeting the requirements of Section 985. All filter fabric joints shall lap a minimum of one (1) foot.
6. The standard cross section shall be constructed unless other section(s) described or detailed in the plans.
7. For supplemental details see Index 430-001.
8. The contractor shall take the necessary precautions to prevent contamination of the trench with sand, silt and foreign materials.
9. French drains shall be paid for under the contract unit price for French Drains, LF. The unit price shall include the cost of pipe, pipe plugs, pipe fittings, coarse aggregate and filter fabric in place, and the cost for trench excavation, backfill and compaction. The unit price shall also include the cost for disposal of surplus excavated materials and cost for restoration of pavement removed or damaged by french drain construction, but shall not include payments for items paid for elsewhere.

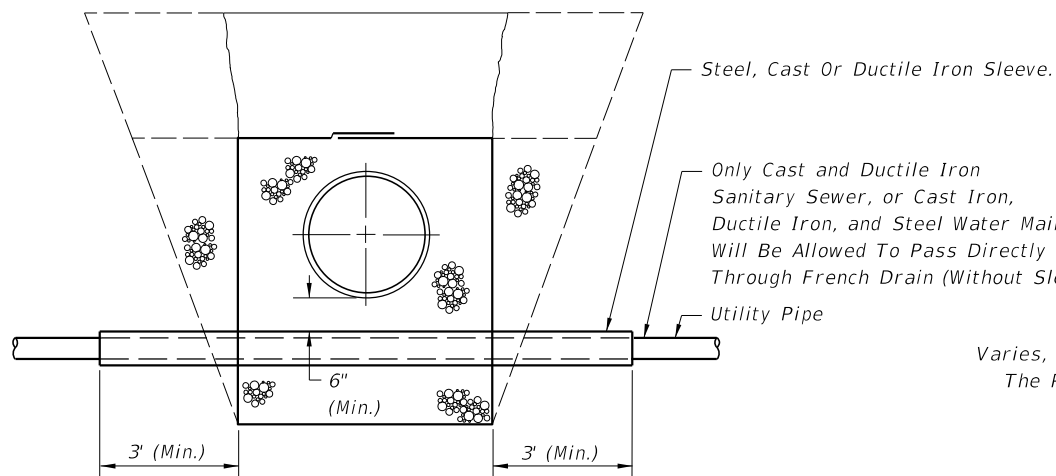

ROUND PIPE SHOWN
 UTILITY PIPES THRU FRENCH DRAIN

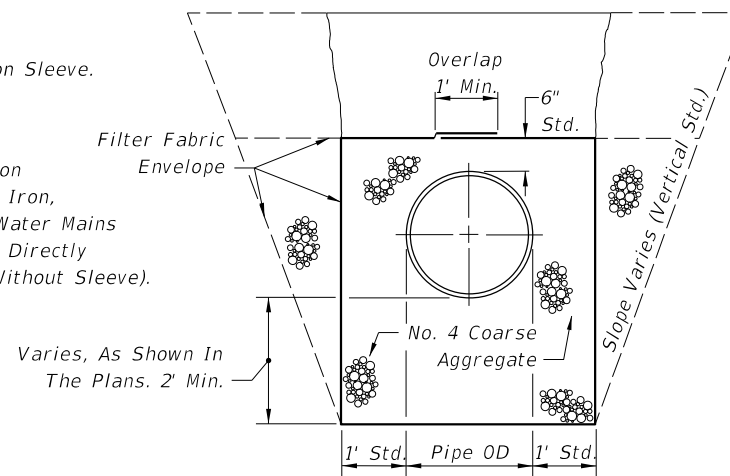

ROUND PIPE SHOWN
 STANDARD CROSS SECTION (ENLARGED)

FRENCH DRAIN SYSTEM

DESIGN NOTES

1. Pipe invert should be at or above the water table whenever possible.
2. French drains with minor dimensional changes or otherwise different from the standard cross-section shall be either described or detailed in the plans. French drains with significantly different cross-sections shall be detailed in the plans.

10/30/2018 8:49:35 AM

LAST REVISION 11/01/17	REVISION	DESCRIPTION:	 FY 2019-20 STANDARD PLANS	FRENCH DRAIN	INDEX 443-001	SHEET 1 of 2
---------------------------	----------	--------------	-----------------------------------------------------------------------------------------------------------------------	---------------------	-------------------------	------------------------

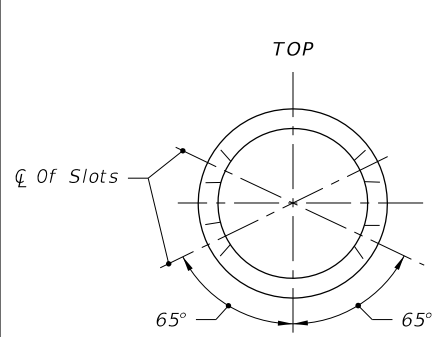

15"-30"

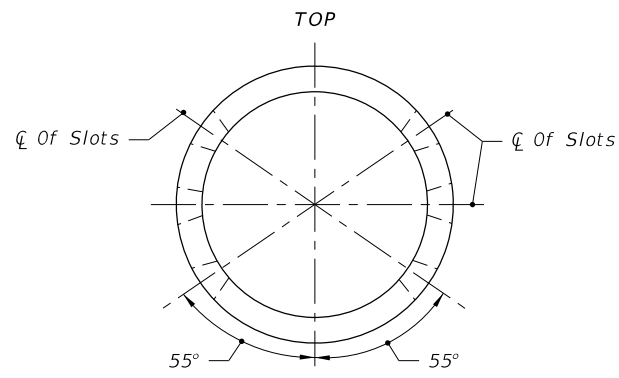

36"-72"

ELLIPTICAL PIPE		
Pipe Size	Slot Cut	
	Opening c	
	Min.	Max.
14"x23"	10"	12"
19"x30"	14"	16"
24"x38"	14"	16"
29"x45"	20"	22"
34"x53"	20"	22"
38"x60"	20"	22"

ROUND PIPE		
Pipe Size	Slot Cut	
	Opening c	
	Min.	Max.
15"	12"	14"
18"	12"	14"
24"	16"	18"
30"	16"	18"
36"	22"	24"
42"	22"	24"
48"	22"	24"
54"	24"	26"
60"	24"	26"
66"	24"	26"
72"	24"	26"

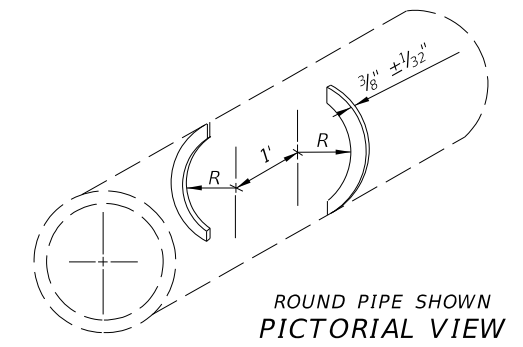

ROUND PIPE SHOWN PICTORIAL VIEW

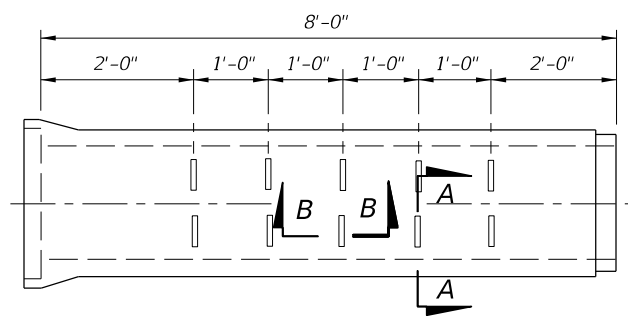

SIDE VIEW

OPTION A - ROUND PIPE

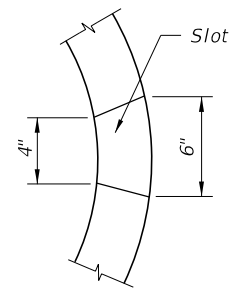

SECTION AA

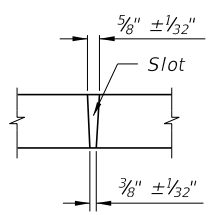

SECTION BB

A curved cut is acceptable provided the control dimension is maintained (Typical For Elliptical & Round Pipe)

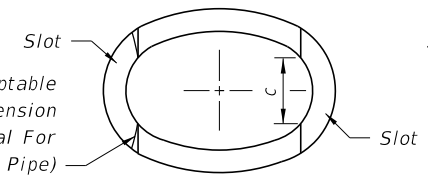

ELLIPTICAL PIPE SECTION AA

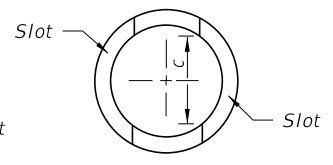

ROUND PIPE SECTION AA

OPTION B - ROUND OR ELLIPTICAL PIPE

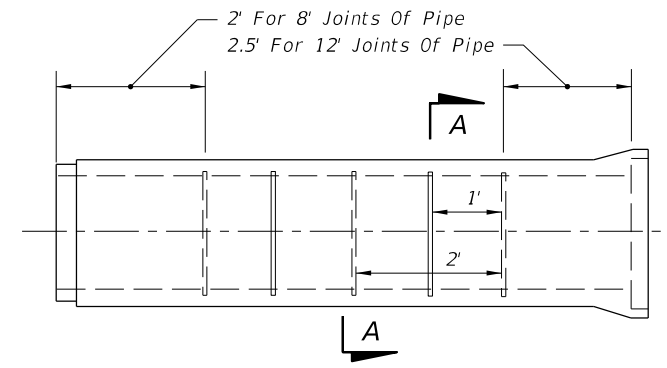

SIDE VIEW

SLOTTED PIPE OPTIONS

10/30/2018 8:49:40 AM

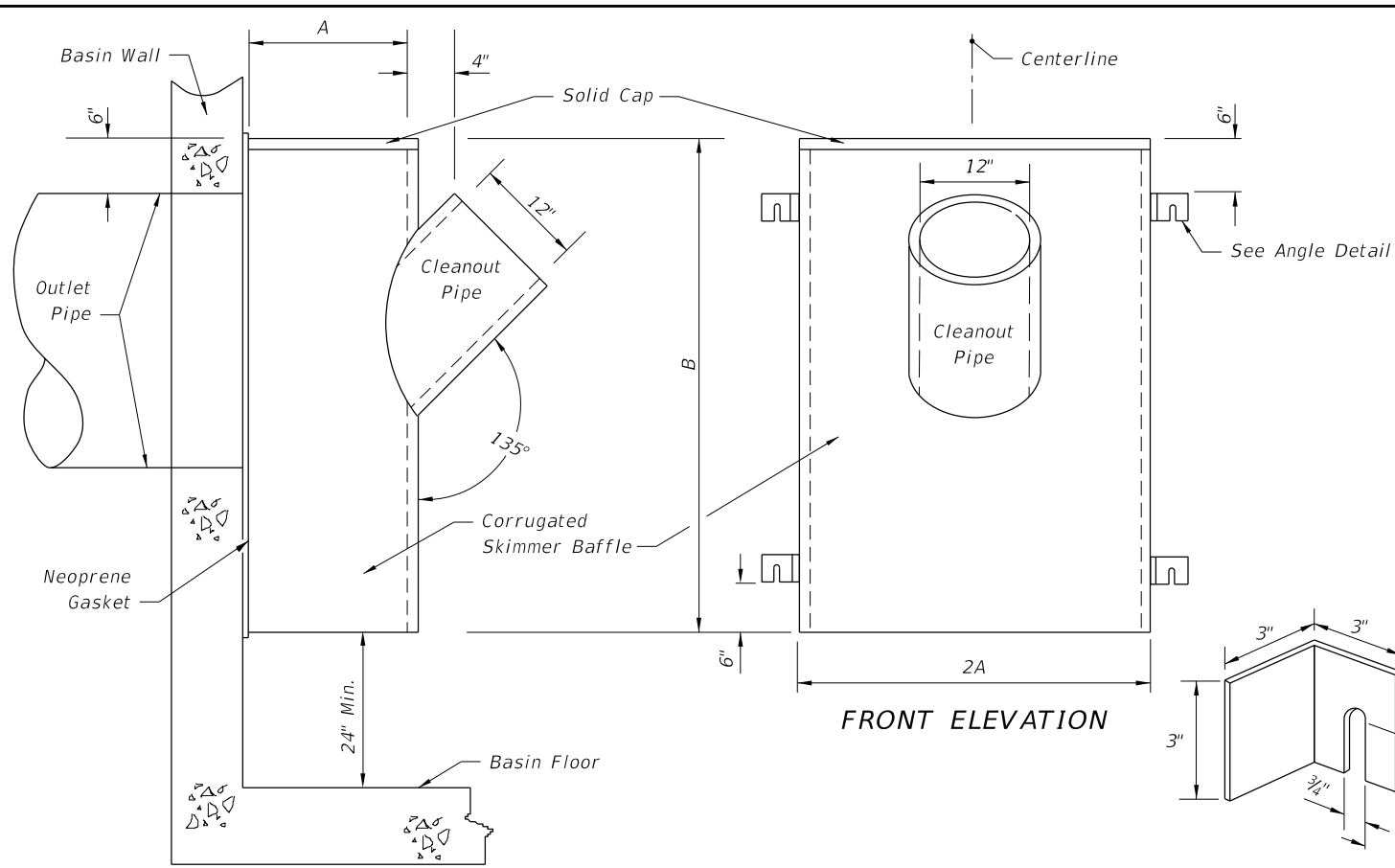

SIDE ELEVATION

FRONT ELEVATION

ANGLE DETAIL

TYPE I SKIMMER

Angles on other side of skimmer are mirror image.

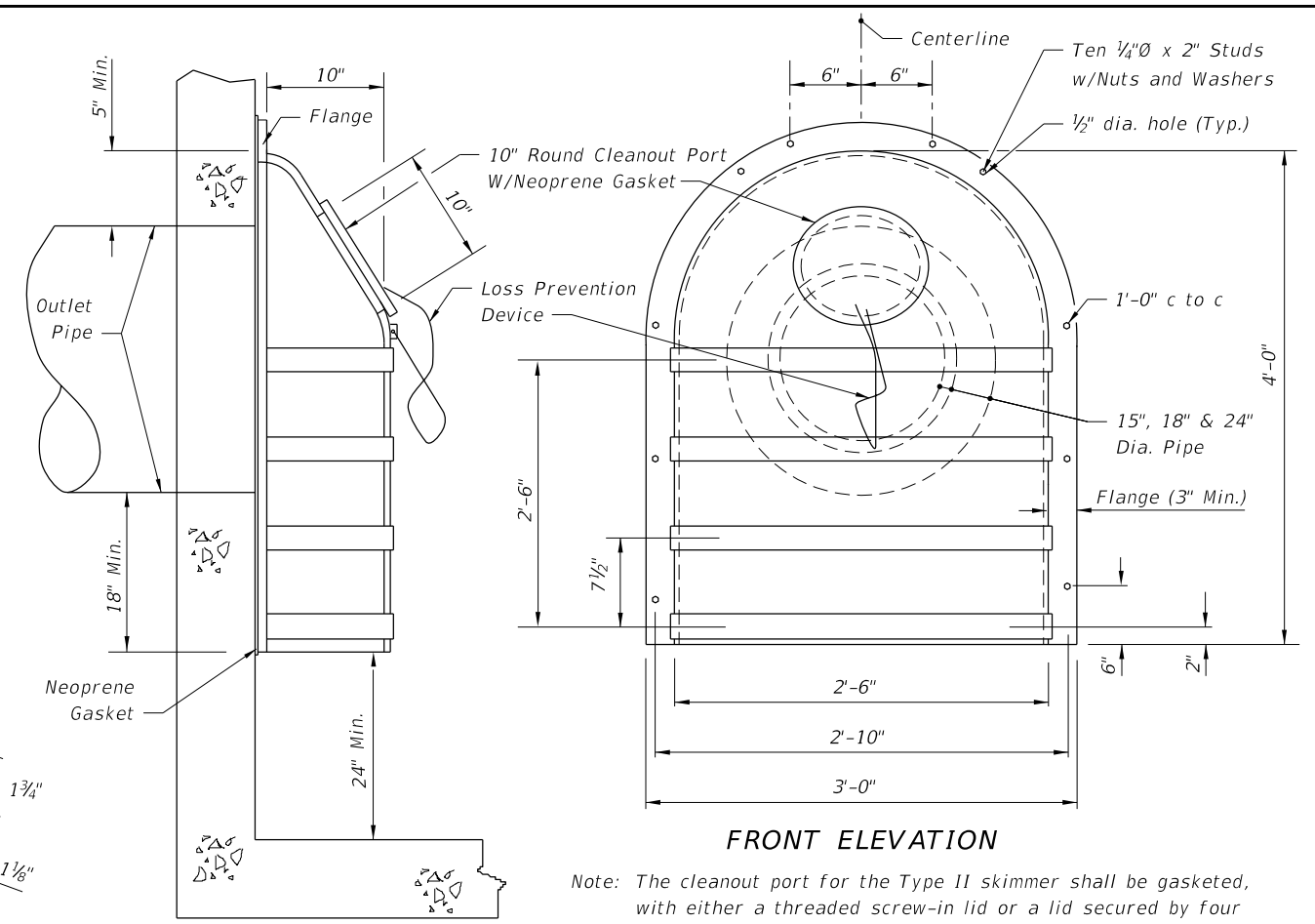

SIDE ELEVATION

FRONT ELEVATION

TYPE II SKIMMER

Note: The cleanout port for the Type II skimmer shall be gasketed, with either a threaded screw-in lid or a lid secured by four stainless steel quick-release latches.

GENERAL NOTES

1. The Frenchdrain Skimmer is a hooded cover, mounted over an outlet in a catchbasin, that prevents oil and floating debris from exiting the basin. Use this skimmer in Frenchdrain Catchbasins and in other locations where there is a need to prevent oil, debris or other floating contaminants from exiting Catchbasins through outlet pipes.
2. Place neoprene gasket material between the skimmer and the catchbasin at all points of contact. Trim the gasket neatly to extend 1/2 inch beyond the joint on all sides.
3. Skimmer baffle, cleanout pipe and angles shall be primarily constructed of either galvanized steel, aluminum, polyvinyl chloride, polyethylene, fiberglass or acrylonitrile butadiene styrene. All steel components, other than stainless, shall be hot-dip galvanized.
4. Mounting hardware, hinges and latches shall all be stainless steel. Loss prevention device shall be either stainless steel chain or riveted nylon strap.
5. Material used in construction of skimmer bodies (baffles) and cleanout pipe shall comply with Standard Specification 943 for steel, 945 for aluminum or 948 for plastics.
6. All costs for furnishing and installing a frenchdrain skimmer shall be included in the cost of the basin in which it is installed. Retrofit skimmers shall be paid for as 'modify existing structure'.
7. Plastic Skimmers shall contain a minimum of 1.5% by weight of carbon black for UV protection.

DESIGN NOTES

1. The contractor may submit an alternative design prefabricated Frenchdrain Skimmer for approval by the Engineer.
2. Show, in the plans, the location of the basin and indicate the interior side(s) of the basin on which a skimmer will be installed.
3. Type I Skimmer dimensions shall be based on the outlet pipe diameter as shown in the dimension table.
4. Type II Skimmers are to be used only with outlet pipe diameters of 15", 18", and 24".

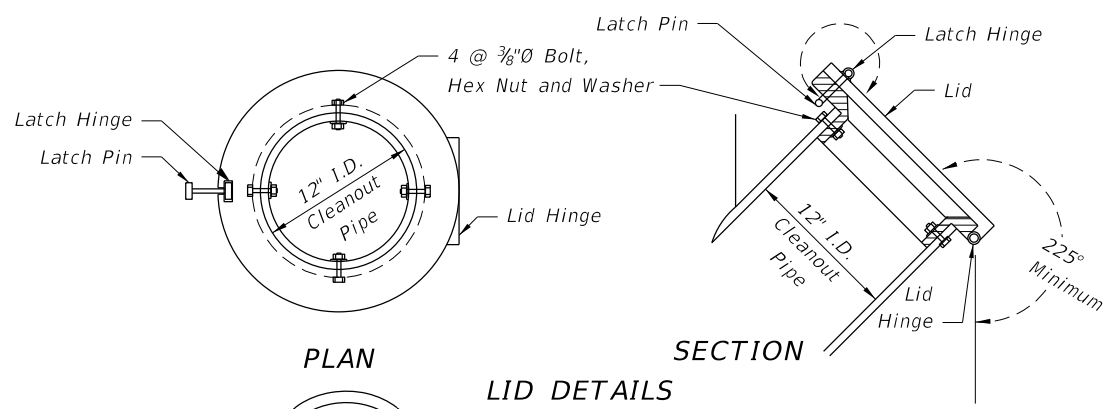

PLAN

SECTION

LID DETAILS

TYPE I SKIMMER DIMENSION TABLE		
OUTLET PIPE	A	B
18"	12"	42"
24"	15"	48"
30"	18"	54"
36"	21"	60"

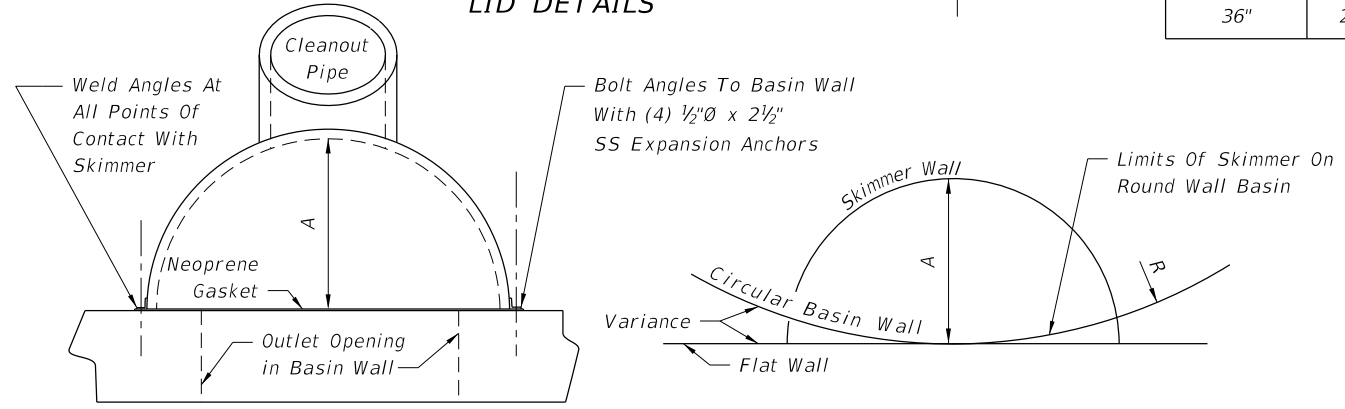

TOP VIEW

TOP VIEW SCHEMATIC

The backs of skimmers must conform to the shape of the basin walls on which they are mounted. Show, in the plans, the radii required for curved-back skimmers. Applies to both skimmer types.

10/30/2018 8:49:43 AM

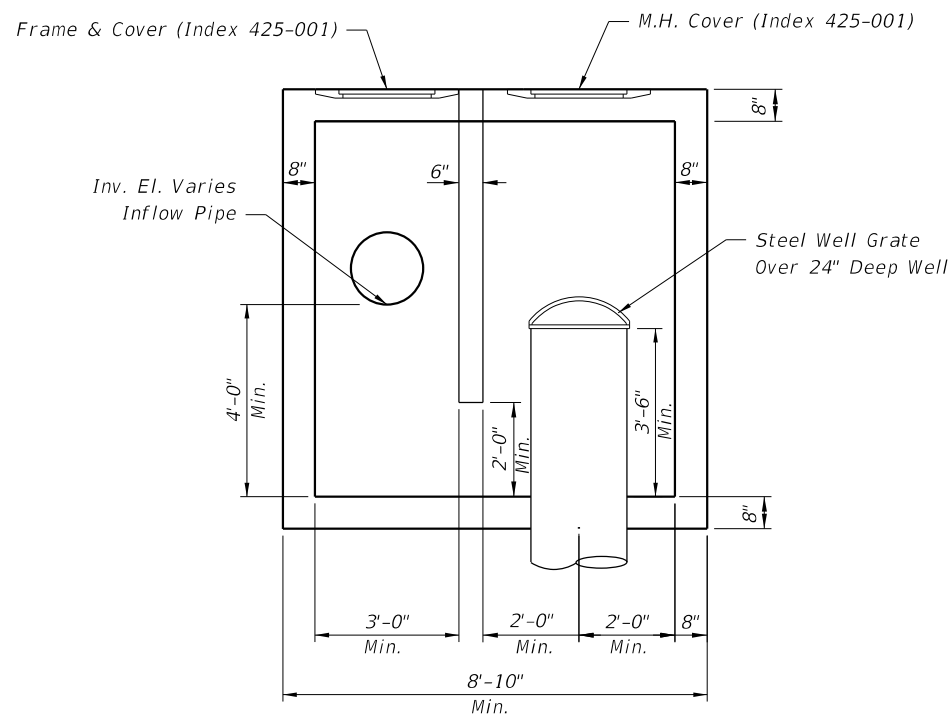
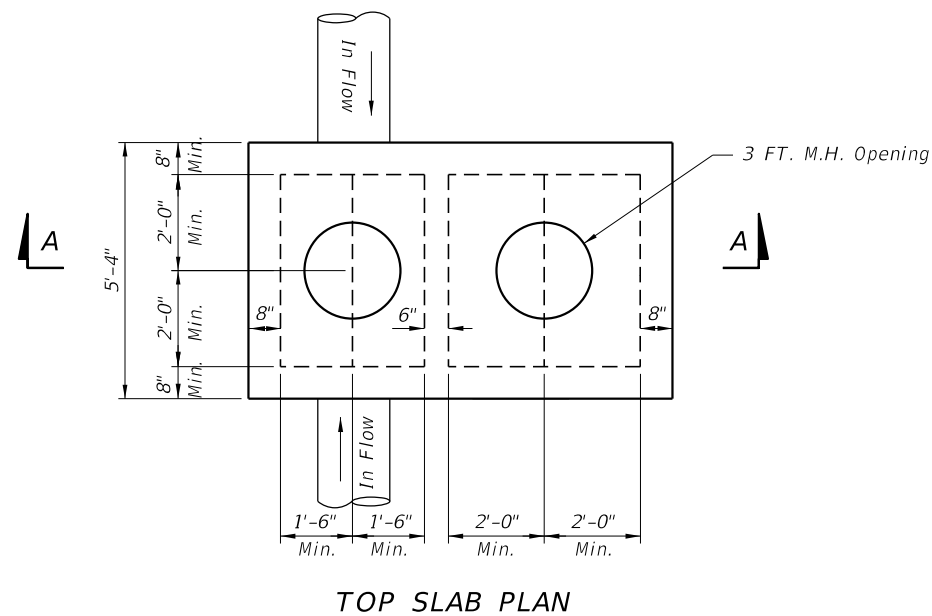

STRUCTURE WITH NO OUTFLOW

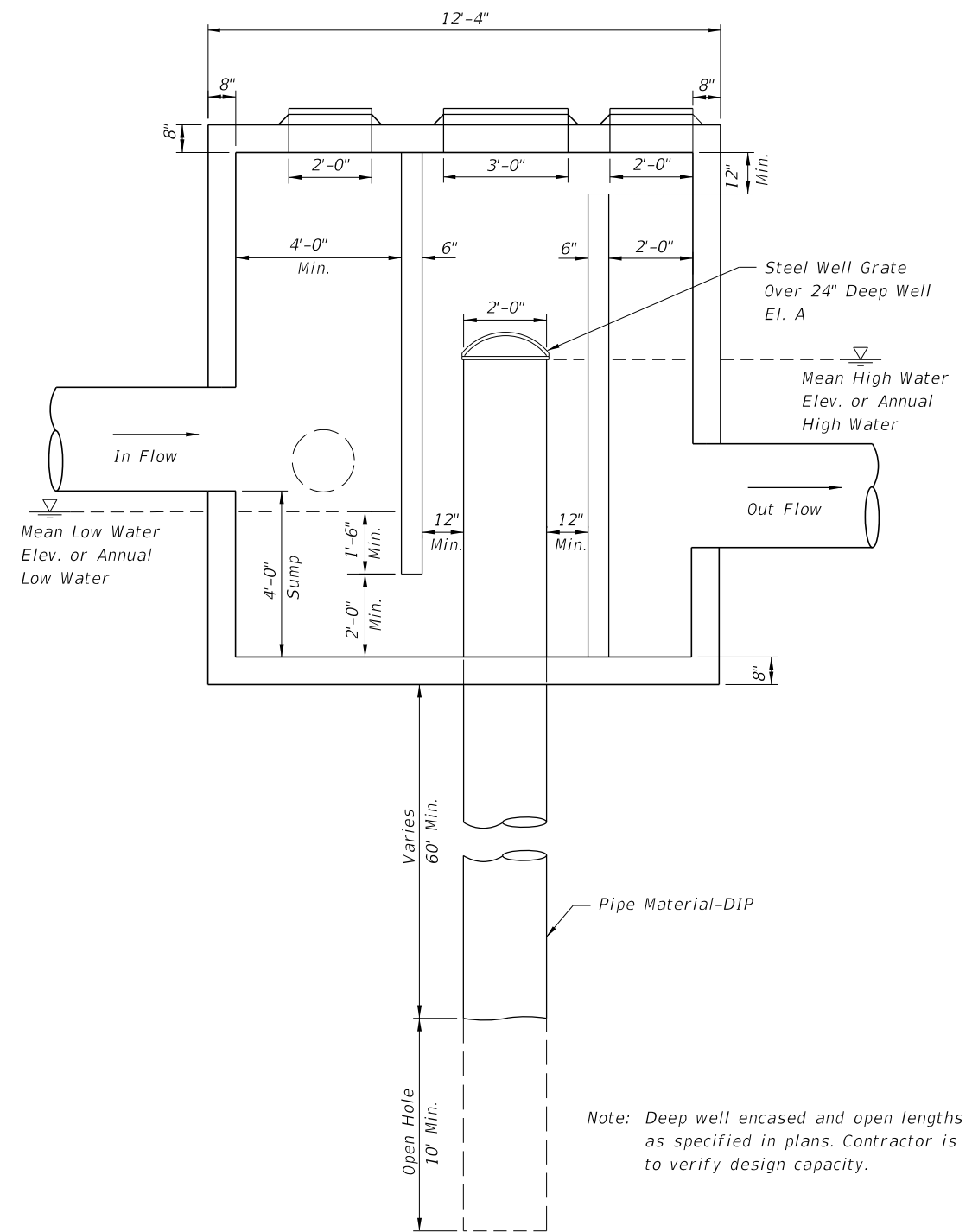

Note: Deep well encased and open lengths as specified in plans. Contractor is to verify design capacity.

SPECIAL MANHOLE STRUCTURE DETAIL WITH OUTFALL

DESIGN NOTES:

1. Depth of Casing Varies, 60' min.
2. Depth of Open Hole, 10'-20'.
3. Actual Size Of The Inflow And Outflow Chambers Will Be Determined By The Size Of The Pipes (Refer To Table 3 Of Index 425-010). The Width Of The Box Shall Be Constant Based On The Largest Pipe. The Length Is To Be Adjusted Based On Size and Orientation Of The Pipes.

24" STEEL WELL GRATE

Heavy duty "bee hive" grate

Openings: 1-1/2" maximum

Total Opening: 1.7 sq ft minimum

For 24" well, outer diameter = 29"

Steel well grate to be installed over 24" deep well.

Steel grate to be hot dipped galvanized after fabrication, see Specification Section 962.

10/30/2018 8:49:48 AM

LAST REVISION 11/01/17	REVISION	DESCRIPTION:	 FY 2019-20 STANDARD PLANS	DEEP WELL INJECTION BOX	INDEX 444-T01	SHEET 1 of 1
---------------------------	----------	--------------	-------------------------------------------------------------------------------------------------------------------------------	--------------------------------	-------------------------	------------------------

SHEET PILE DESIGN CRITERIA AND NOTES

DESCRIPTION:
 This Index includes details for five types of piles with two thicknesses. Types "B1", "B2", "C1" and "C2" piles (corner piles) are of reinforced concrete construction, and Type "A" is of prestressed concrete construction. The piles shall be manufactured, cured and installed in accordance with the requirements of the contract documents.

MATERIALS: (for materials not listed refer to the Specifications)
CONCRETE
 Class: V (Special) for slightly and moderately aggressive environments
 V (Special) with silica fume, metakaolin or ultrafine fly ash for extremely aggressive environments
 Unit weight: 150 pcf
 Modulus of Elasticity: Based on the use of Florida limerock concrete

REINFORCING STEEL
 ASTM A615 Grade 60

PRESTRESSING STEEL
 ASTM A416 Grade 270 (Low-Relaxation Strand)

DESIGN PARAMETERS:
 Type "A"
 Concrete Compressive Strength at release of prestressing: 4000 psi minimum
 Uniform compression after prestressing losses: 1000 psi minimum
 Pick-up, Storage and Transportation: 0.0 psi tension with 1.5 times pile self weight
 Types "B1", "B2", "C1" & "C2"
 Pick-up, Storage and Transportation: Minimum compressive strength $f'_{ci} \geq 4000$ psi required.

ENVIRONMENT:
 The pile designs are applicable to all Environments.

PLASTIC FILTER FABRIC:
 The plastic filter fabric shall extend to the bottom of the "X" dimension.

PILE PICK-UP AND HANDLING:
 Type "A"
 Pick-up of pile may be either a single point pick-up or a two point pick-up as shown below.
 Types "B1", "B2", "C1" & "C2"
 Two point pick-up for lifting out of forms & two point support for storage & transportation.
 Single point pick-up for installation only.

PILE FIT-UP:
 The 2'-6" Sheet Pile dimension is nominal. This dimension may be shortened by the Manufacturer up to 1/2" to allow for Sheet Pile fit-up in its final position. Minimum Sheet Pile width is 2'-5 1/2". No changes shall be made to the tongues or grooves.

CROSS REFERENCES:
 For Dimensions L and X see Sheet Pile Wall Data Table in Structures Plans.

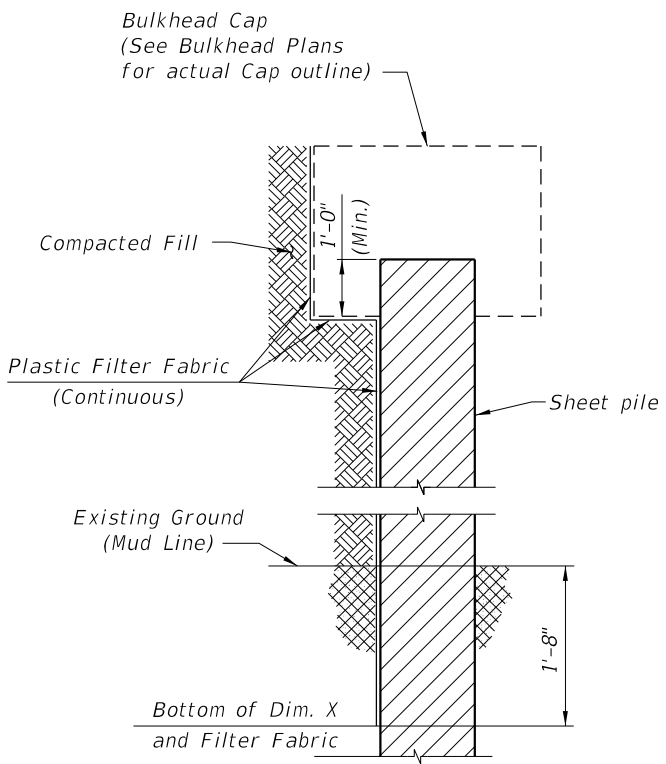

SECTION THRU BULKHEAD
 (Showing Plastic Filter Fabric)

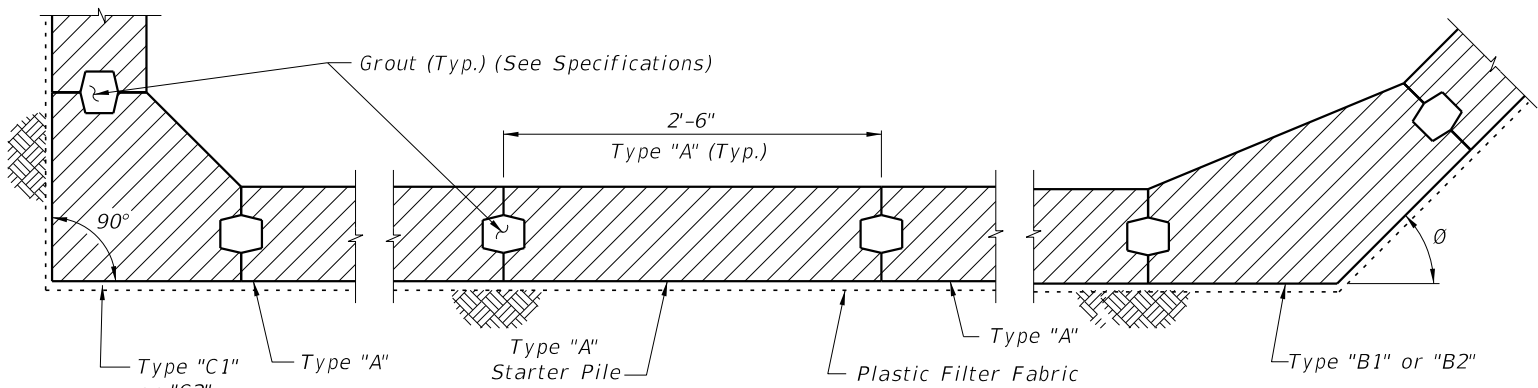

DETAIL "A"
 (Cap and Anchoring System Not Shown)
 (Section Taken Above Dimension X)

NOTE: Detail "A" shows a Part-Plan View of an assumed bulkhead. See Bulkhead plans for actual Plan View.

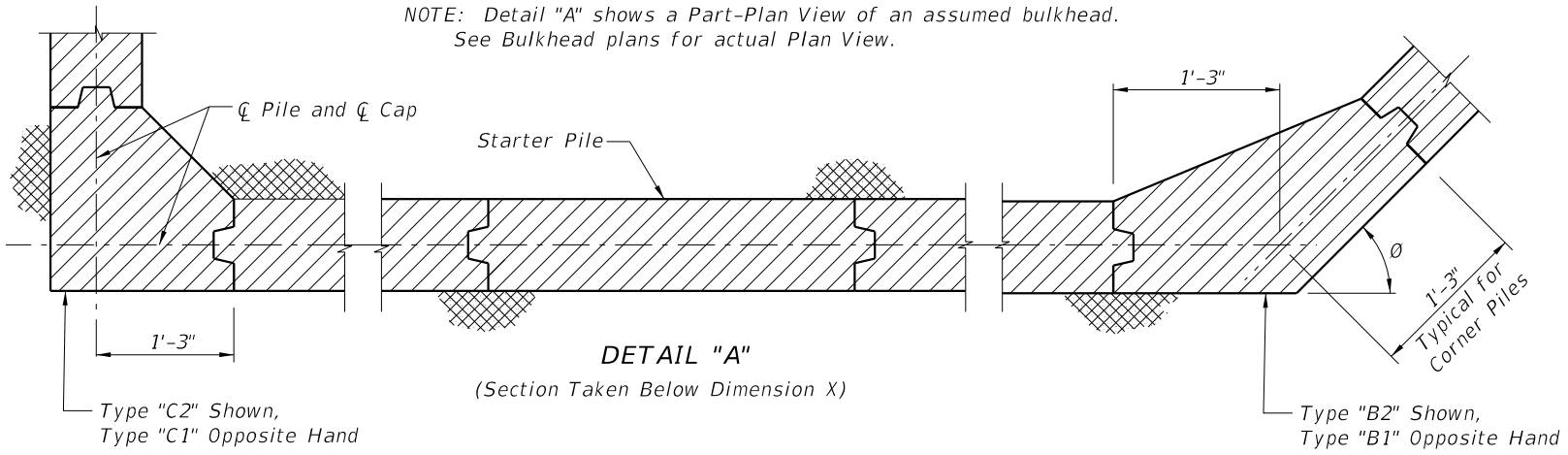

DETAIL "A"
 (Section Taken Below Dimension X)

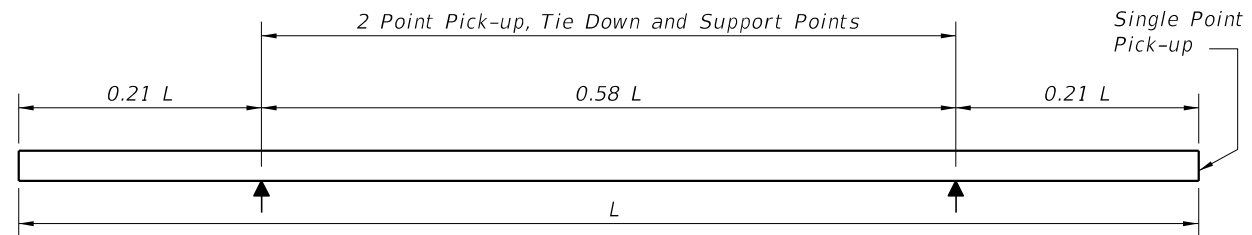

PILE STORAGE AND TRANSPORTATION SUPPORT DETAILS

NOTES AND DETAILS

LAST REVISION 11/01/17	DESCRIPTION:	 FY 2019-20 STANDARD PLANS	PRECAST CONCRETE SHEET PILE WALL (CONVENTIONAL)	INDEX 455-400	SHEET 1 of 4
---------------------------	--------------	----------------------------------------------------------------------------------------------------------------------	----------------------------------------------------	------------------	-----------------

SDATES

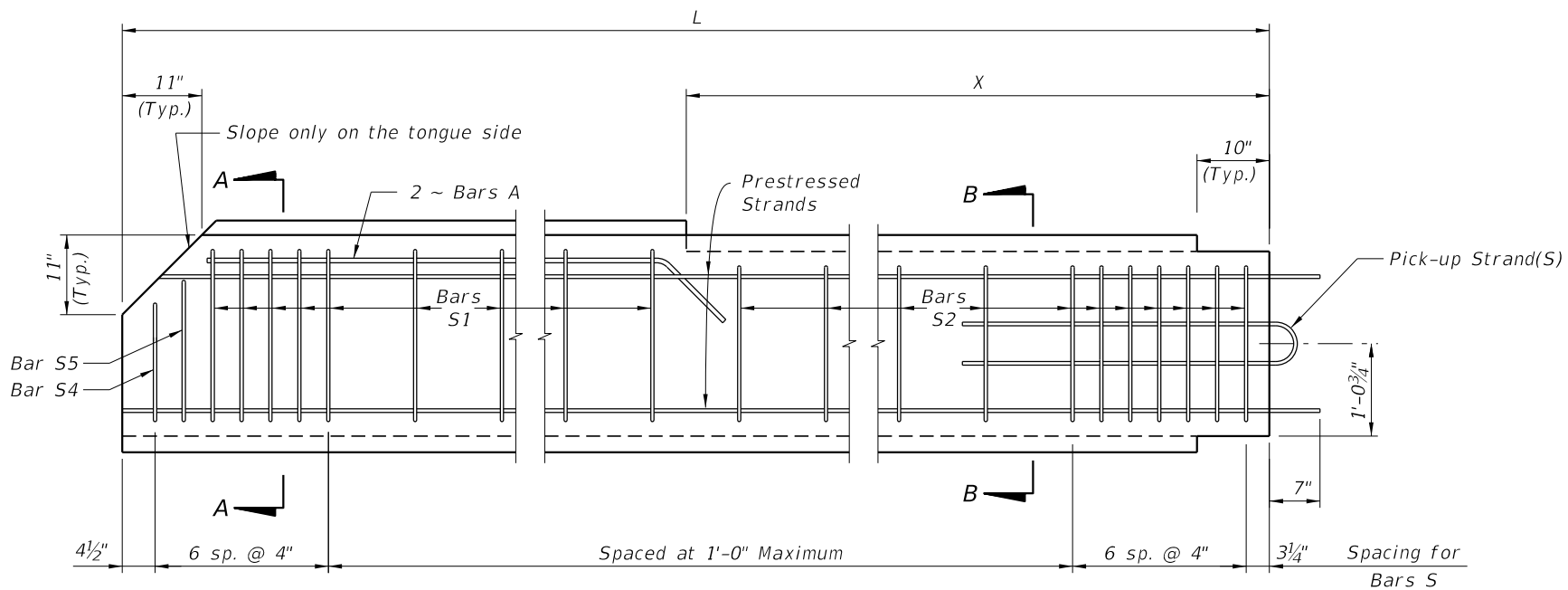

TYPICAL PILE

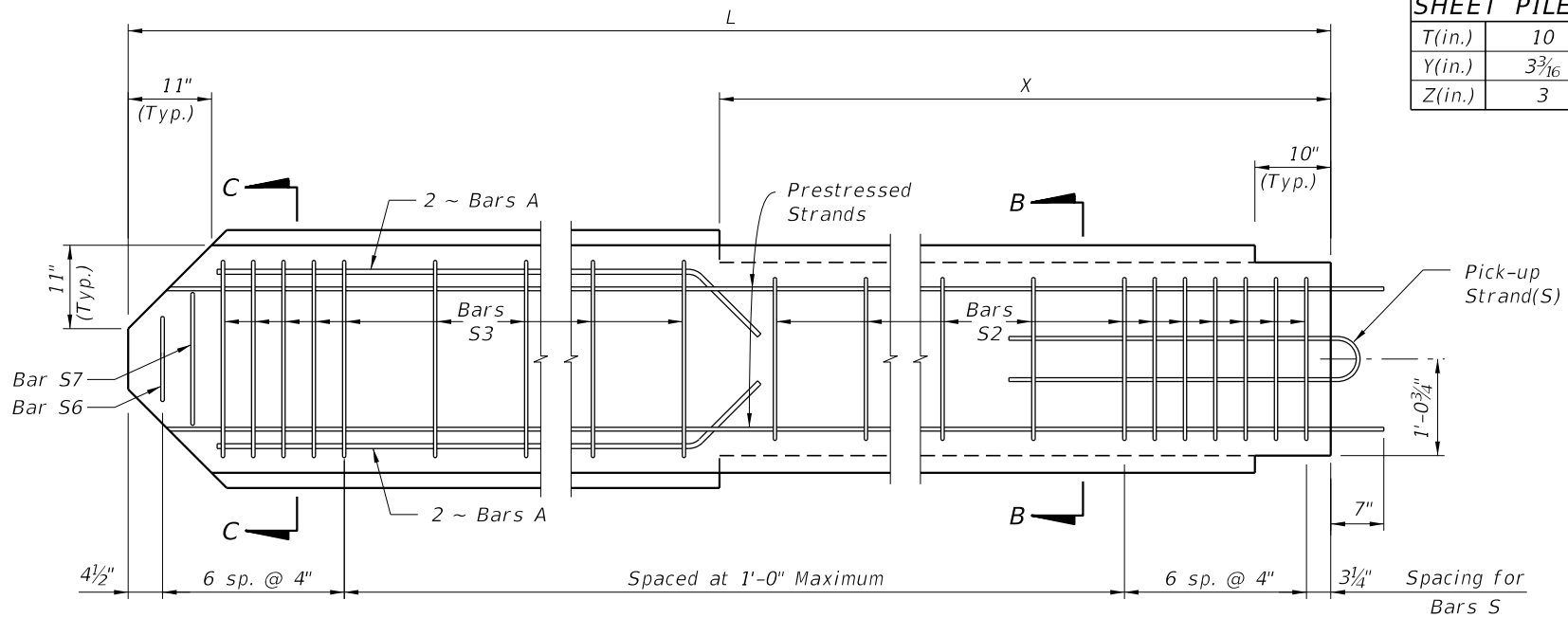

STARTER PILE

SHEET PILE DIMENSIONS		
T(in.)	10	12
Y(in.)	3 3/16	4 3/16
Z(in.)	3	4

BAR BENDING DIAGRAMS

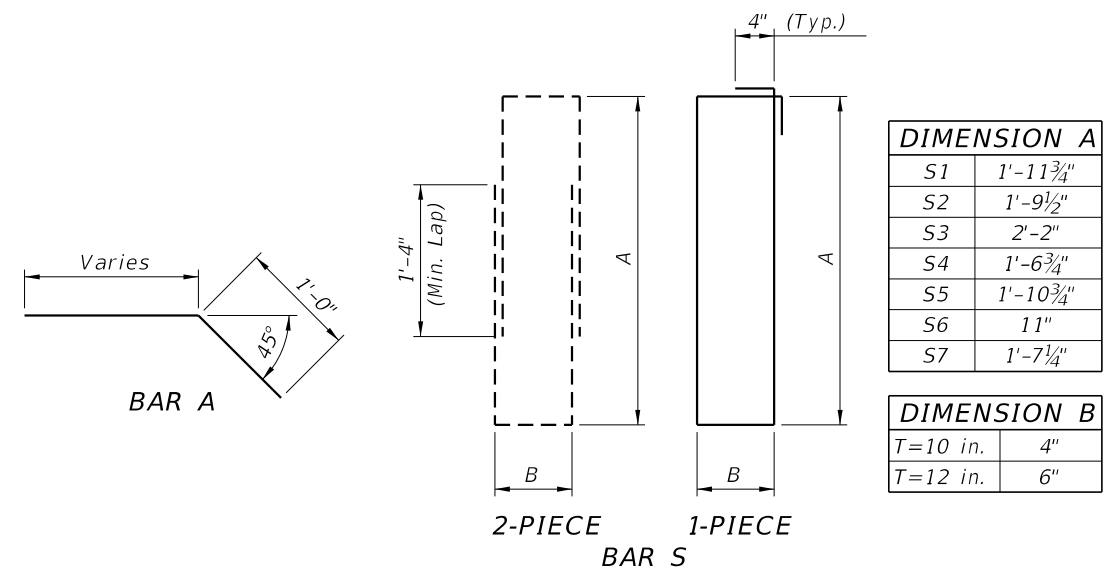

NOTES:

1. Intermediate Prestress Strands not shown in Elevations and Sections.
2. All bar dimensions are out-to-out.
3. Bars A are #5 and Bars S are #4.
4. At the Contractor's option Bars S may be fabricated as a two piece bar as shown in the Bar Bending Diagram.
5. The Contractor may use Deformed Welded Wire Reinforcement meeting the requirements of Specification Section 931 in lieu of Bars A and Bars S if the wire size and spacing provide the same area of reinforcing steel per foot as the Bars shown.
6. For Dimensions L and X see Sheet Pile Data Table in Structures Plans.

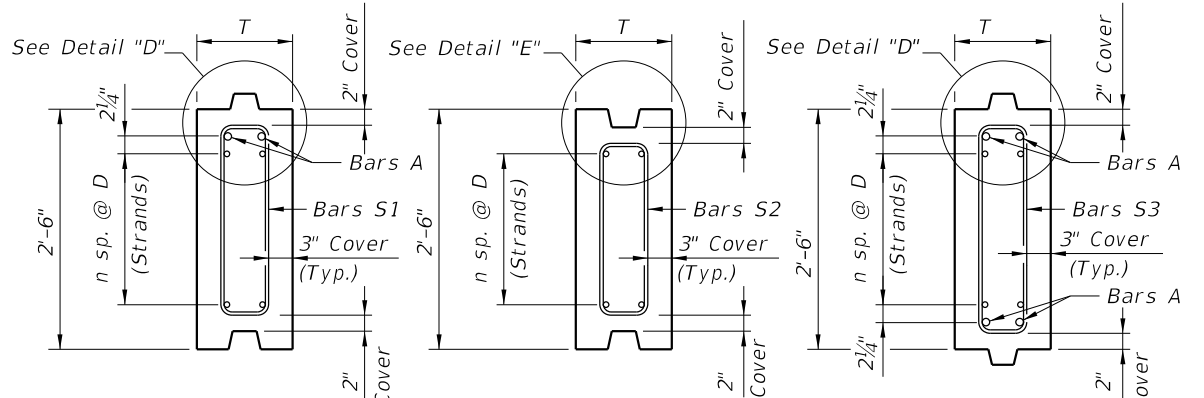

SECTION A-A SECTION B-B SECTION C-C

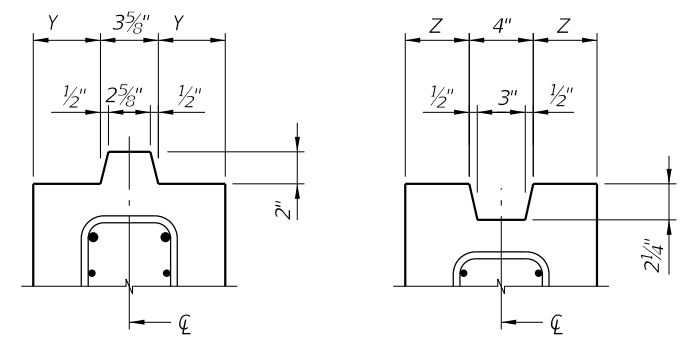

DETAIL "D" (Typical Tongue) DETAIL "E" (Typical Groove)

WALL THICKNESS	STRAND DIA. (in.)	MAXIMUM L	n	D (in.)	TOTAL # OF STRANDS	INITIAL (JACKING) FORCE (Kip)
T=10 in.	0.5	28'-0"	6	3 1/4	14	31
	0.6	27'-0"	4	5	10	44
T=12 in.	0.5	31'-0"	7	2 7/8	16	31
	0.6	30'-0"	5	4	12	44

TYPE "A" STANDARD SECTION

10/30/2018 8:50:00 AM

LAST REVISION	DESCRIPTION:
11/01/18	

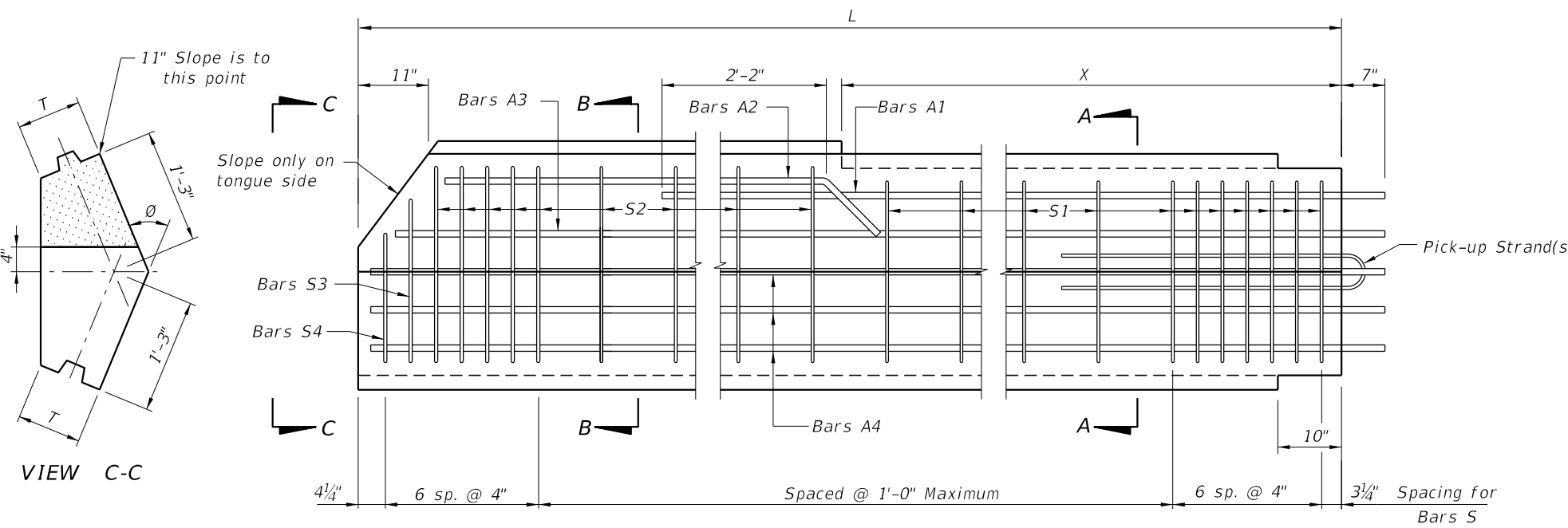

ELEVATION
(TYPE "B1" PILE SHOWN, TYPE "B2" PILE OPPOSITE HAND)

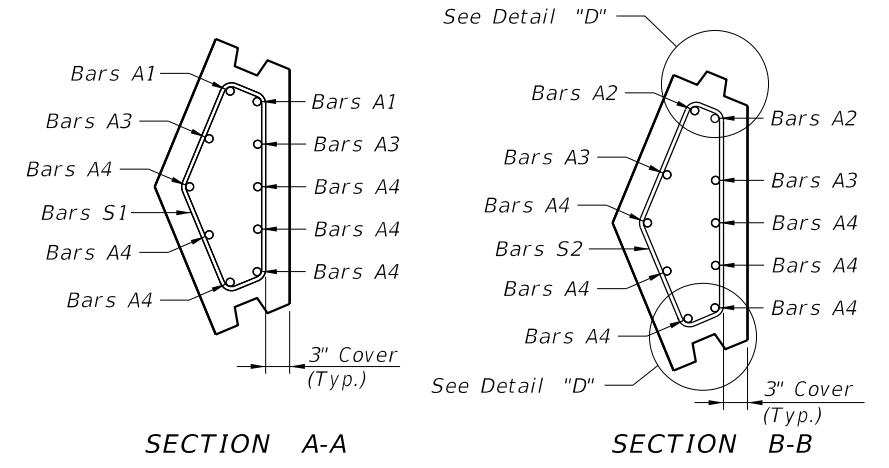

SECTION A-A

SECTION B-B

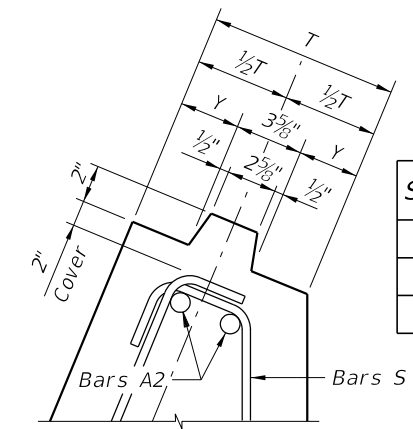

SHEET PILE DIMENSIONS		
T (in.)	10	12
Y (in.)	3 ³ / ₁₆	4 ³ / ₁₆
Z (in.)	3	4

BAR BENDING DIAGRAMS

STIRRUP DIMENSIONS (T = 10")

Ø	BAR MARK	R1	R2	R3	R4	R5	R6	R7	R8
30°	S1	11 ¹ / ₄ "	9 ³ / ₄ "	1'-6 ¹ / ₂ "	2 ¹ / ₂ "	5"	4 ³ / ₄ "	5 ¹ / ₂ "	4 ¹ / ₄ "
	S2	1'-1 ¹ / ₂ "	9 ³ / ₄ "	1'-8 ³ / ₄ "	2 ¹ / ₂ "	4 ¹ / ₂ "	5 ¹ / ₂ "	5 ³ / ₄ "	4 ¹ / ₄ "
	S3	11 ¹ / ₄ "	8"	1'-6"	1 ¹ / ₄ "	5"	4 ¹ / ₂ "	4 ¹ / ₂ "	5"
	S4	11 ¹ / ₄ "	4 ¹ / ₄ "	1'-1 ³ / ₄ "	1 ³ / ₄ "	5"	3 ³ / ₄ "	2 ¹ / ₂ "	6 ¹ / ₄ "
45°	S1	11 ¹ / ₂ "	8"	1'-4"	4"	5 ¹ / ₂ "	6 ¹ / ₂ "	8"	4"
	S2	1'-1 ³ / ₄ "	8"	1'-5 ³ / ₄ "	4"	4 ¹ / ₂ "	7 ¹ / ₂ "	8"	4"
	S3	11 ¹ / ₂ "	6 ³ / ₄ "	1'-4"	2 ¹ / ₄ "	5 ¹ / ₂ "	6 ³ / ₄ "	6 ³ / ₄ "	5 ¹ / ₂ "
	S4	11 ¹ / ₂ "	3 ¹ / ₂ "	1'-0"	3"	5 ¹ / ₂ "	5"	3 ¹ / ₂ "	7"
60°	S1	1'-0"	6"	1'-0 ³ / ₄ "	5 ¹ / ₄ "	6"	7 ¹ / ₄ "	10 ¹ / ₄ "	3"
	S2	1'-2"	6"	1'-2 ³ / ₄ "	5 ¹ / ₄ "	4 ³ / ₄ "	8 ³ / ₄ "	10 ³ / ₄ "	3"
	S3	1'-0"	4 ³ / ₄ "	1'-1 ¹ / ₂ "	3 ¹ / ₄ "	6"	8"	8 ³ / ₄ "	5 ¹ / ₄ "
	S4	1'-0"	2 ¹ / ₂ "	10"	4 ¹ / ₂ "	6"	5 ³ / ₄ "	4"	7 ¹ / ₂ "

STIRRUP DIMENSIONS (T = 12")

Ø	BAR MARK	R1	R2	R3	R4	R5	R6	R7	R8
30°	S1	11 ¹ / ₂ "	10"	1'-6"	3 ¹ / ₂ "	7"	4 ³ / ₄ "	5 ³ / ₄ "	6"
	S2	1'-1 ³ / ₄ "	10"	1'-8 ¹ / ₄ "	3 ¹ / ₂ "	6 ¹ / ₂ "	5 ¹ / ₄ "	5 ³ / ₄ "	6"
	S3	11 ¹ / ₂ "	8 ¹ / ₄ "	1'-5 ³ / ₄ "	2"	7"	4 ³ / ₄ "	4 ¹ / ₂ "	7 ¹ / ₄ "
	S4	11 ¹ / ₂ "	4"	1'-1 ¹ / ₄ "	2 ¹ / ₄ "	7"	3 ³ / ₄ "	2 ¹ / ₂ "	8 ¹ / ₄ "
45°	S1	1'-0"	8 ¹ / ₂ "	1'-3 ¹ / ₄ "	5 ¹ / ₄ "	7 ¹ / ₂ "	6 ¹ / ₄ "	8 ¹ / ₂ "	5 ¹ / ₄ "
	S2	1'-2 ¹ / ₄ "	8 ¹ / ₂ "	1'-5 ¹ / ₂ "	5 ¹ / ₄ "	6 ¹ / ₂ "	7 ¹ / ₄ "	8 ¹ / ₂ "	5 ¹ / ₄ "
	S3	1'-0"	7"	1'-4"	3"	7 ¹ / ₂ "	6 ³ / ₄ "	7"	7 ¹ / ₄ "
	S4	1'-0"	3 ¹ / ₂ "	11 ³ / ₄ "	3 ³ / ₄ "	7 ¹ / ₂ "	5"	3 ¹ / ₂ "	9"
60°	S1	1'-0 ¹ / ₂ "	6 ¹ / ₄ "	11 ³ / ₄ "	7"	8"	6 ³ / ₄ "	10 ³ / ₄ "	4"
	S2	1'-2 ³ / ₄ "	6 ¹ / ₄ "	1'-2"	7"	6 ³ / ₄ "	8"	10 ³ / ₄ "	4"
	S3	1'-0 ¹ / ₂ "	5"	1'-1 ¹ / ₂ "	4"	8"	8"	9"	7"
	S4	1'-0 ¹ / ₂ "	2 ¹ / ₂ "	9 ¹ / ₂ "	5 ¹ / ₂ "	8"	5 ¹ / ₂ "	4 ¹ / ₄ "	9 ¹ / ₄ "

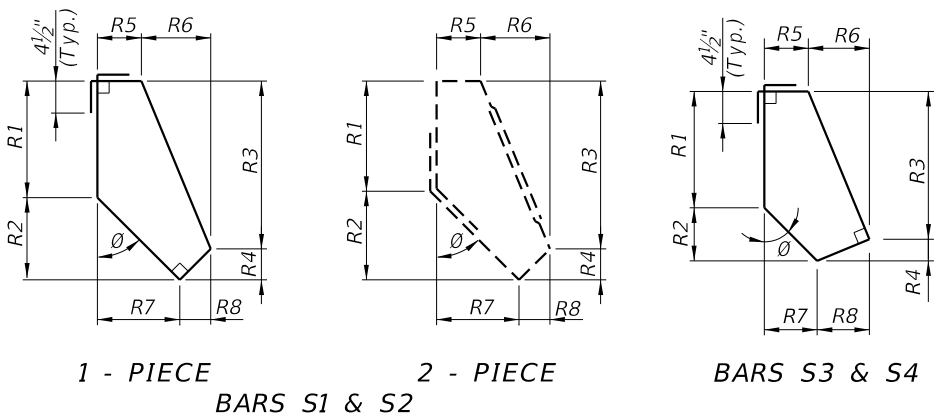

DETAIL "D"
(TYPE "B1" PILE SHOWN, TYPE "B2" PILE OPPOSITE HAND)

- NOTES:**
- This drawing includes details for precast concrete corner piles for 10" and 12" thick sheet pile systems. The details apply equally to both thicknesses.
 - The bar configurations shown in Sections A-A and B-B shall be used for Ø angles between 15° and 75°. For Ø angles not shown, the reinforcing bar dimensions may be interpolated or extrapolated from the stirrup dimensions shown.
 - All bar dimensions are out-to-out.
 - Bars A are #8 and Bars S are #4.
 - Values for Stirrup Dimensions are shown for Ø equal to 30°, 45° & 60° only.
 - At the Contractor's option Bars S may be fabricated as a 2 piece bar with a minimum lap length of 1'-4", as shown in Bar Bending Diagrams.
 - If Type "B1" or "B2" pile is used as a Starter Pile show tongue on both sides of pile from Dim. X down. Show dimensions for Bars S2, S3 & S4 in shop drawings.
 - If tongue must be on the opposite side from that shown all dimensions and Bars A, S2, S3 and S4 will be the same but opposite hand.
 - For Dimensions L, X and Angle Ø, see Sheet Pile Data Table in Structures Plans.

TYPE "B1" AND "B2" - VARIABLE ANGLE CORNER PILE

10/30/2018 8:50:06 AM

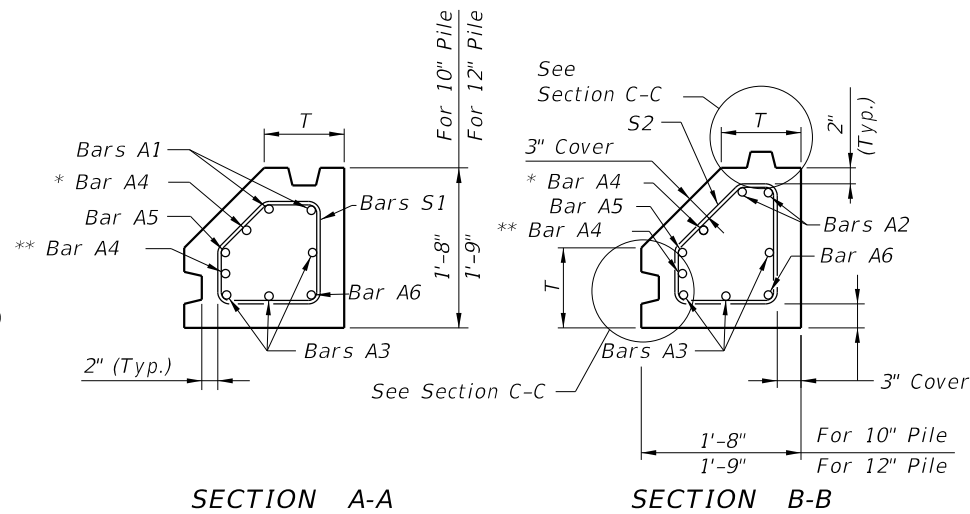
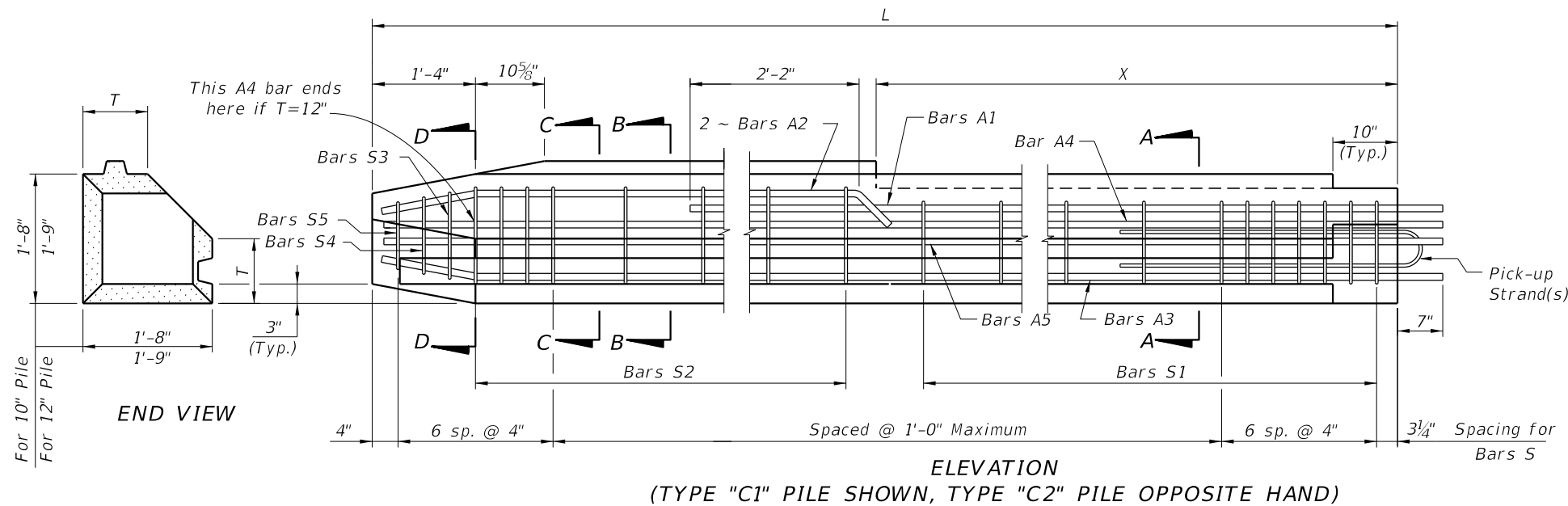

* This Bar A4 shall be 1'-2" shorter than other A4 bars for T = 12".

** This Bar A4 (not shown in elevation) is included only if T = 12".

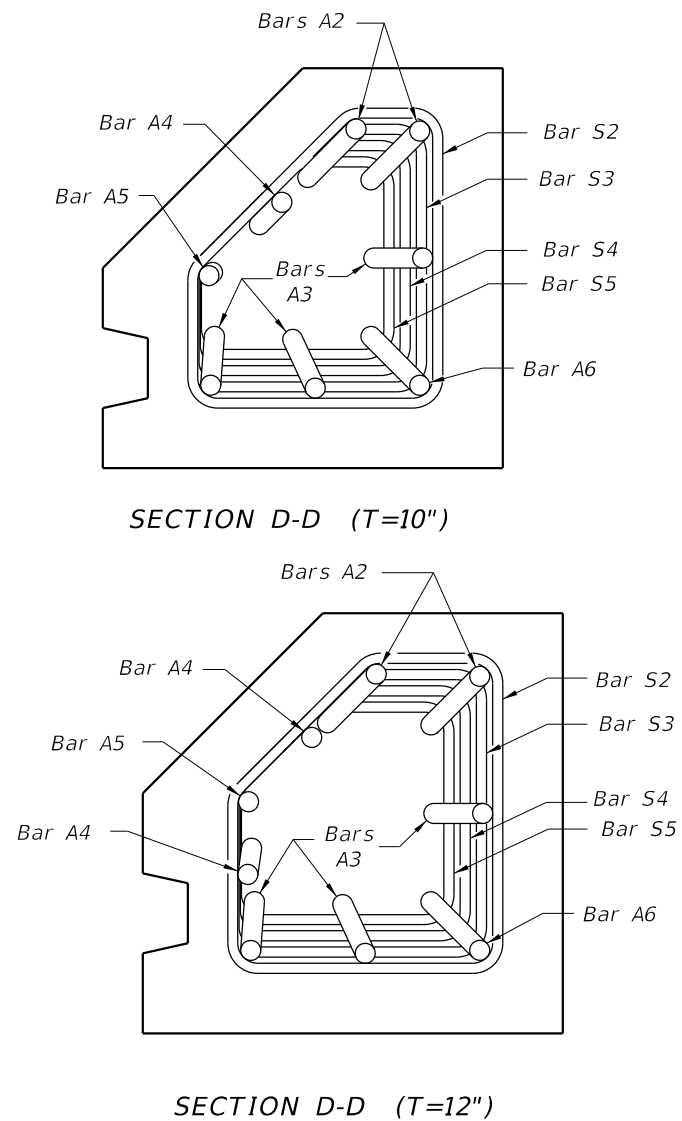
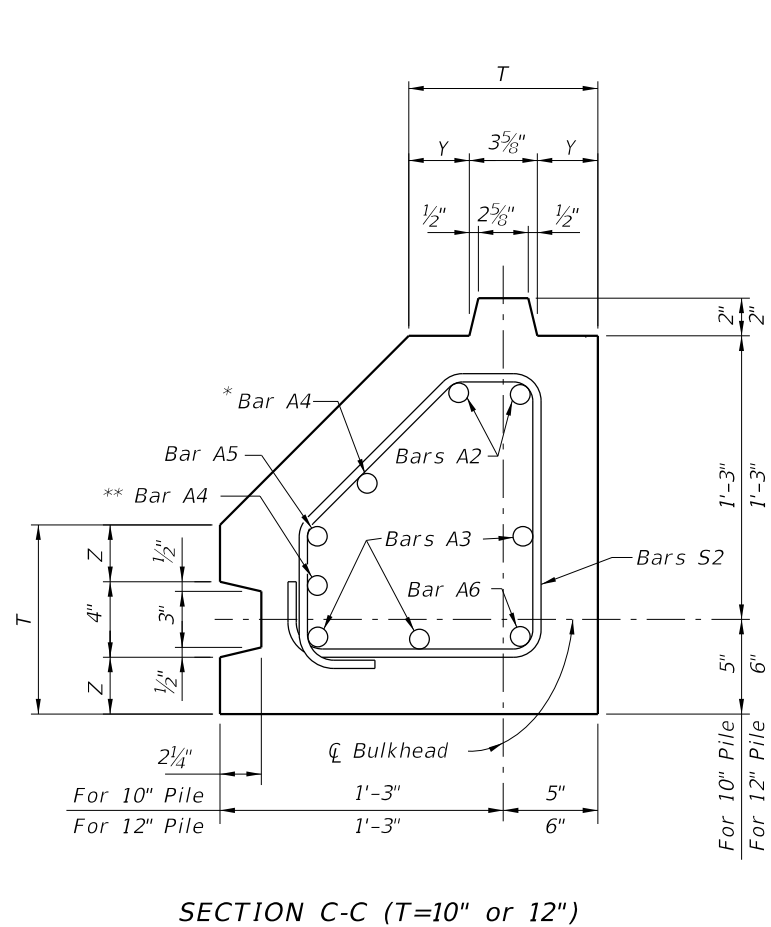

STIRRUP DIMENSIONS					
θ	T (in.)	BAR MARK	R1	R2	R3
90°	10	S1	7"	5 3/4"	7"
		S2	7"	8"	4 3/4"
		S3	6 1/4"	7 1/4"	4 3/4"
		S4	5 1/2"	6 1/2"	4 3/4"
		S5	4 3/4"	5 3/4"	4 3/4"
	12	S1	9"	4 3/4"	9"
		S2	9"	7"	6 3/4"
		S3	8 1/4"	6 1/4"	6 3/4"
		S4	7 1/2"	5 1/2"	6 3/4"
		S5	6 3/4"	4 3/4"	6 3/4"

SHEET PILE DIMENSIONS		
T (in.)	10	12
Y (in.)	3 3/16	4 3/16
Z (in.)	3	4

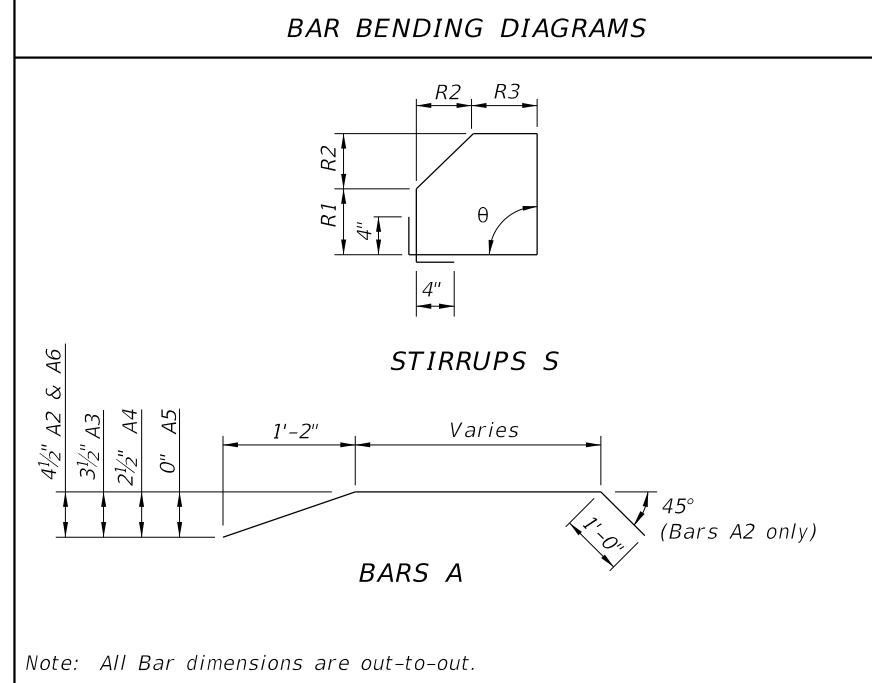

- NOTES:
1. All bar dimensions are out-to-out.
 2. Bars A are #8 and Bars S are #4.
 3. This drawing includes information for precast Corner Piles for 10" and 12" thick Sheet Pile systems. The details apply to both thicknesses but the bar configurations change slightly according to the thickness values used.
 4. If Type "C1" or "C2" pile is used as a Starter Pile show tongue on both sides of pile from Dim. X down. Show dimensions for Bars S2, S3, S4 & S5 in shop drawings.
 5. If tongue must be on opposite side (Groove Side) from that shown, all dimensions and reinforcement shall follow the corresponding Tongue or Groove side.
 6. For Dimensions L and X see Sheet Pile Data Table in Structures Plans.

TYPE "C1" AND "C2" - RIGHT ANGLE CORNER PILE

10/30/2018 8:50:09 AM

LAST REVISION 07/01/12	DESCRIPTION:	FDOT FY 2019-20 STANDARD PLANS	PRECAST CONCRETE SHEET PILE WALL (CONVENTIONAL)	INDEX 455-400	SHEET 4 of 4
---------------------------	--------------	--------------------------------------	----------------------------------------------------	------------------	-----------------

CFRP/GFRP SHEET PILE DESIGN CRITERIA AND NOTES

DESCRIPTION:

This Index includes details for six types of piles with two thicknesses. Type "A" is prestressed concrete construction with CFRP or HSSS strands. Types "B1", "B2", "C1" and "C2" piles (corner piles) are reinforced concrete construction. Manufacture, cure and install Sheet Piles in accordance with the requirements of the contract documents.

MATERIALS: (for materials not listed refer to the Specifications)

CONCRETE

Class: V (Special)
 Unit weight: 145 pcf
 Modulus of Elasticity: Based on the use of Florida limerock aggregate concrete

REINFORCING BARS

Glass Fiber Reinforced Polymer (GFRP) bars meeting the requirements of Specification Section 932.

PRESTRESSING STRAND

Stainless Steel: Prestressing steel shall be seven-wire HSSS, UNS S32205 (Type 2205) or UNS S31803 strand, meeting the requirements of Specification Section 933.
 Carbon FRP: Prestressing strand shall be CFRP strand, meeting the requirements of Specification Section 933.

DESIGN PARAMETERS:

Type "A"

Concrete Compressive Strength at release of prestressing: 4000 psi minimum
 Uniform compression after prestressing losses: 700 psi minimum
 Pick-up, Storage and Transportation: 450 psi tension with 1.5 times pile self weight for single-point pick-up at $f'c \geq 6000$ psi

Types "B1", "B2", "C1" & "C2"

Pick-up, Storage and Transportation: Minimum compressive strength $f'ci \geq 4000$ psi required for two-point pick-up; $f'c \geq 6000$ psi for single-point pick-up.

PLASTIC FILTER FABRIC:

The plastic filter fabric shall extend to the bottom of the "X" dimension.

PILE PICK-UP AND HANDLING:

Two-point pick-up for lifting out of forms & two-point support for storage & transportation.
 Single-point pick-up for installation only.

PILE FIT-UP:

The 2'-6" Sheet Pile dimension is nominal. This dimension may be shortened by the Manufacturer up to 1/2" to allow for Sheet Pile fit-up in its final position. Minimum Sheet Pile width is 2'-5 1/2". No changes shall be made to the tongues or grooves.

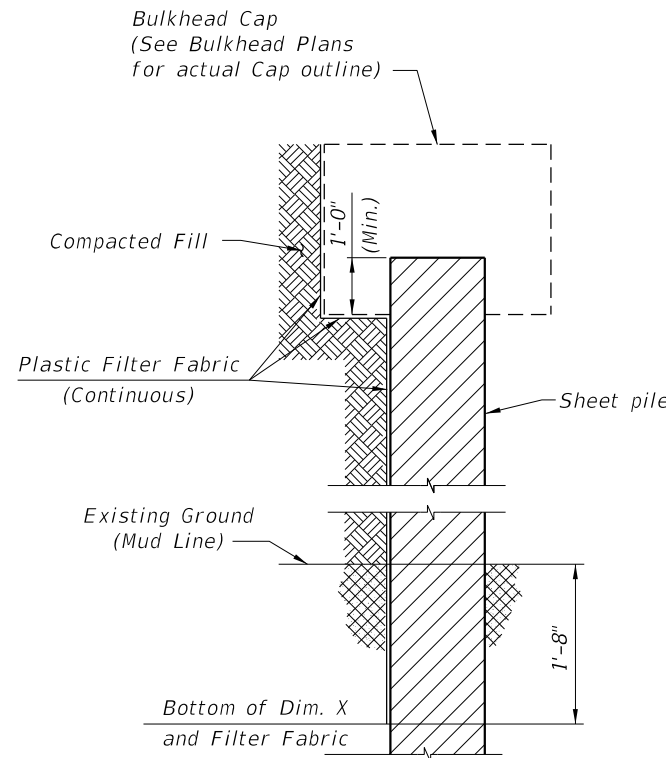

SECTION THRU BULKHEAD
 (Showing Plastic Filter Fabric)

CROSS REFERENCES:
 For Dimensions L and X see Sheet Pile Wall Data Table in Structures Plans.

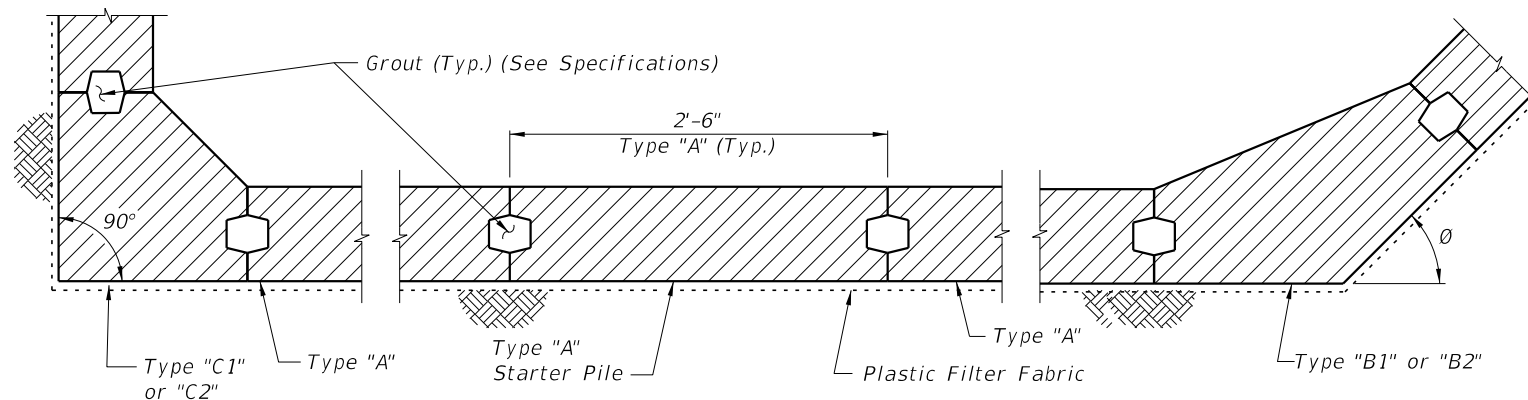

DETAIL "A"
 (Cap and Anchoring System Not Shown)
 (Section Taken Above Dimension X)

NOTE: Detail "A" shows a Part-Plan View of an assumed bulkhead. See Bulkhead plans for actual Plan View.

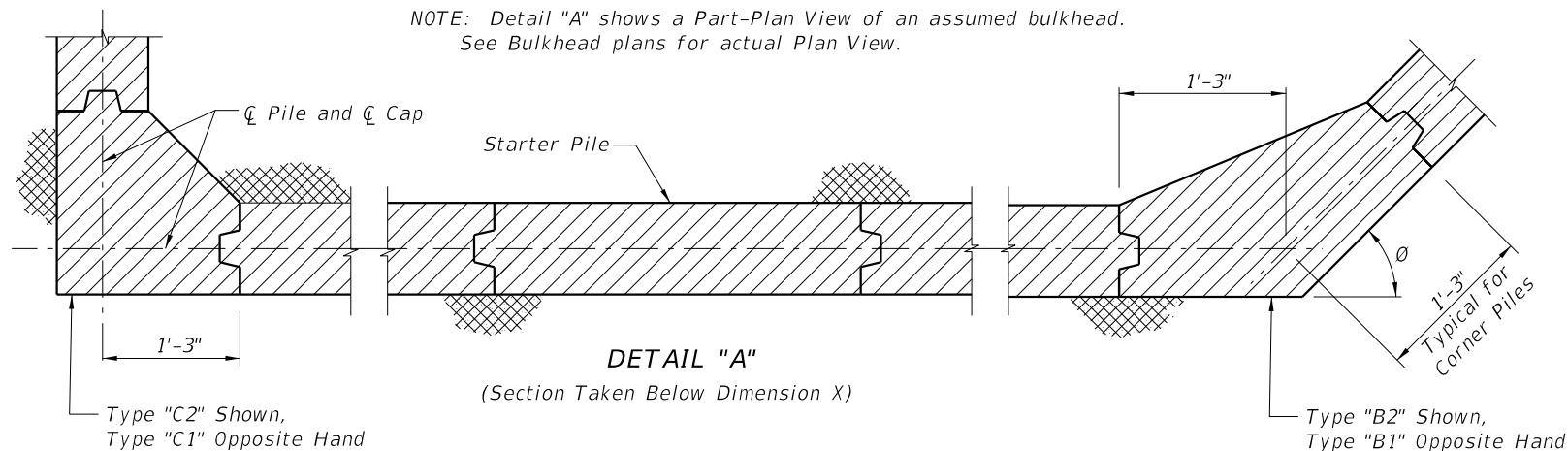

DETAIL "A"
 (Section Taken Below Dimension X)

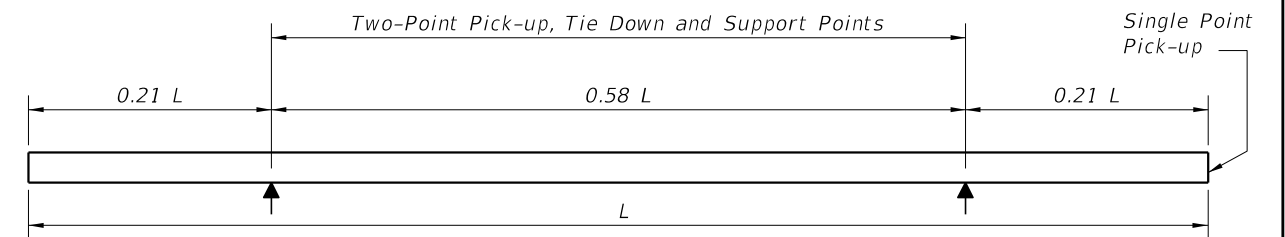

PILE STORAGE AND TRANSPORTATION SUPPORT DETAILS

NOTES AND DETAILS

10/30/2018 8:50:12 AM

LAST REVISION 11/01/16	DESCRIPTION:	 FY 2019-20 STANDARD PLANS	PRECAST CONCRETE SHEET PILE WALL (CFRP/GFRP & HSSS/GFRP)	INDEX 455-440	SHEET 1 of 4
---------------------------	--------------	-----------------------------------------------------------------------------------------------------------------------	-------------------------------------------------------------	------------------	-----------------

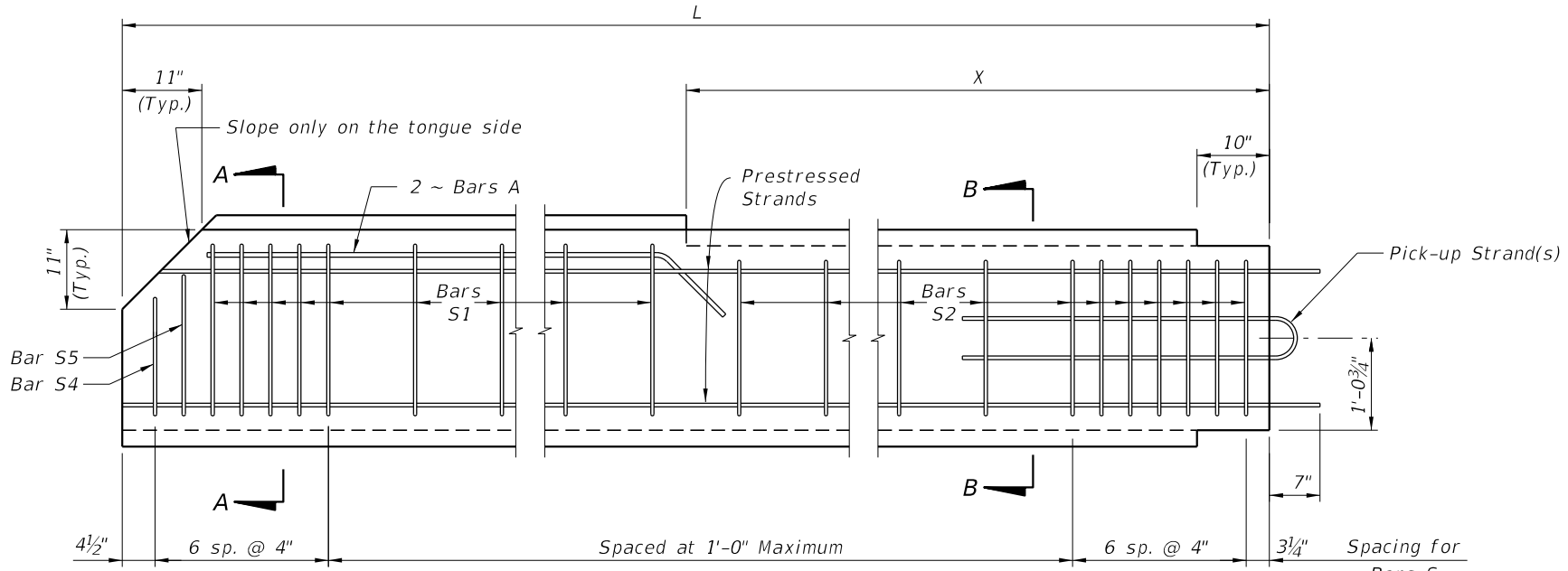

TYPICAL PILE

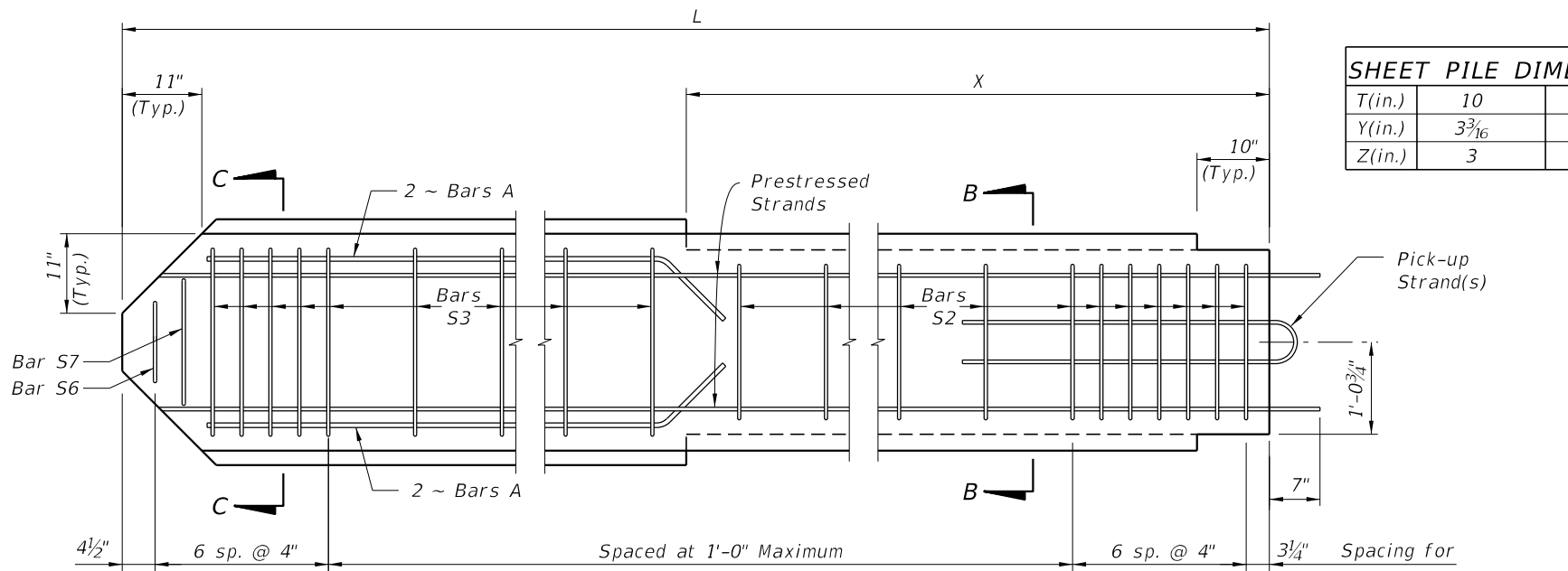

STARTER PILE

SHEET PILE DIMENSIONS		
T(in.)	10	12
Y(in.)	3 3/16	4 3/16
Z(in.)	3	4

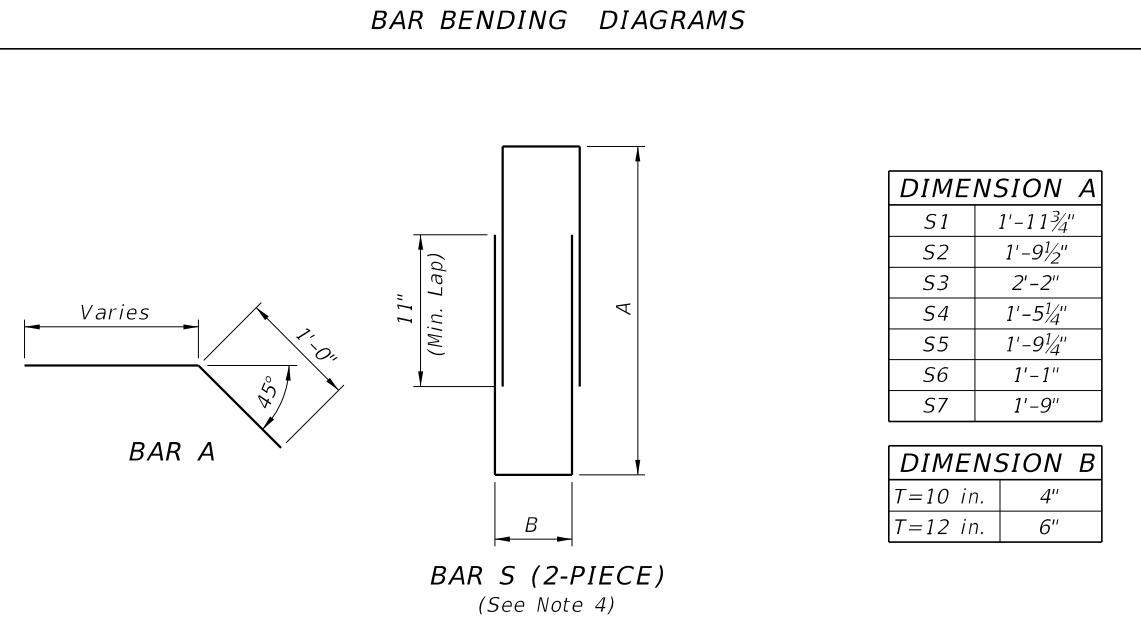

- NOTES:
1. Intermediate Prestress Strands not shown in Elevations and Sections.
 2. All bar dimensions are out-to-out.
 3. Bars A are GFRP #5
 4. Bars S are GFRP #4 and may be a single closed bar (hoop) with equivalent area and tensile strength.
 5. For Dimensions L and X see Sheet Pile Data Table in Structures Plans.

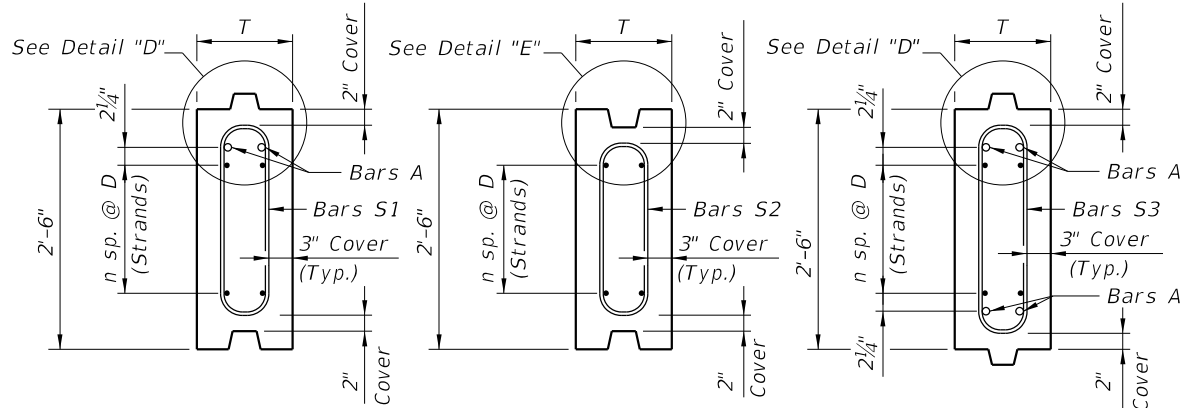

Strand Material	Wall Thickness	STRAND DIA. (in.)	MAXIMUM L *	n	D (in.)	TOTAL # OF STRANDS	Initial (Jacking) FORCE (Kip)
CFRP Strand	T=10 in.	0.49 (12.5mm)	26'-0"	4	4	10	28.7
		0.5 (12.7mm)	27'-0"	3	5 1/4 ⁽²⁾	8	41.3
		0.6 (15.2mm)	27'-0"	3	5 1/4 ⁽²⁾	8	42.7
	T=12 in.	0.49 (12.5mm)	31'-0"	5	3 1/4 ⁽¹⁾	12	28.7
		0.5 (12.7mm)	31'-0"	3	5 1/4 ⁽²⁾	8	41.3
		0.6 (15.2mm)	31'-0"	3	5 1/4 ⁽²⁾	8	42.7
HSSS Strand	T=10 in.	0.5 (12.7mm)	27'-0"	5	3 1/4 ⁽¹⁾	12	25.7
		0.6 (15.2mm)	26'-0"	3	5 1/4 ⁽²⁾	8	36.5
	T=12 in.	0.5 (12.7mm)	32'-0"	6	2 3/4 ⁽³⁾	14	25.7
		0.6 (15.2mm)	32'-0"	4	4	10	36.5

- Alternate symmetrical strand patterns:
- (1) 4 sp. @ 2" & 1 sp. @ 8"
 - (2) 2 sp. @ 4" & 1 sp. @ 8"
 - (3) 4 sp. @ 2" & 2 sp. @ 4"

* Based on lifting using single point pick-up.

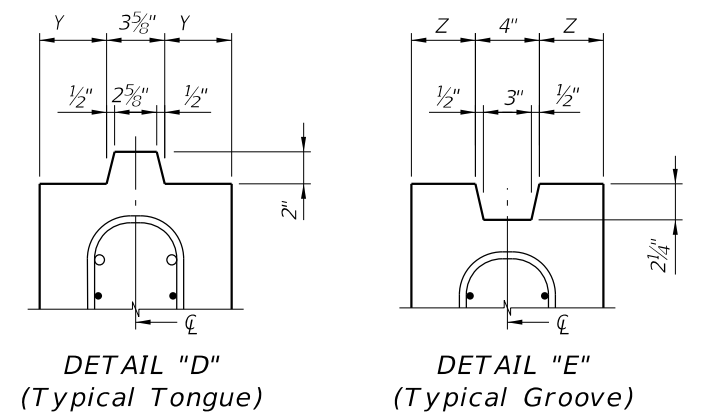

TYPE "A" STANDARD SECTION

10/30/2018 8:50:16 AM

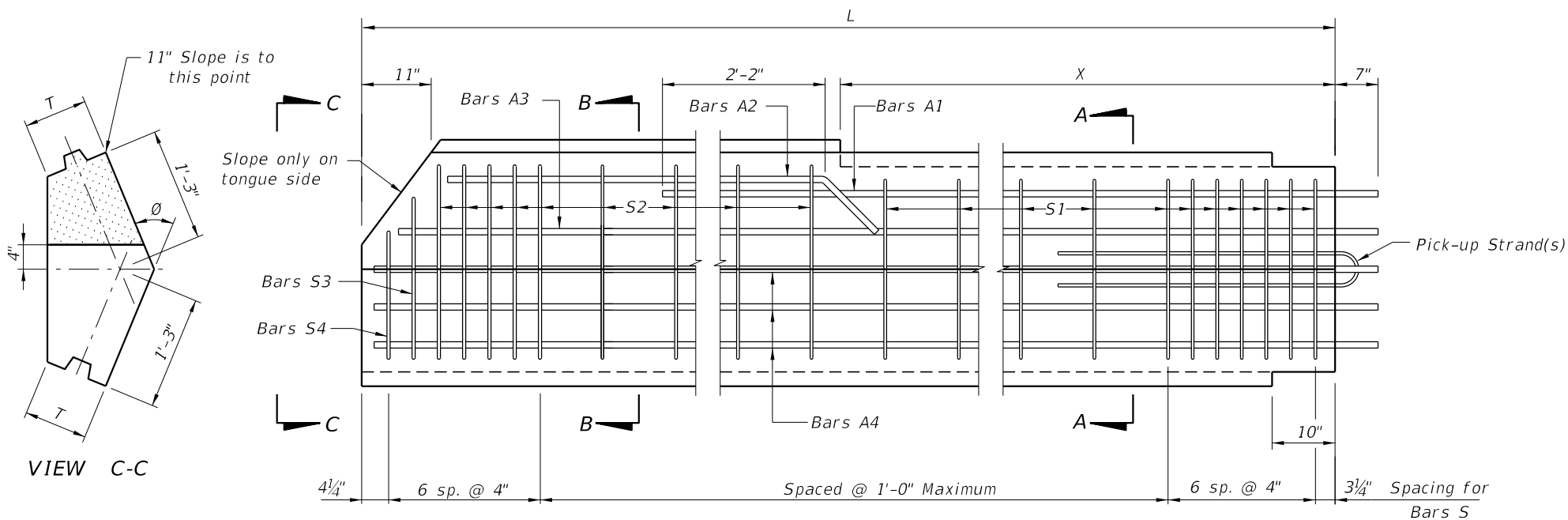

ELEVATION
(TYPE "B1" PILE SHOWN, TYPE "B2" PILE OPPOSITE HAND)

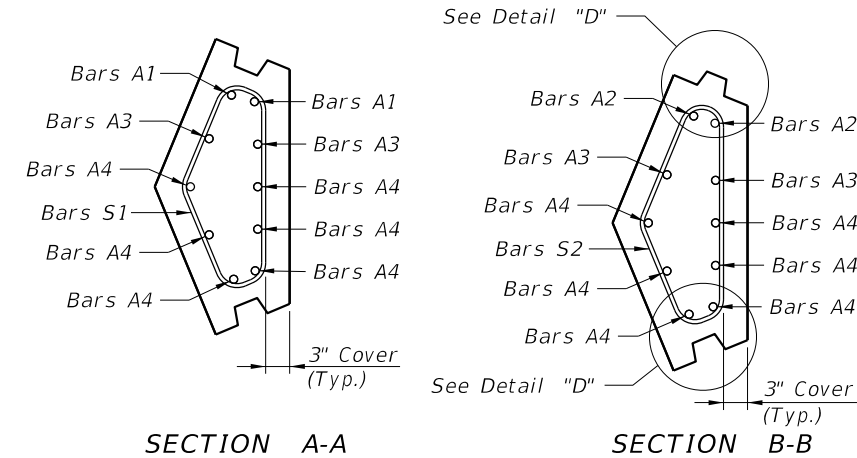

SECTION A-A

SECTION B-B

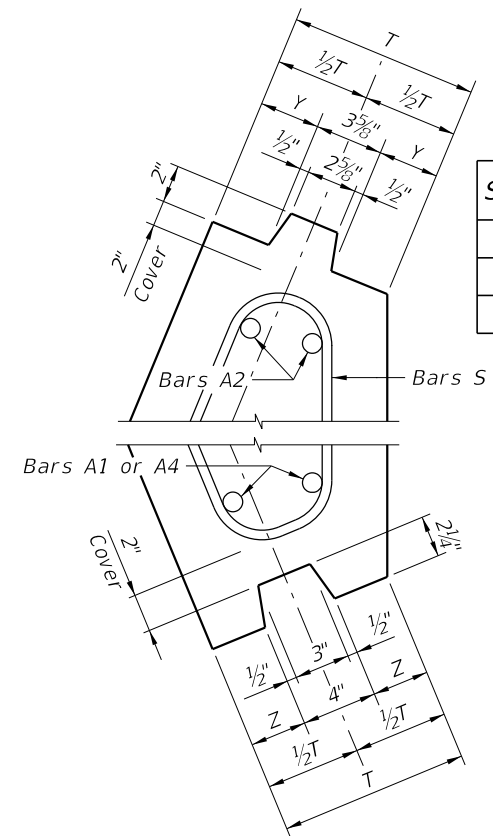

SHEET PILE DIMENSIONS		
T (in.)	10	12
Y (in.)	3 ³ / ₁₆	4 ³ / ₁₆
Z (in.)	3	4

DETAIL "D"
(TYPE "B1" PILE SHOWN, TYPE "B2" PILE OPPOSITE HAND)

BAR BENDING DIAGRAMS

STIRRUP DIMENSIONS (T = 10")									
Ø	BAR MARK	R1	R2	R3	R4	R5	R6	R7	R8
30°	S1	11 1/4"	9 3/4"	1'-6 1/2"	2 1/2"	5"	4 3/4"	5 1/2"	4 1/4"
	S2	1'-1 1/2"	9 3/4"	1'-8 3/4"	2 1/2"	4 1/2"	5 1/2"	5 3/4"	4 1/4"
	S3	11 1/4"	8"	1'-6"	1 1/4"	5"	4 1/2"	4 1/2"	5"
	S4	11 1/4"	4 1/4"	1'-1 3/4"	1 3/4"	5"	3 3/4"	2 1/2"	6 1/4"
45°	S1	11 1/2"	8"	1'-4"	4"	5 1/2"	6 1/2"	8"	4"
	S2	1'-1 3/4"	8"	1'-5 3/4"	4"	4 1/2"	7 1/2"	8"	4"
	S3	11 1/2"	6 3/4"	1'-4"	2 1/4"	5 1/2"	6 3/4"	6 3/4"	5 1/2"
	S4	11 1/2"	3 1/2"	1'-0"	3"	5 1/2"	5"	3 1/2"	7"
60°	S1	1'-0"	6"	1'-0 3/4"	5 1/4"	6"	7 1/4"	10 1/4"	3"
	S2	1'-2"	6"	1'-2 3/4"	5 1/4"	4 3/4"	8 3/4"	10 1/2"	3"
	S3	1'-0"	4 3/4"	1'-1 1/2"	3 1/4"	6"	8"	8 3/4"	5 1/4"
	S4	1'-0"	2 1/2"	10"	4 1/2"	6"	5 3/4"	4"	7 1/2"

STIRRUP DIMENSIONS (T = 12")									
Ø	BAR MARK	R1	R2	R3	R4	R5	R6	R7	R8
30°	S1	11 1/2"	10"	1'-6"	3 1/2"	7"	4 3/4"	5 3/4"	6"
	S2	1'-1 3/4"	10"	1'-8 1/4"	3 1/2"	6 1/2"	5 1/4"	5 3/4"	6"
	S3	11 1/2"	8 1/4"	1'-5 3/4"	2"	7"	4 3/4"	4 1/2"	7 1/4"
	S4	11 1/2"	4"	1'-1 1/4"	2 1/4"	7"	3 3/4"	2 1/2"	8 1/4"
45°	S1	1'-0"	8 1/2"	1'-3 1/4"	5 1/4"	7 1/2"	6 1/4"	8 1/2"	5 1/4"
	S2	1'-2 1/4"	8 1/2"	1'-5 1/2"	5 1/4"	6 1/2"	7 1/4"	8 1/2"	5 1/4"
	S3	1'-0"	7"	1'-4"	3"	7 1/2"	6 3/4"	7"	7 1/4"
	S4	1'-0"	3 1/2"	11 3/4"	3 3/4"	7 1/2"	5"	3 1/2"	9"
60°	S1	1'-0 1/2"	6 1/4"	11 3/4"	7"	8"	6 3/4"	10 3/4"	4"
	S2	1'-2 3/4"	6 1/4"	1'-2"	7"	6 3/4"	8"	10 3/4"	4"
	S3	1'-0 1/2"	5"	1'-1 1/2"	4"	8"	8"	9"	7"
	S4	1'-0 1/2"	2 1/2"	9 1/2"	5 1/2"	8"	5 1/2"	4 1/4"	9 1/4"

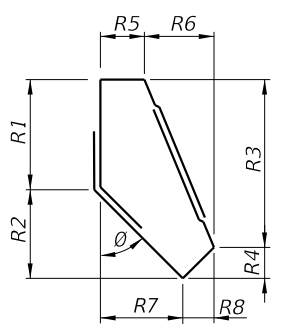

BARS S1 & S2
(2 - PIECE)

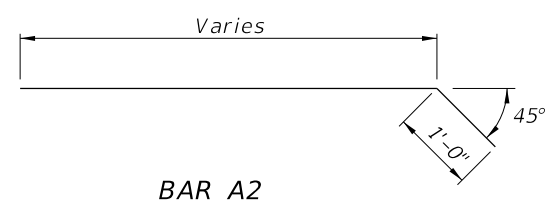

BAR A2

- NOTES:
- This drawing includes details for precast concrete corner piles for 10" and 12" thick sheet pile systems. The details apply equally to both thicknesses.
 - The bar configurations shown in Sections A-A and B-B shall be used for Ø angles between 15° and 75°. For Ø angles not shown, the reinforcing bar dimensions may be interpolated or extrapolated from the stirrup dimensions shown.
 - All bar dimensions are out-to-out.
 - Bars A are GFRP #8 and Bars S are GFRP #4.
 - Values for Stirrup Dimensions are shown for Ø equal to 30°, 45° & 60° only.
 - Bars S are fabricated as a 2 piece stirrup with a minimum lap length of 8", as shown in Bar Bending Diagrams, or a single closed bar (hoop) when approved by the Engineer.
 - If Type "B1" or "B2" pile is used as a Starter Pile show tongue on both sides of pile from Dim. X down. Show dimensions for Bars S2, S3 & S4 in shop drawings.
 - If tongue must be on the opposite side from that shown all dimensions and Bars A, S2, S3 and S4 will be the same but opposite hand.
 - For Dimensions L, X and Angle Ø, see Sheet Pile Data Table in Structures Plans.

TYPE "B1" AND "B2" - VARIABLE ANGLE CORNER PILE

10/30/2018 8:50:22 AM

**GENERAL NOTES FOR
CONCRETE PAVEMENT SUBDRAINAGE**

1. No trench greater than 2' in depth will be allowed overnight. Trenches shall be barricaded at all times.
2. Concrete pavement subdrainage shall be constructed adjacent to the low edge of the roadway pavement and under travel lanes, auxiliary pavement and shoulders, as called for in the plans. When the low edge shifts between outside and inside edges of pavement the concrete pavement subdrainage shall extend 50' beyond and begin 50' before the flat point (100' overlap).

Concrete pavement subdrainage shall be placed on the low side of ramps of crossroad terminals.

3. Concrete pavement subdrainage shall be constructed on a grade parallel with the edge of pavement profile, except on profiles flatter than one-tenth percent (0.10%) the concrete pavement subdrainage shall be constructed on a grade of one-tenth percent (0.10%).

4. Immediately prior to placing the filter fabric the entire vertical face of the concrete pavement shall be cleaned to remove adhering base material and soil.

5. The Contractor shall devise a procedure for holding the filter fabric in position on the vertical face of the trench. The procedure must be approved by the Engineer prior to placement of the draincrete.

6. The upper end of each separate run of the concrete pavement subdrainage pipe shall be capped.

7. Outlet pipes shall be constructed at a maximum of 500' intervals. Elbows or 1/8 bends shall be used to connect the outlet pipe to the concrete pavement subdrain pipe. The elbows or bends shall be of the same material as the outlet pipe but compatible with the pipe.

When directed by the Engineer, outlet pipes shall be stubbed into existing inlets or into existing ditch pavements at an elevation 6" above the inlet flowline or ditch bottom. Concrete apron and bordering sod are not required for stubbed outlets, but replacement sodding will be required at trenches for pipes stubbed into paved ditches.

In sag vertical curves separate outlet pipes for concrete pavement subdrains from opposite directions shall use a single apron unless otherwise shown in the plans or otherwise directed by the Engineer.

Backfill around outlet pipes shall be of cohesive soils, draincrete will not be permitted.

8. Existing paved shoulder that is removed for the construction of outlet pipes shall be replaced with Type SP asphaltic concrete at the rate of 500 LB per SY.

9. The contract unit price for Edgedrain Outlet Pipe (4") LF, shall be full compensation for removal of existing shoulder pavement, trench excavation, pipe and fitting, concrete apron, hardware cloth, sod, stubbing into existing inlets and paved ditches, restoration of ditch pavement, backfill in place, and disposal of excess materials.

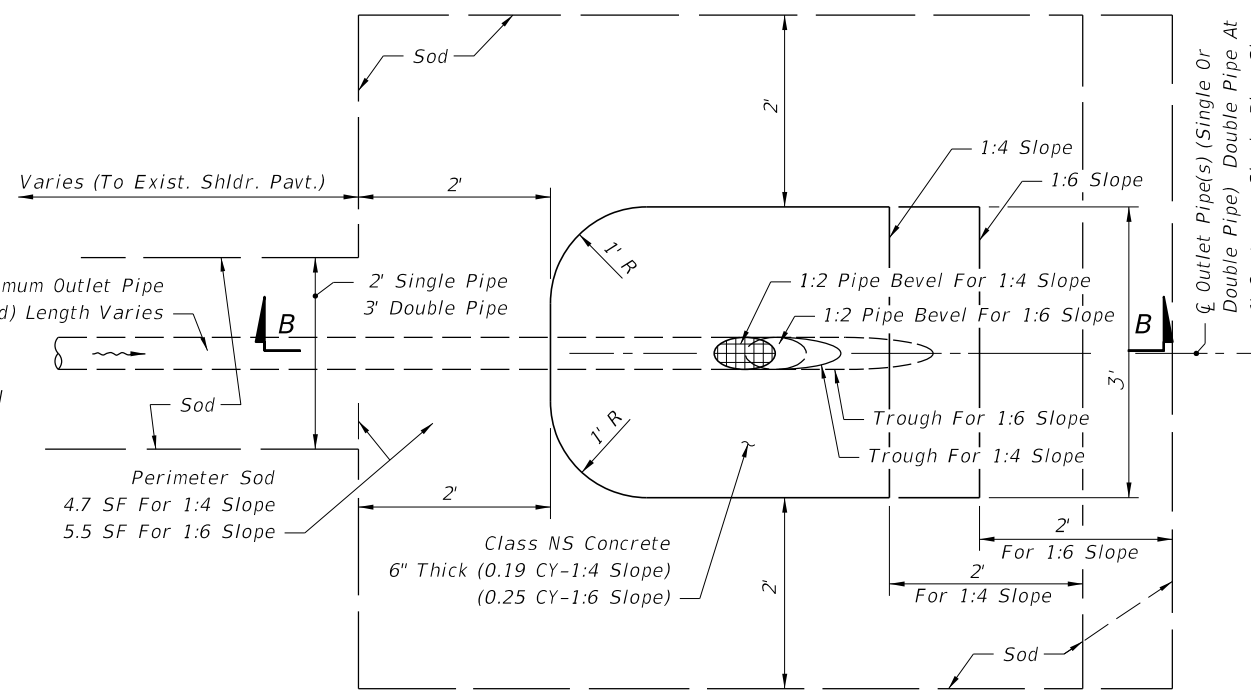

PLAN - OUTLET PIPE APRON

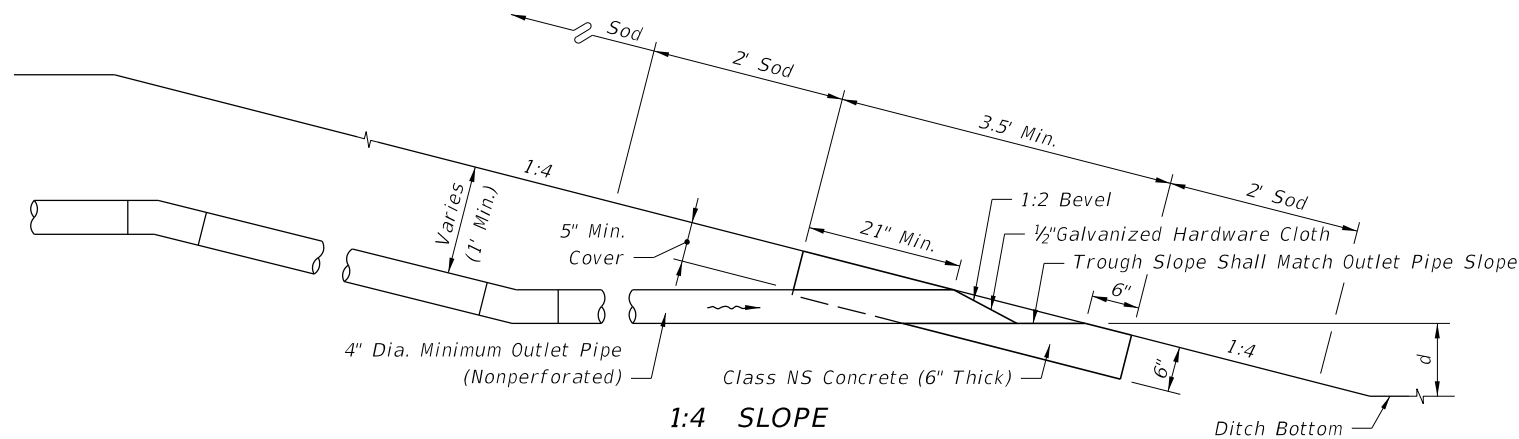

1:4 SLOPE

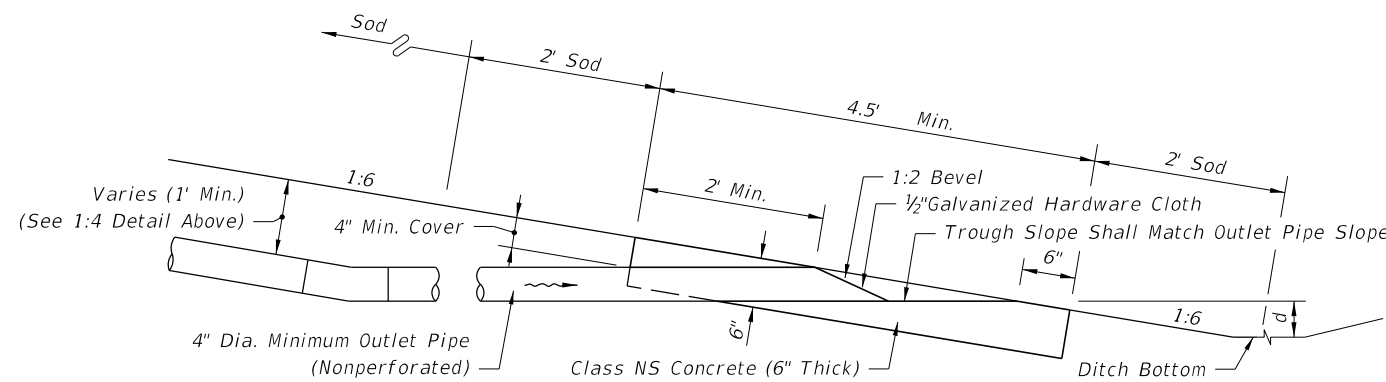

**1:6 SLOPE
SECTIONS BB
4" EDGEDRAIN
EDGEDRAIN OUTLET**

$d = 1.75'$ std. for grassed ditches; $0.5'$ std. for paved ditches
[less is acceptable to provide minimum 0.1% outlet pipe slope]

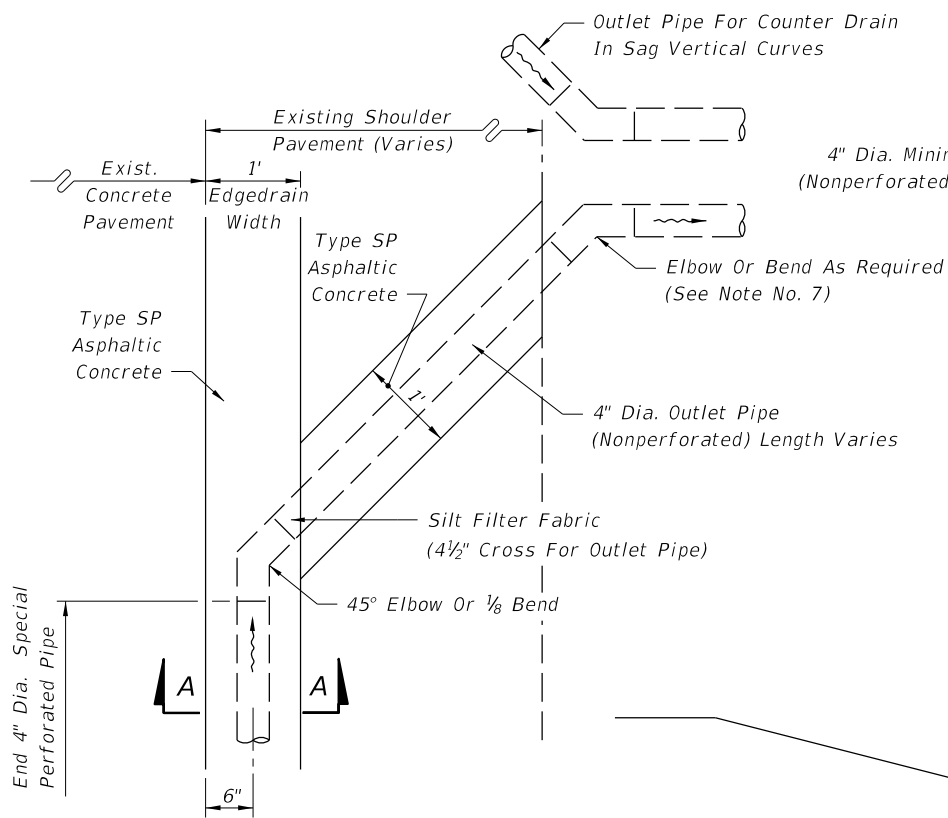

ALIGNMENT OF OUTLET PIPE

NOTE: For Section AA see following Sheets.

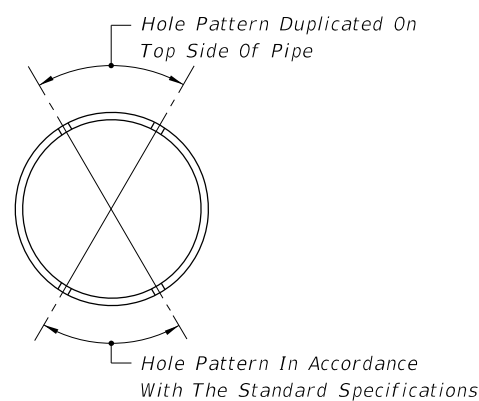

SUBDRAINAGE PIPE

10/30/2018 8:50:29 AM

LAST REVISION 11/01/17	DESCRIPTION:	FDOT FY 2019-20 STANDARD PLANS	CONCRETE PAVEMENT SUBDRAINAGE	INDEX 446-001	SHEET 1 of 4
---------------------------	--------------	--------------------------------------	-------------------------------	------------------	-----------------

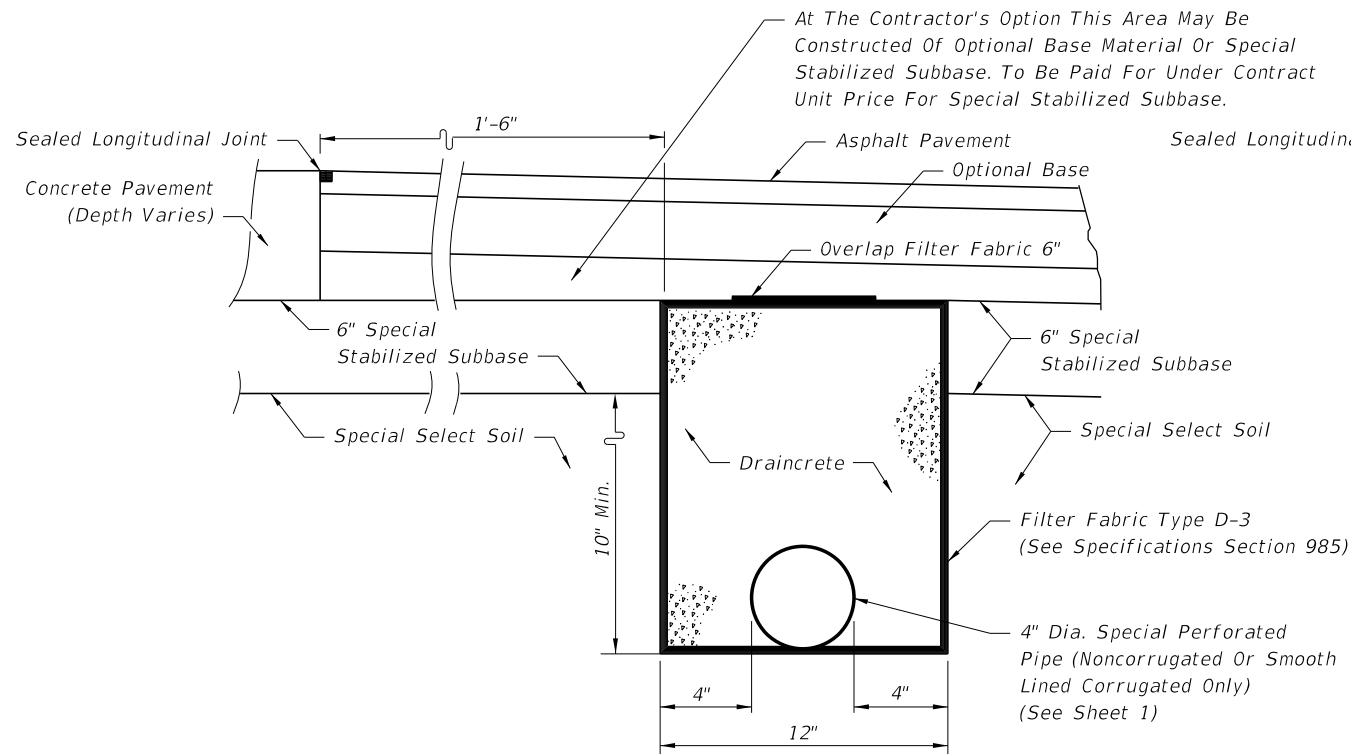

ASPHALT SHOULDERS

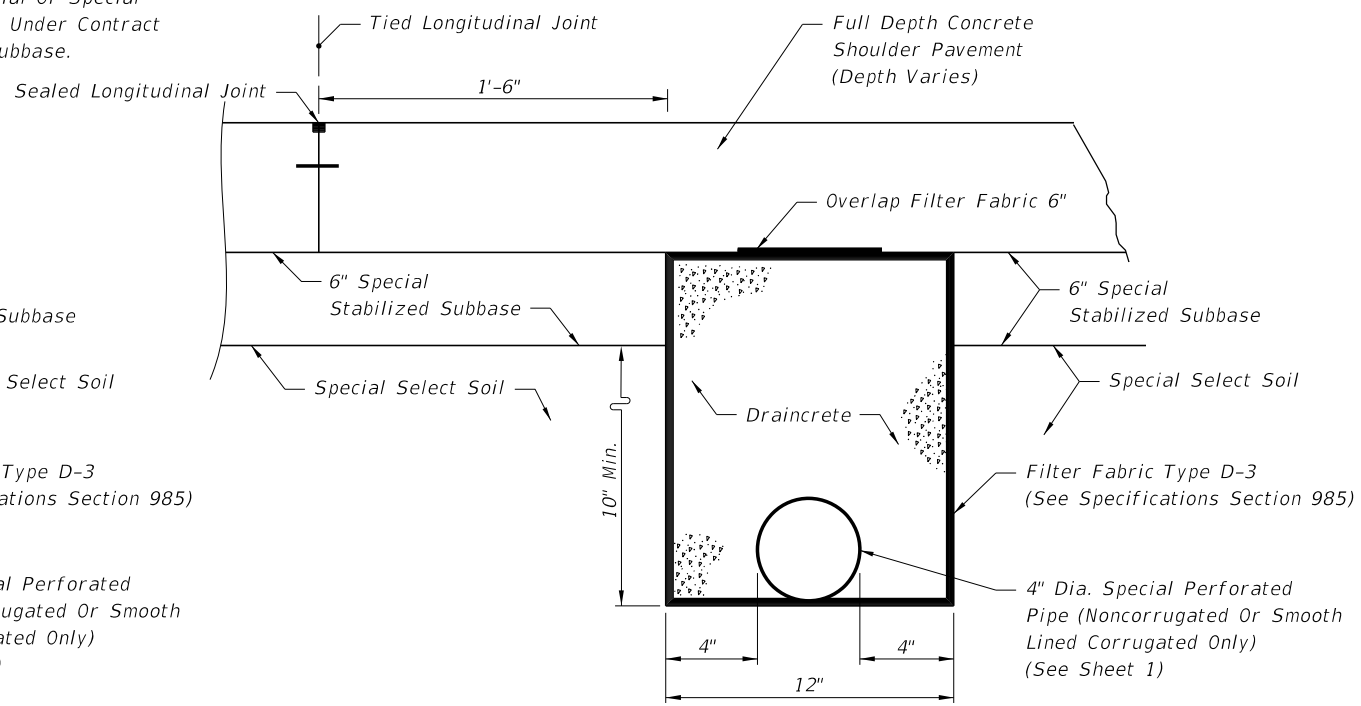

CONCRETE TRAVEL LANES,
SHOULDERS, AND AUXILIARY PAVEMENT

NEW CONSTRUCTION

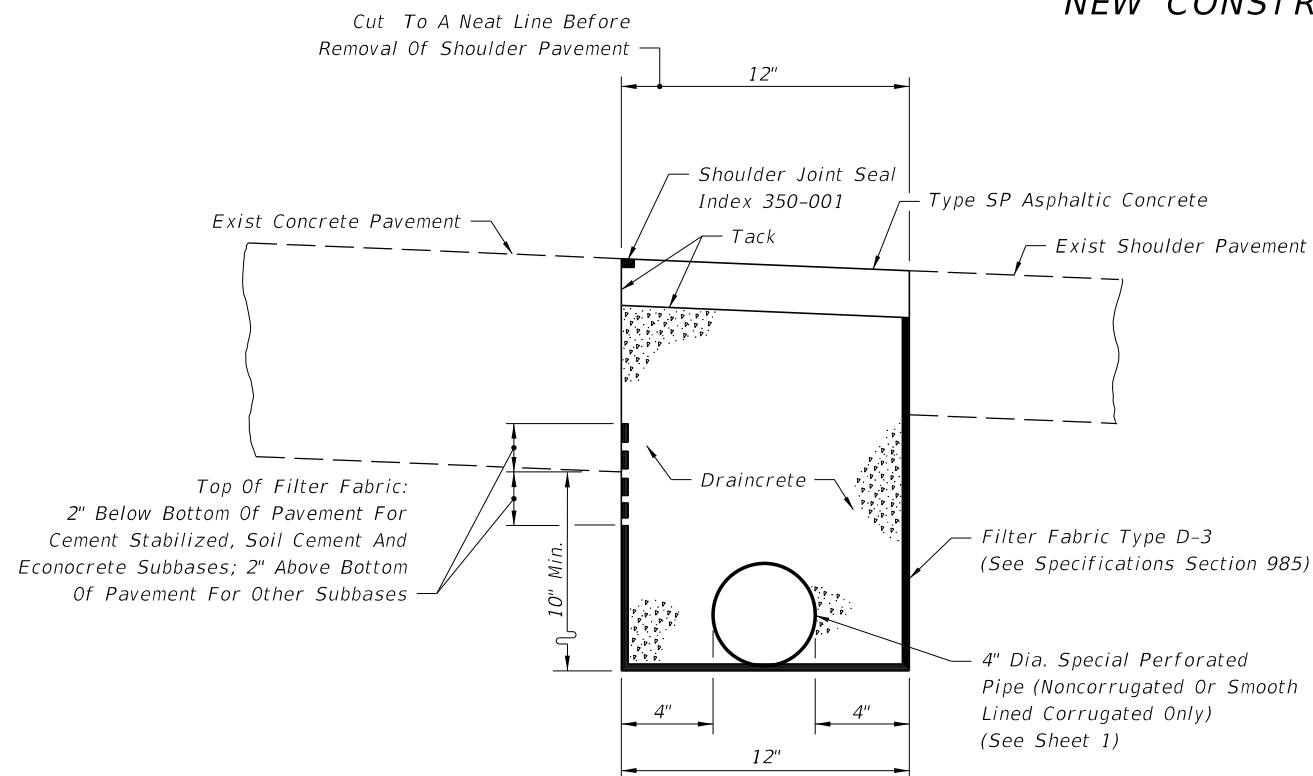

REHABILITATION
DRAINCRETE SUBDRAINAGE

NOTES FOR DRAINCRETE
PAVEMENT SUBDRAINAGE

1. The edgdrain sections for DRAINCRETE SUBDRAINAGE are applicable to pavement construction identified as RIGID PAVEMENT on Index 120-001.
2. The contractor shall confine the construction of draincrete edgdrain to an area in which the entire operation can be carried out in five (5) work days, unless another construction period is called for in the plans, with sufficient time allowed for the draincrete to set before placement of pavement.

METHOD OF PAYMENT

NEW CONSTRUCTION:

1. The contract unit price for Edgdrain (Draincrete) LF shall be full compensation for trench excavation, disposal of excess material, filter fabric, draincrete edgdrain pipe and fittings and draincrete.

Payment for outlet pipe shall be in accordance with General Note 9, Sheet 1 of 4.

FOR REHABILITATION:

1. The contract unit price for Edgdrain (Draincrete) LF, shall be full compensation for removal of existing shoulder pavement, trench excavation, disposal of excess materials, filter fabric, draincrete edgdrain pipe and fittings, and draincrete, necessary for edgdrain construction.

Payment for outlet pipe shall be in accordance with General Note 9, Sheet 1 of 4.

Shoulder pavement shall be paid for under the contract unit price for Type SP, Asphaltic Concrete.

Shoulder joint seal shall be paid for under the contract unit price for Pavement Joint, LF.

10/30/2018 8:50:32 AM

LAST REVISION 11/01/17	DESCRIPTION:		FY 2019-20 STANDARD PLANS	CONCRETE PAVEMENT SUBDRAINAGE	INDEX	SHEET
					446-001	2 of 4

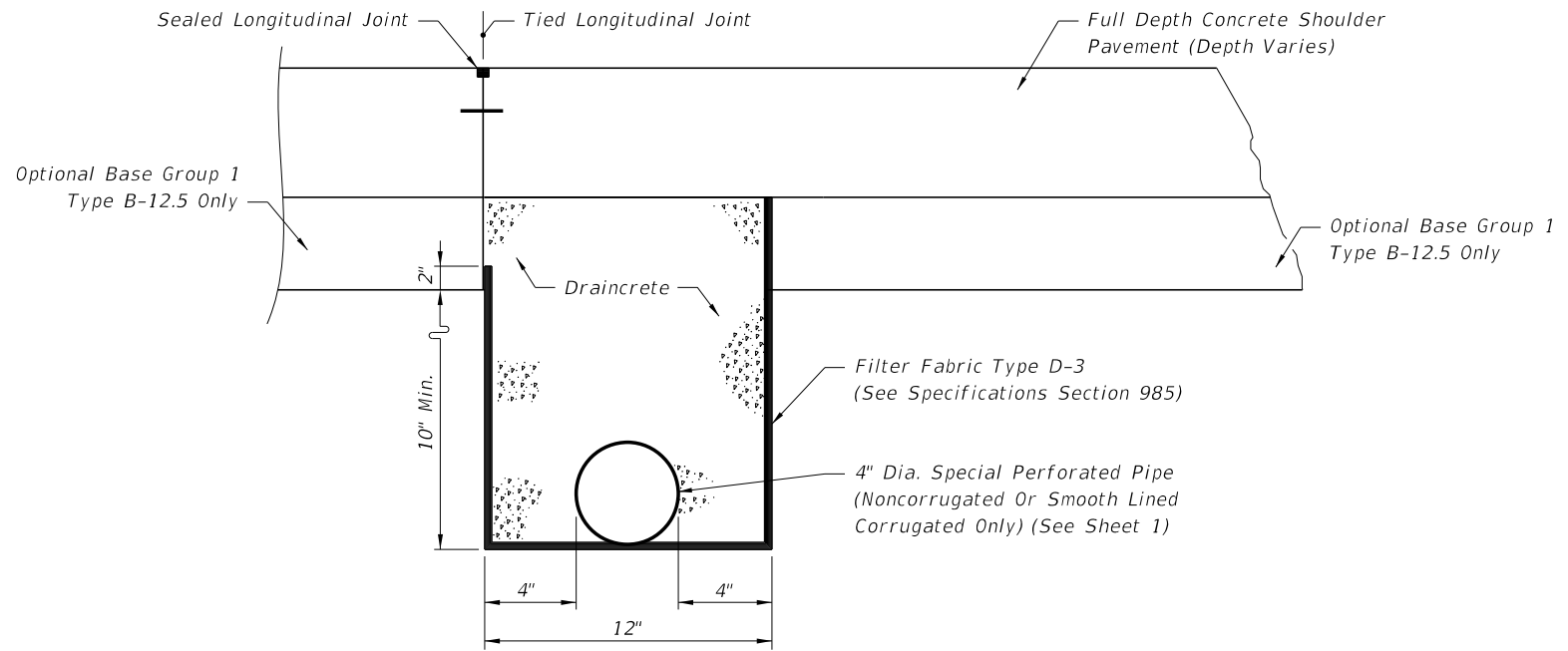

CONCRETE TRAVEL LANES,
SHOULDERS, AND AUXILIARY PAVEMENT

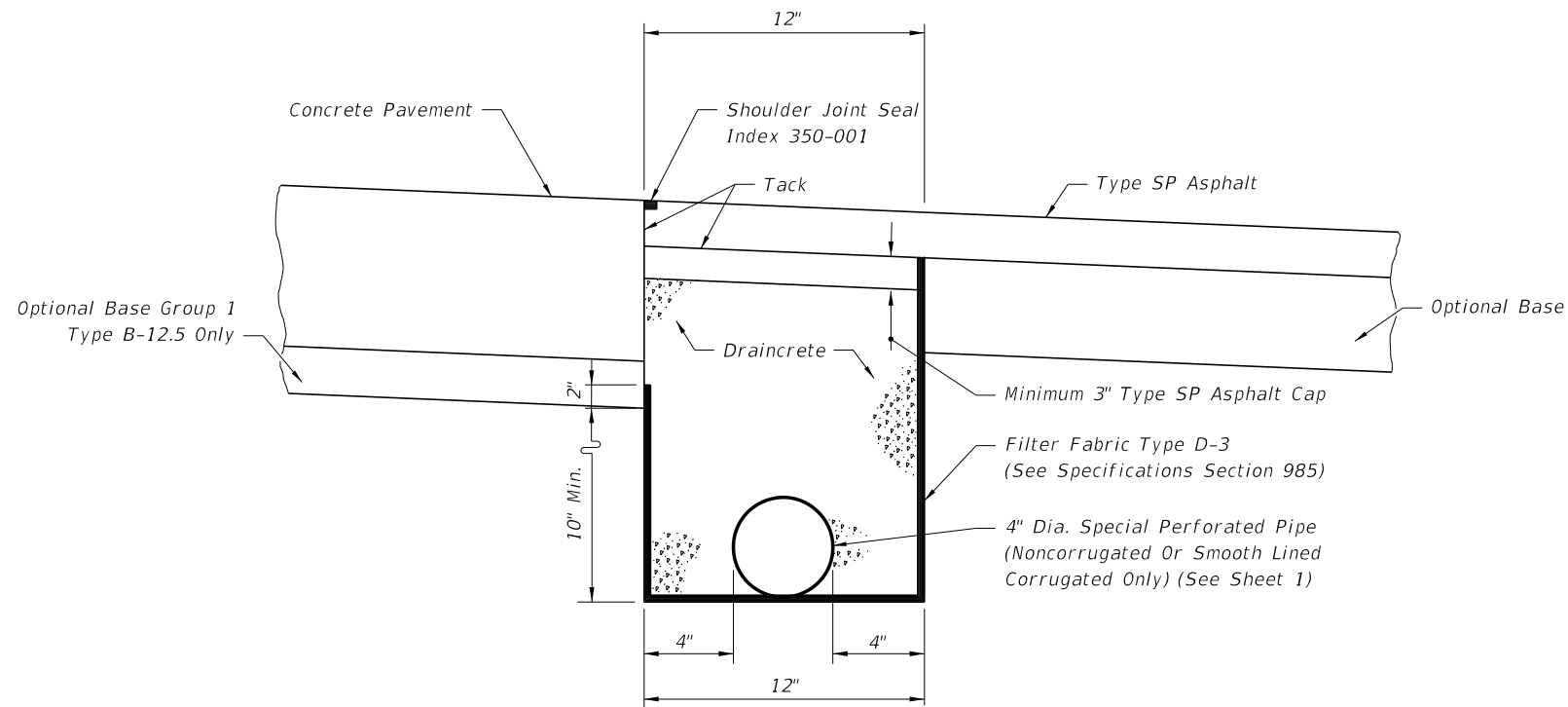

ASPHALT SHOULDERS

ASPHALT BASE SUBDRAINAGE

NOTES FOR DRAINCRETE
PAVEMENT SUBDRAINAGE

1. The edgedrain sections for DRAINCRETE SUBDRAINAGE are applicable to pavement construction identified as RIGID PAVEMENT on Index 120-001.
2. The contractor shall confine the construction of draincrete edgedrain to an area in which the entire operation can be carried out in five (5) work days, unless another construction period is called for in the plans, with sufficient time allowed for the draincrete to set before placement of pavement.

METHOD OF PAYMENT

NEW CONSTRUCTION:

1. The contract unit price for Edgedrain (Draincrete) LF shall be full compensation for trench excavation, disposal of excess material, filter fabric, draincrete edgedrain pipe and fittings and draincrete.
Payment for outlet pipe shall be in accordance with General Note 9, Sheet 1 of 4.
2. Type B-12.5 shall be paid for under the contract unit price for Optional Base.
3. Shoulder pavement shall be paid for under the contract unit price for Type SP, Asphaltic Concrete.

10/30/2018 8:50:36 AM

LAST REVISION 11/01/17	REVISION	DESCRIPTION:	 FY 2019-20 STANDARD PLANS	CONCRETE PAVEMENT SUBDRAINAGE	INDEX 446-001	SHEET 3 of 4
---------------------------	----------	--------------	-----------------------------------------------------------------------------------------------------------------------	-------------------------------	------------------	-----------------

GENERAL NOTES FOR TREATED PERMEABLE BASE EDGEDRAIN

NEW CONSTRUCTION

1. The contractor shall confine the construction of edgedrain to an area in which the entire operation can be carried out in (5) work days, unless another construction period is called for the plans.

METHOD OF PAYMENT

NEW CONSTRUCTION

1. Payment shall be full compensation for trench excavation, disposal of excess materials, filter fabric, pipe and fittings, necessary for concrete pavement subdrainage construction. Payment shall be included in the cost for Asphalt Treated Permeable Base, CY or Cement Treated Permeable Base, CY.

Payment for outlet pipe shall be in accordance with General Note 9, Sheet 1 of 4.

2. Shoulder pavement and separation layer shall be paid for under the contract unit price for Type SP, Asphaltic Concrete.

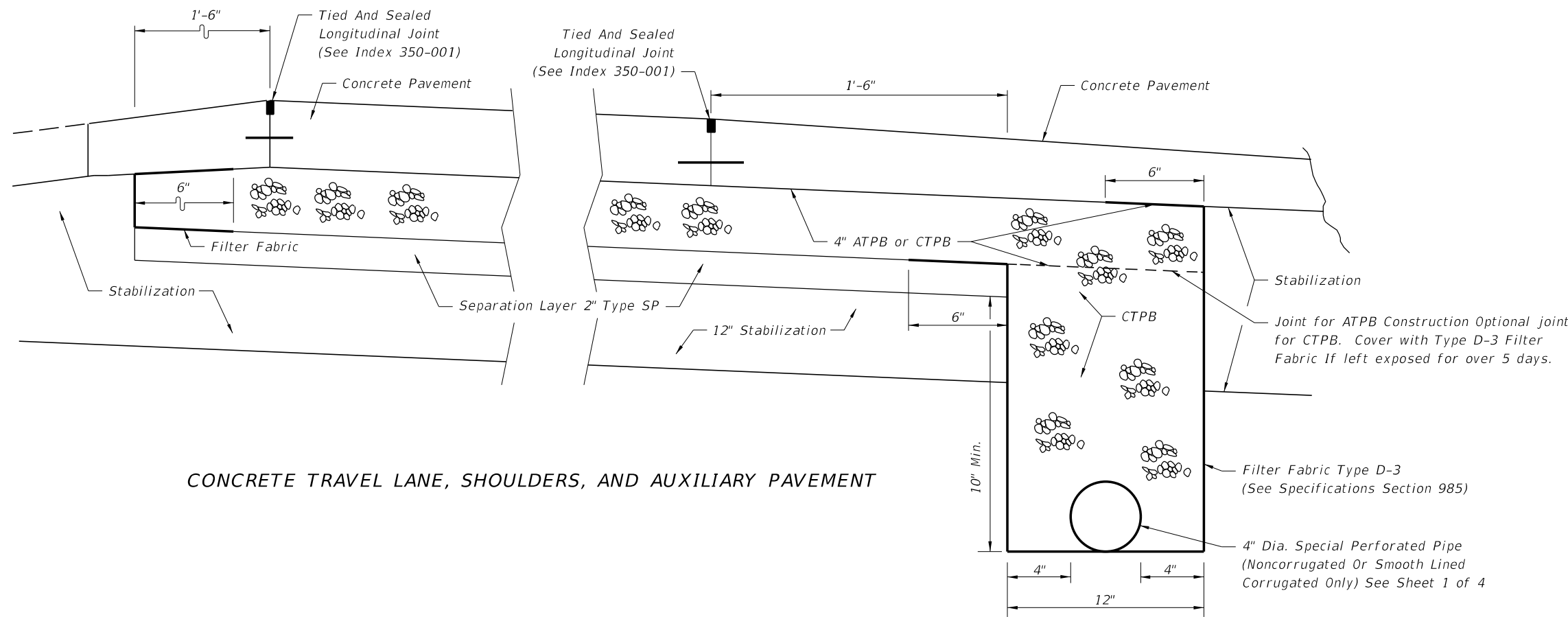

CONCRETE TRAVEL LANE, SHOULDERS, AND AUXILIARY PAVEMENT

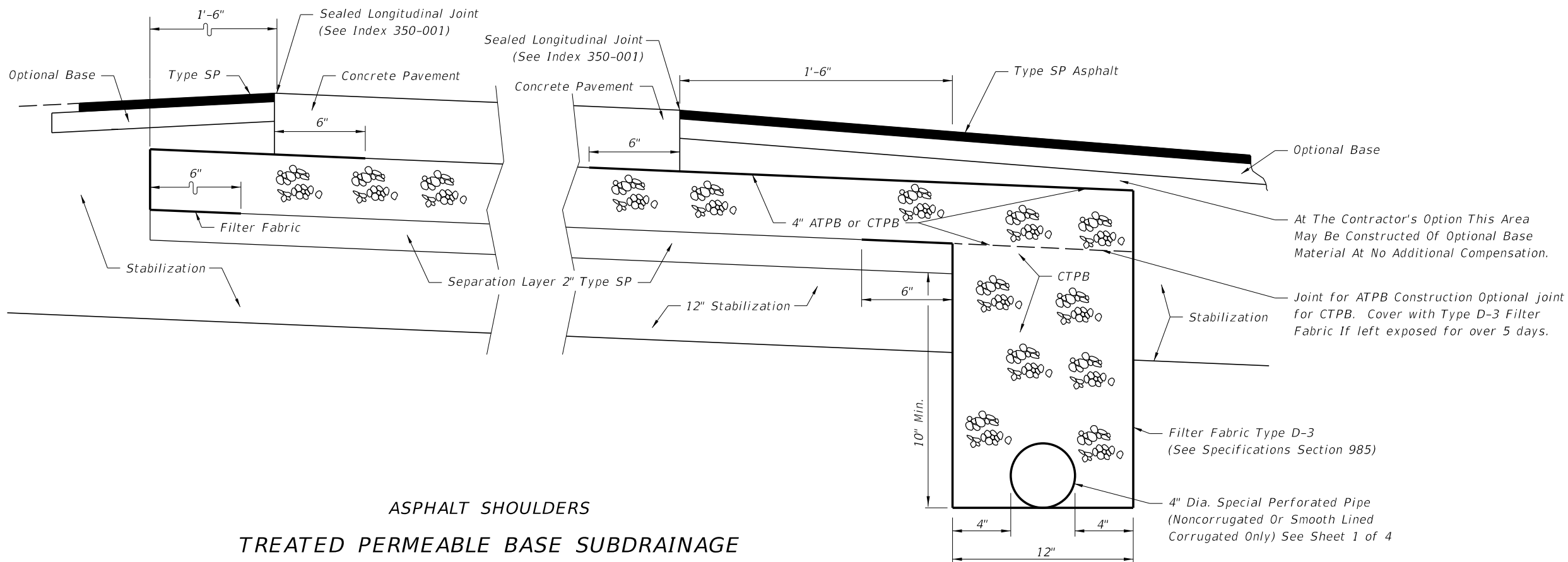

**ASPHALT SHOULDERS
TREATED PERMEABLE BASE SUBDRAINAGE**

10/30/2018 8:50:39 AM

LAST REVISION 11/01/17	REVISION	DESCRIPTION:	 FY 2019-20 STANDARD PLANS	CONCRETE PAVEMENT SUBDRAINAGE	INDEX 446-001	SHEET 4 of 4
---------------------------	----------	--------------	-------------------------------------------------------------------------------------------------------------------------------	--------------------------------------	-------------------------	------------------------