

ALTERNATING SKIP LINE

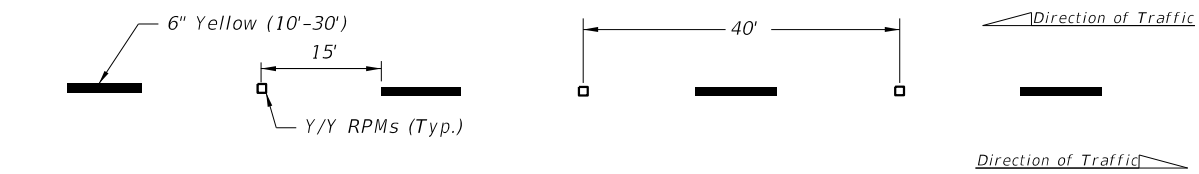

SKIP LINE

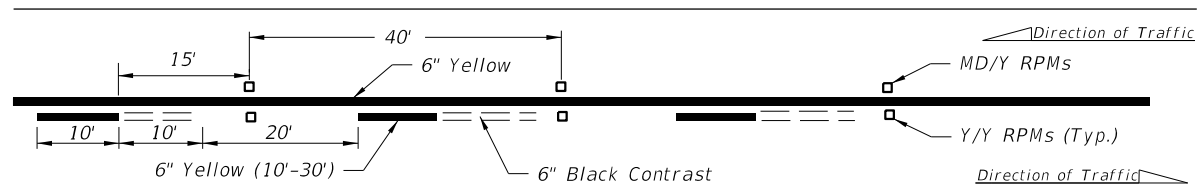

SOLID LINE WITH ALTERNATING SKIP

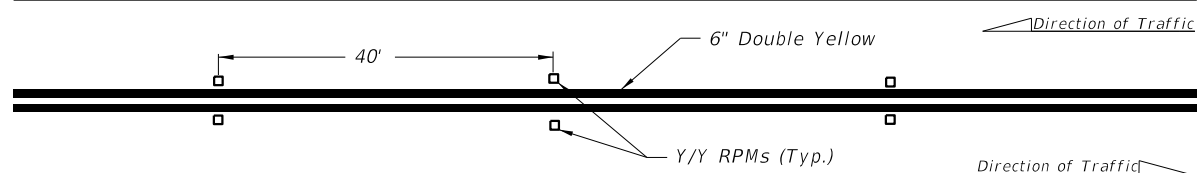

DOUBLE SOLID LINE

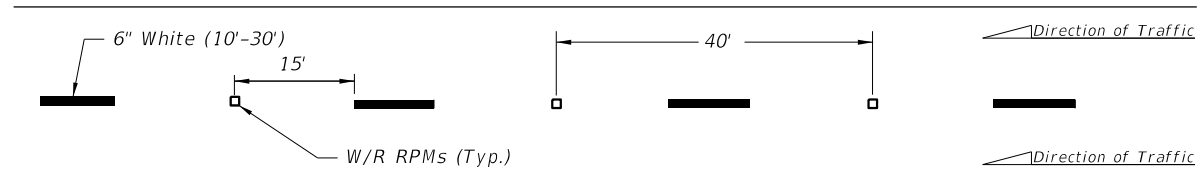

MULTILANE

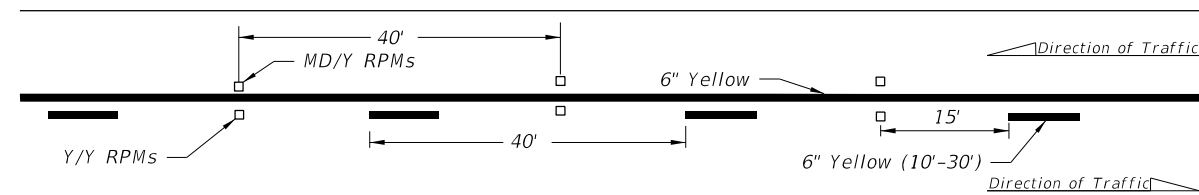

SOLID LINE WITH SKIP

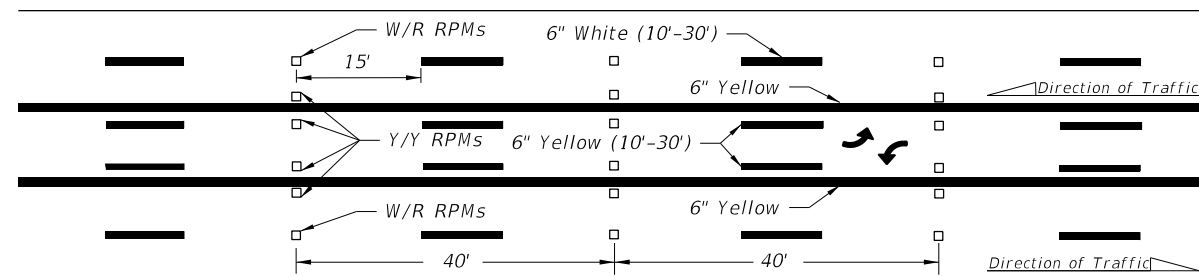

SKIP LINE WITH TWO-WAY LEFT TURN LANE

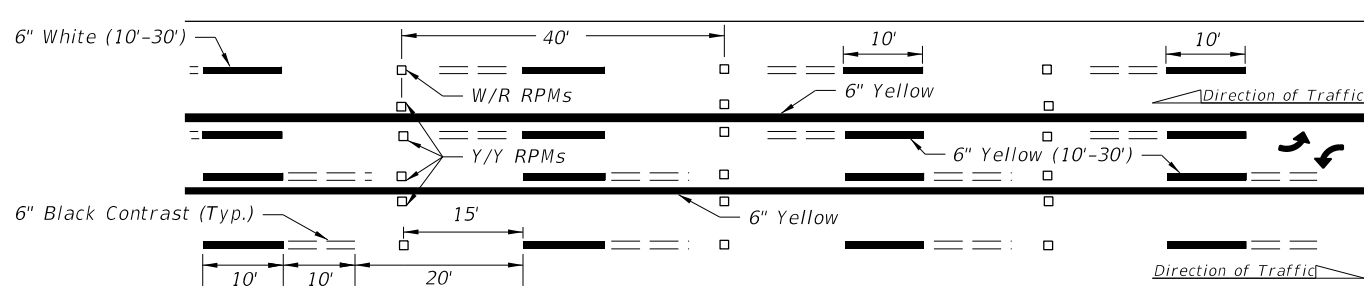

ALTERNATING SKIP LINE WITH TWO-WAY LEFT TURN LANE

GENERAL NOTES:

1. Offset all RPMs 1" from solid longitudinal lines unless otherwise noted or shown.
2. Spacing may be reduced for sharp curves if required.
3. For placement of RPMs on ramps, see Index 711-003.
4. Make the traffic face of the RPM the same color as the pavement marking that it is supplementing.

LEGEND:

- B/C = BACK OF CURB
- EOP = EDGE OF PAVEMENT
- RPM = RAISED PAVEMENT MARKER
- W/R = WHITE/RED RPM
- Y/Y = YELLOW/YELLOW RPM
- Y/R = YELLOW/RED RPM
- MD/Y = MONO-DIRECTIONAL YELLOW RPM

10/24/2018 3:32:42 PM

LAST REVISION 11/01/18	REVISION	DESCRIPTION:		FY 2019-20 STANDARD PLANS	TYPICAL PLACEMENT OF RAISED PAVEMENT MARKERS	INDEX 706-001	SHEET 1 of 6
---------------------------	----------	--------------	--	------------------------------	---	------------------	-----------------

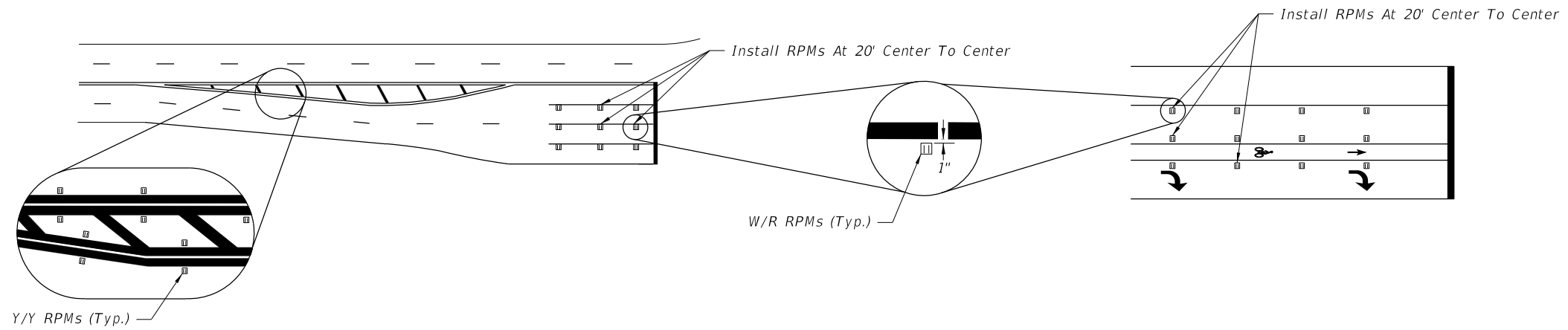

RPM PLACEMENT AT INTERSECTIONS

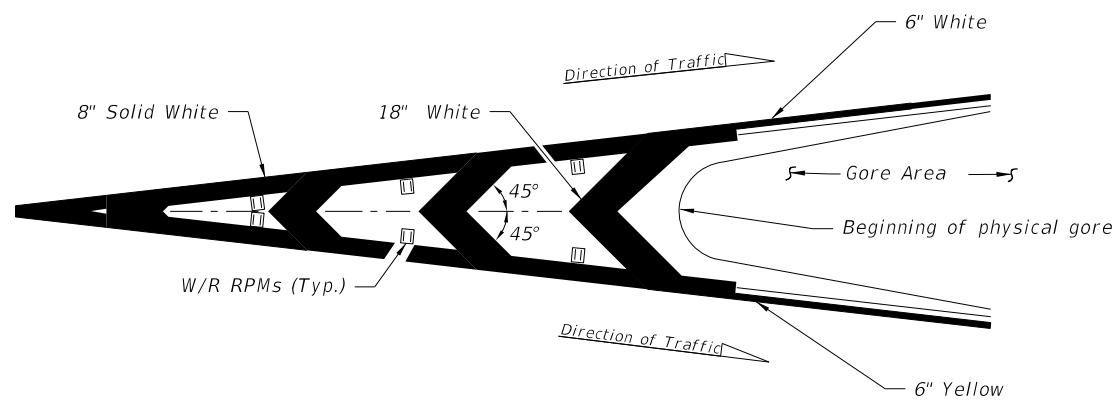

RPM PLACEMENT AT TRAFFIC CHANNELIZATION AT GORE
(Traffic Flows In Same Direction)

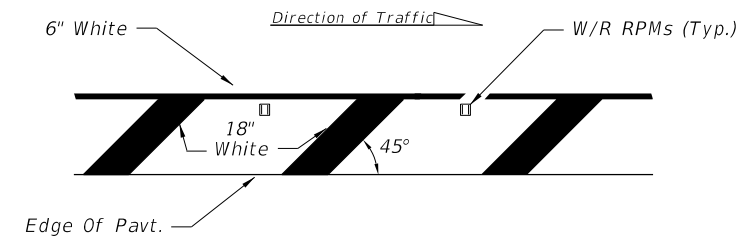

Right side of the roadway shown. For the left side of roadway, the pavement marking is yellow and oriented opposite hand.

RPM PLACEMENT AT ROADSIDE CROSSHATCHING

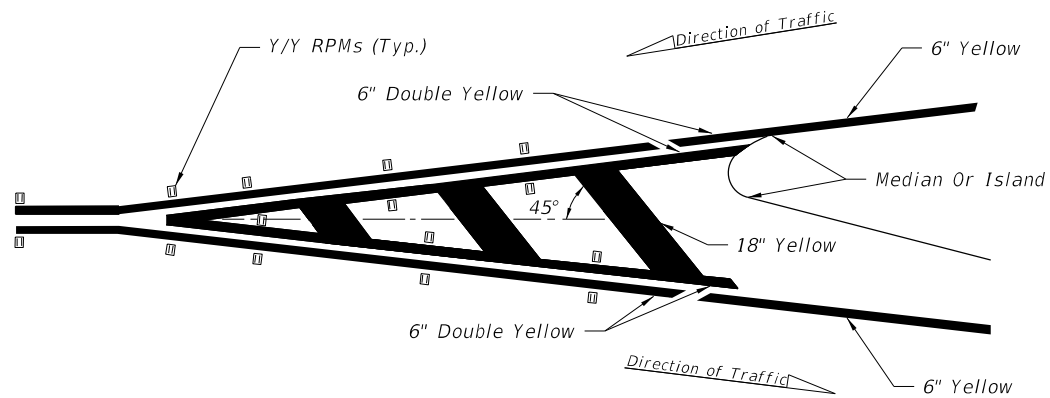

RPM PLACEMENT AT TRAFFIC SEPARATION
(Traffic Flows In Opposite Direction)

NOTE:

1. Center the Raised Pavement Markers between chevrons and crosshatching.

LEGEND:

- B/C = BACK OF CURB
- EOP = EDGE OF PAVEMENT
- RPM = RAISED PAVEMENT MARKER
- W/R = WHITE/RED RPM
- Y/Y = YELLOW/YELLOW RPM
- Y/R = YELLOW/RED RPM
- MD/Y = MONO-DIRECTIONAL YELLOW RPM

10/24/2018 3:32:42 PM

LAST REVISION 11/01/18	REVISION	DESCRIPTION:	 FY 2019-20 STANDARD PLANS	TYPICAL PLACEMENT OF RAISED PAVEMENT MARKERS	INDEX 706-001	SHEET 2 of 6
---------------------------	----------	--------------	---	---	------------------	-----------------

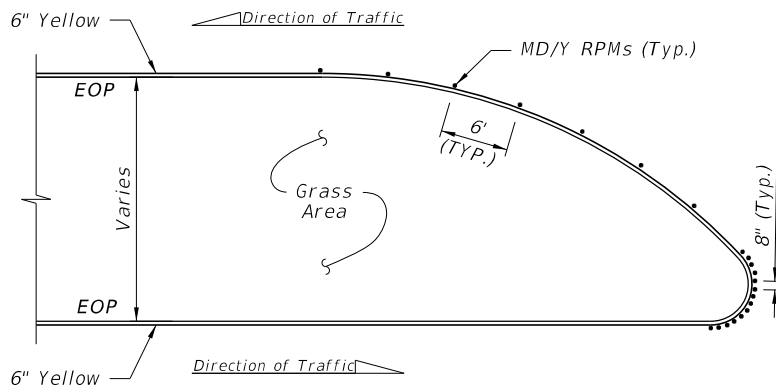

DETAIL "A"

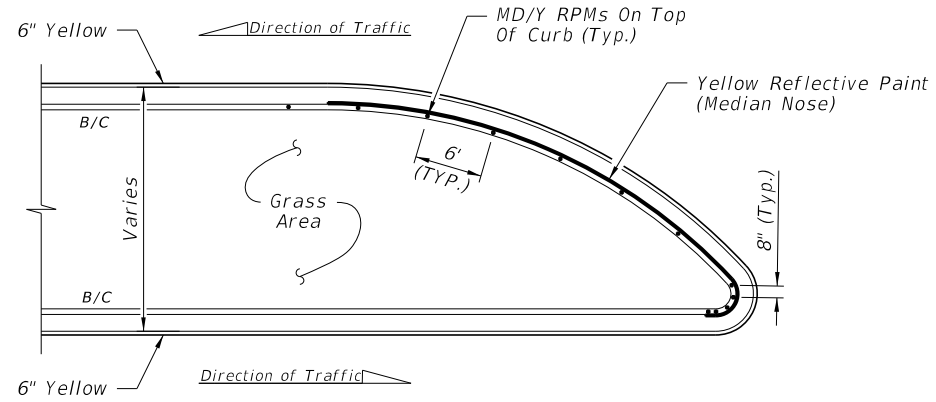

DETAIL "D"

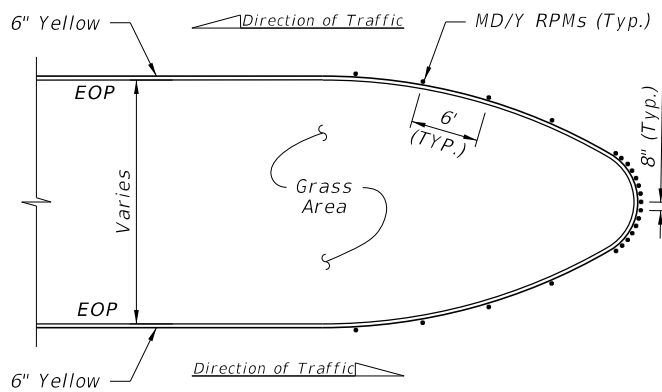
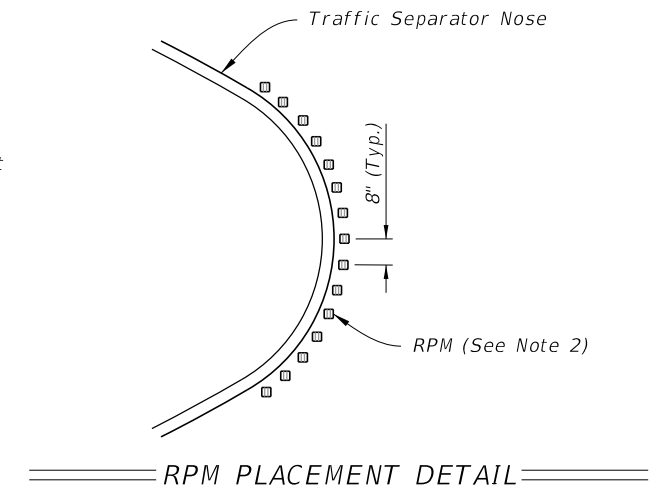

DETAIL "B"

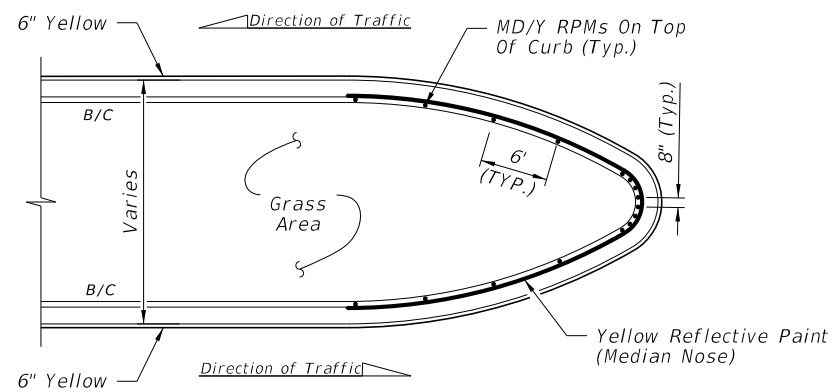

DETAIL "E"

POSTED SPEED LIMIT MPH	"Y" FEET
30 OR LESS	10
35	20
40	20
45	30
50 OR MORE	40

LEGEND:

- B/C = BACK OF CURB
- EOP = EDGE OF PAVEMENT
- RPM = RAISED PAVEMENT MARKER
- W/R = WHITE/RED RPM
- Y/Y = YELLOW/YELLOW RPM
- Y/R = YELLOW/RED RPM
- MD/Y = MONO-DIRECTIONAL YELLOW RPM

NOTES:

1. For Type "E" Curb, install RPMs along the pavement edge marking using the same spacing shown.
2. Orient traffic faces of RPMs in curb median radii to be parallel to direction of travel lanes.

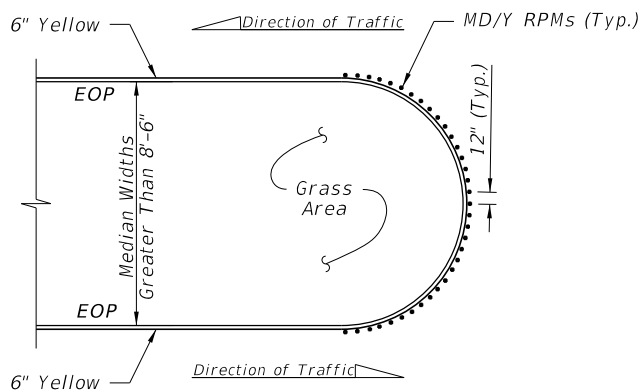

DETAIL "C"

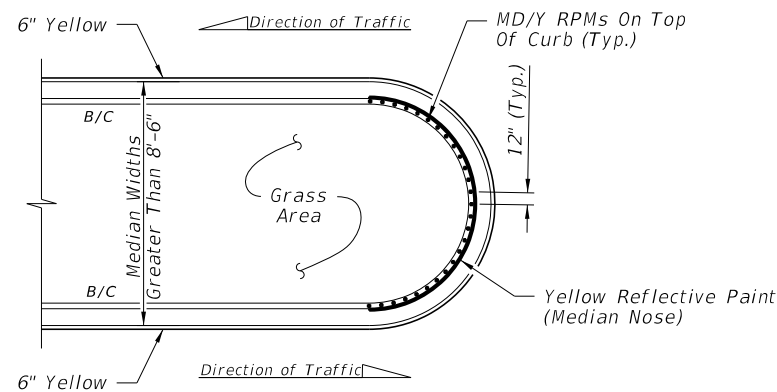

DETAIL "F"

FLUSH MEDIAN OPENINGS

TYPE "D" OR "F" CURB

RPM PLACEMENT AT MEDIAN OPENINGS
(When called for in the Plans)

12/11/2018 11:53:55 AM

LAST REVISION	DESCRIPTION:
11/01/18	



FY 2019-20
STANDARD PLANS

TYPICAL PLACEMENT OF
RAISED PAVEMENT MARKERS

INDEX
706-001

SHEET
3 of 6

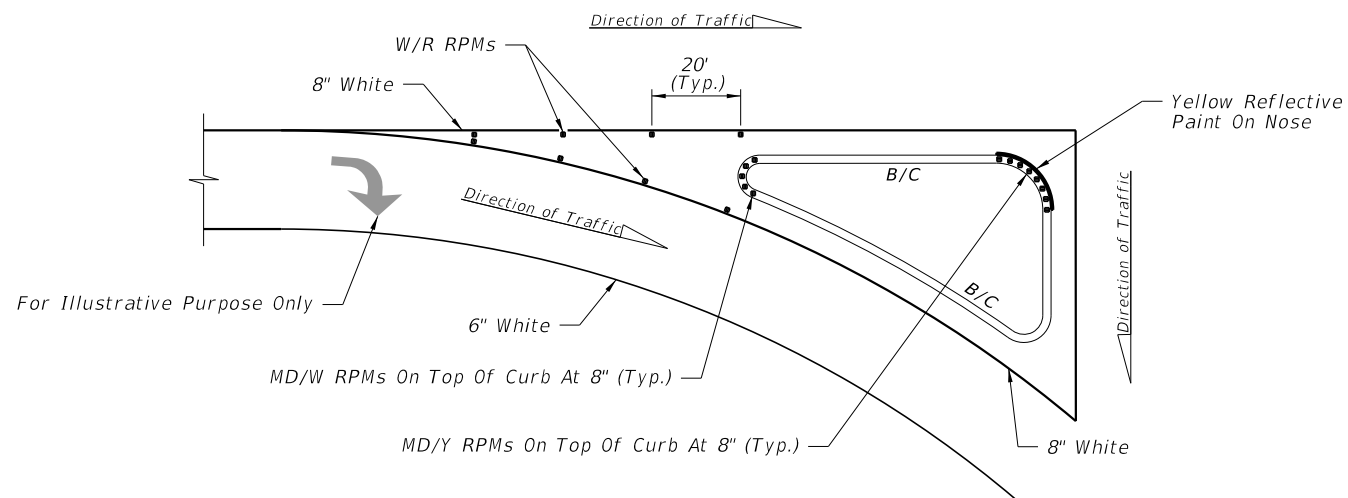

DETAIL "G"

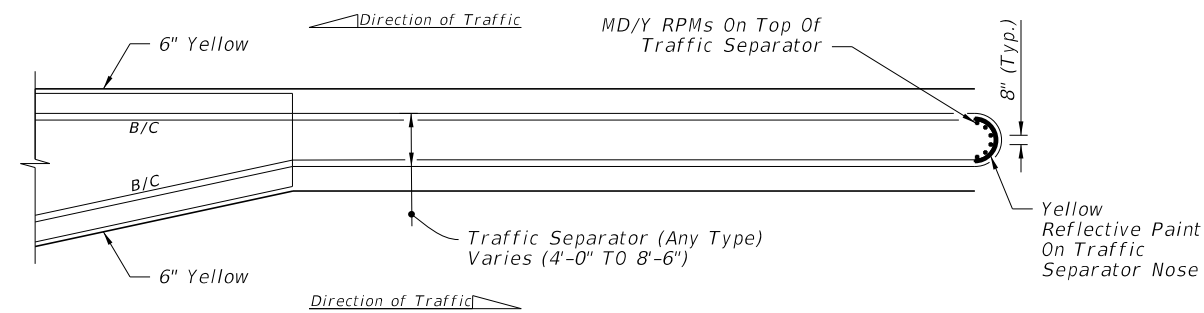

DETAIL "J"

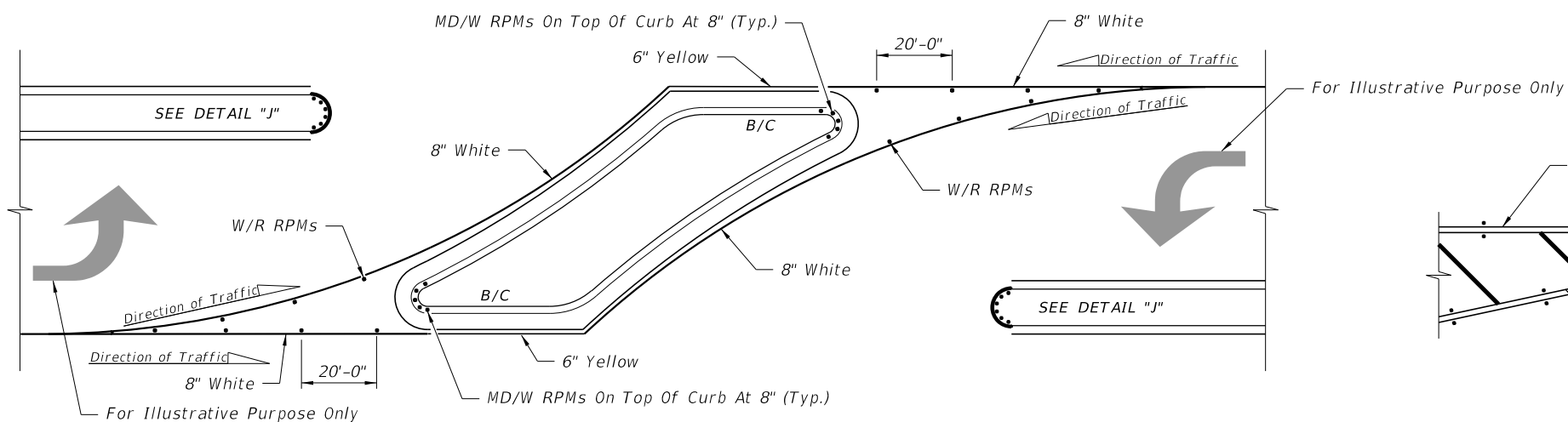

DETAIL "H"

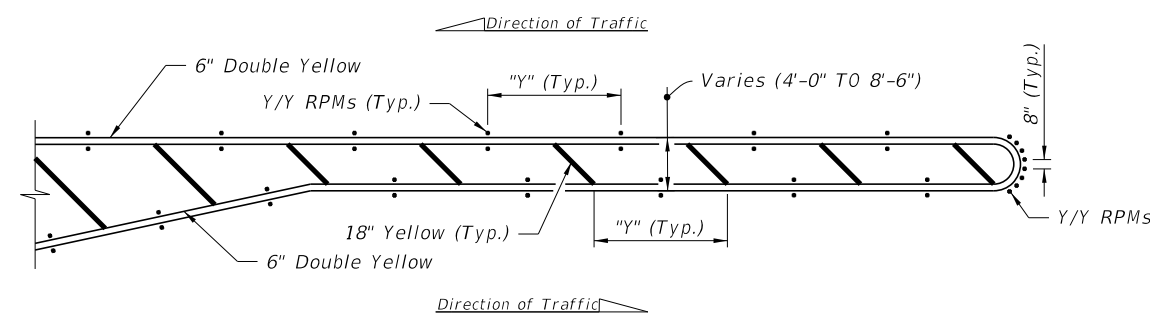

DETAIL "K"

RPM PLACEMENT AT ISLANDS
(When called for in the Plans)

RPM PLACEMENT AT TRAFFIC SEPARATORS
(When called for in the Plans)

POSTED SPEED LIMIT MPH	"y" FEET
30 OR LESS	10
35	20
40	20
45	30
50 OR MORE	40

NOTES:

- For Type "E" Curb install RPMs along the pavement edge marking using the same spacing shown.
- Orient traffic faces of RPMs in median radii to be parallel to direction of travel lanes.

LEGEND:

- B/C = BACK OF CURB
- EOP = EDGE OF PAVEMENT
- RPM = RAISED PAVEMENT MARKER
- W/R = WHITE/RED RPM
- Y/Y = YELLOW/YELLOW RPM
- Y/R = YELLOW/RED RPM
- MD/Y = MONO-DIRECTIONAL YELLOW RPM
- MD/W = MONO-DIRECTIONAL WHITE RPM

10/24/2018 3:32:43 PM

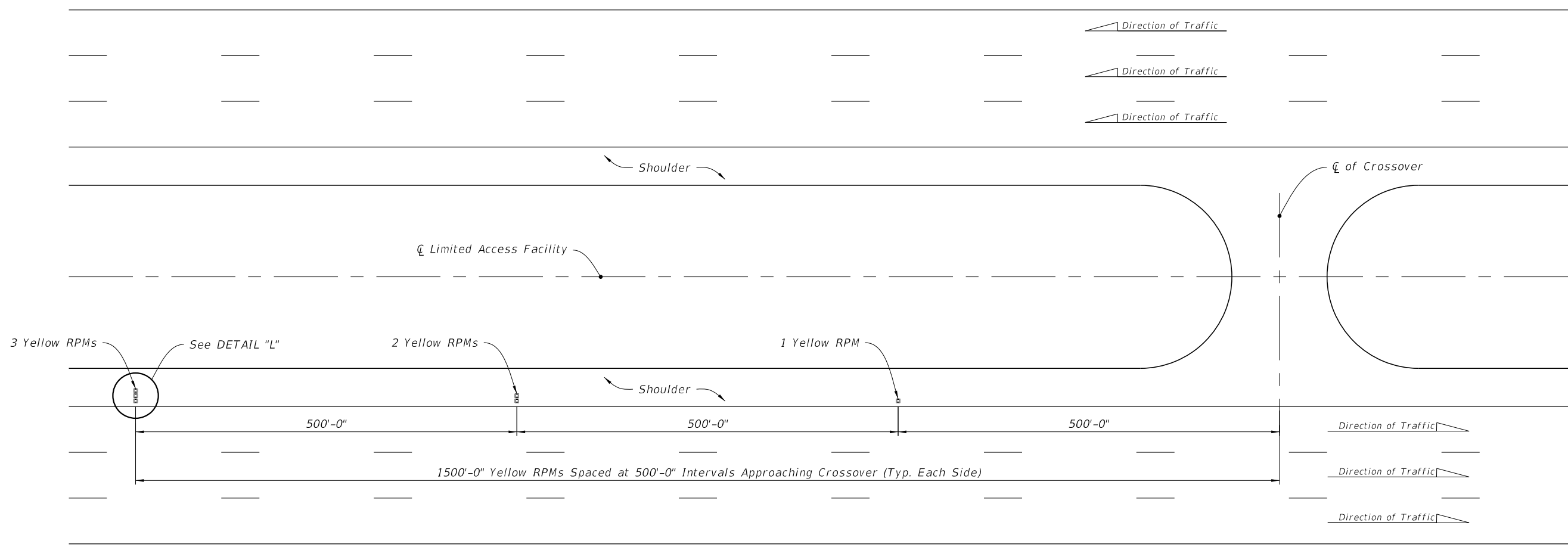

RPM PLACEMENT FOR CROSSOVERS ON LIMITED ACCESS ROADWAYS

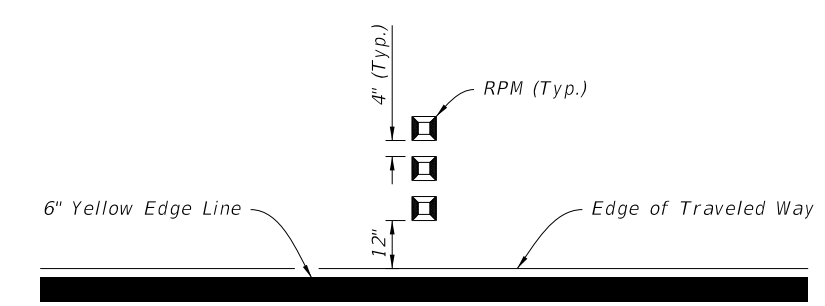

DETAIL "L"

10/24/2018 3:32:44 PM

LAST REVISION 11/01/18	DESCRIPTION:	 FY 2019-20 STANDARD PLANS	TYPICAL PLACEMENT OF RAISED PAVEMENT MARKERS	INDEX 706-001	SHEET 5 of 6
---------------------------	--------------	---	---	------------------	-----------------

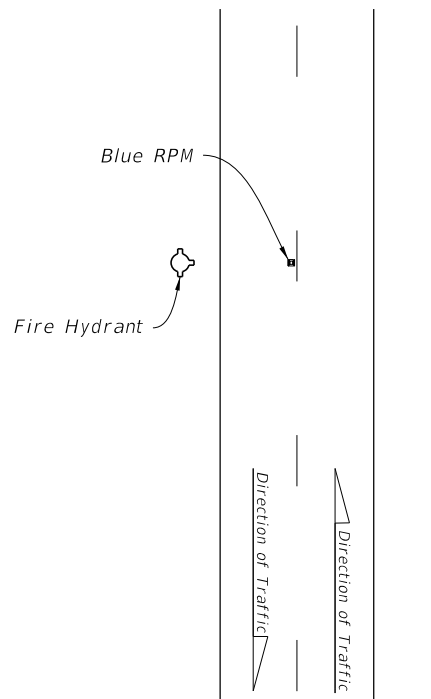

TWO-LANE ROADWAY

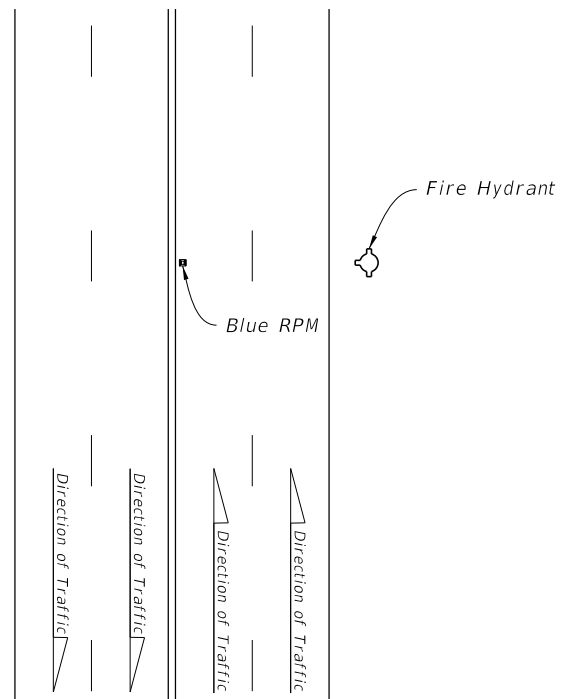

MULTILANE ROADWAY

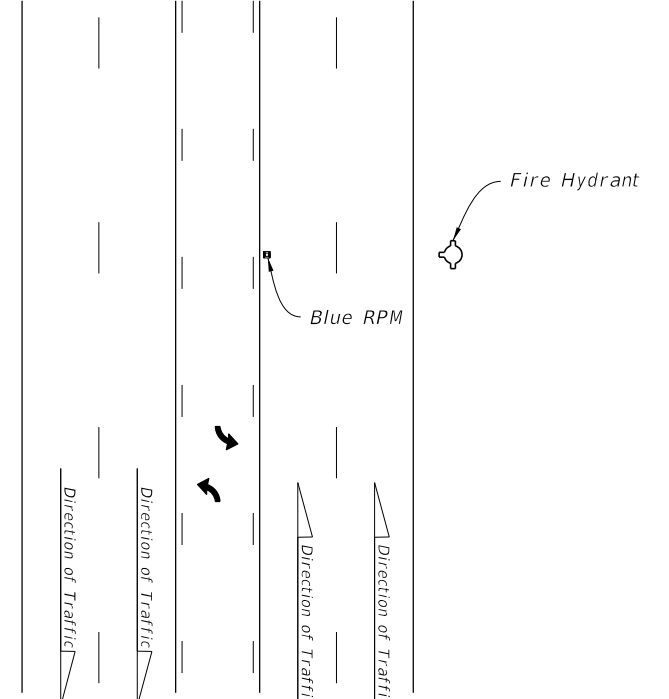

MULTILANE ROADWAY WITH TURN LANE

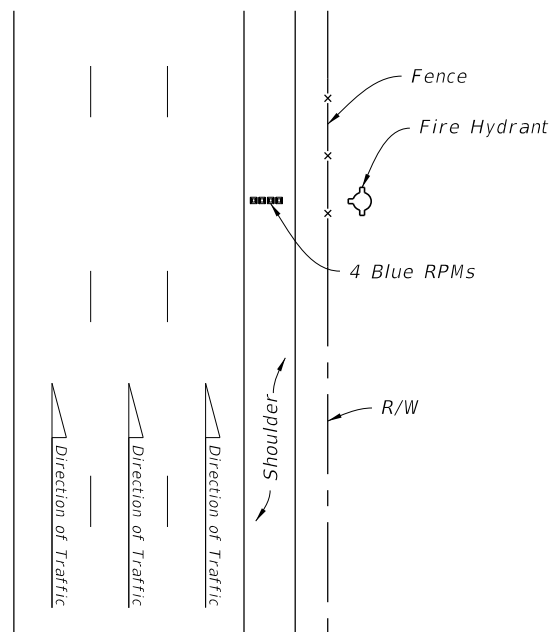

LIMITED ACCESS ROADWAY

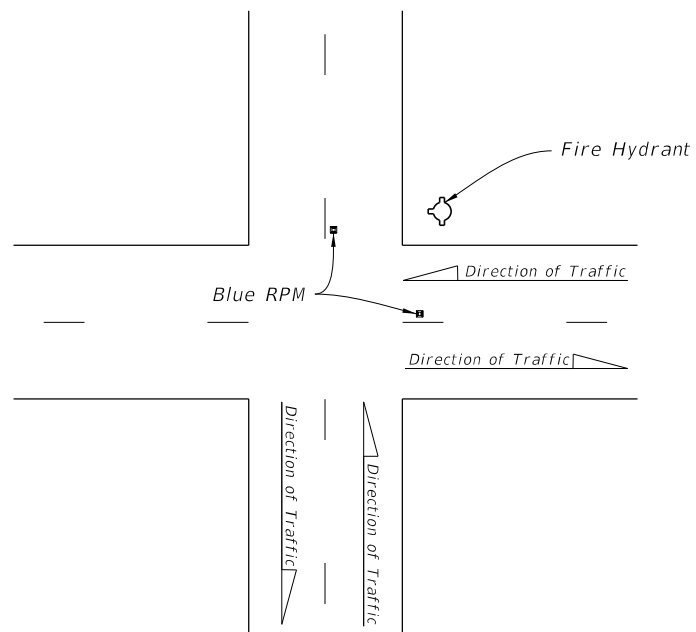

TWO-LANE ROADWAY AT INTERSECTION

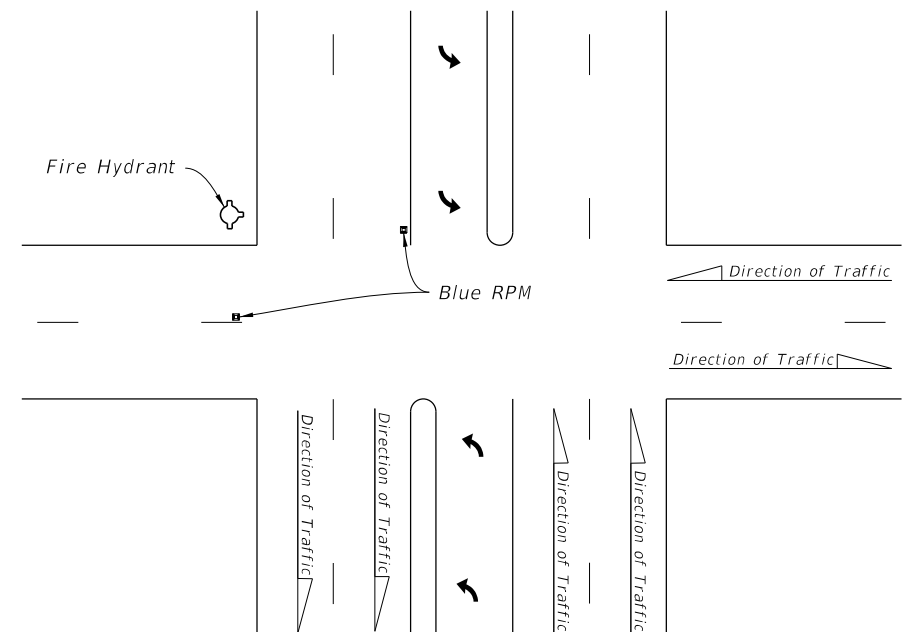

MULTILANE ROADWAY AT INTERSECTION

BLUE RPM PLACEMENT

10/24/2018 3:32:44 PM

LAST REVISION 11/01/18	REVISION DESCRIPTION:	 FY 2019-20 STANDARD PLANS	TYPICAL PLACEMENT OF RAISED PAVEMENT MARKERS	INDEX 706-001	SHEET 6 of 6
---------------------------	--------------------------	--	---	------------------	-----------------