

SIDE VIEW

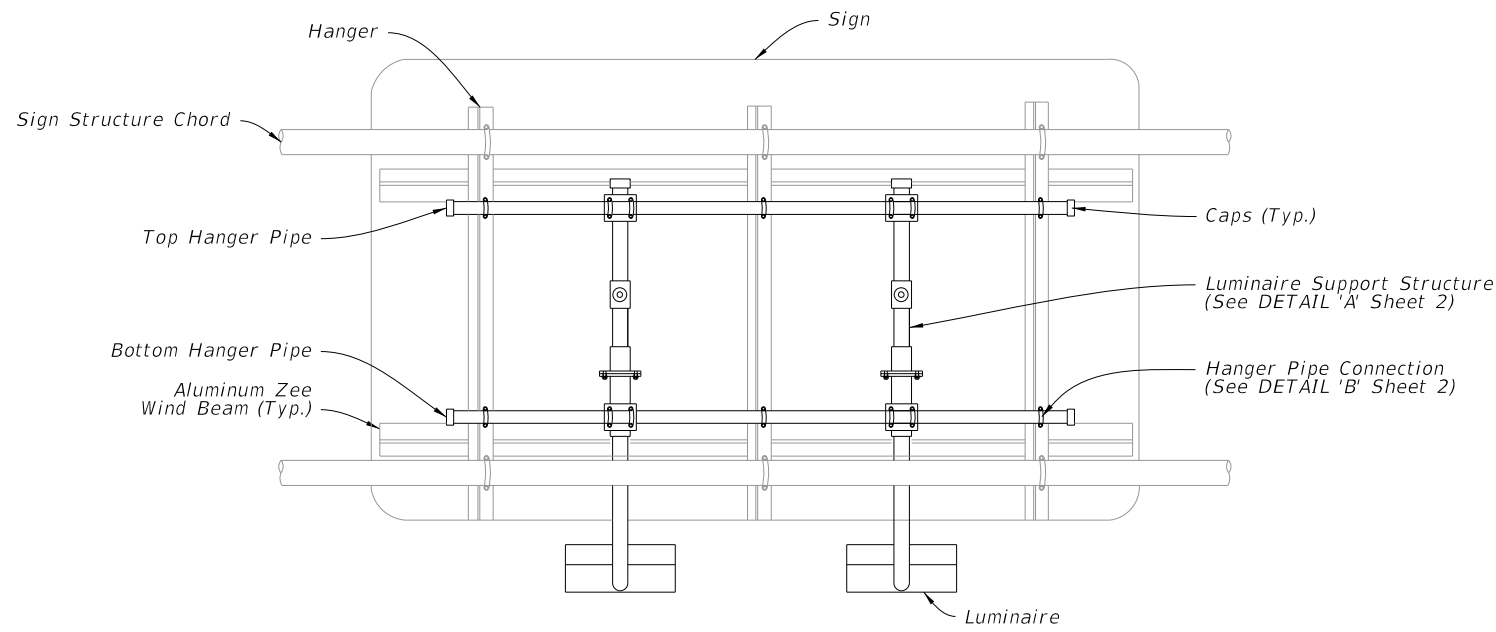

BACK VIEW

PLACEMENT OF SIGN LIGHTS

1. This Index details a bottom luminaire support structure. For signs requiring top luminaire support structures, the detail can be reversed.
2. Luminaire spacing and arm length is shown on Guide Sign Worksheet.
3. The Guide Sign Worksheet indicates the sign luminaire used for basis of design. The contractor may propose a different luminaire by submitting photometric calculations for each lighted sign for review by the Engineer.

SIGN LIGHTING INSTALLATION

Roadway Lighting included in contract:

1. Power for the sign lighting provided from the roadway lighting circuit.
2. Indicate sign location and a pull box location for connection to the sign lights in the lighting plans.
3. Lighting contractor installs pull box and loop 2' of lighting circuit conductors in the pull box for connection by the signing contractor.
4. Signing contractor furnishes and installs the Luminaires, Nema 3R enclosure, 30 amp breaker, conduit, conductors and all other electrical equipment necessary for connection to the lighting circuit.

Roadway Lighting not included in contract:

1. Signing plans include the pay item numbers to furnish and install conduit, conductors, ground rods, pull boxes and service point equipment.
2. Signing plans indicate the location of the service point equipment and circuit runs.
3. Signing contractor provides all electrical equipment necessary for connection of the sign lights.

9/19/2018 1:26:08 PM

LAST REVISION 11/01/17	REVISION	DESCRIPTION:	 FY 2019-20 STANDARD PLANS	EXTERNAL LIGHTING FOR SIGNS	INDEX 700-031	SHEET 1 of 2
---------------------------	----------	--------------	---	------------------------------------	-------------------------	------------------------

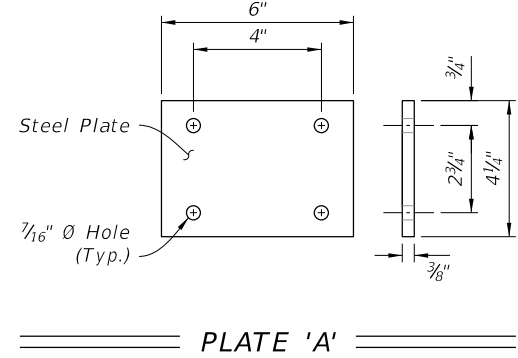
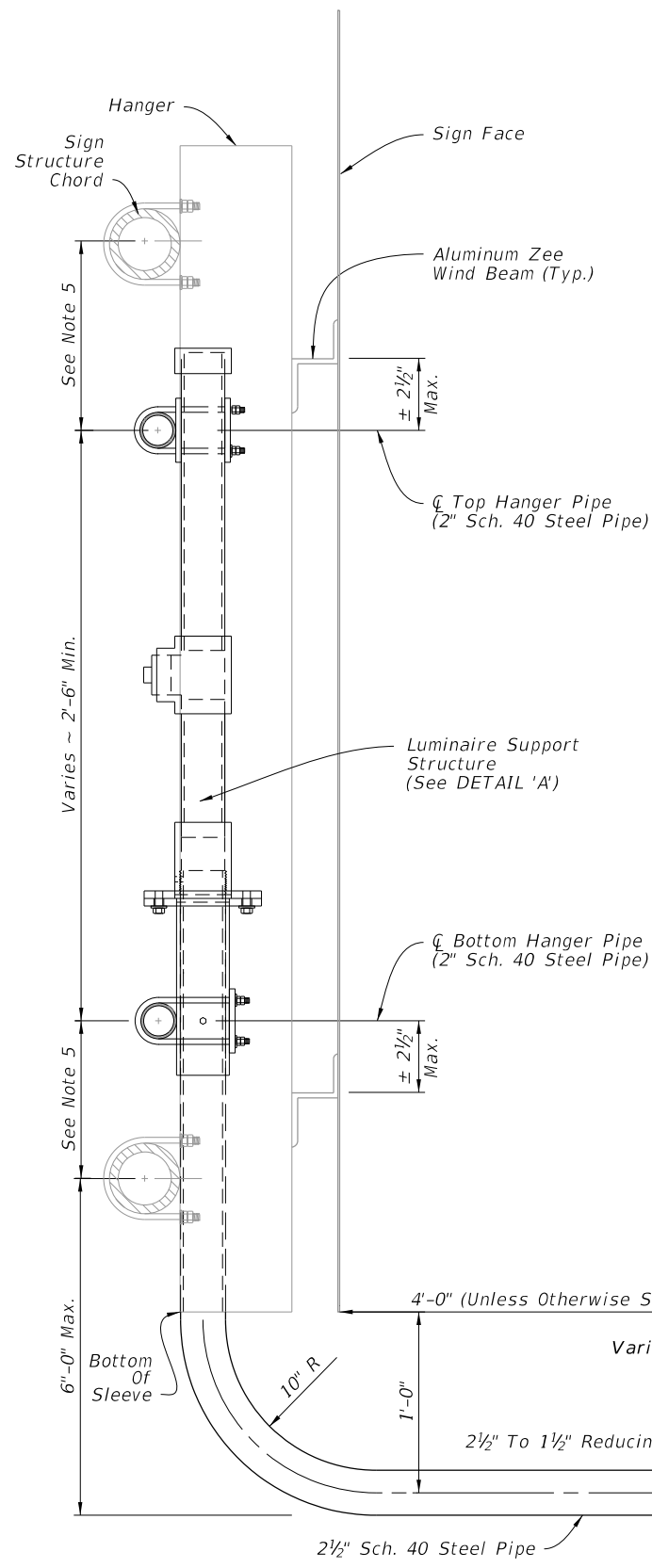

NOTES

1. Install hanger pipe to each vertical beam crossed with a 3/8" U-Bolt, lock washers and hex nuts. Cap both ends of the horizontal pipe.
2. Materials;
 - A. Steel Pipe: ASTM A53 (Grade A or B)
 - B. Steel Plate: ASTM A36
 - C. Bolts: ASTM A307
 - D. Hex Nuts: ASTM A563
 - E. Washers: ASTM F436
3. Coating: Hot-Dip Galvanize pipes, plates, structural shapes: ASTM A123, Fasteners and hardware: ASTM A153.
4. All pipe dimensions are NPS.
5. $\frac{\text{Chord O.D.} + 5"}{2}$ (Min.)

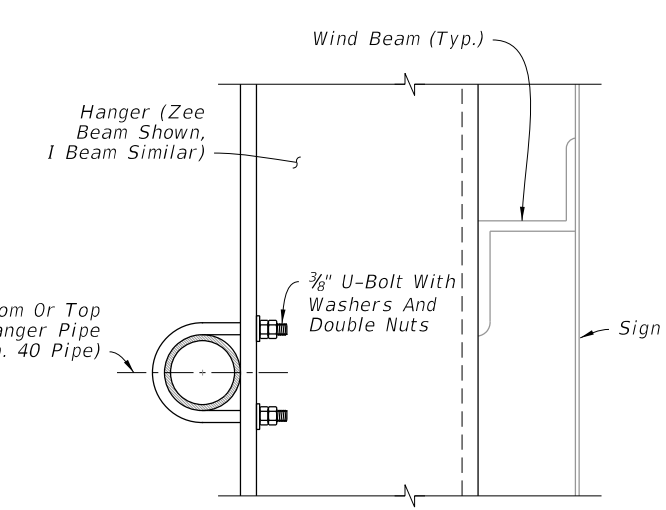
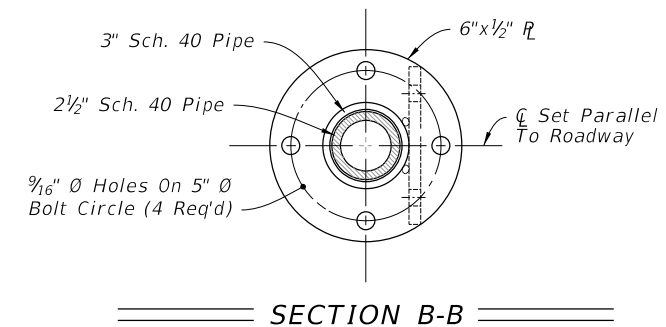
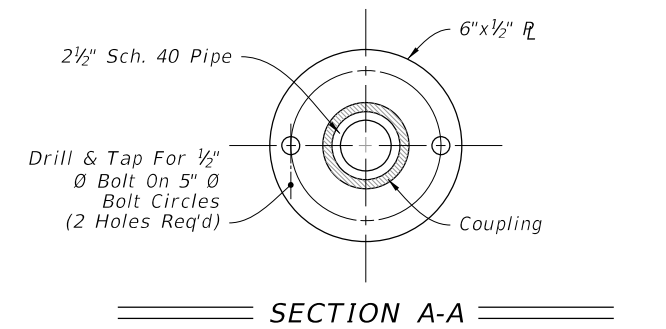
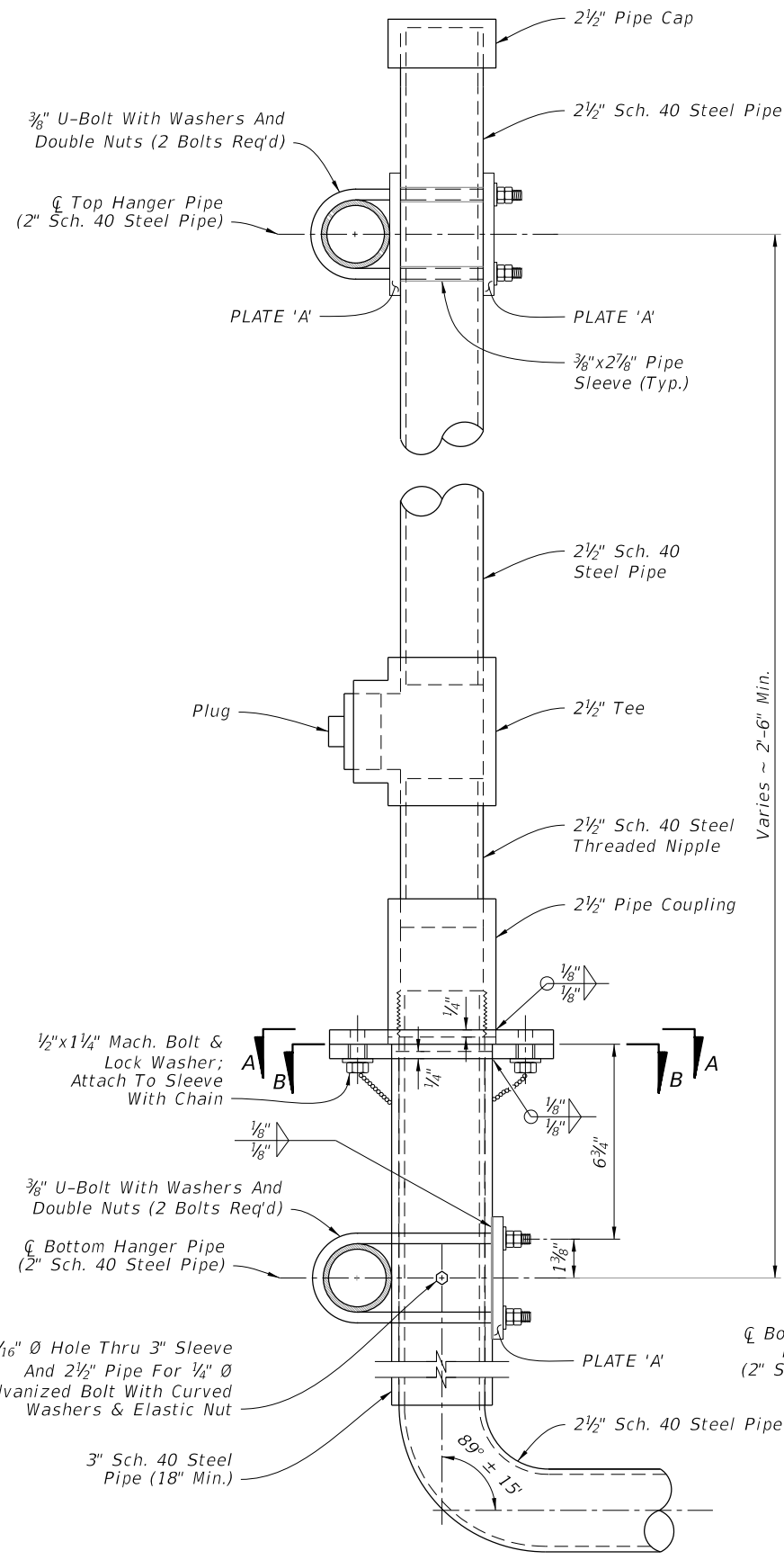

LUMINAIRE SUPPORT STRUCTURE

DETAIL 'A'
(Luminaire Support Structure)

DETAIL 'B'
(Hanger Pipe Connection)

9/19/2018 1:26:09 PM

LAST REVISION 11/01/17	DESCRIPTION:	 FY 2019-20 STANDARD PLANS	EXTERNAL LIGHTING FOR SIGNS	INDEX 700-031	SHEET 2 of 2
---------------------------	--------------	----------------------------------	------------------------------------	------------------	-----------------