

PLAN
 (Scheme 2 shown, other Schemes similar, Reinforcing Steel not shown for clarity)

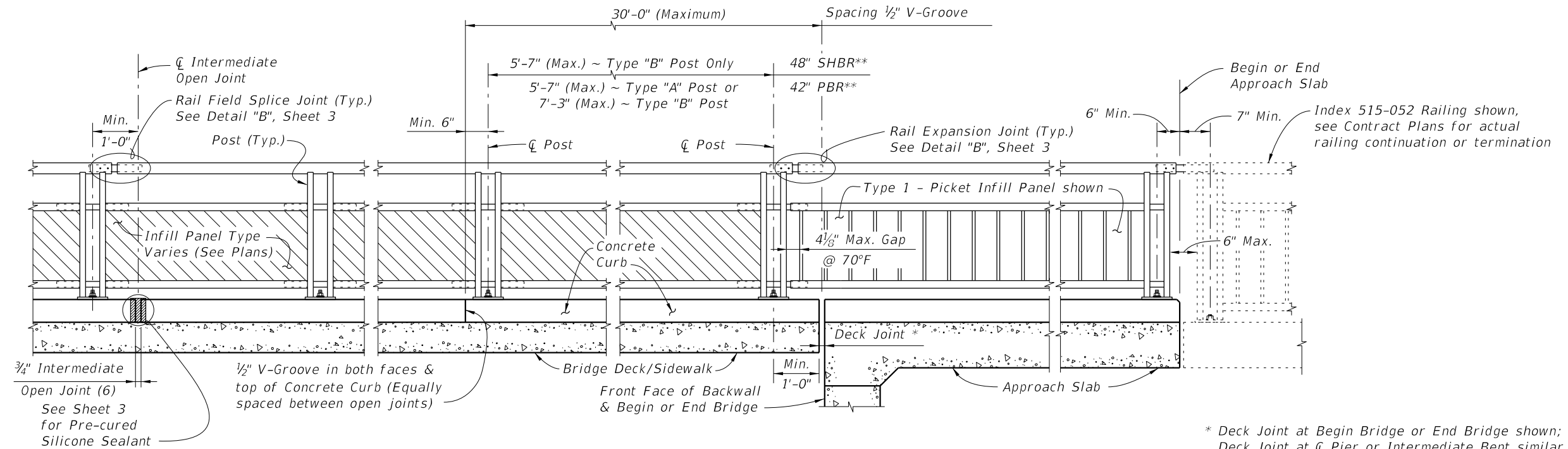

ELEVATION OF INSIDE FACE OF RAILING
 (Scheme 2 shown with Post "A", other Schemes similar, Reinforcing Steel not shown for clarity)

* Deck Joint at Begin Bridge or End Bridge shown;
 Deck Joint at ϕ Pier or Intermediate Bent similar.

** SHBR~Special Height Bicycle Rail
 PBR~Pedestrian/Bicycle Rail

NOTES:

1. Shop Drawings are required.
2. Work this Index with Index 515-052 Bicycle/Pedestrian Railing Details (Steel) and Specification Section 515. Refer to the SPI for Design Criteria and Limits of Use.
3. Materials:
 - A. Steel: Galvanized after fabrication
 - a. Fasteners: Hex Head Bolt ASTM A307, Hex Nuts ASTM A563, Washers ASTM F436
 - b. Support Bracket (Scheme 3) L-shape and Stiffener Plate: ASTM A36
 - c. Bottle-guard (Schemes 1 & 3) L-shape: ASTM A36
 - B. Concrete: Same as bridge deck
 - C. Pre-cured Silicone Sealant: Specification Section 932
 - D. Bearing Pads: Provide $\frac{1}{8}$ " Plain, Fabric Reinforced or Fabric Laminated bearing pads that meet the requirements of Specification Section 932 for Ancillary Structures.
4. See Structures Plans, Superstructure Sheets for bridge information including concrete type, deck expansion joint locations and orientations, and thermal movement.
5. Railings:
 - A. For thermal movement greater than 4" (up to a maximum of 5"), clear opening between adjacent pickets, or panels at Rail Expansion Joints above Deck Joints must be reduced to $3\frac{1}{2}$ ".
 - B. For treatment of railings on skewed bridges see Index 521-427.
6. Curbs:
 - A. Match open curb joints at Deck Expansion Joint locations to the deck joint dimension.
 - B. Construct Concrete Curb (Scheme 2) vertical with the top surface finished level transversely. See Concrete Curb Details Sheet 3.
 - C. Provide $\frac{3}{4}$ " Intermediate open joints in curbs coinciding with the $\frac{3}{4}$ " joints in the traffic railing.
7. Payment: Support bracket (Scheme 3) is incidental to the cost of railing. Curb concrete and reinforcing steel (Scheme 2) are included in the bridge deck quantities.

10/23/2018 11:47:26 AM

LAST REVISION 11/01/17	DESCRIPTION:	 FY 2019-20 STANDARD PLANS	BRIDGE PEDESTRIAN/BICYCLE RAILING (STEEL)	INDEX 515-051	SHEET 1 of 3
------------------------------	--------------	---	--	-------------------------	------------------------

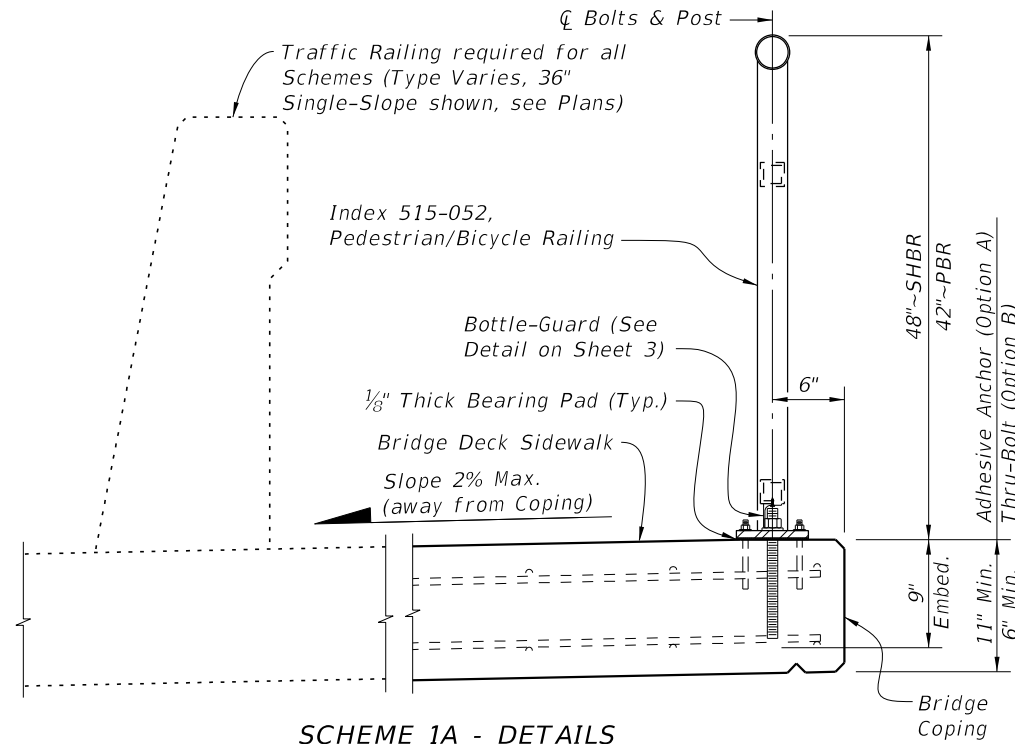

SCHEME 1A - DETAILS
(Adhesive Anchor Option shown)

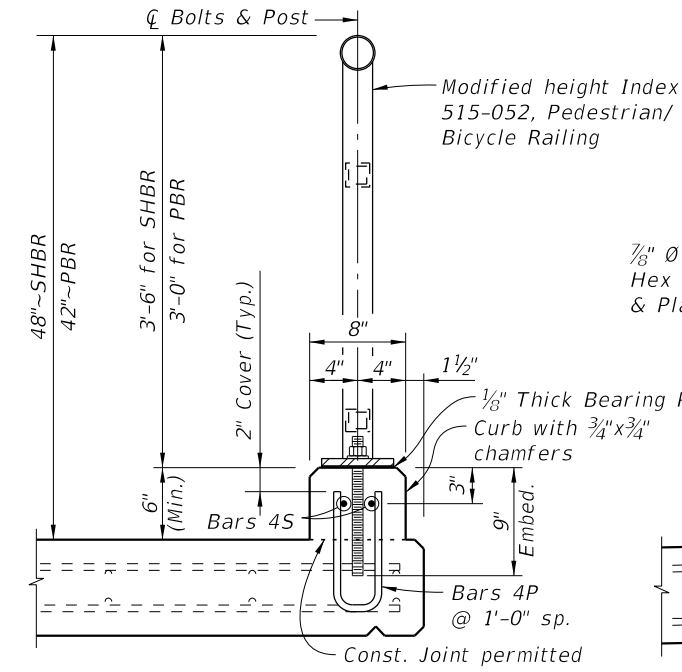

SCHEME 2 - TYPICAL SECTION THROUGH CURB MOUNTED RAILING

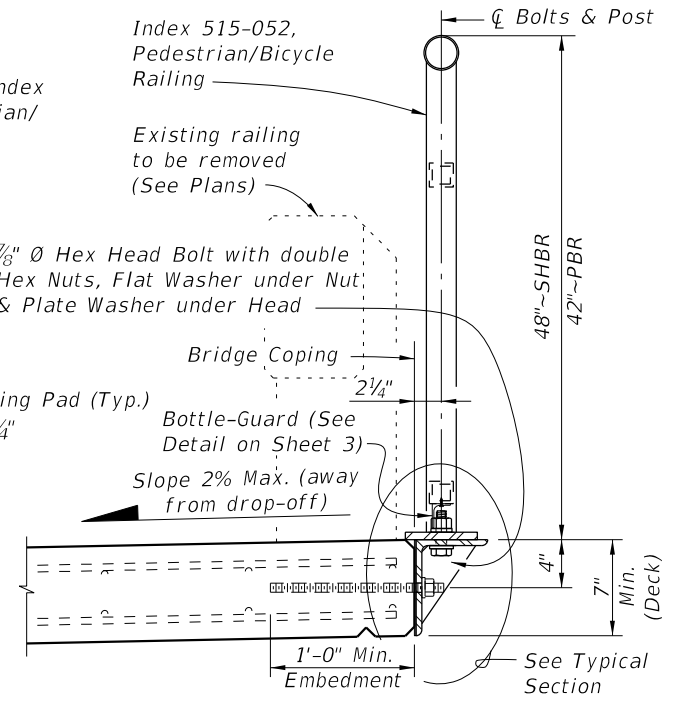

SCHEME 3 - TYPICAL SECTION THROUGH SIDE MOUNTED RAILING (RETROFIT)

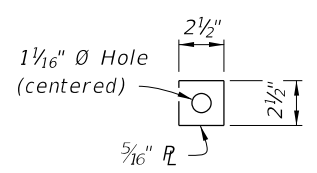

THRU-BOLT PLATE WASHER DETAIL

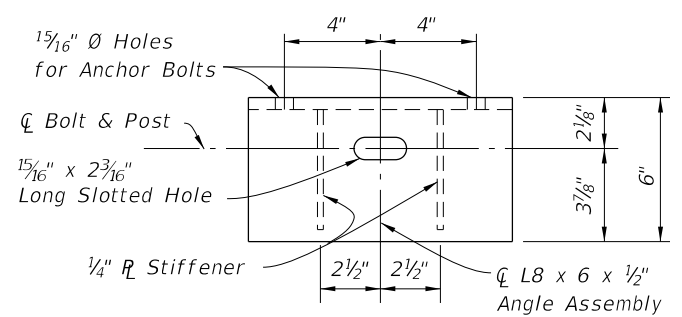

PLAN VIEW

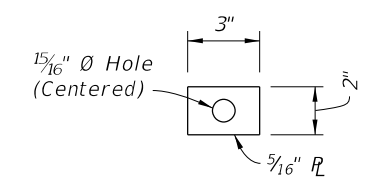
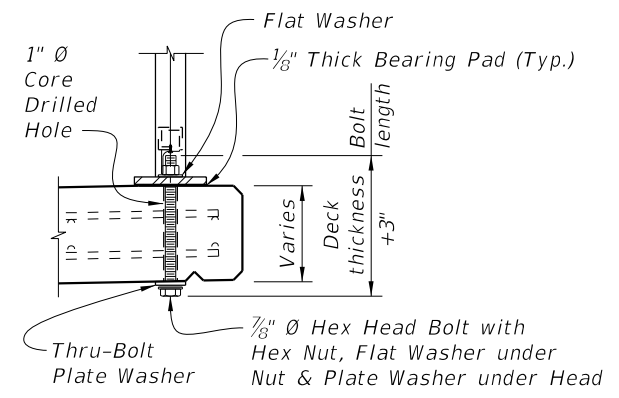
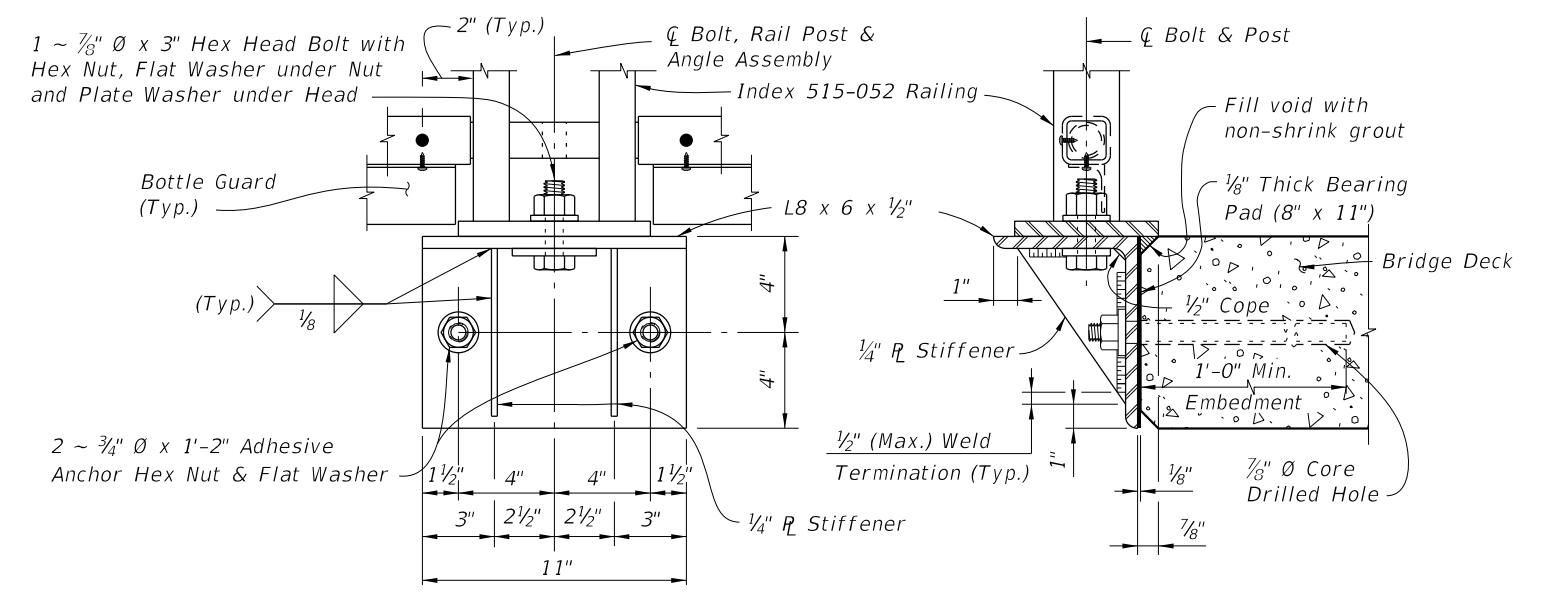

PLATE WASHER DETAIL



SCHEME 1B - DETAILS
(Thru-Bolt Option)



SCHEME 3 - SIDE-MOUNTED SUPPORT BRACKET DETAILS

SCHEME 1 - TYPICAL SECTION THROUGH DECK MOUNTED RAILING

11:47:27 AM 10/23/2018

LAST REVISION 11/01/17	DESCRIPTION:	 FY 2019-20 STANDARD PLANS	BRIDGE PEDESTRIAN/BICYCLE RAILING (STEEL)	INDEX 515-051	SHEET 2 of 3
---------------------------	--------------	--	---	-------------------------	------------------------

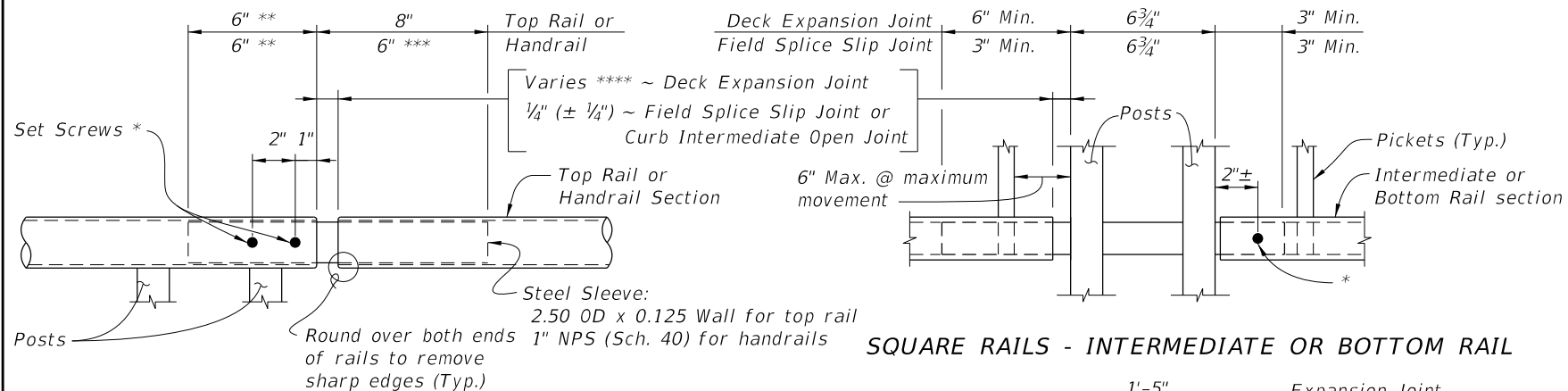

ROUND RAILS - TOP RAIL OR HANDRAIL

- * 1/4" Ø x 3/4" Pan Head Stainless Steel (Type 316 or 18-8 Alloy) Set Screws along outside face of railing. Set screws must be set flush against the rail surface. A 3/4" Ø plug weld may be substituted for the two set screws at expansion joints.
- ** Embedded length may be 4" for plug welded connection.
- *** Increase handrail sleeve embedment to 8" for Expansion Joint openings greater than 2".
- **** Expansion Joint opening shall match the clear opening in the deck joint but not greater than 3".

SQUARE RAILS - INTERMEDIATE OR BOTTOM RAIL

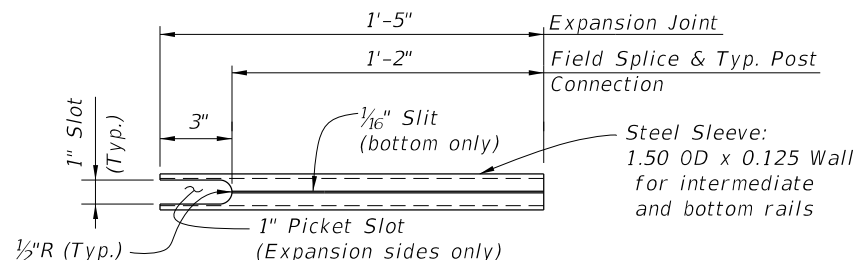

INTERMEDIATE OR BOTTOM RAIL - STEEL SLEEVE DETAIL (Bottom Side Shown)

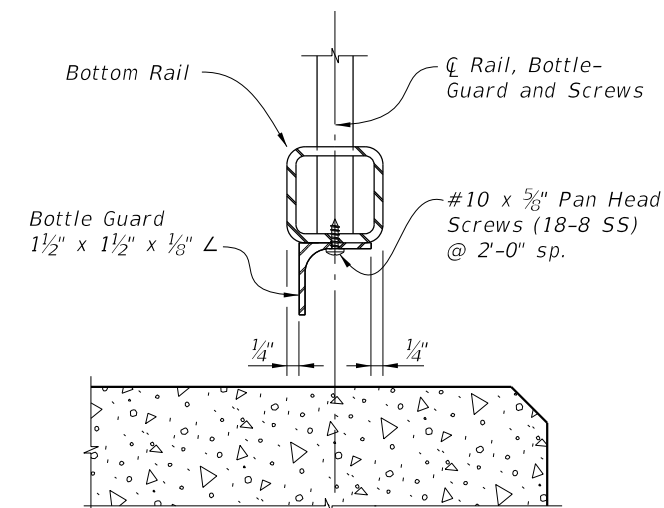

TYPICAL SECTION THROUGH BOTTOM RAIL (Post Not Shown for Clarity)

SCHEME 1 - BOTTLE GUARD DETAIL

DETAIL "B" EXPANSION JOINT (FIELD SPLICE SIMILAR)

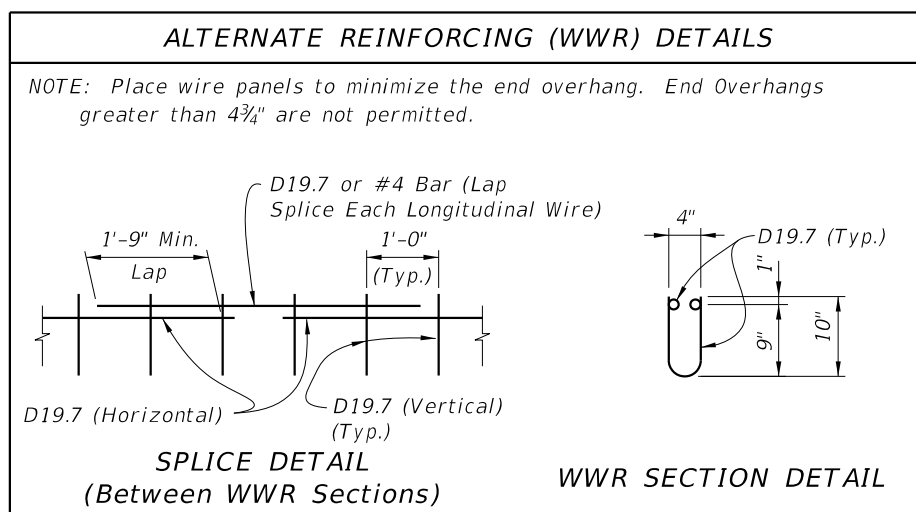

CONVENTIONAL REINFORCING STEEL BENDING DIAGRAMS

BILL OF REINFORCING STEEL

MARK	SIZE	LENGTH
P	4	2'-0"
S	4	As Req'd.

CROSS REFERENCE:
See Sheet 1 for Bridge Railing Notes.

- CURB REINFORCING STEEL NOTES:**
- All bar dimensions in the bending diagrams are out to out.
 - The reinforcement for the curb on a retaining wall shall be the same as detailed for an 8" deck.
 - All reinforcing steel at the open joints shall have a 2" minimum cover.
 - Bars 4S may be continuous or spliced at the construction joints. Bar splices for Bars 4S shall be a minimum of 1'-8".
 - Deformed Welded Wire Reinforcement (WWR) meeting the requirements of Specification Section 931 may be used in lieu of all Bars 4P and 4S.

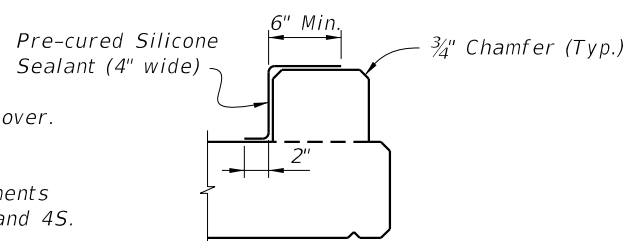

DETAIL "A" - SECTION AT INTERMEDIATE OPEN JOINT

INTERMEDIATE JOINT SEAL NOTE:
At Intermediate Open Joints, seal the lower 6" portion of the open joint with Pre-cured Silicone Sealant. Apply sealant prior to any Class V finish coating and remove all curing compound and loose material from the surface prior to application of bonding agent.

ESTIMATED CONCRETE CURB QUANTITIES (SCHEME 2)

ITEM	UNIT	QUANTITY
Concrete	CY/LF	0.0124
Reinforcing Steel	LB/LF	4.01

SCHEME 2 - CONCRETE CURB DETAILS

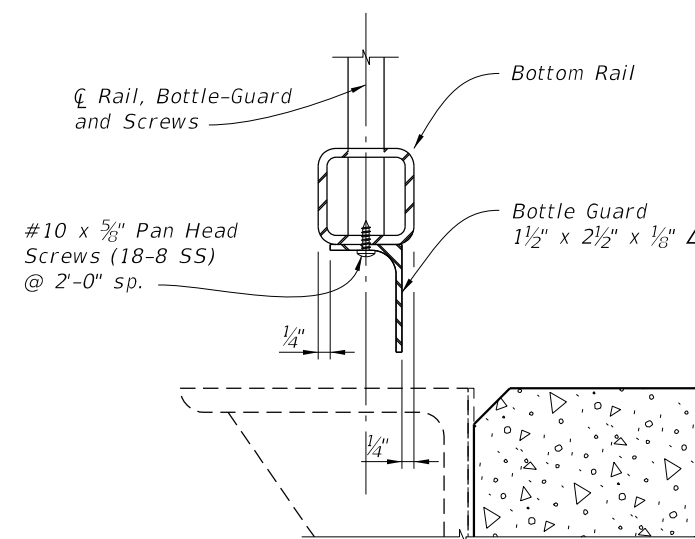

TYPICAL SECTION THROUGH BOTTOM RAIL (Post Not Shown for Clarity)

SCHEME 3 - BOTTLE GUARD DETAIL

10/23/2018 11:47:27 AM