

TYPICAL BRIDGE MOUNTS

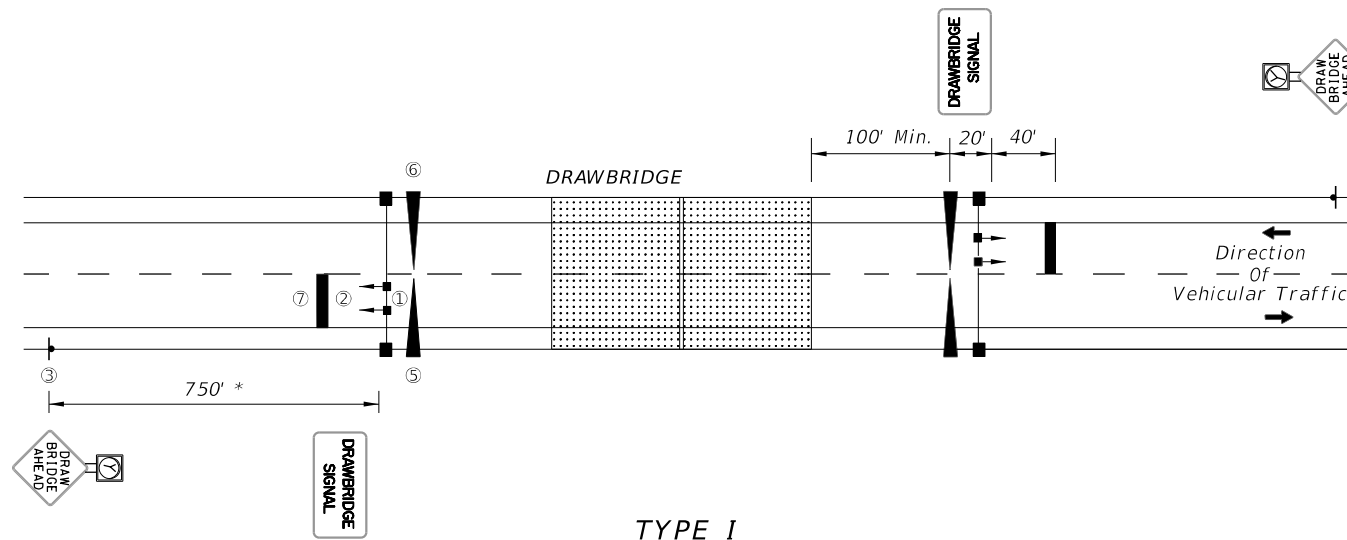

TYPE I

TO BE USED WHERE BRIDGE OPERATORS ARE FULL TIME OR A DAILY BASIS.

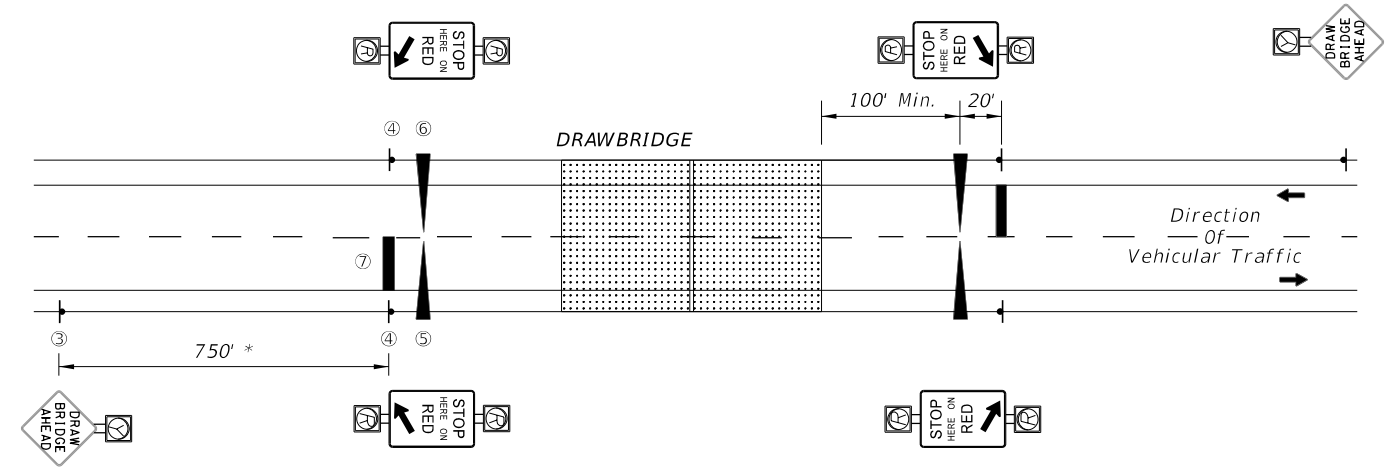

TYPE II

TO BE USED WHERE TYPE I IS NOT APPLICABLE (USUALLY WHEN THE BRIDGE OPERATOR IS "ON CALL").

LEGEND:

- ① TRAFFIC SIGNALS } Mast Arm Mounted (Off Bridge)
- ② DRAWBRIDGE SIGN } Monotube Support Mounted (On Bridge)
- ③ DRAWBRIDGE AHEAD SIGN WITH YELLOW FLASHING BEACON } Ground Mounted
- ④ STOP HERE ON RED SIGN WITH RED FLASHING BEACONS }
- ⑤ ENTRANCE GATE
- ⑥ EXIT GATE
- ⑦ 24" THERMOPLASTIC STOP BAR

NOTES:

1. A bypass switch shall be installed to override each timing interval in case of a malfunction.
2. "STOP HERE ON RED" is omitted in Type I operation and "TRAFFIC SIGNALS" are omitted in Type II operation.
3. The time between beginning of flashing yellow on "Drawbridge Ahead" sign and the clearance of traffic signal to red, or beginning of flashing red should not be less than the travel time of a passenger car, from the sign location to the stop line, traveling at the 85 percentile approach speed.
4. Beginning of operation of drawbridge gates shall not be less than 15 seconds after steady red or 20 seconds after flashing red (Actual time may be determined by the bridge tender.)
5. Time of gate lowering and raising is dependent upon gate type.
6. Time of bridge opening is determined by the bridge tender.
7. Each gate shall be operated by a separate switch.
8. On each approach (Type II), all four red signals shall be on the same two circuit flashers, with the two top signals on one circuit, and the two bottom signals on the alternately flashing circuit.
9. A Drawbridge Ahead sign is required for both types of signal operation, However a flashing beacon shall be added to the sign when physical conditions prevent a driver traveling at the 85% approach speed from having continuous view of at least one signal indication for approximately 10 seconds.
10. Requirements on gate installation are contained in Section 4I of the "Manual on Uniform Traffic Control Devices".
11. "In accordance with Traffic Engineering Manual (Topic Number 750-000-005) Section 2.1, SLIPPERY WHEN WET SIGNS shall be placed in advance of all MOVABLE and NONMOVABLE STEEL DECK BRIDGES."



W8-5
SLIPPERY WHEN WET SIGN
See Note 11

* Field conditions may require adjustment of this standard distance.

SEQUENCE CHART

SIGNALS & SIGNS	SIGNAL SWITCH	OFF	ON	OFF			
	FLASHING BEACON	BLANK	FLASHING YELLOW	BLANK			
	DRAWBRIDGE AHEAD SIGN (See Note 9)	BLANK	FLASHING RED	BLANK			
	STOP HERE ON RED (Type II only)	BLANK	FLASHING RED	BLANK			
	TRAFFIC SIGNALS (Type I only)	GREEN	YELLOW	RED	GREEN		
GATES	ENTRANCE GATES	RAISED					
	EXIT GATES	LOWERED					
TIMING		Variable Time (See Note 3)	5 Sec. Min.	15 Sec. Min.	Variable Time (See Note 5)	Variable Time Bridge Open (See Note 6)	Variable Time (See Note 5)
		Normal Operation		Operation During Bridge Preemption			

9/18/2018 3:00:25 PM

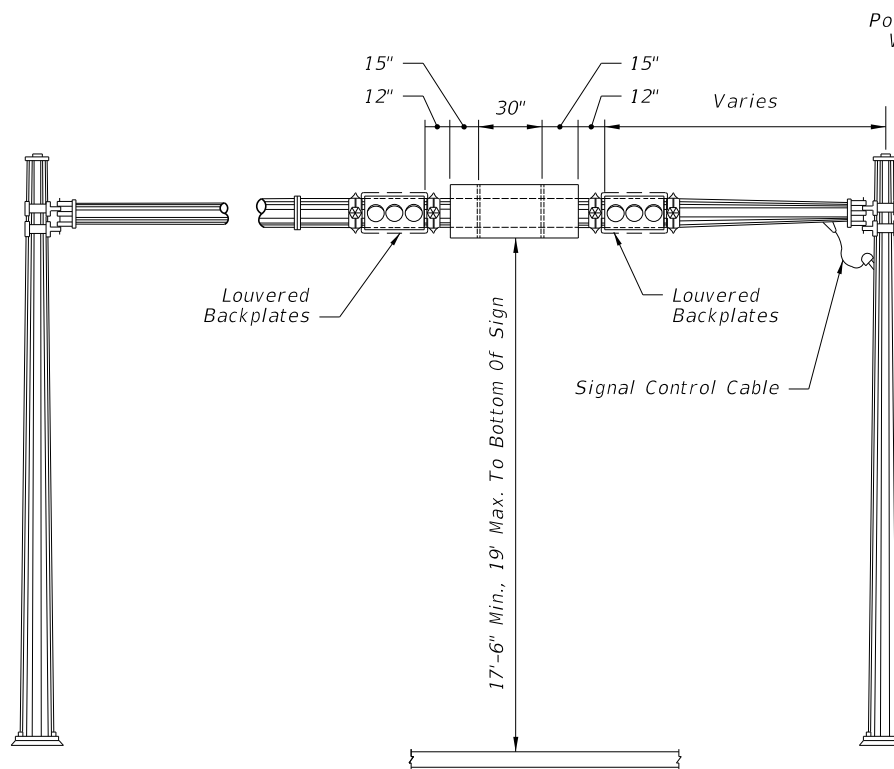

FIGURE - A
MONOTUBE SUPPORT MOUNTING

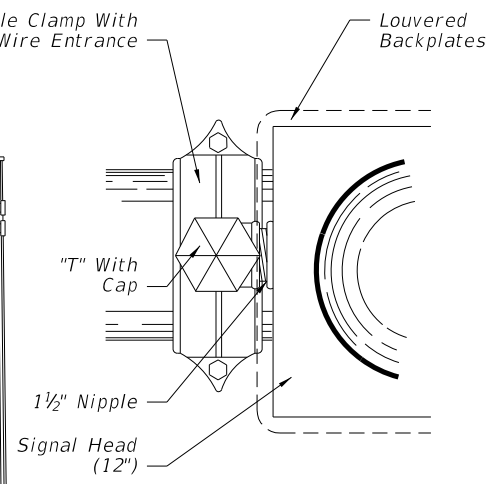

FIGURE - C

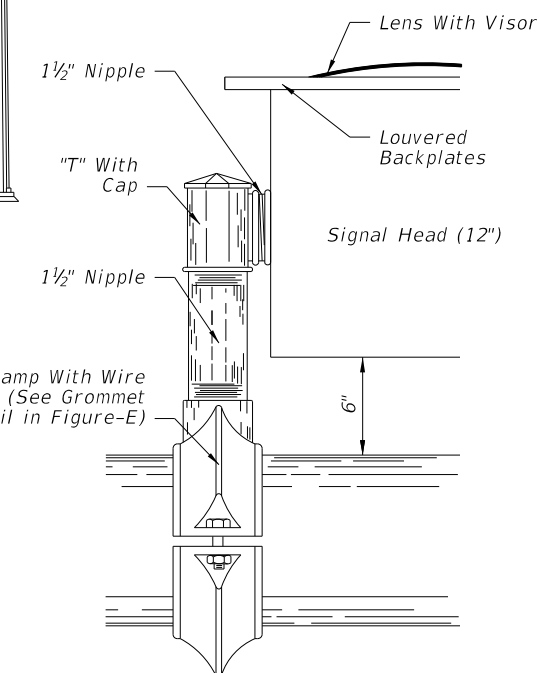

FIGURE - D

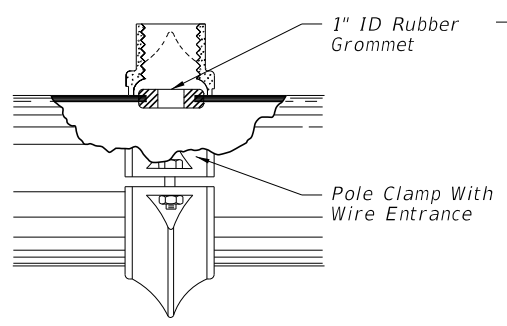

FIGURE - E

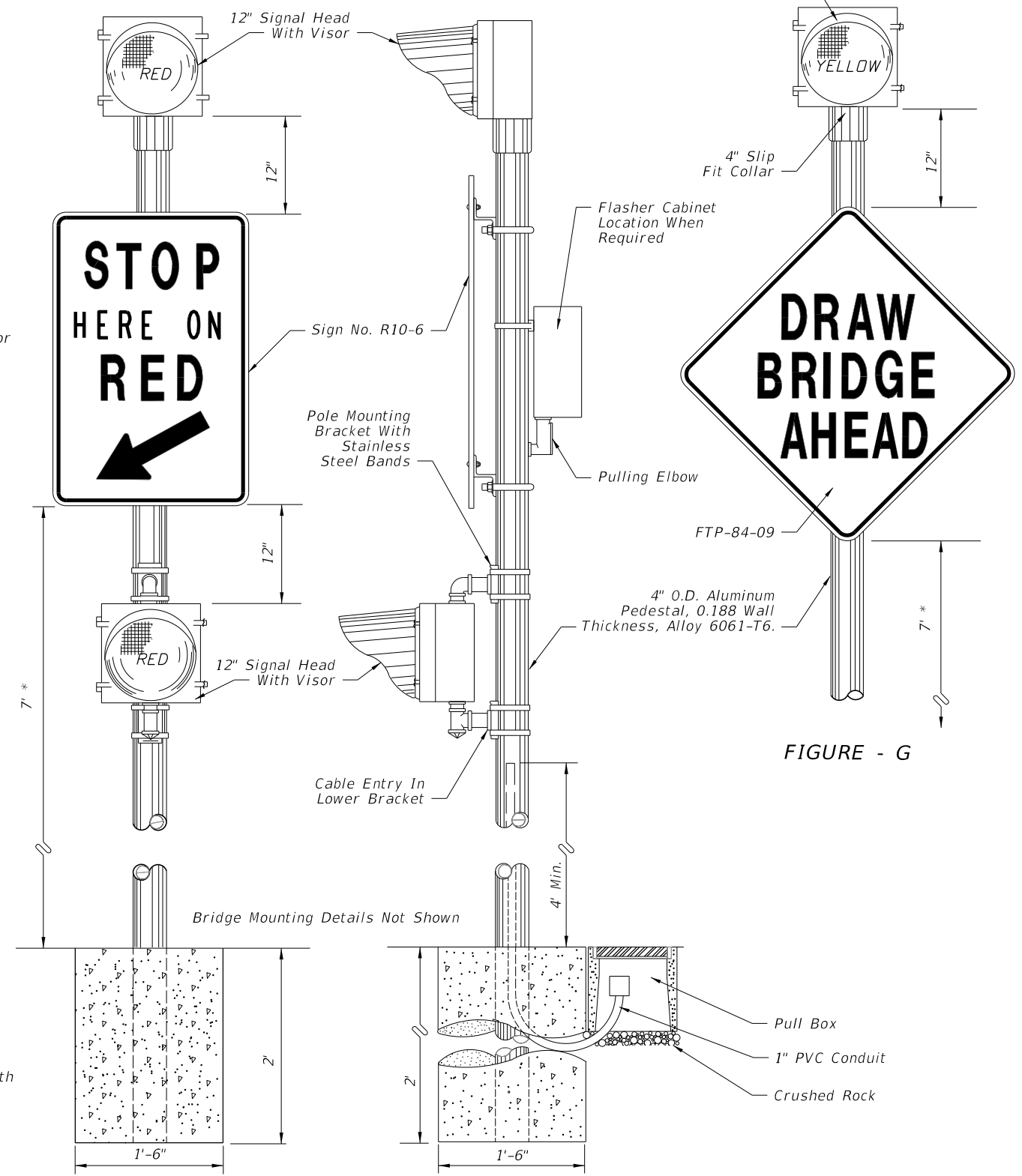

FIGURE - G

FIGURE - F

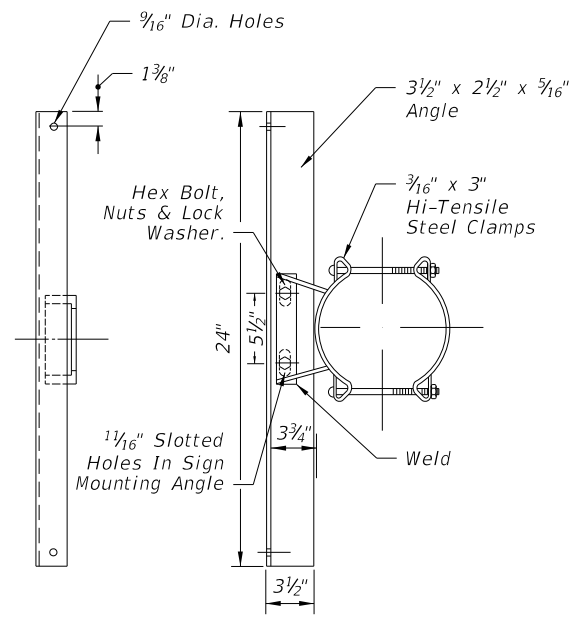

FIGURE - B

SIGN PANEL MOUNTING ASSEMBLY

SIGNAL HEAD MOUNTING ASSEMBLY

* Measured from the bottom of the sign to the near edge of the pavement. Horizontal distance between edge of the pavement and inside edge of sign will vary with condition at job site.

9/18/2018 3:00:27 PM

LAST REVISION 11/01/17	REVISION	DESCRIPTION:		FY 2019-20 STANDARD PLANS	TRAFFIC CONTROL DEVICES FOR MOVABLE SPAN BRIDGE SIGNALS	INDEX 508-T01	SHEET 2 of 3
---------------------------	----------	--------------	--	------------------------------	--	------------------	-----------------

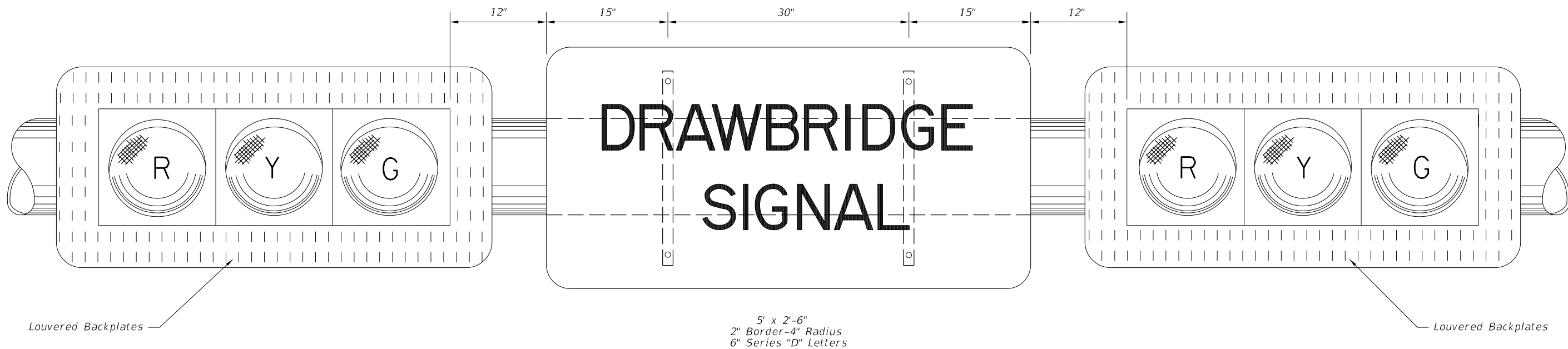

**BLACK OPAQUE LEGEND AND BORDER ON REFLECTORIZED YELLOW BACKGROUND
 TO BE USED WITH TYPE I OPERATION, AS SHOWN ON PREVIOUS SHEET
 MONOTUBE SUPPORT MOUNTING**

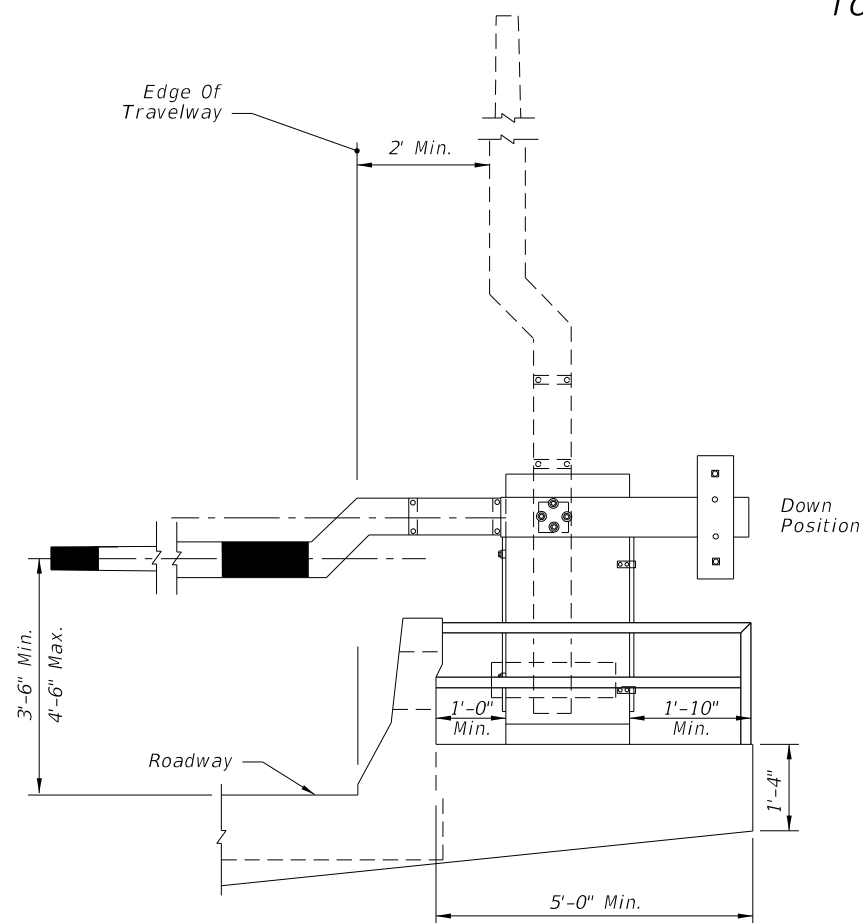

GATE & ARM DETAIL

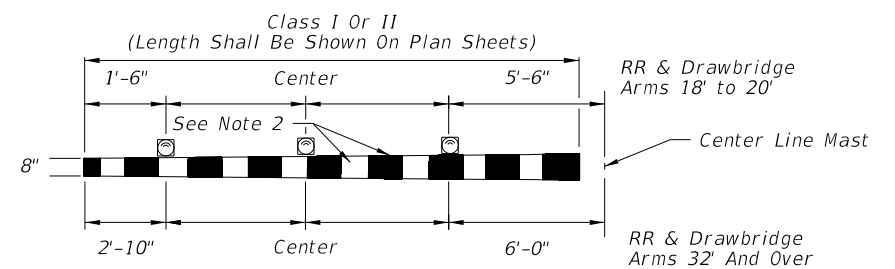
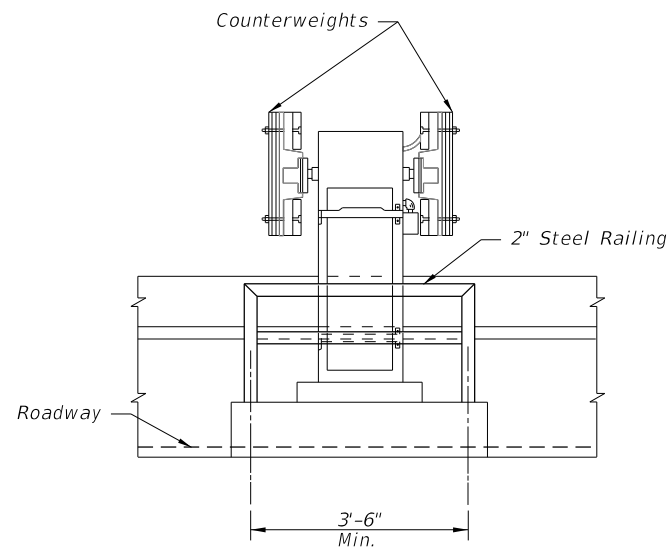

NOTES:

1. 12 volt flashing red lights shall be mounted on gate arm and shall operate in the flashing mode only when gate arm is in the lower position or in the process of being lowered. The number of lights shall vary accordingly to length of the gate arm.
2. Alternating 16" pattern of fully reflectORIZED red and white stripes.

TYPICAL LAMP PLACEMENT

9/18/2018 3:00:28 PM

LAST REVISION 11/01/17	DESCRIPTION:	 FY 2019-20 STANDARD PLANS	TRAFFIC CONTROL DEVICES FOR MOVABLE SPAN BRIDGE SIGNALS	INDEX 508-T01	SHEET 3 of 3
----------------------------------	--------------	--	--	-------------------------	------------------------