

TRAFFIC RAILING NOTES

This Traffic Railing Retrofit has been structurally evaluated to be equivalent or greater in strength to a design which has been successfully crash tested in accordance with NCHRP Report 350 TL-4 criteria.

CONCRETE: Concrete for Transition Blocks and Curbs shall be Class II (Bridge Deck).

REINFORCING STEEL: Reinforcing steel shall be ASTM A615, Grade 60.

THRIE-BEAM GUARDRAIL: Steel Thrie-Beam Elements shall meet the requirements for Class B (10 Gauge) Guardrail of AASHTO M 180, Type II (Zinc coated). The minimum panel length for Thrie-Beam Elements shall be 12'-6". Field drilled holes for Post connections shall be 3/4" by 2 1/2" slotted holes.

GUARDRAIL BOLTS: Guardrail bolts, nuts and washers shall be in accordance with AASHTO M180.

GUARDRAIL POSTS AND BASE PLATES: Posts and Base Plates shall be in accordance with ASTM A36 or ASTM A709 Grade 36.

ANCHOR BOLTS, NUTS AND WASHERS: Adhesive-Bonded Anchors and Anchor Bolts shall be fully threaded rods in accordance with ASTM F1554 Grade 105 or ASTM A193 Grade B7. At the Contractor's option, Anchor Bolts for through bolting may be in accordance with ASTM A449. All Nuts shall be single self-locking hex nuts and in accordance with ASTM A563 or ASTM A194. Flat Washers shall be in accordance with ASTM F436 and Plate Washers (for long slotted holes only) shall be in accordance with ASTM A36 or ASTM A709 Grade 36. After the nuts have been snug tightened, the anchor bolt threads shall be distorted to prevent removal of the nuts. Distorted threads and the exposed trimmed ends of anchors shall be coated with a galvanizing compound in accordance with the Specifications.

COATINGS: All Nuts, Bolts, Anchors, Washers, Guardrail Posts, Anchor Plates and Base Plates shall be hot-dip galvanized in accordance with the Specifications. Guardrail Post Assemblies shall be hot-dip galvanized after fabrication.

ADHESIVE-BONDED ANCHORS AND DOWELS: Adhesive Bonding Material Systems for Anchors and Dowels shall comply with Specification Section 937 and be installed in accordance with Specification Section 416. The field testing proof loads required by Specification Section 416 shall be 15,000 lbs. for 7/8" Ø anchor bolts; 55,000 lbs. for the 1 1/4" anchor bolts with 13" embedment; and 30,500 lbs. for the 1 1/4" Ø anchor bolts with 5" embedment.

BRIDGES ON CURVED ALIGNMENTS: The details presented in these Indexes are shown for bridges on tangent alignments. Details for bridges on horizontally curved alignments are similar.

POST SPACING: Posts shall be located along the length of the bridge at typical 6'-3" or 3'-1 1/2" spaces. Utilize the Modified Post Spacing at Intermediate Deck Joints Details as required to clear deck joints. Establish post spacing along the bridge and Roadway Guardrail Transition beginning with the Key Post. The variable post spacings located near begin and end bridge may be utilized to optimize the typical post spacing. Variable lengths of guardrail overlap are also permitted to optimize the typical post spacing. Symmetry of post spacing is not necessary.

THRIE-BEAM EXPANSION SECTION: Thrie-Beam Expansion Sections shall be installed at locations shown in the Plans. Install nuts for splice bolts finger-tight at 2 1/2" slots in thrie beam expansion sections. Nuts shall fully engage bolts with a minimum of one bolt thread extending beyond the nuts. Distort the first thread on the outside of the nut to prevent loosening. Tighten guardrail bolts in 3 3/4" slots at guardrail post(s) that lie between the slotted expansion splice and bridge deck joint so that the bolt heads are in full contact with thrie-beam elements, but not so tight as to impede movement due to expansion.

BEARING PADS: Provide plain Neoprene pads with a durometer hardness of 60 or 70 and meeting the requirements of Specification Section 932, for ancillary structures.

ELEVATION MARKERS: Elevation Markers need not be replaced when portions of the existing traffic railing carrying existing elevation markers are removed.

BARRIER DELINEATORS: Install Barrier Delineators at the top of the guardrail offset blocks in accordance with Specification Section 705.

PEDESTRIAN SAFETY TREATMENTS: Pedestrian Safety Treatment is required when called for in the Plans. See Index 536-001 for details.

BRIDGE NAME PLATE: If a portion of the existing Traffic Railing is to be removed that carries the bridge name, number and or date, or if the installation of the Traffic Railing (Thrie Beam Retrofit) will obscure the bridge name, number and or date, then replace the information that has been removed or obscured, with 3" tall black lettering on white nonreflective sheeting applied to the top of the adjacent guardrail. The information must be clearly visible from the right side of the approaching travel lane. The sheeting and adhesive backing shall comply with Specification Section 994 and may comprise of individual decals of letters and numbers.

PAYMENT: Payment will be made under Metal Traffic Railing (Thrie-Beam Retrofit) which shall include all materials and labor required to fabricate and install the barrier and lapped guardrail where necessary to maintain post spacing. Transition Blocks and Curbs, Bridge Name Plate and Barrier Delineators and installation of Elevation Markers, where required, will not be paid for directly but shall be considered as incidental work.

10/23/2018 12:51:17 PM

LAST REVISION 11/01/17	REVISION	DESCRIPTION:	 FY 2019-20 STANDARD PLANS	TRAFFIC RAILING - (THRIE-BEAM RETROFIT) TYPICAL DETAILS & NOTES	INDEX 460-470	SHEET 1 of 3
------------------------------	----------	--------------	---	--	-------------------------	------------------------

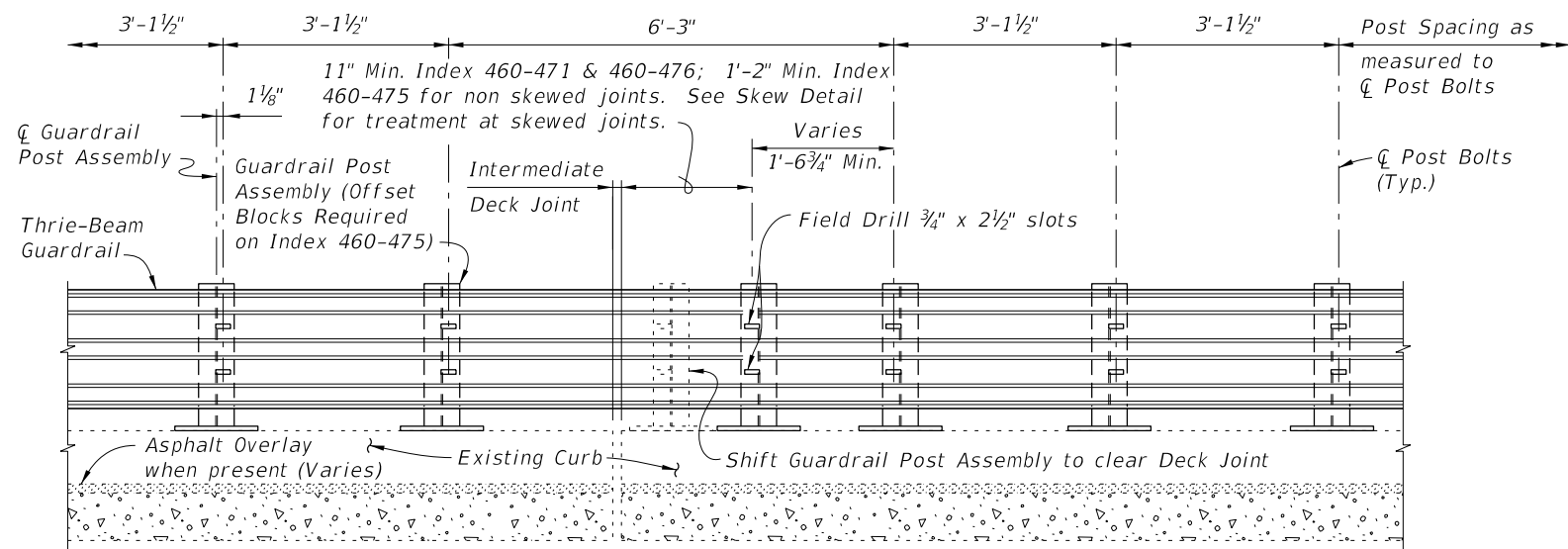

PARTIAL ELEVATION OF INSIDE FACE OF RAILING
 MODIFIED POST SPACING AT INTERMEDIATE DECK JOINTS DETAIL
 FOR INDEX 460-471, 460-475 & 460-476

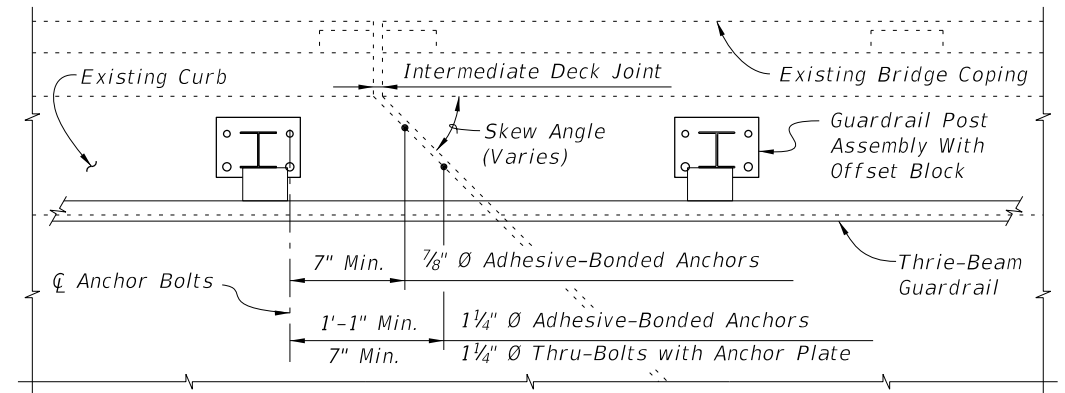

PARTIAL PLAN
 INTERMEDIATE JOINT SKEW DETAIL

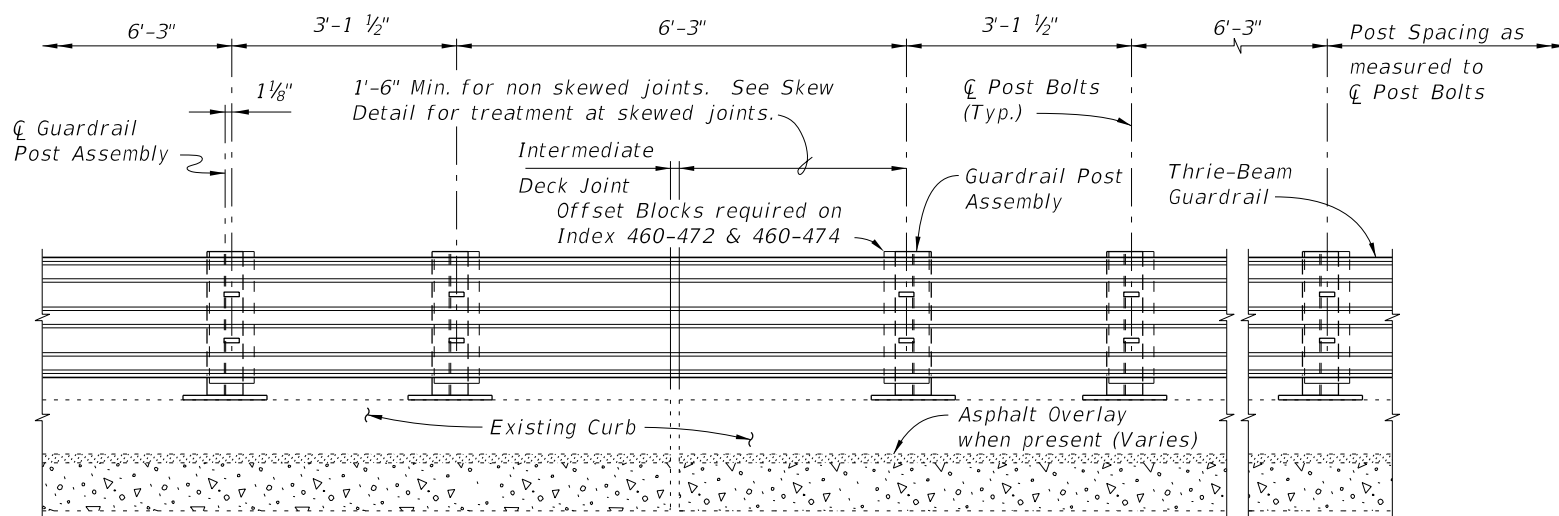

PARTIAL ELEVATION OF INSIDE FACE OF RAILING
 MODIFIED POST SPACING AT INTERMEDIATE DECK JOINTS DETAIL
 FOR INDEX 460-472, 460-473 & 460-474

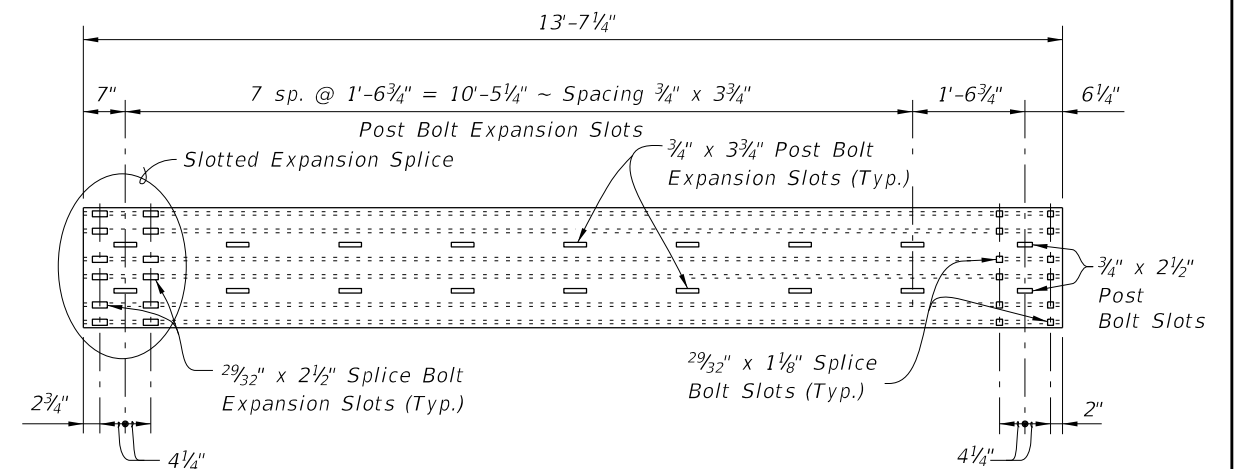

THRIE-BEAM EXPANSION SECTION

10/23/2018 12:51:18 PM

LAST REVISION	DESCRIPTION:
01/01/08	

 FY 2019-20
 STANDARD PLANS

TRAFFIC RAILING - (THRIE-BEAM RETROFIT)
 TYPICAL DETAILS & NOTES

INDEX	SHEET
460-470	2 of 3

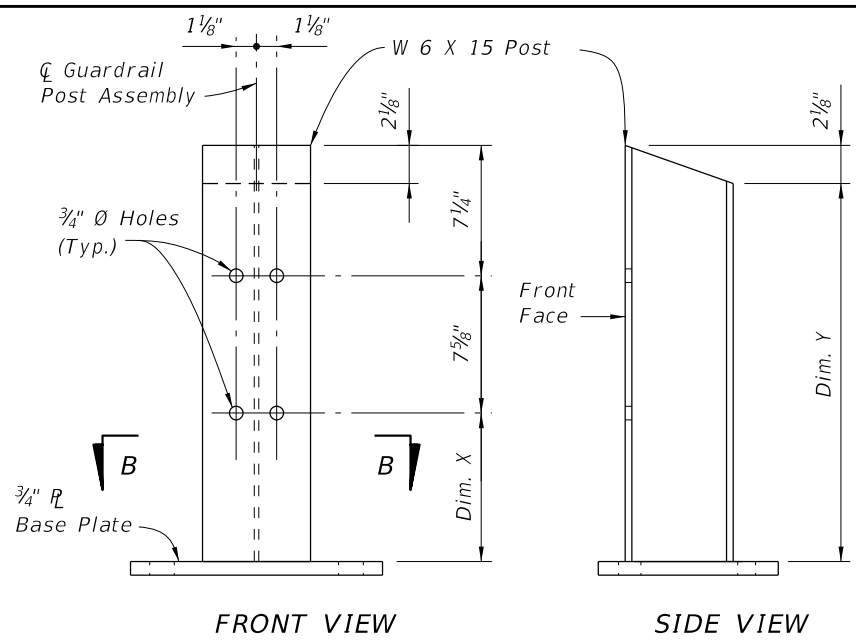

FRONT VIEW **SIDE VIEW**

POST DIMENSION TABLE			
POST	CURB HEIGHT (DIM. A)	DIM. X	DIM. Y
Post "A"	5" to 7"	11 1/4"	2'-0"
Post "B"	> 7" to 10"	9 1/4"	1'-10"
Post "C"	> 10" to 1'-0"	7 1/4"	1'-8"

Note: Dim. A is equal to the exposed curb height. For location of Dim. A see Index 460-471 thru 460-476, Sheet 1.

GUARDRAIL POST ASSEMBLY DETAIL

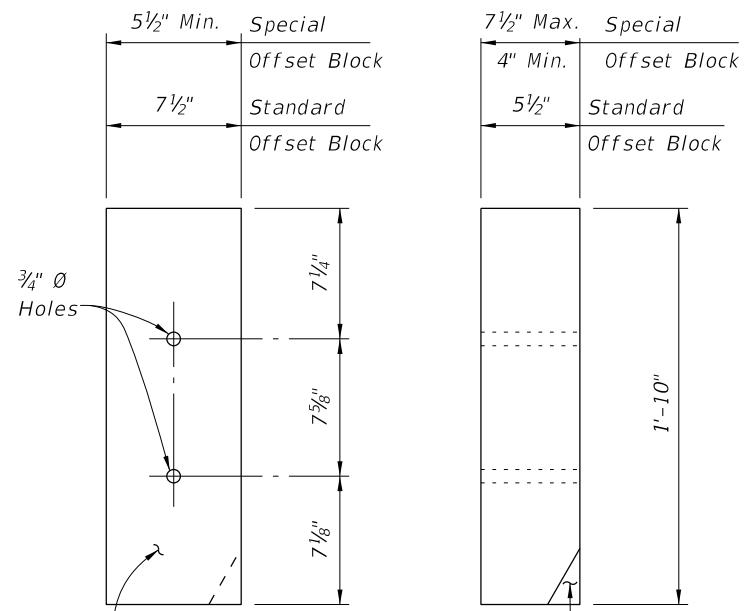

8" x 6" x 1'-10" (Nominal) Timber Offset Block (7 1/2" x 5 1/2" x 1'-10" Dressed Dimensions)
 Pare corner of offset block as required to clear anchor bolt

FRONT VIEW **SIDE VIEW**

OFFSET BLOCK DETAIL

- OFFSET BLOCK NOTES:**
1. Offset blocks shall be timber or Approved Alternate. Uniformity of block size and alignment of guardrail shall be maintained along length of retrofit.
 2. Post bolt holes in offset blocks to be centered ($\pm 1/4"$).
 3. Timber offset blocks shall be dressed on all four sides (S4S).
 4. Block assemblies for Special Offset Blocks can be made up of 2 or 3 Special or Standard Offset Blocks, field dressed as required.

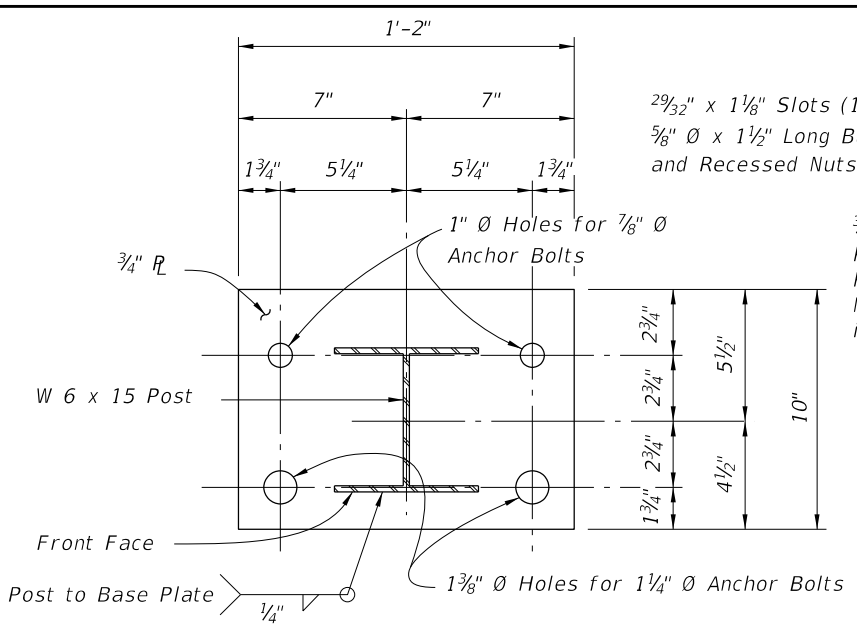

SECTION B-B

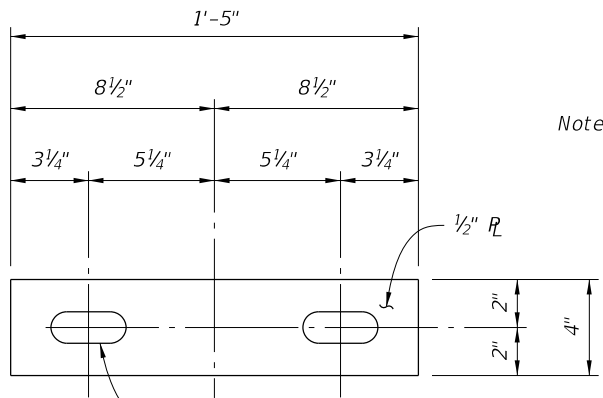

ANCHOR PLATE DETAIL

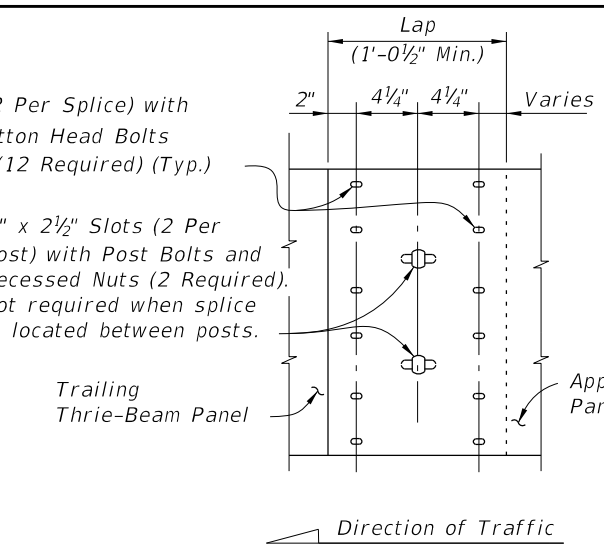

THRIE-BEAM GUARDRAIL SPLICE

Note: All Thrie Beam Panels shall be lapped in the direction of adjacent traffic. At the Contractor's option, laps may be extended. Field drill holes in Trailing Thrie Beam Guardrail Panel as required.

Note: The Anchor Plate and Plate Washer are applicable only to 1 1/4 inch diameter anchor bolts that are to be thru-bolted for Index 460-471 & 460-476.

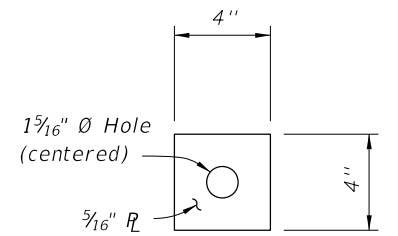
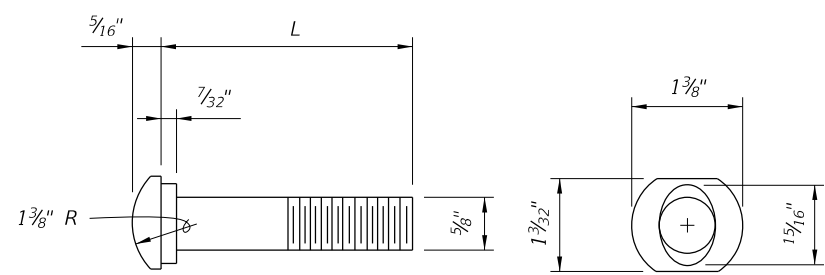
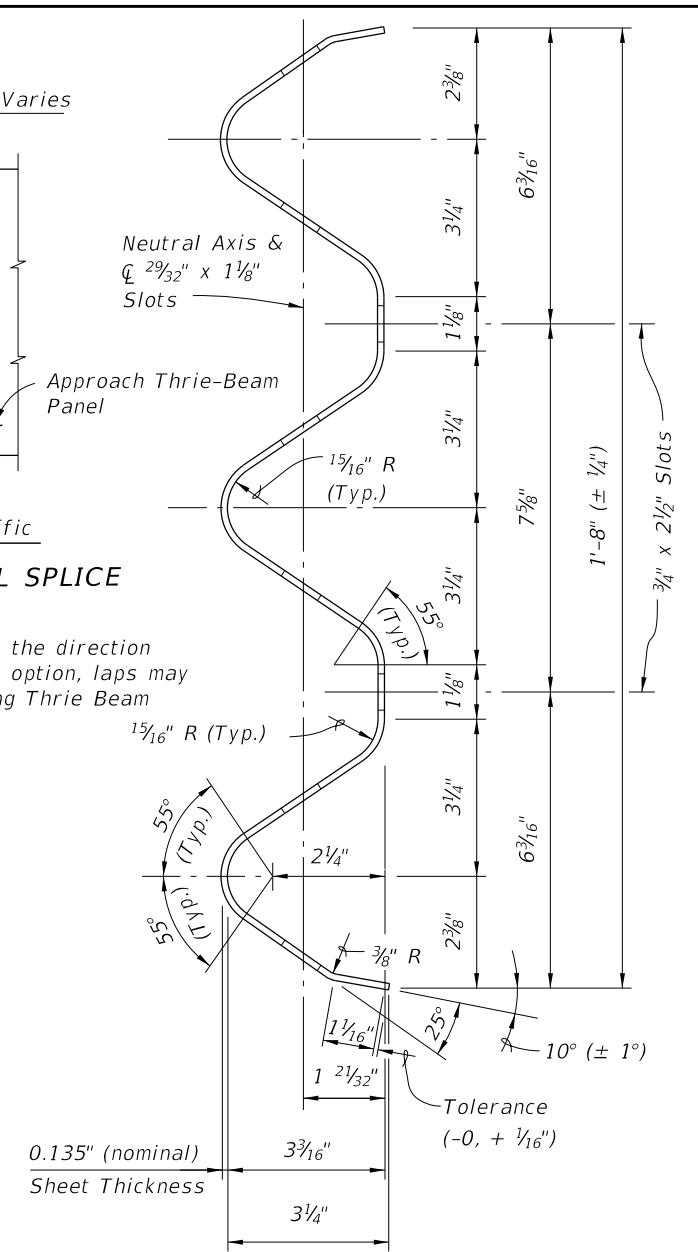

PLATE WASHER DETAIL



5/8" OVAL SHOULDER BUTTON HEAD BOLT

L	THREAD LENGTH	APPLICATION
1 1/2"	Full Length	Rail Splice Bolt, Post Bolt for Index 460-471, 460-473 & 460-476
Varies (8" Min.)	4" Min.	Post Bolt for Index 460-472, 460-473, 460-474, 460-475 & 460-476



TYPICAL SECTION THRU THRIE-BEAM GUARDRAIL (EXPANSION SECTION SIMILAR)

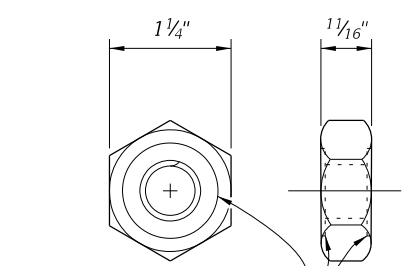

5/8" MODIFIED HEAVY HEX NUT (RECESSED NUT)

10/23/2018 12:51:18 PM