

NOTES:

- For Sections D-D, & E-E, see Index 455-112, 455-114, 455-118, 455-124 or 455-130 for applicable concrete pile size and Pile Splice Reinforcement Details.
- Prestressing strands, spiral ties and/or reinforcement are not shown for clarity.
- In cases where pile splices are desired due to length limitations in shipping and/or handling, the "Drivable Preplanned Prestressed Precast Splice Detail" shall be used.
- When preformed dowel holes are utilized, the 1" spiral tie pitch shall be continued to 4'-0" below the head of the pile, See Index 455-118, 455-124. Preformed holes shall utilize either removable preforming material or stay-in-place corrugated galvanized steel ducts. Stay-in-place ducts shall be fabricated from galvanized sheet steel meeting the requirements of ASTM A653, Coating Designation G90, 26 gauge. Ducts shall be 1½" diameter for CFRP Bars, and 2" diameter for SS Bars with a minimum corrugation (rib) height of 0.12 in. Ducts shall be fabricated with either welded or interlocked seams. Galvanizing of welded seams will not be required.
- For tension piles where top of Prestressed Pile is less than 3 feet below Pile Cut-off Elevation, extend No. 6 CFRP Bars or No. 10 SS into cap beyond Pile Cut-off Elevation to achieve development as approved by the Engineer.

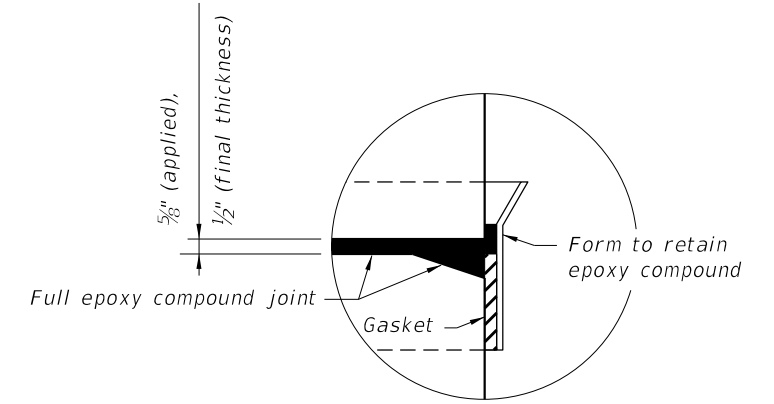

DETAIL A

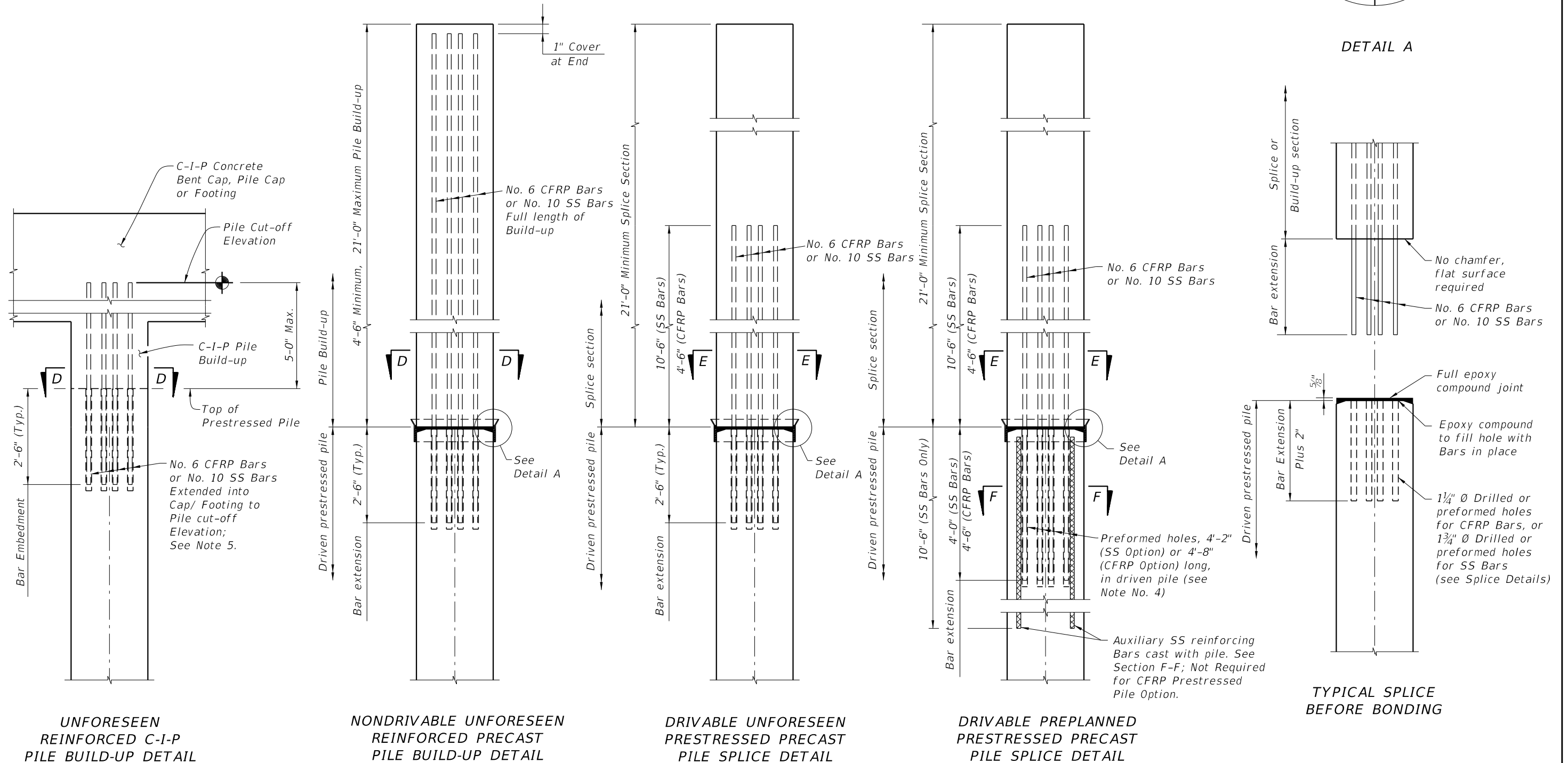

UNFORESEEN REINFORCED C-I-P PILE BUILD-UP DETAIL

NONDRIVABLE UNFORESEEN REINFORCED PRECAST PILE BUILD-UP DETAIL

DRIVABLE UNFORESEEN PRESTRESSED PRECAST PILE SPLICE DETAIL

DRIVABLE PREPLANNED PRESTRESSED PRECAST PILE SPLICE DETAIL

TYPICAL SPLICE BEFORE BONDING

10/23/2018 12:41:55 PM

LAST REVISION 01/01/16	REVISION	DESCRIPTION:		FY 2019-20 STANDARD PLANS	SQUARE CFRP & SS PRESTRESSED CONCRETE PILE SPLICES	INDEX 455-102	SHEET 1 of 1
---------------------------	----------	--------------	--	------------------------------	---	------------------	-----------------