

* These dimensions are measured perpendicular to the end of beam

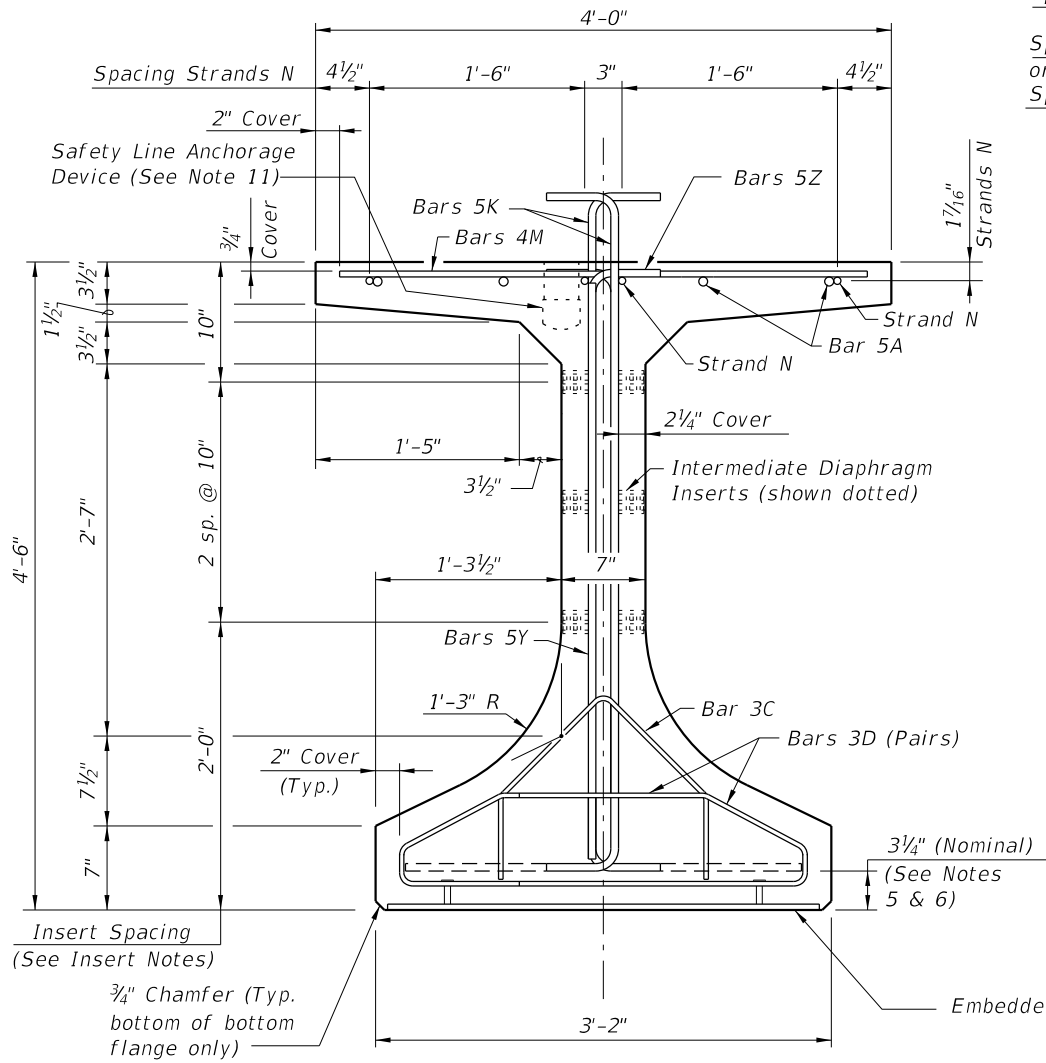

END VIEW

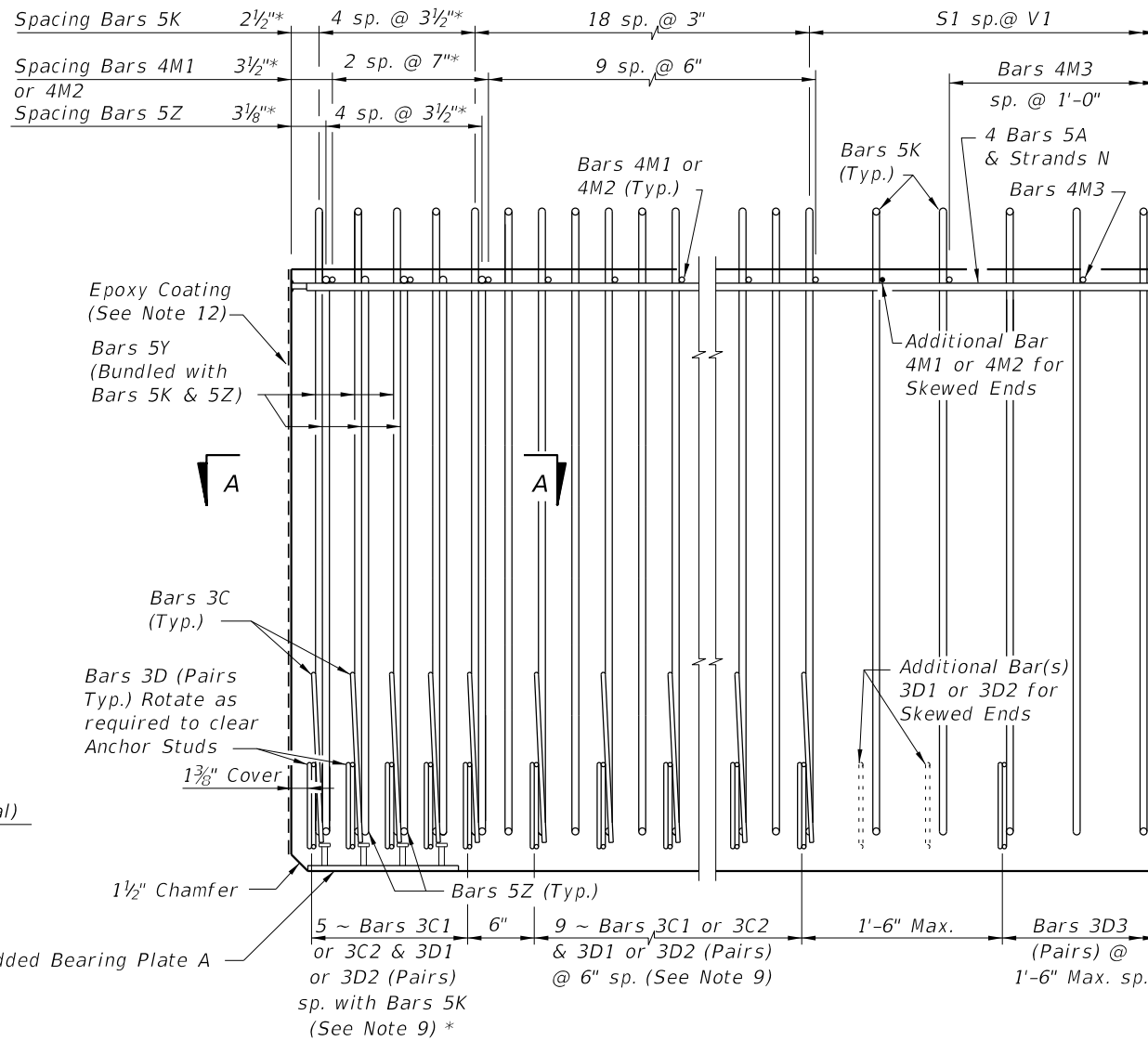

ELEVATION AT END OF BEAM
(Flanges Not Shown For Clarity)
(End 1 Shown, End 2 Similar)

CONVENTIONAL REINFORCING BAR BENDING DETAILS

BILL OF REINFORCING STEEL				
MARK	NOTE NUMBERS	SIZE	NUMBER REQUIRED	LENGTH (NOTE 2)
A	—	5	8	22'-0"
C1	7, 8 & 9	3	14 (End 1)	Varies
C2	7, 8 & 9	3	14 (End 2)	Varies
D1	7, 8, 9 & 10	3	28 (End 1)	Varies
D2	7, 8, 9 & 10	3	28 (End 2)	Varies
D3	9 & 10	3	See Table	4'-3"
K	5, 6, 8, 9 & 10	5	See Table	5'-8"
M1	7 & 9	4	12 (End 1)	Varies
M2	7 & 9	4	12 (End 2)	Varies
M3	9	4	See Table	3'-8"
N	4 & 12	3/8" Ø Strand	4	Dim. L
Y	8 & 9	5	12	4'-0"
Z	5, 6, 8, 9 & 10	5	10	5'-2"

BENDING DIAGRAMS (See Note 2)

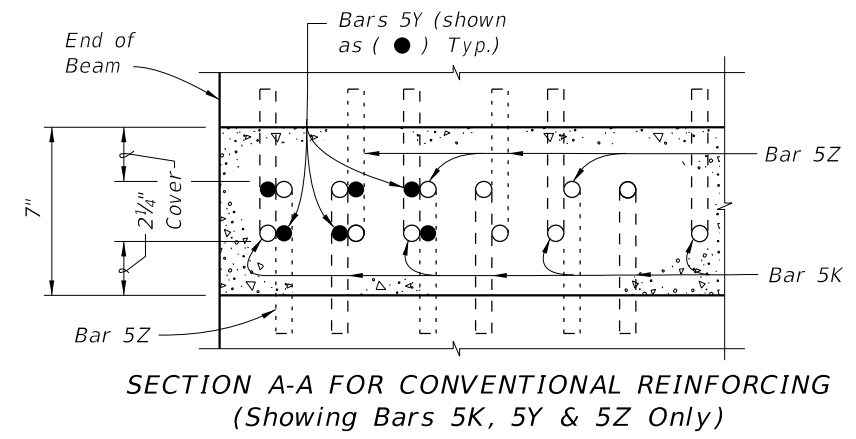

SECTION A-A FOR CONVENTIONAL REINFORCING
(Showing Bars 5K, 5Y & 5Z Only)

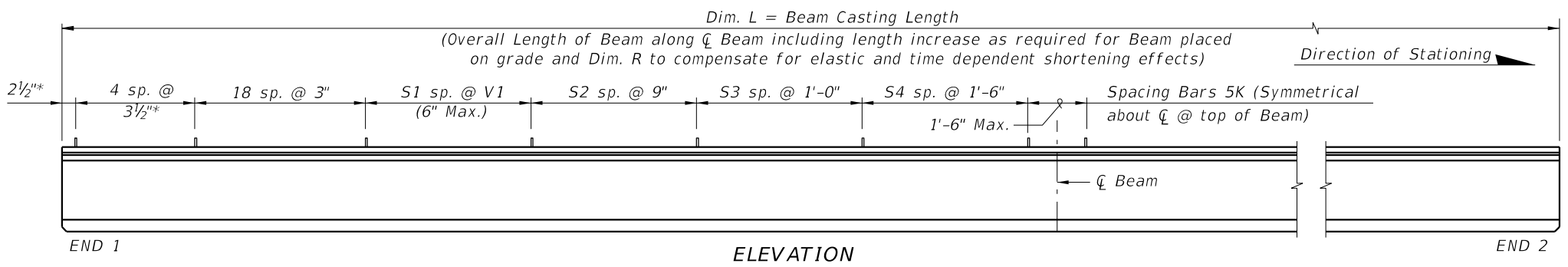

ELEVATION

NOTES:
 A. Work this Index with Index 450-010 - Typical Florida-I Beam Details and Notes and the Florida-I Beam - Table of Beam Variables in Structures Plans.
 B. For referenced notes, see Index 450-010.
 C. For Dimensions A, B, C, D, L, R & V1 and number of spaces S1 thru S4, see Florida-I Beam - Table of Beam Variables in Structures Plans.

10/23/2018 12:24:26 PM

LAST REVISION 11/01/18	DESCRIPTION:
---------------------------	--------------

ALTERNATE REINFORCING STEEL (WWR) DETAILS

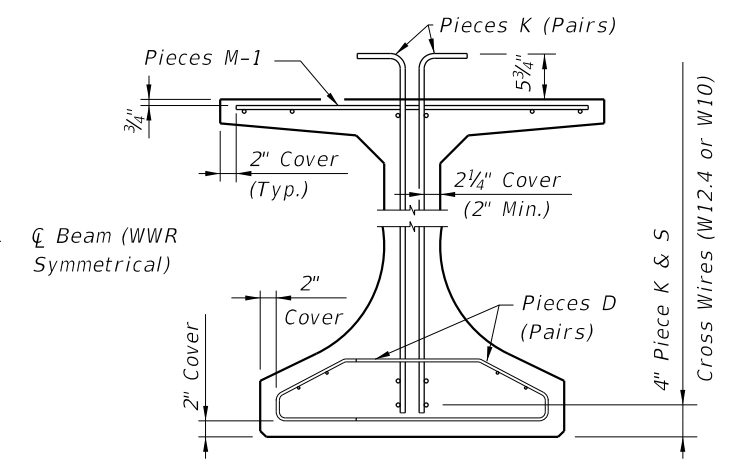
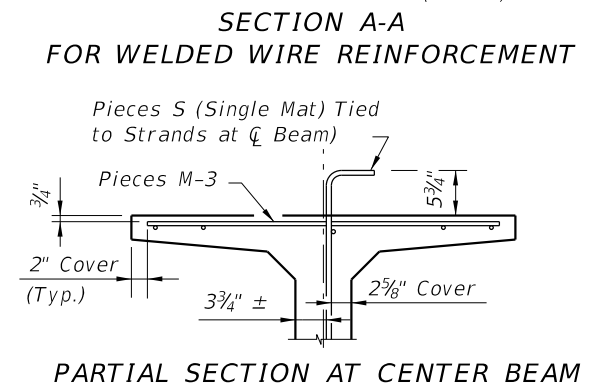
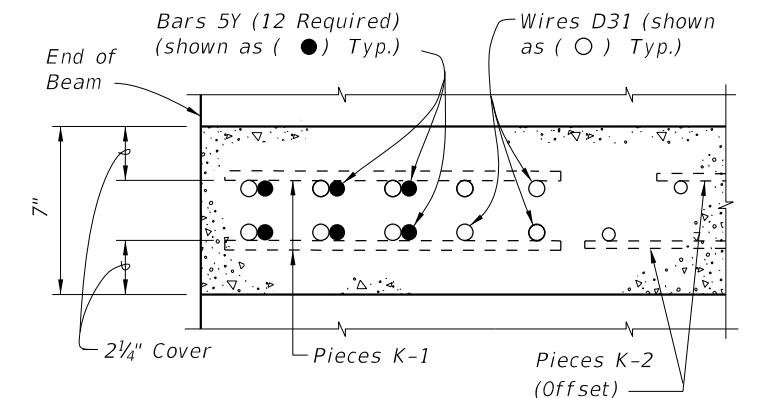
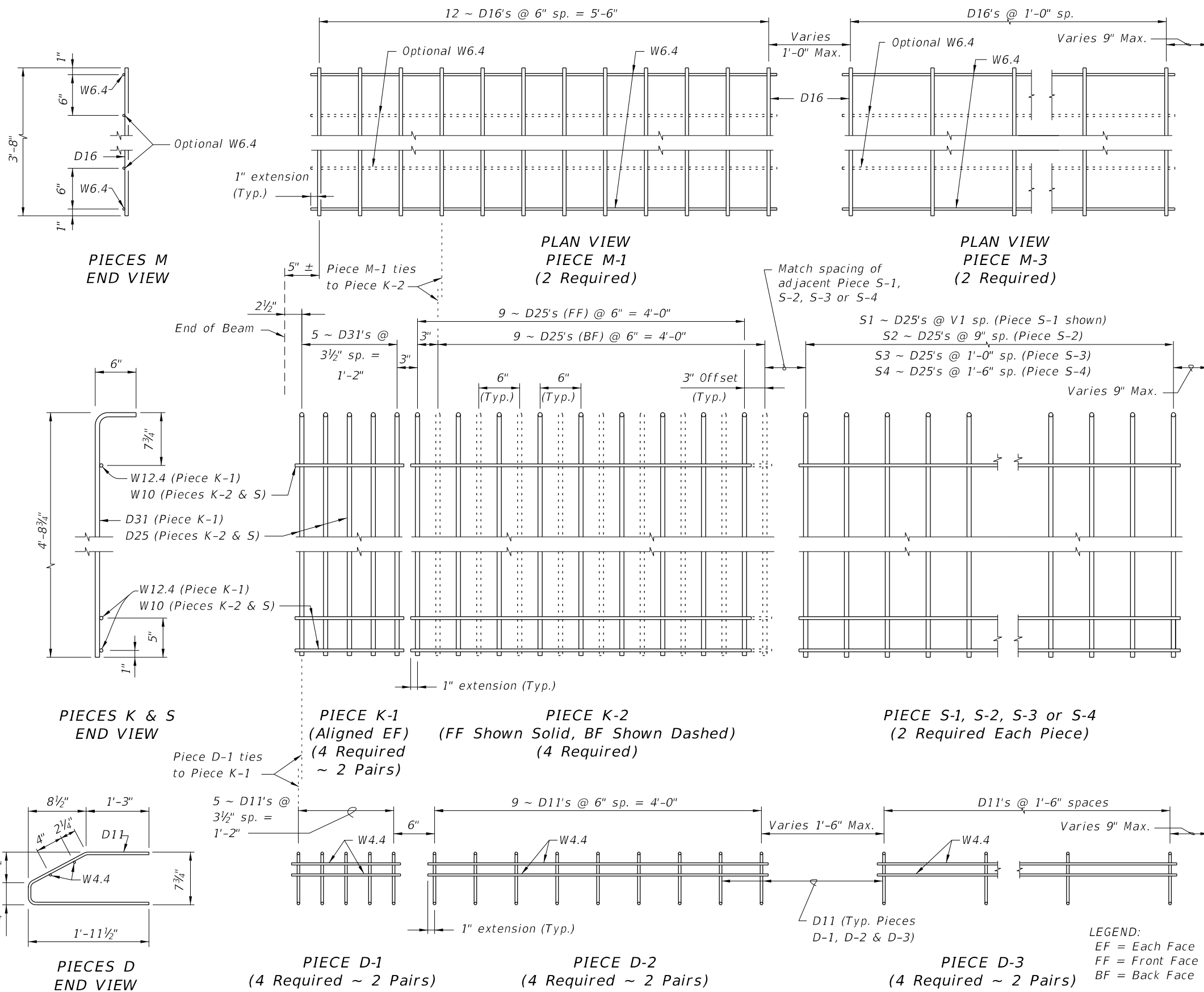

- NOTES:**
- See Sheet 1 for placement details & Table of Beam Variables in Structures Plans for variables S1, S2, S3, S4 & V1.
 - Place Conventional Reinforcing Bars 5A & 3C as shown on Sheet 1. Place additional Bars 5Y as shown in Section A-A for WWR. Bars 5Z will not be used with the WWR Option.
 - Pieces may be fabricated in multiple length sections.
 - For beams with skewed end conditions, Pieces D-1, D-2 & M-1 shall not be used; Conventional Reinforcing Bars D1, D2, C1, C2, M1 & M2 shall be used. See Index 450-010 Skewed Beam End Details and Note 9 for placement details. Shift Pieces K & Bars 5Y to accommodate skewed end conditions and align with Bars C and D.

LEGEND:
 EF = Each Face
 FF = Front Face
 BF = Back Face

10/23/2018 12:24:27 PM

LAST REVISION 11/01/16	DESCRIPTION:	 FY 2019-20 STANDARD PLANS	FLORIDA-I 54 BEAM - STANDARD DETAILS	INDEX 450-054	SHEET 2 of 2
---------------------------	--------------	----------------------------------	--------------------------------------	------------------	-----------------