

NOTE: Alt. B Structure Bottom Only. See Index 425-010 for structure bottom details and hole reinforcement.
(For Pipes 30" Dia. And Larger)
INLET WITH STRUCTURE BOTTOM

RECOMMENDED MAXIMUM PIPE SIZES

Inlet Inside Width	Pipe Size
2'-11" Or 3'-3"	24"
4'-0" Or 3'-10"	30"

Note: Recommended sizes are for concrete pipe. Sizes for other types of pipe must be verified for fit in accordance with Index 425-001. For larger pipe see bottom detail above and Index 425-010.

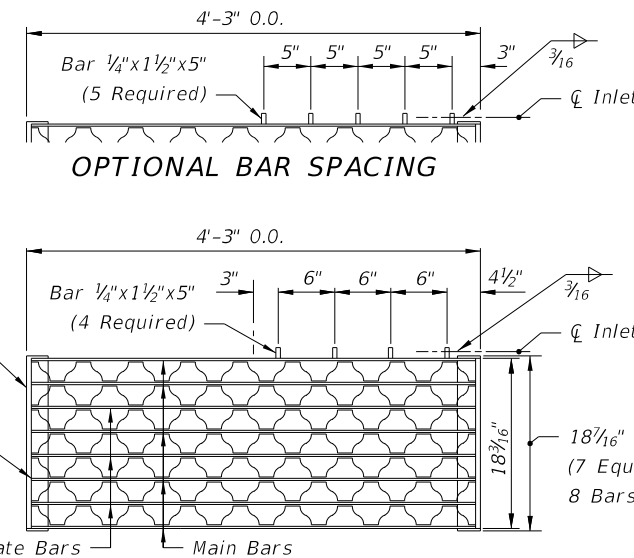

TWO REQUIRED PER INLET

5" Steel Grate: Main Bars 5"x1/4"
Intermediate Bars 1 1/2"x1/4"
Reticuline Bars 1 1/4"x3/16"

GENERAL NOTES

- This inlet is suitable for village swales, ditches, or other areas subject to heavy wheel loads, minimum debris. This inlet may be placed in areas subject to occasional pedestrian traffic such as landscaped areas and pavement areas where pedestrians can walk around the inlet. This inlet is not for use in a bicycle way.
- When alternate "G" grate is specified in plans, the grate is to be hot dip galvanized after fabrication.
- All reinforcing is Grade 60 bars with 2" min. cover unless otherwise noted. See Index 425-001 for equivalent area of welded wire fabric. Cut or bend bars out of way of pipe to clear pipe 1 1/2".
- All exposed edges and corners shall be 3/4" chamfer or tooled to 1/4" radius.
- All dimensions are for both precast and cast-in-place inlets unless otherwise noted.
- For supplementary details see Index 425-001.
- Inlet to be paid for under the contract unit price for Inlets (Gutter Type V), EA

HORIZONTAL WALL REINFORCING SCHEDULE (TABLE 1)

WALL DEPTH	SCHEDULE	AREA (in. ² /ft.)	MAX. SPACING	
			BARS	WWF
0' - 5'	A12	0.20	12"	8"
5' - 9'	A6	0.20	6"	5"
9' - 12'	A4	0.20	4"	3"
9' - 15'	B5.5	0.24	5 1/2"	5"

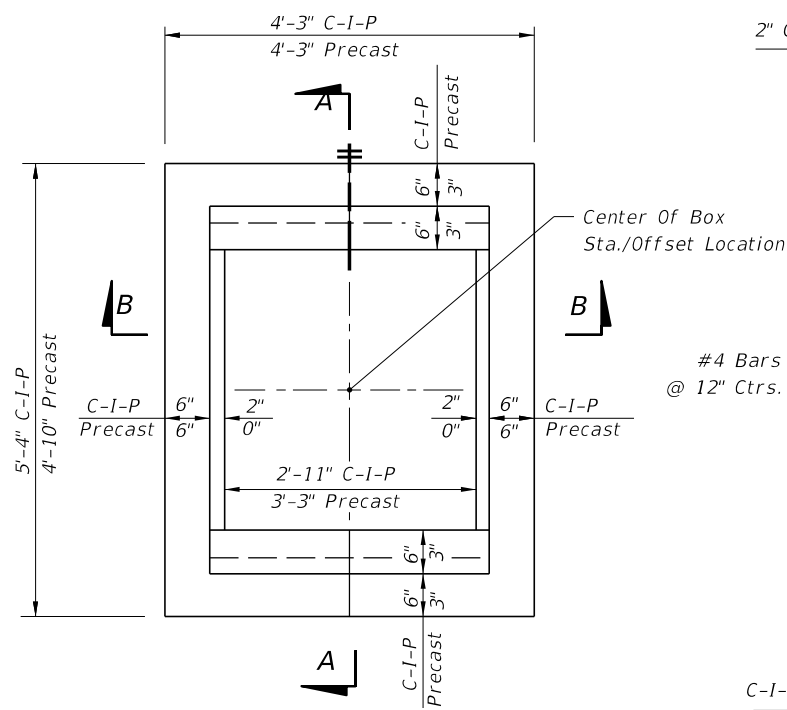

PLAN
(CAST-IN-PLACE INLET SHOWN WITHOUT GRATE; PRECAST INLET SIMILAR)

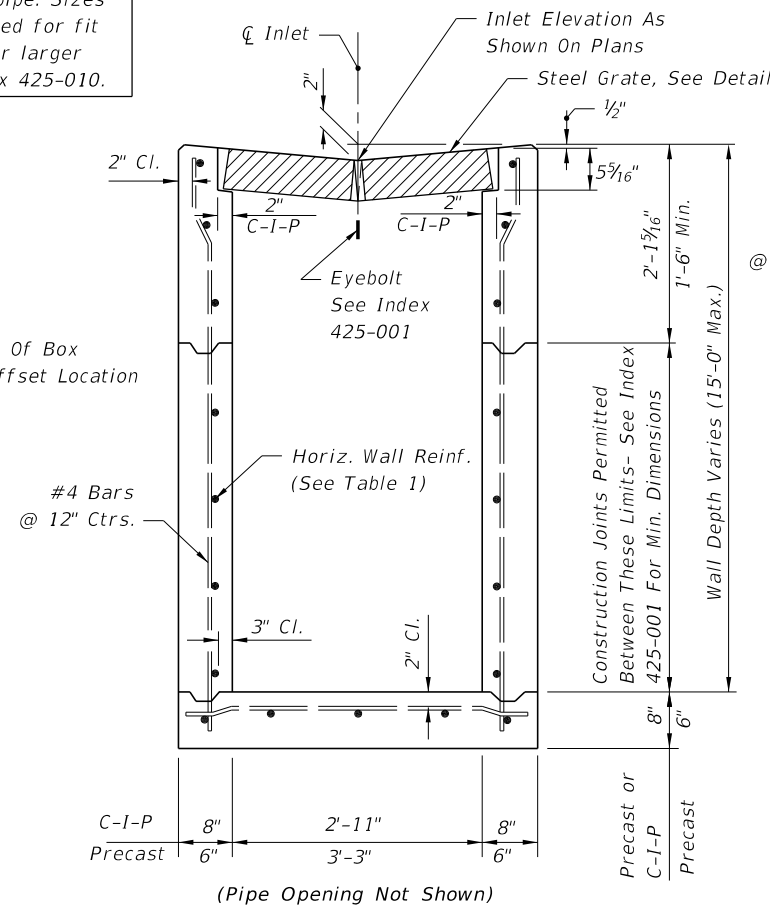

SECTION BB
(CAST-IN-PLACE INLET SHOWN PRECAST INLET SIMILAR)

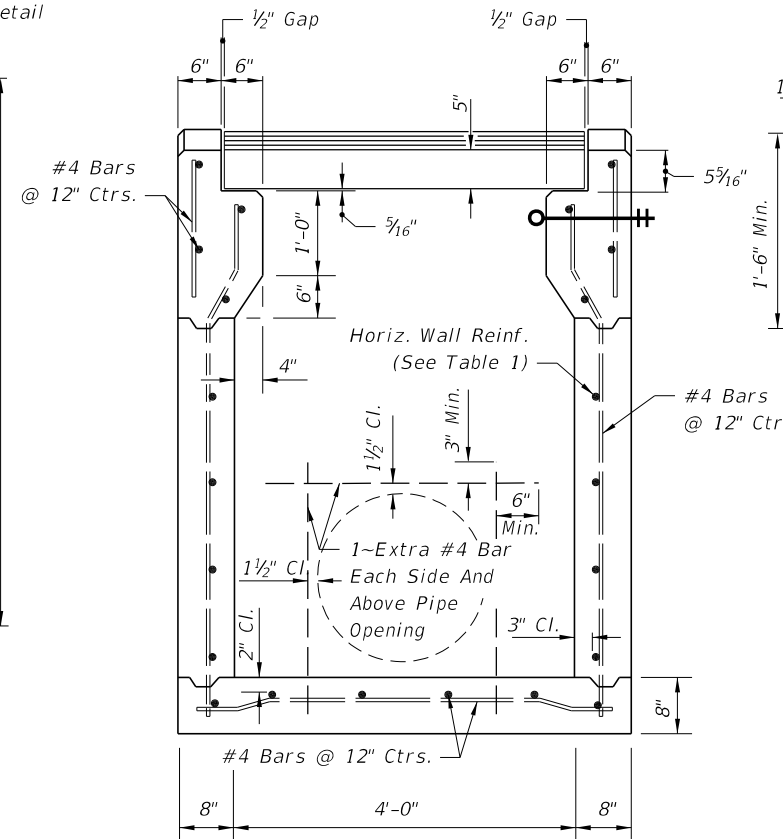

(Pipe Opening Shown)
SECTION AA
(CAST-IN-PLACE INLET)

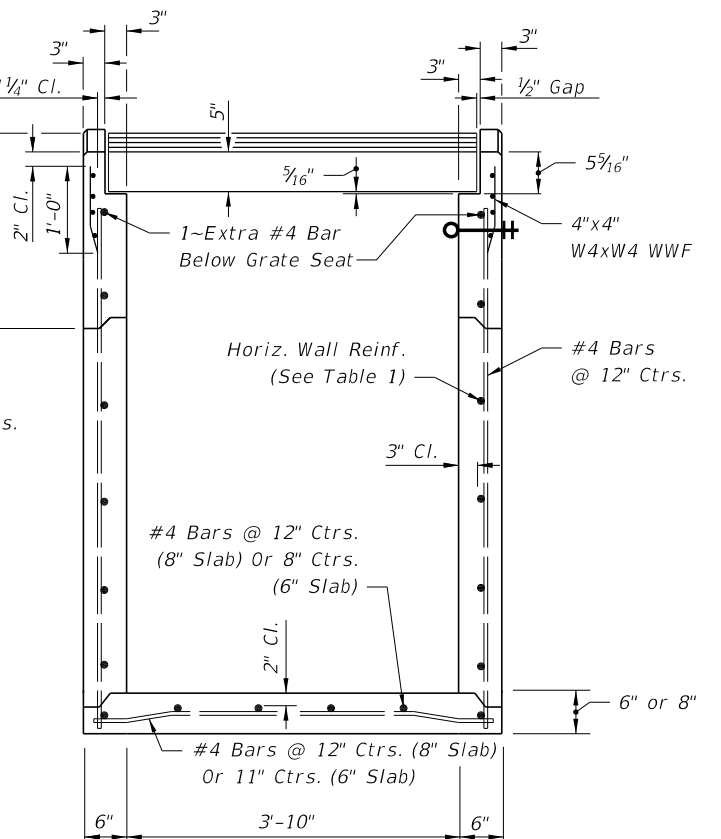

(Pipe Opening Not Shown)
SECTION AA
(PRECAST INLET)

9/18/2018 2:45:45 PM

LAST REVISION	DESCRIPTION:
11/01/17	

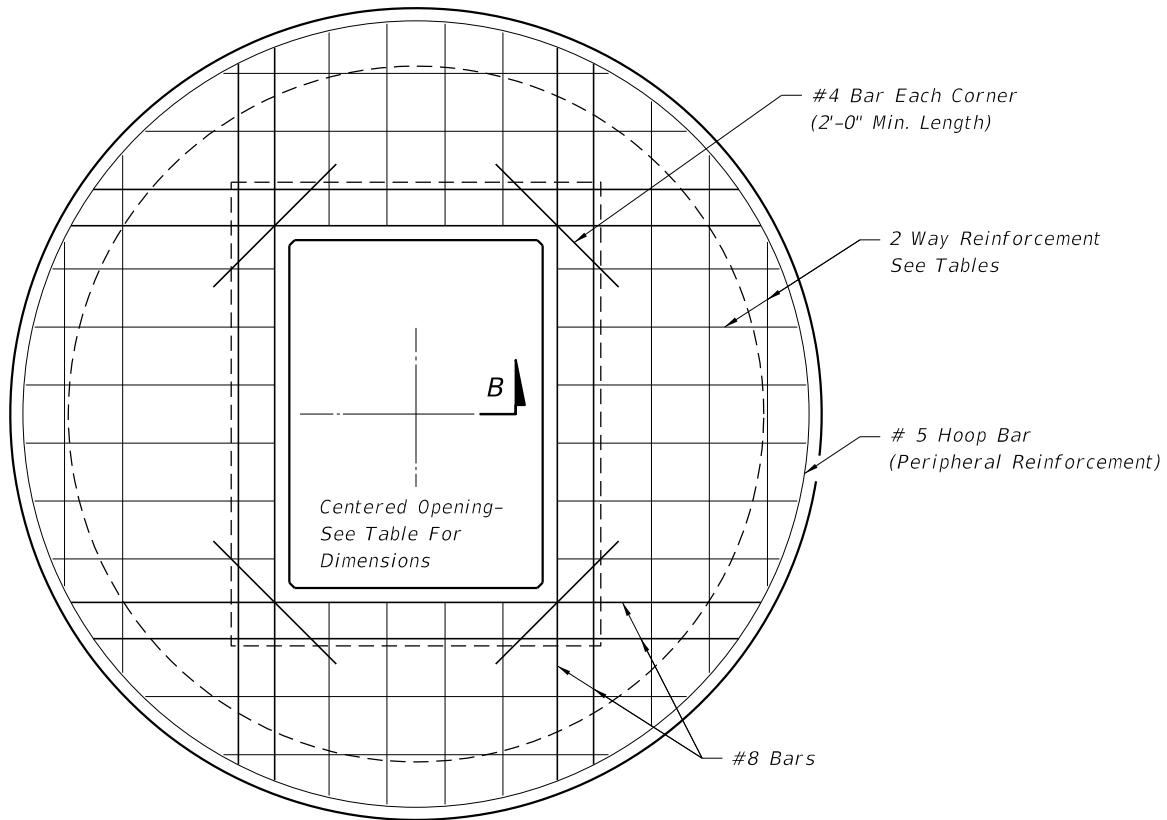
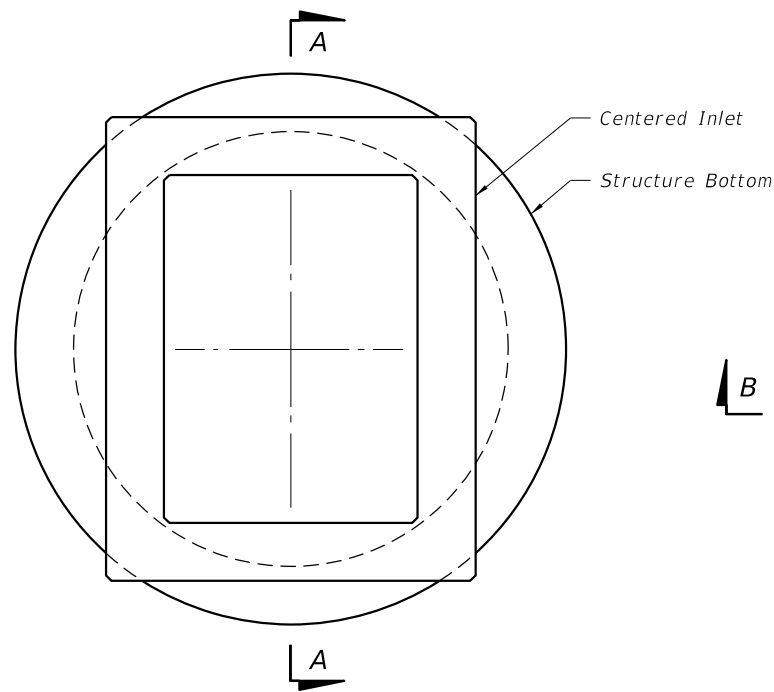

TOP SLAB REINFORCING DIAGRAM

TOP SLAB OPENINGS		
DIAMETER	OPENING SIZE	
	MIN.	MAX.
5'-0" To 8'-0"	2'-11" x 4'-0"	3'-3" x 3'-10"

TOP SLAB REINFORCING SCHEDULE	
SCHEDULE	GRADE 60 (BAR) OR 65 KSI & 70 KSI (WIRE FABRIC) In. ² /ft.
A	0.20
B	0.24
C	0.37
D	0.53
E	0.73
F	1.06
G	1.45

TOP SLAB WITH CENTERED OPENING		
SLAB DEPTH	SLAB THICKNESS	REINFORCING (2 WAYS) SCHEDULE
SIZE: 5'-0"		
≥0.5' < 30'	9½"	C
30'-40'	9½"	D
SIZE: 6'-0"		
0.5' < 8'	9½"	B
8' < 18'	9½"	C
18' < 30'	9½"	D
30' < 37'	9½"	E
37'-40'	9½"	G
SIZE: 8'-0"		
≥0.5' < 9'	11½"	C
9' < 15'	11½"	D
15' < 23'	11½"	E
23' < 33'	11½"	E
33'-40'	11½"	G

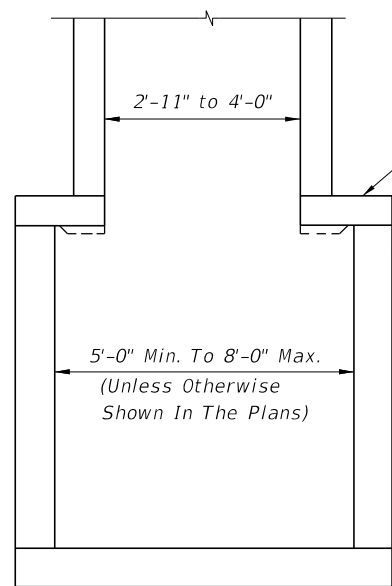

SECTION AA

Top Slab With Centered Opening
Round Structure Bottom See Index 425-010 For Structure Bottom Details and Hole Reinforcement.

9½" For 5'-0"/6'-0" Structure Bottoms
11½" For 8'-0" Structure Bottoms

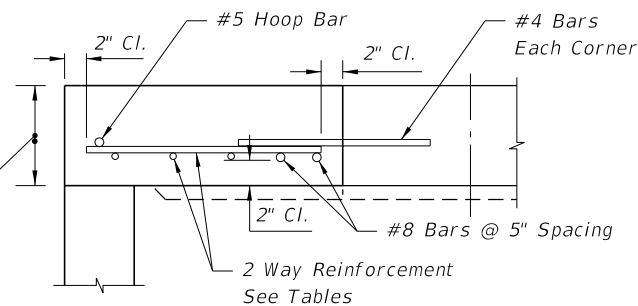

SECTION BB

ALT. A STRUCTURE BOTTOM FOR INLET TYPE V

9/18/2018 2:45:45 PM

LAST REVISION 11/01/17	DESCRIPTION:
---------------------------	--------------



FY 2019-20
STANDARD PLANS

GUTTER INLET TYPE V

INDEX
425-041

SHEET
2 of 2