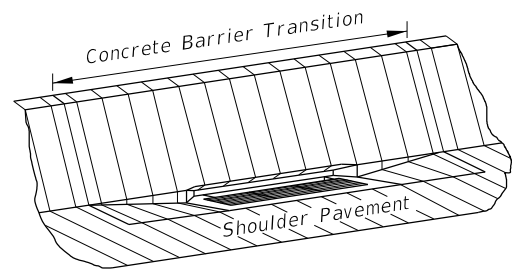

TABLE 1: HORIZONTAL WALL REINFORCING SCHEDULE

WALL DEPTH	SCHEDULE	AREA (in. ² /ft.)	MAX. BARS	SPACING WWF
0'-3'	A12	0.20	12"	8"
3'-6'	A6	0.20	6"	5"
6'-9'	B5.5	0.24	5½"	5"
9'-15'	C6.5	0.37	6½"	6"



ISOMETRIC VIEW

GENERAL NOTES:

- Where called for in the Plans, use this inlet in conjunction with Median Barrier per Index 521-001.

Inlet Descriptions:
Type 1: Inlet on one side of Median Barrier
Type 2: Inlet on both sides of Median Barrier
- For grate details, see Index 425-040. The parallel bar grate shall be used unless the reticuline grate is called for in the plans. The reticuline grate shall be specified where bicycle traffic is anticipated. Used in areas of occasional pedestrian traffic. Not suitable for use in pedestrian traffic or bicycle way.
- All exposed edges and corners shall be 3/4" chamfer or tooled to 1/4" radius.
- For standard Median Barrier dimensions and requirements, see Index 521-001.
- Inlet wall reinforcing is Grade 60 #4 bars. The horizontal wall reinforcing must be positioned 3" from the inside face unless otherwise shown. Per Index 425-001, the equivalent area of welded wire fabric is permitted.
- Barrier reinforcing is Grade 60 #4 bars or #5 bars, as required to match the stirrups and longitudinal steel of the adjacent Concrete Barrier per Index 521-001. Barrier reinforcing steel cover may be either 2" or 2½" as needed to match the adjacent barrier reinforcing cover, unless otherwise shown. Match the stirrup spacing of the adjacent barrier. Run Longitudinal steel bars over the full length of the Concrete Barrier Transition and run continuously with the longitudinal steel of the adjacent barriers; use lap splices as required.
- For supplemental details see Index 425-001.
- All dimensions are for both precast and cast-in-place inlets unless otherwise noted.
- Inlets to be paid for under the contract unit price for Inlets (Median Barrier Type_), EA. Concrete Barrier to be paid for under the contract unit price for Concrete Barrier, LF.
- Bond Breaker: One layer of ASTM D6380 Class S, Type III organic felt between inlet and barrier, including footings.

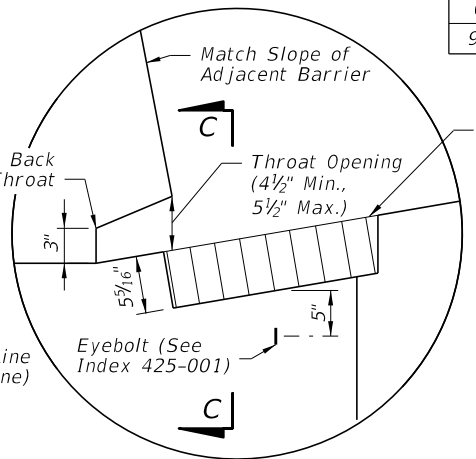

INLET DETAIL

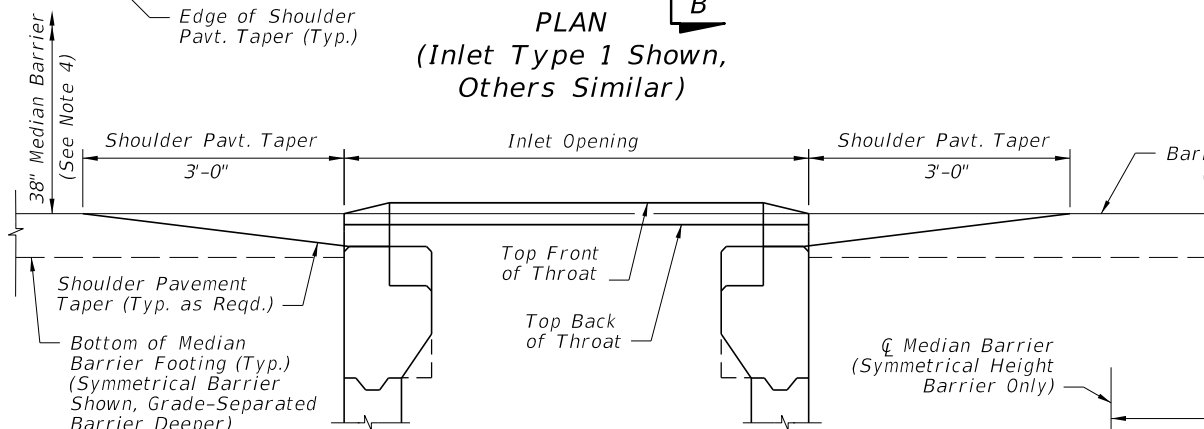

ELEVATION - VIEW C-C (Grate Not Shown for Clarity)

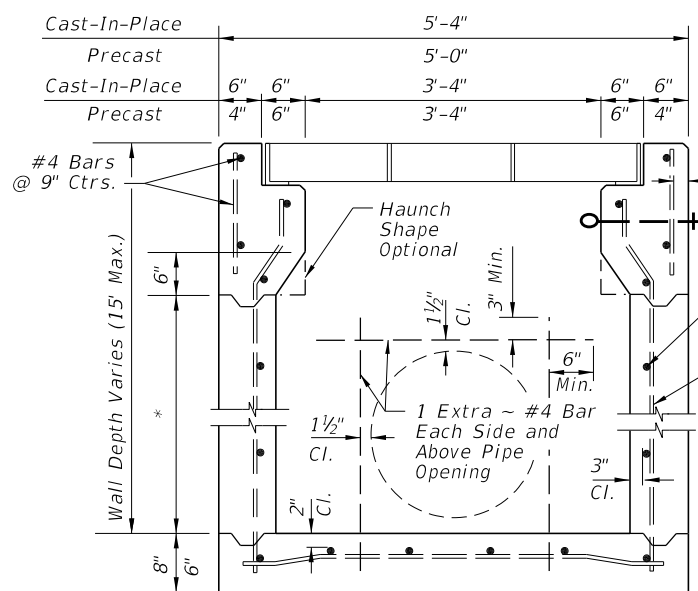

SECTION A-A (Pipe Opening Shown)

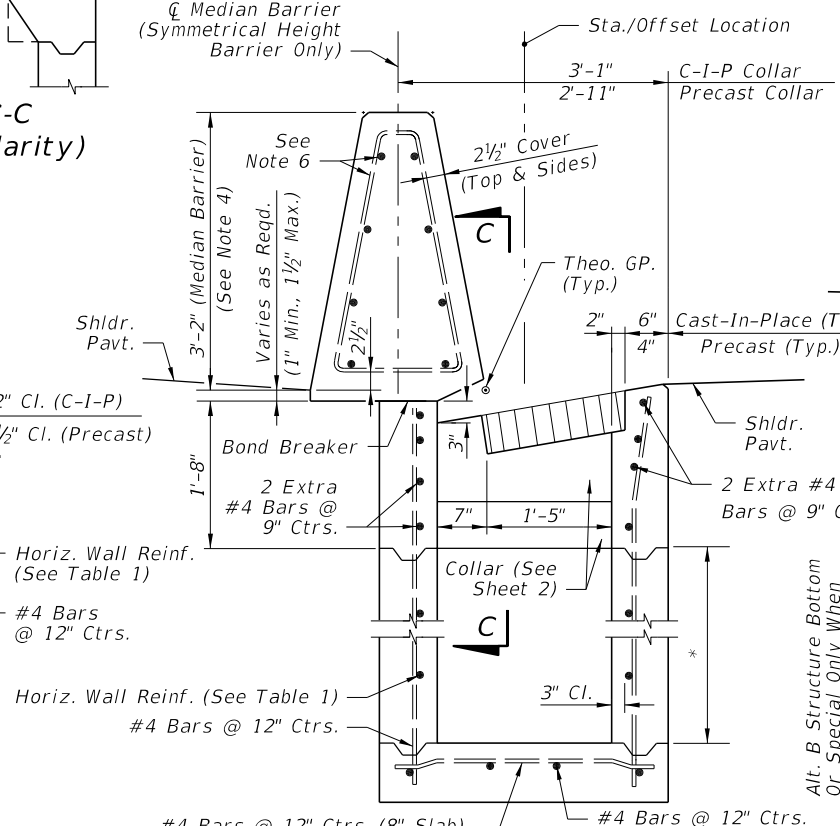

SECTION FOR INLET TYPE 1 (SYMMETRICAL HEIGHT BARRIER ONLY)

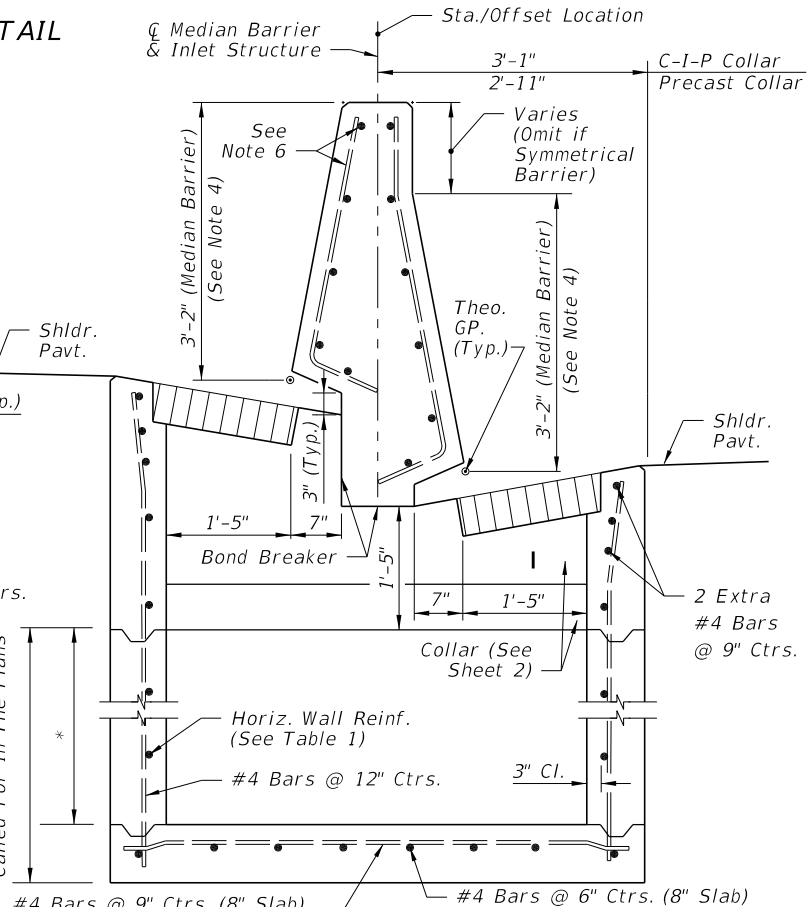

SECTION FOR INLET TYPE 2 (GRADE-SEPARATED BARRIER SHOWN, SYMMETRICAL HEIGHT BARRIER SIMILAR)

* Const. Joint Permitted Between These Limits See Index 425-001 For Min. Dimensions

SECTION B-B (Pipe Opening Not Shown)

11/25/2019 12:40:52 PM

LAST REVISION 11/01/17	DESCRIPTION:	FDOT FY 2019-20 STANDARD PLANS	MEDIAN BARRIER INLETS TYPES 1 AND 2	INDEX 425-030	SHEET 1 of 2
---------------------------	--------------	--------------------------------------	-------------------------------------	------------------	-----------------

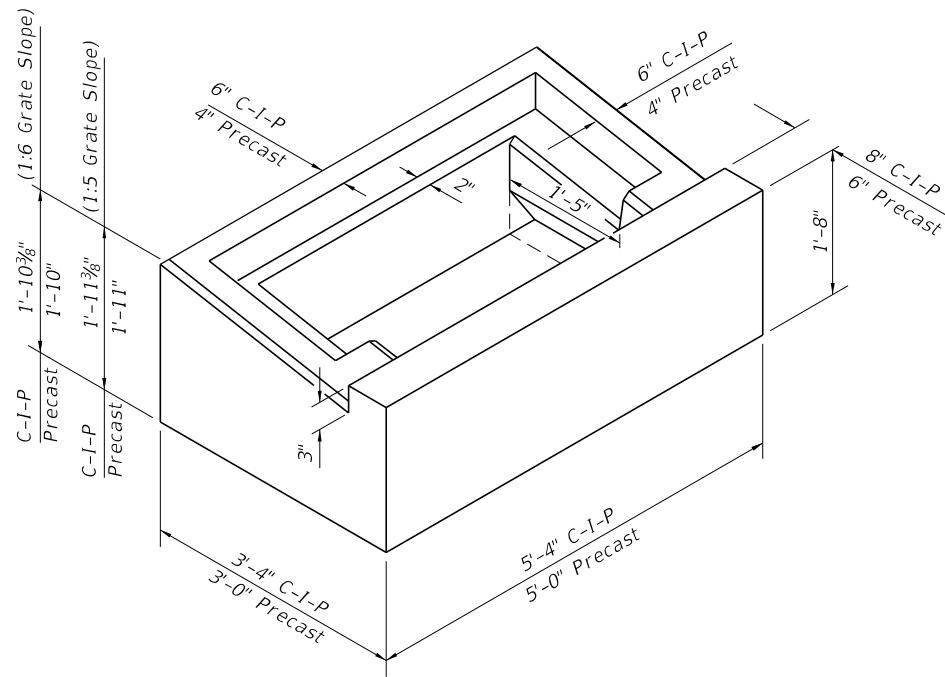

ISOMETRIC VIEW OF INLET COLLAR (TYPE 1)

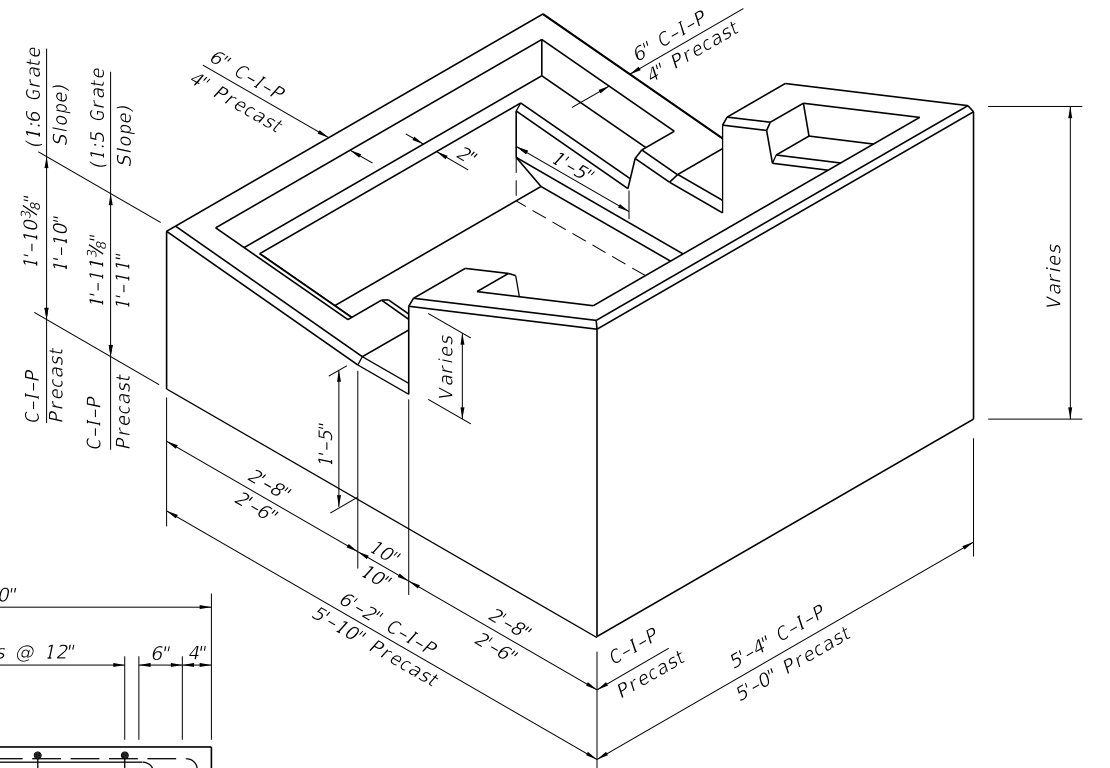

ISOMETRIC VIEW OF INLET COLLAR (TYPE 2)

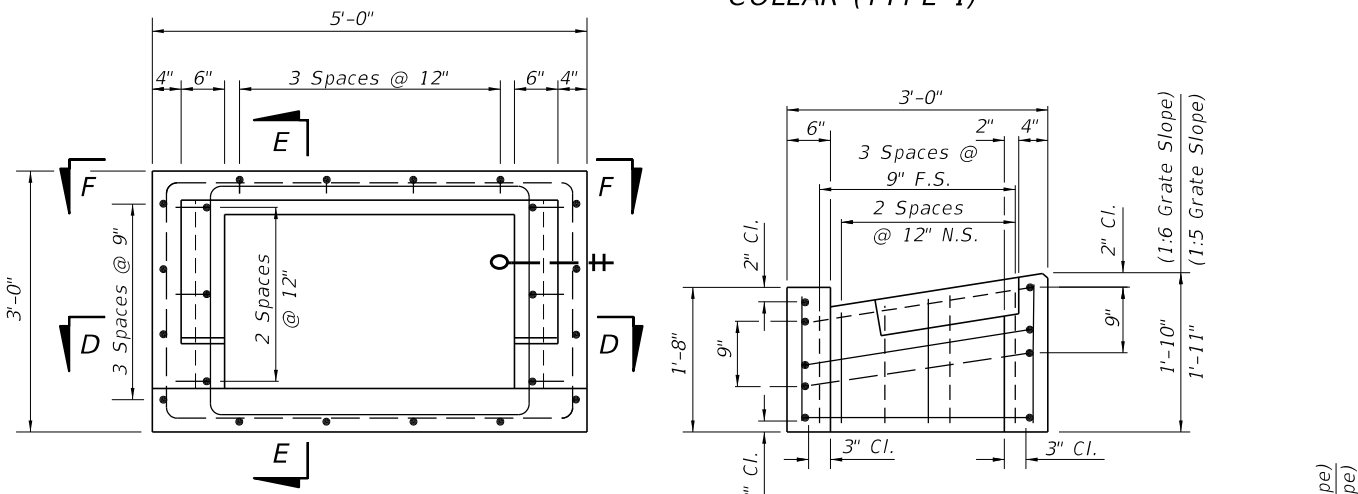

TOP VIEW OF INLET COLLAR WITHOUT GRATE

SECTION EE

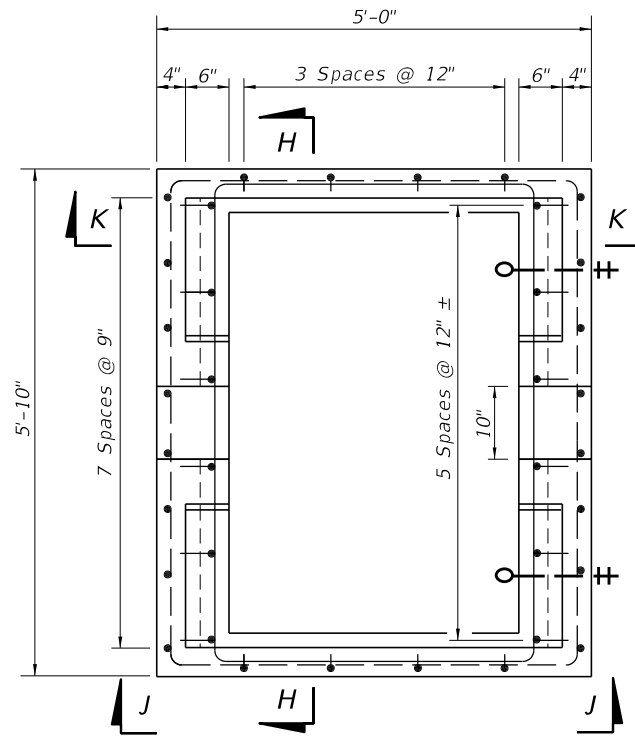

TOP VIEW OF INLET COLLAR WITHOUT GRATE

SECTION HH

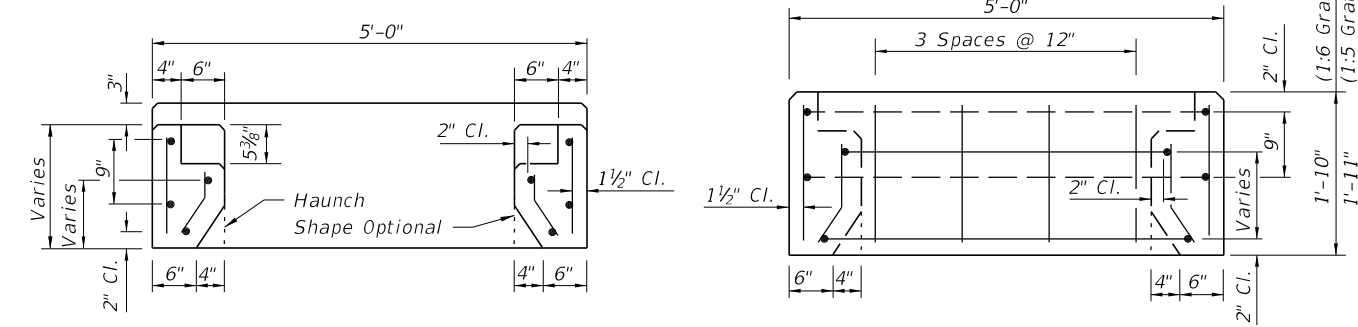

SECTION DD

VIEW FF

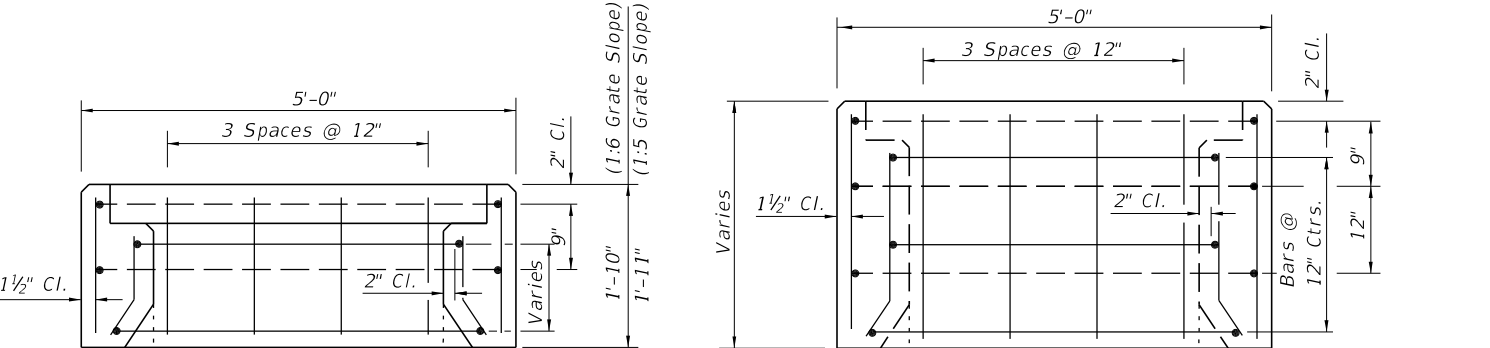

VIEW KK

VIEW JJ

PRECAST COLLAR REINFORCING DETAILS (TYPE 1)
(C-I-P COLLAR REINFORCING DETAILS SIMILAR)

PRECAST COLLAR REINFORCING DETAILS (TYPE 2)
(C-I-P COLLAR REINFORCING DETAILS SIMILAR)

10/24/2018 8:51:09 AM

LAST REVISION 11/01/17	DESCRIPTION:
---------------------------	--------------