

TOP VIEW

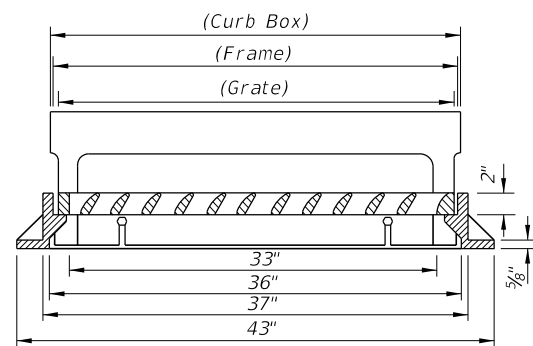

LONGITUDINAL SECTION

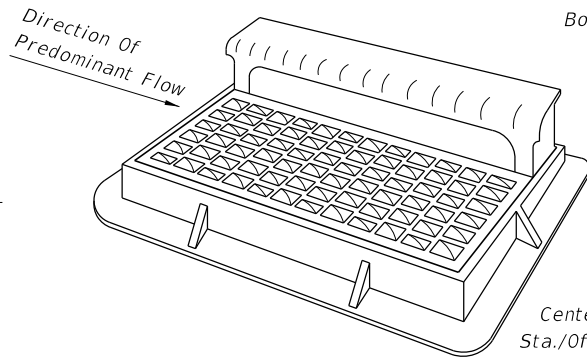

#5 Bars Top #6 Bars Bottom 12" Returns, Each (Min.)

Center of Opening Sta./Offset Location

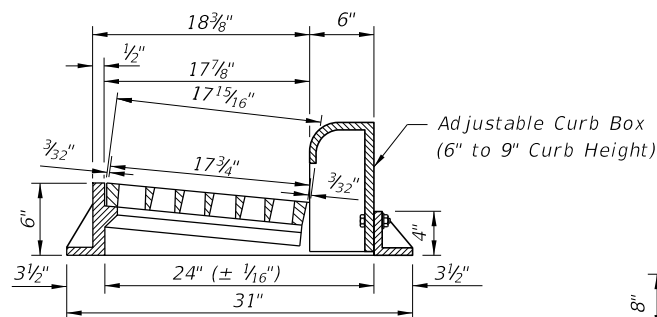

TRANSVERSE SECTION

FRAME AND GRATE

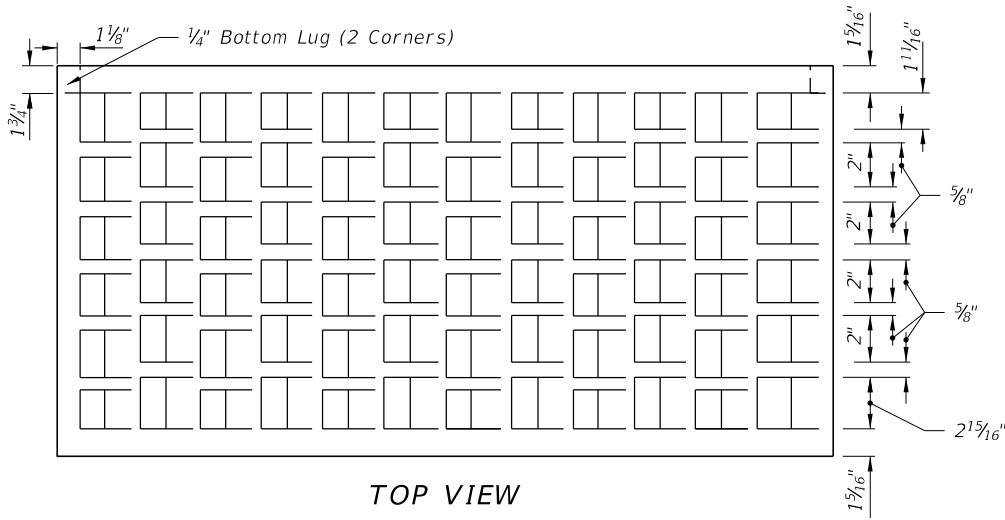

TOP VIEW

Approximate Debris Free Capacity (0.02 Pavement Cross Slope)

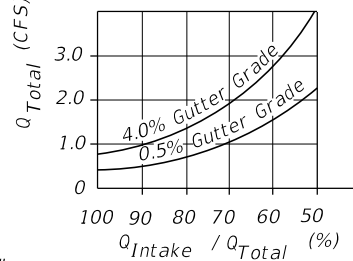

EFFICIENCY CURVE

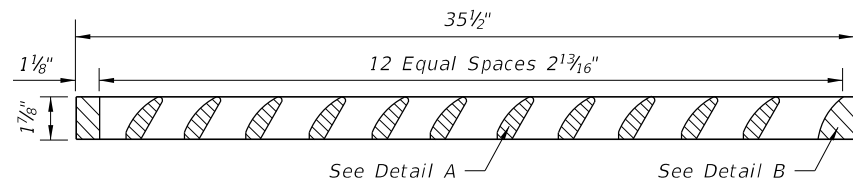

SECTION

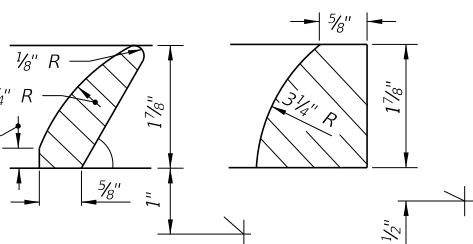

DETAIL A DETAIL B

GRATE DETAIL

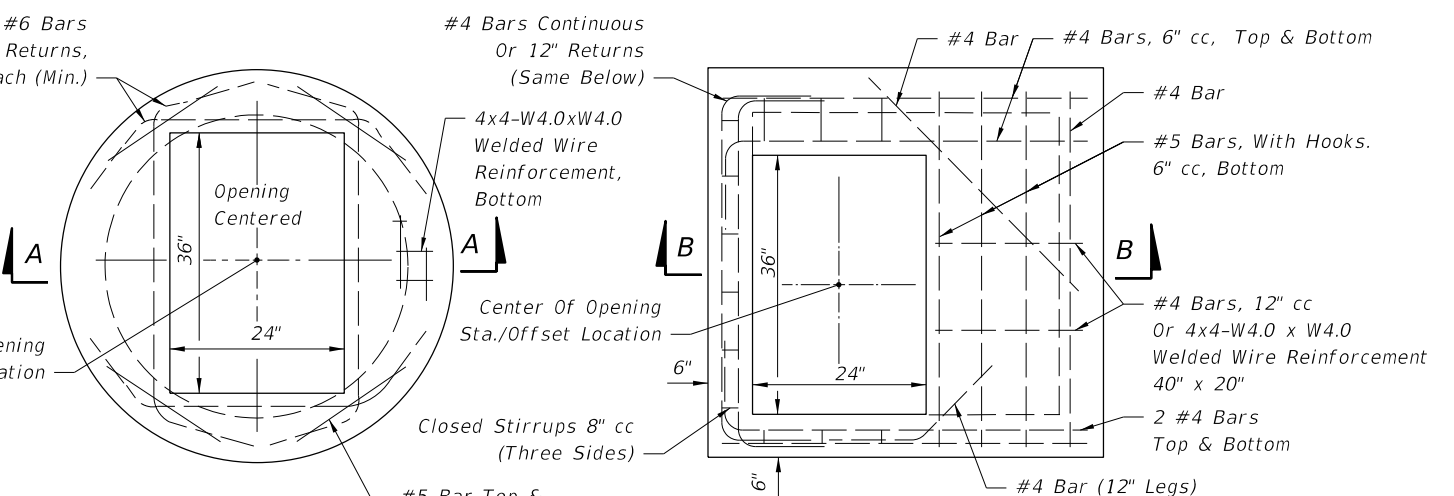

TOP VIEW

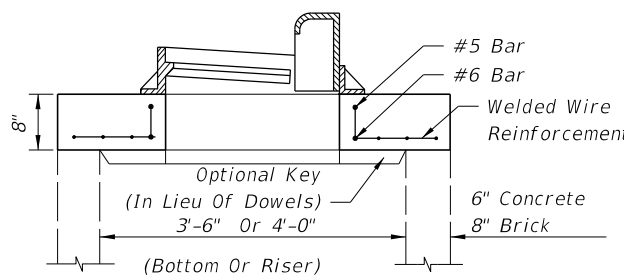

SECTION AA (SEE NOTE 6 BELOW)

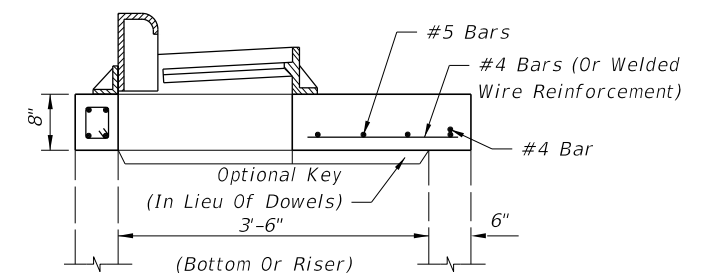

SECTION BB (SEE NOTE 6 BELOW)

TOP SLABS

GENERAL NOTES

1. This inlet is primarily intended for locations with light to moderate flows where right of way does not permit the use of throated Curb Inlets Types 1 through 6. The typical application is on curb returns to city streets. The inlet grate is suitable for pedestrian and bicycle traffic.
2. This inlet to be located outside of curb ramp area in vertical faced curbs such as Curb and Gutter Type F. Grate shall be oriented with vanes directed toward Predominant flow.
3. For structure bottoms see Index 425-010. For supplemental details see Index 425-001.
4. All steel in slab tops shall have 1 1/4" minimum cover unless otherwise shown. Tops shall be either cast-in-place or precast concrete.
5. For Alternate B applications, top slab openings shall be placed such that 2 edges of inlet frame will be located directly above bottom wall or riser wall.
6. When used on a structure with dimensions larger than those detailed above and risers are not applied, the top slab shall be constructed using Index 425-010 with the slab opening adjusted to 24"x36". The "Special Top Slab" on Index 425-010 is not permitted.
7. Frame may be adjusted with one to six courses of brick.
8. Vaned grates with approximately equal openings will be permitted that satisfy AASHTO HL-93 loading. Grates shall be reversible, right or left.

9/18/2018 2:37:38 PM

LAST REVISION 11/01/17	DESCRIPTION:
---------------------------	--------------



FY 2019-20
STANDARD PLANS

CURB INLET TOP TYPE 9

INDEX
425-024

SHEET
1 of 1