

MODIFICATION WHEN USED AS A MANHOLE

#6 Bars ACI Std. Hooks Required Each End of Straight Bars and Right End of Bent Bars: 180° Hooks, Canted 60°(+), on Odd Bars; 90° Hooks, Down, on Even Bars Numbered from Throat Side.

Const. Joints Permitted Between These Limits See Index 425-001 For Minimum Dimensions.

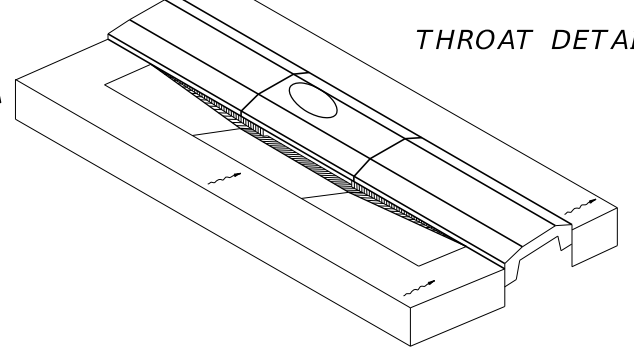

HORIZONTAL WALL REINFORCING SCHEDULE (TABLE 1)

WALL DEPTH	SCHEDULE	AREA (in. ² /ft.)	MAX. SPACING	
			BARS	WWF
0' - 6'	A12	0.20	12"	8"
6' - 10'	A6	0.20	6"	5"
10' - 13'	A4	0.20	4"	3"
10' - 15'	B5.5	0.24	5 1/2"	5"

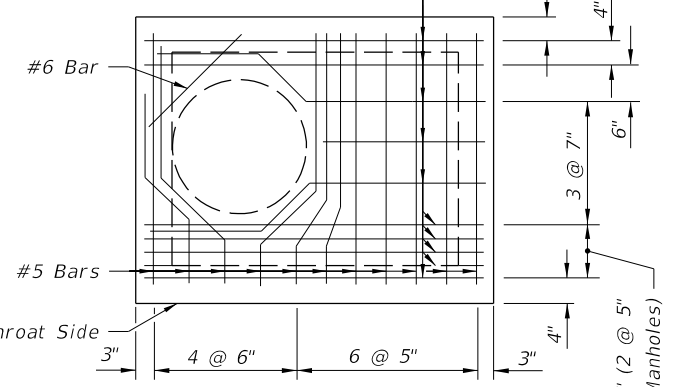

REINFORCING STEEL DIAGRAM TOP SLAB OF INLETS

#6 Bars - See Throat Detail and Reinforcing Diagram for Hook Arrangement

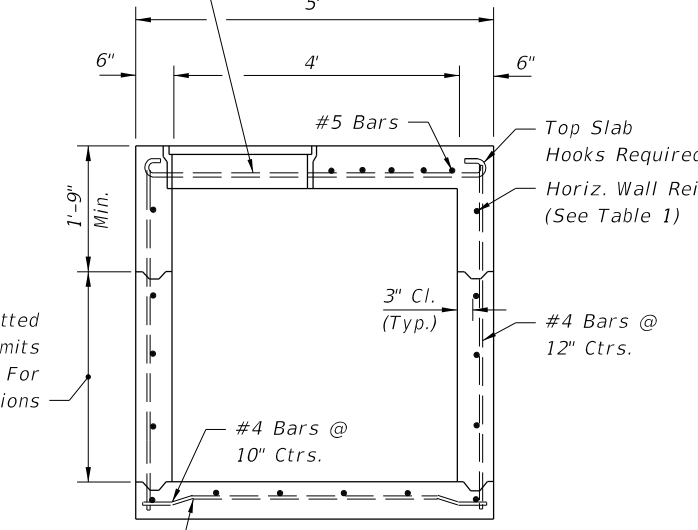

SECTION BB

For Bottom Slab Rebar Embedment Options See Optional Construction Joints, Index 425-001

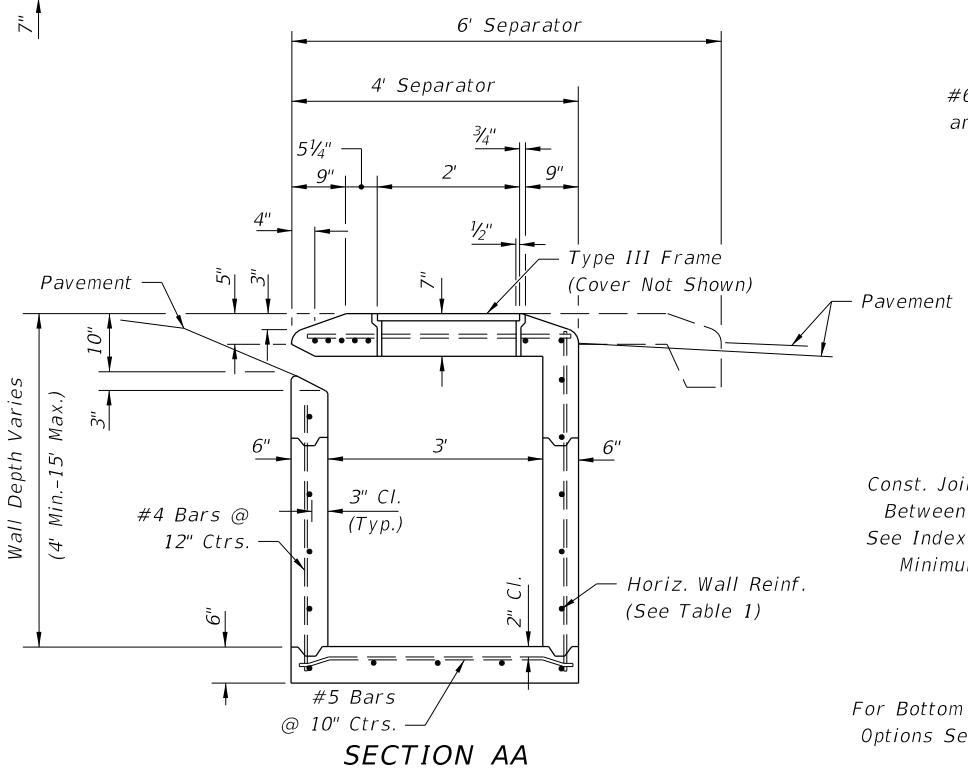
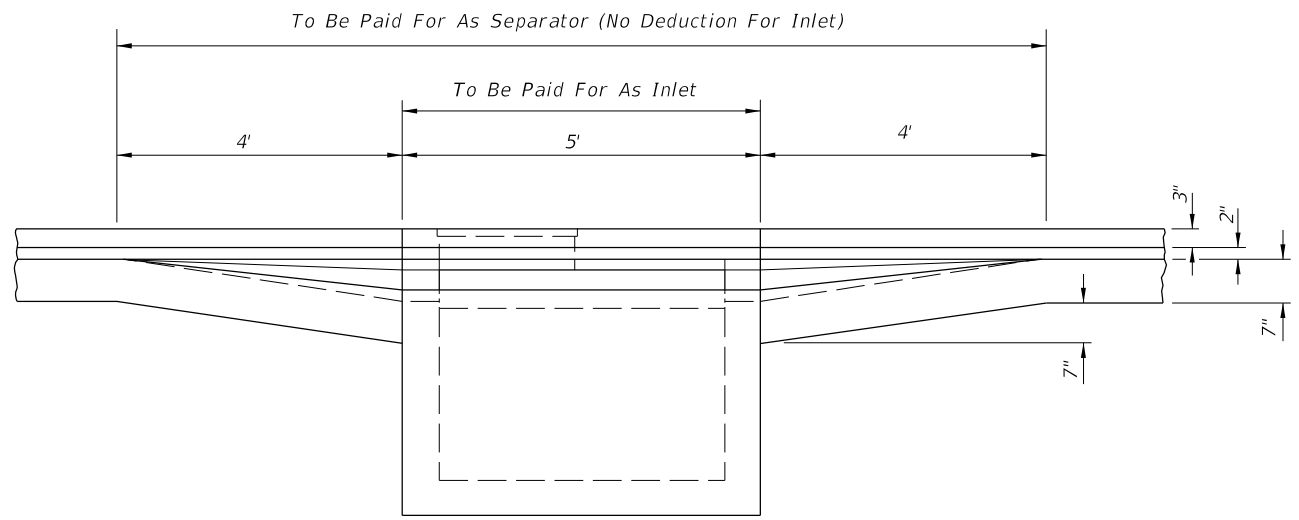

SECTION AA

Const. Joints Permitted Between These Limits See Index 425-001 For Minimum Dimensions

GENERAL NOTES

1. This inlet is used in Traffic Separators Types I and II; or, in separators constructed with Curbs Types A, B and E and sidewalk paving, which cannot accommodate Inlets Types 1, 2, 3, 4, 5, or 6. Use of this Inlet on through traffic side of the separator is not permitted in medians with Curb Types A and B. Locate inlet outside of pedestrian way.
2. All reinforcing to be Grade 60 bars with 2" min. cover unless otherwise shown. See Index 425-001 for equivalent area of welded wire fabric. Cut or bend bars out of way of pipe when necessary. Bars to clear pipe by 1 1/2"
3. Recommended maximum pipe sizes are 24" longitudinal and 30" transverse. For larger pipe, inlets with Alt. B bottoms, Index 425-010 are recommended.
4. For supplementary details see Index 425-001.
5. All dimensions are for both precast and cast-in-place inlets unless otherwise shown.
6. Inlet to be paid for under the contract unit price for Inlets (Curb) (Type 7), Each.

9/18/2018 2:36:06 PM