

PLAN (INLET TYPE 2 SYMMETRICAL ABOUT CL)

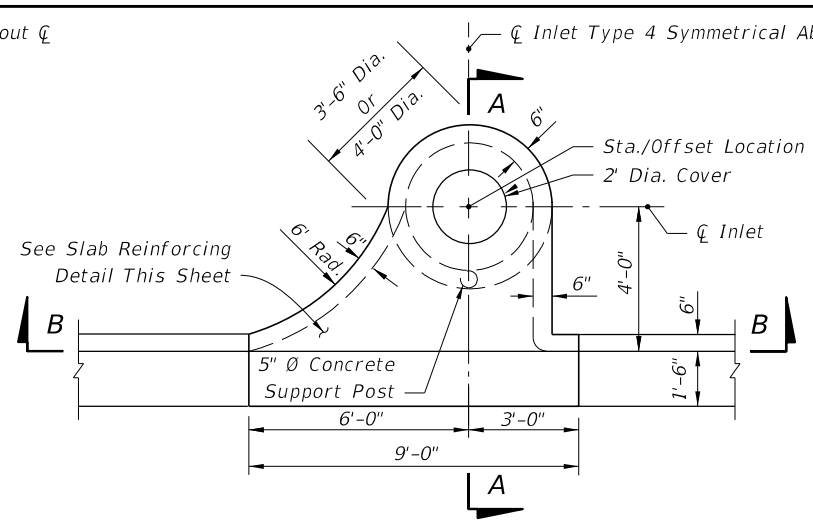

PLAN (INLET TYPE 4 SYMMETRICAL ABOUT CL)

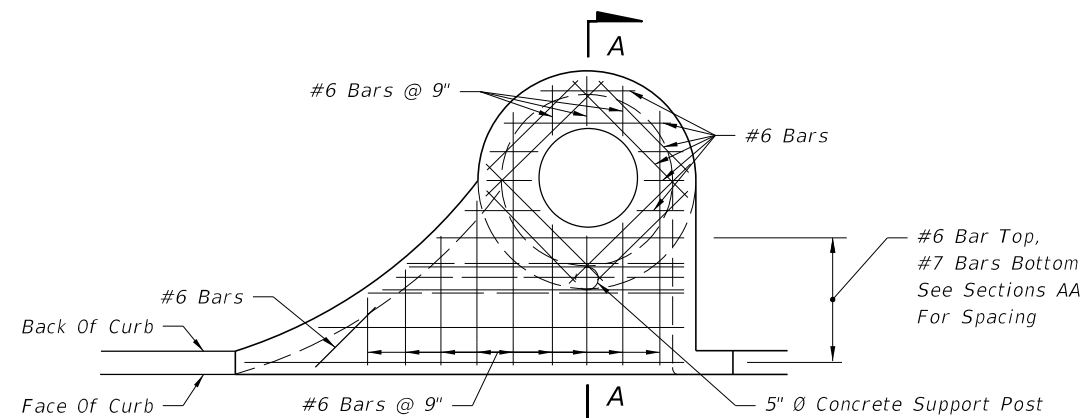

INLETS TYPES 1 AND 3

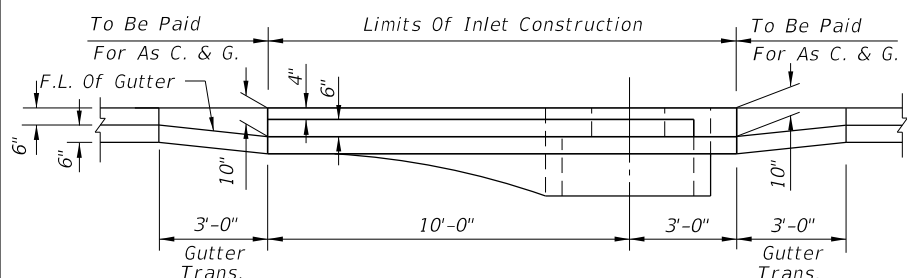

SECTION BB (INLET TYPE 2 SYMMETRICAL ABOUT CL)
INLETS TYPES 1 AND 2

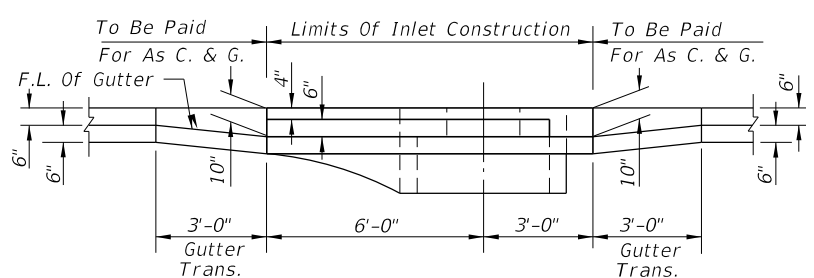

SECTION BB (INLET TYPE 4 SYMMETRICAL ABOUT CL)
INLETS TYPES 3 AND 4

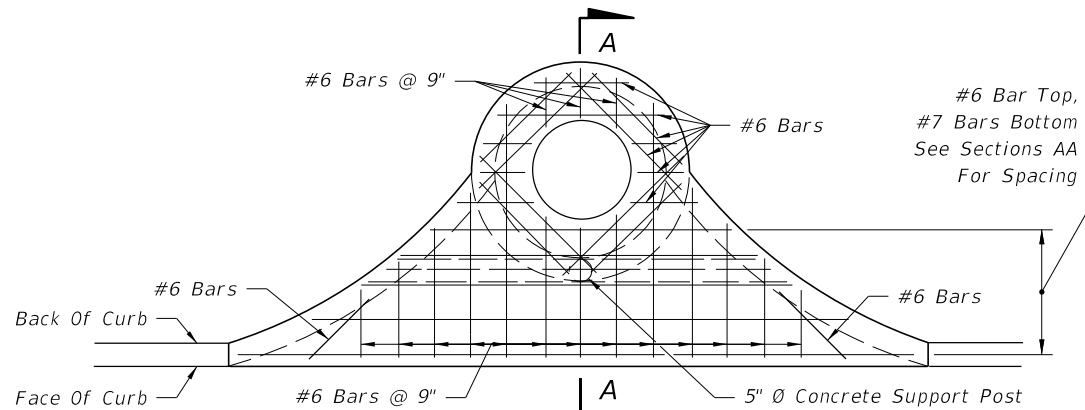

INLETS TYPES 2 AND 4
SLAB REINFORCING

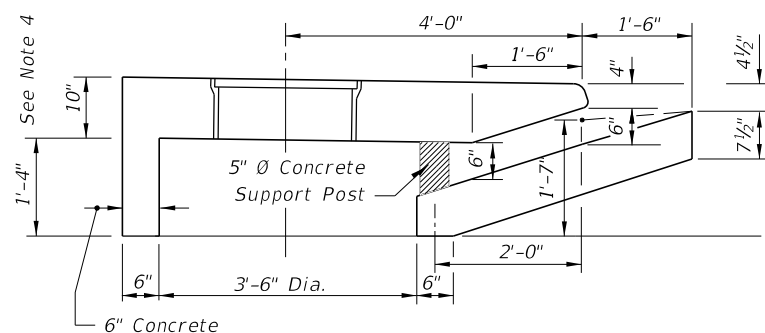

DIMENSIONAL SECTION

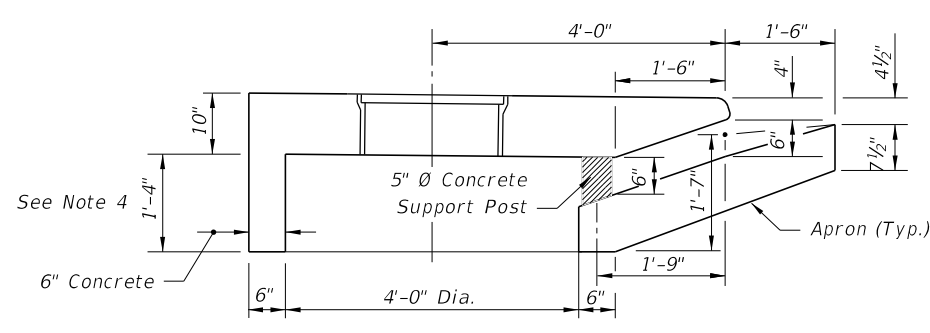

DIMENSIONAL SECTION

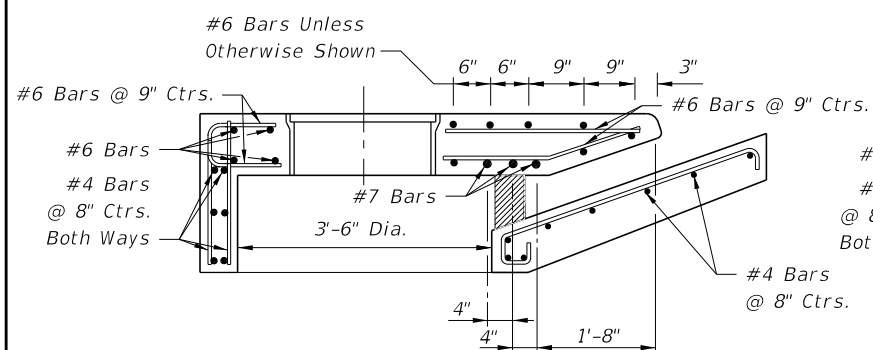

REINFORCING SECTION
3'-6" DIA. STRUCTURE BOTTOM (SECTION AA)

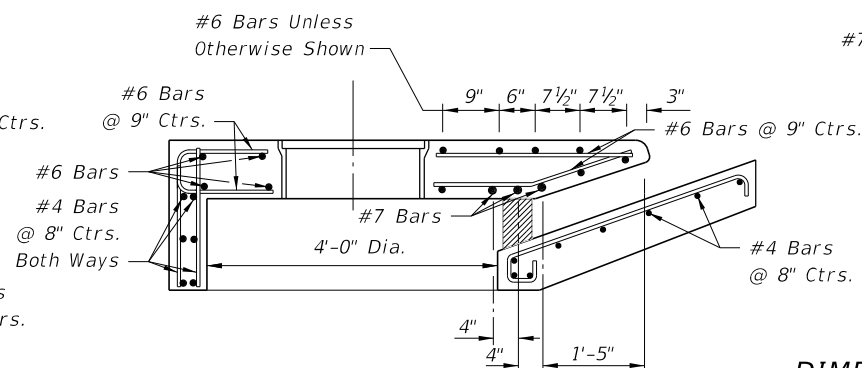

REINFORCING SECTION
4'-0" DIA. STRUCTURE BOTTOM (SECTION AA)

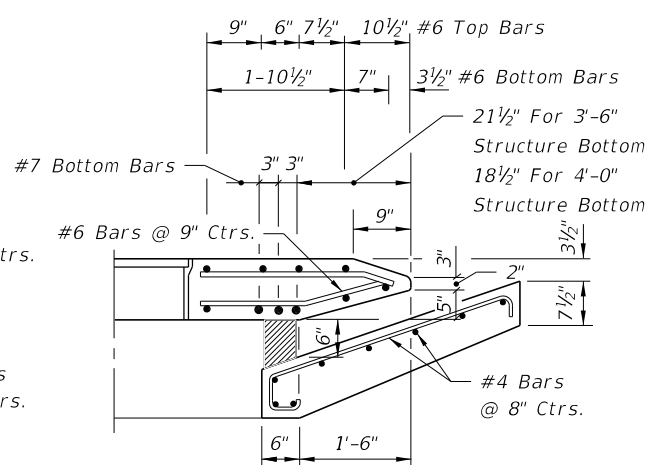

DIMENSION & REINFORCING HALF SECTION
TYPES A & E CURB (HALF SECTION AA)
(TYPE E GUTTER SHOWN)

GENERAL NOTES

1. The finished grade and slope of the inlet tops are to conform with the finished cross slope and grade of the proposed sidewalk and/or border.
2. When inlets are to be constructed on a curve, refer to the plans to determine the radius and, where necessary, modify the inlet details accordingly. Bend steel when necessary.
3. All steel in inlet top shall have 1/4" minimum cover unless otherwise shown. Inlet tops shall be either cast-in-place or precast concrete.
4. For precast units the rear wall and apron may be precast as a separate piece from the top slab. Provide a minimum of 7 ~ #4 dowels in accordance with Index 425-001 "OPTIONAL CONSTRUCTION JOINTS".
5. For supplemental details see Index 425-001.
6. Only round concrete support post will be acceptable.
7. These inlets are designed for use with standard curb and gutter Types E and Type F. Locate inlet outside of pedestrian crosswalks.
8. For structure bottoms see Index 425-010.
9. Inlet to be paid for under the contract unit price for inlets (Curb) (Type_), Each.

TRANSVERSE SECTIONS FOR INLETS TYPES 1, 2, 3 & 4

9/18/2018 2:34:43 PM

LAST REVISION 11/01/17	DESCRIPTION:	FY 2019-20 STANDARD PLANS	CURB INLET TOPS TYPES 1, 2, 3 AND 4	INDEX 425-020	SHEET 1 of 1
---------------------------	--------------	------------------------------	-------------------------------------	------------------	-----------------