

PLAN VIEW (CASE 1)

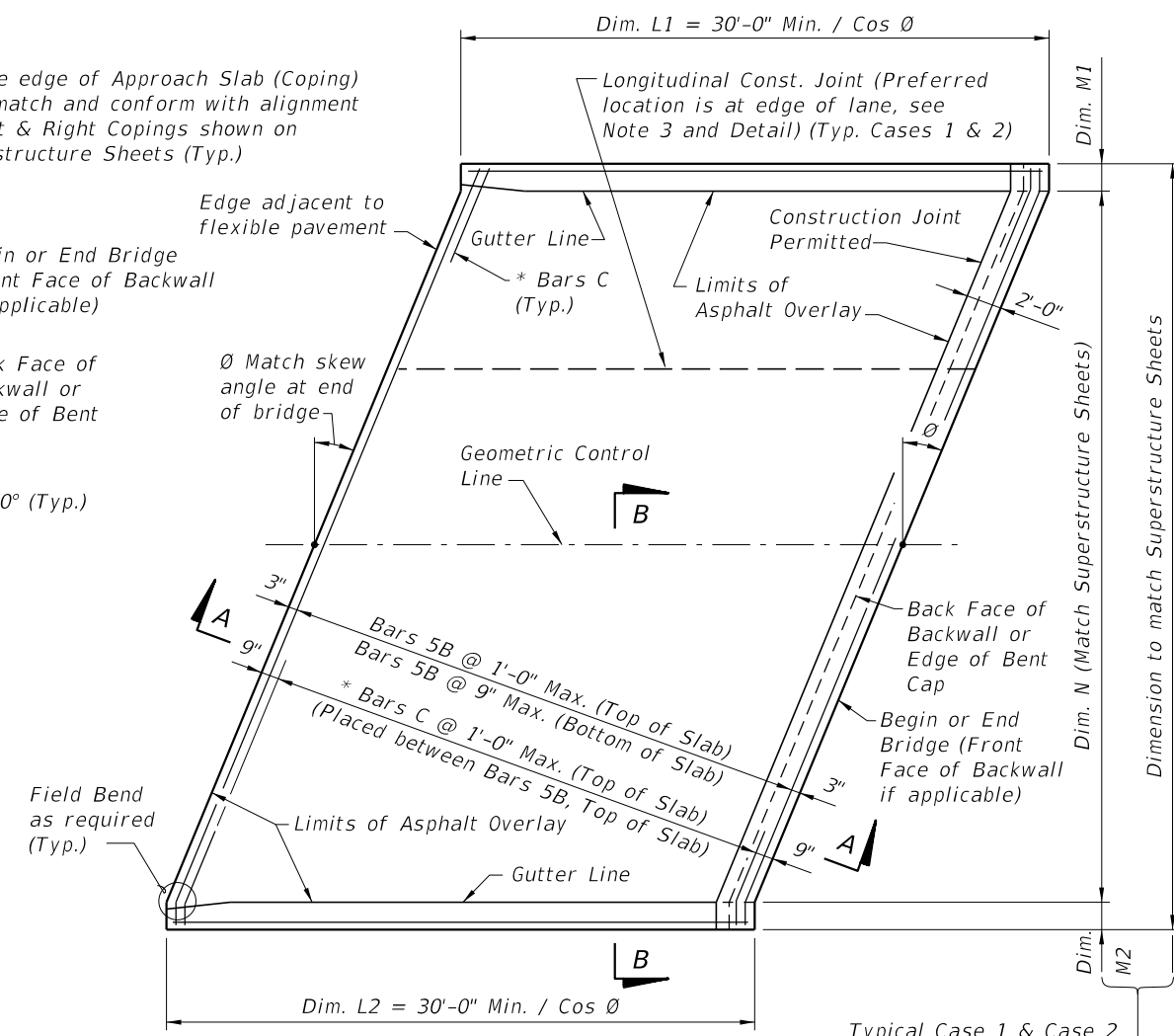

PLAN VIEW (CASE 2)

* NOTE: Bars C are required as shown when the 36" or 42" Single-Slope Traffic Railings, or the Traffic Railing/Noise Wall, are used at the edge of the Approach Slab.

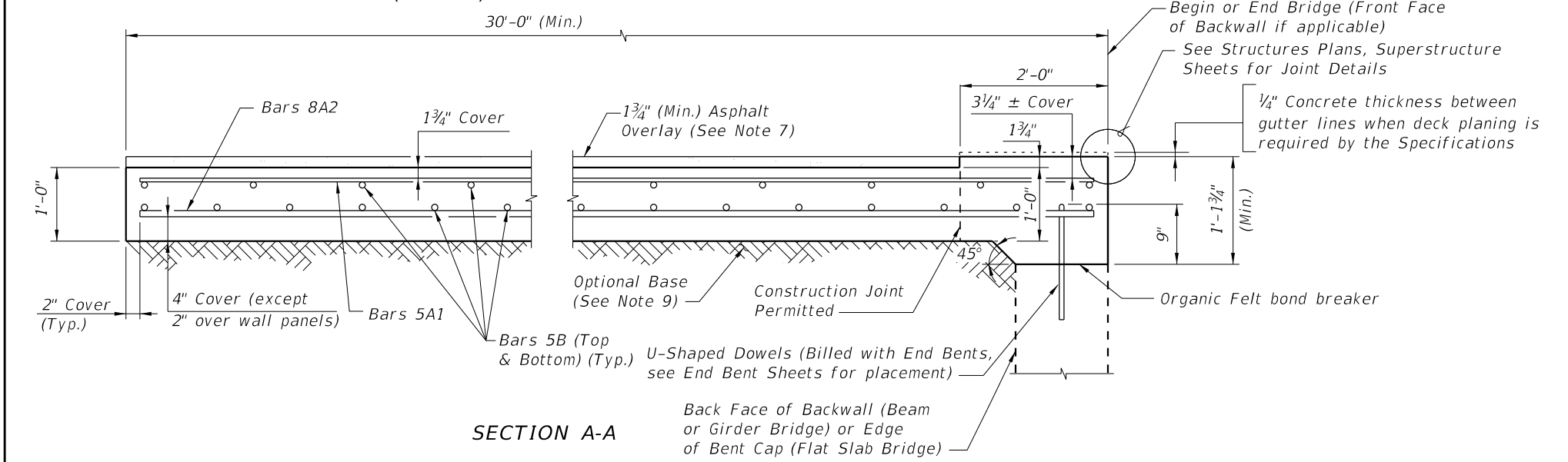

SECTION A-A

GENERAL NOTES

- SURFACE TREATMENT:** As an option to Class 4 Floor Finish (Bridge Floor Grooving) per Section 400 a hand tined or heavy broomed finish may be permitted on the concrete portion of the riding surface. Sidewalk areas shall receive a broomed finish. The top surface of the concrete beneath the asphalt overlay shall be raked.
- CONDUIT:** If required, see Structures Plans for Conduit Details.
- When a longitudinal construction joint is necessary or allowed by the Engineer, the transverse steel shall be extended as shown in the Longitudinal Construction Joint Detail.
- The plan view for CASE 1 applies when the skew angle (θ) = 0° . Relevant details also apply to CASE 2.
- The plan view for CASE 2 applies where the skew angle (θ) is $> 0^\circ$. The slab shown represents a skew to the right for an approach slab at begin bridge; approach slab at the end of bridge or a left skew shall be treated similarly.
- Deformed WWR must meet the requirements of Specification Section 931.
- Continue the asphalt pavement over the approach slab and match the friction course type used on the roadway.
- Approach slabs shown in Plan View Cases 1 and 2 represent a typical approach slab with edge barriers and no sidewalks. Provide railings, parapets and raised sidewalks as detailed in the Contract Plans.
- PAYMENT:** Deformed WWR for the edge of Approach Slabs on retaining walls is not included in the estimated quantity for reinforcing steel and is considered incidental to the work. See Roadway Plans for Asphalt Overlay and Optional Base details and quantities.

CROSS REFERENCES:

For Section B-B, Longitudinal Construction Joint Detail and Approach Slab Details see Sheet 2.

10/23/2018 12:16:06 PM

LAST REVISION 11/01/17	REVISION	DESCRIPTION:	 FY 2019-20 STANDARD PLANS	APPROACH SLABS (30 FT.) (FLEXIBLE PAVEMENT APPROACHES)	INDEX 400-090	SHEET 1 of 2
---------------------------	----------	--------------	----------------------------------	---	------------------	-----------------

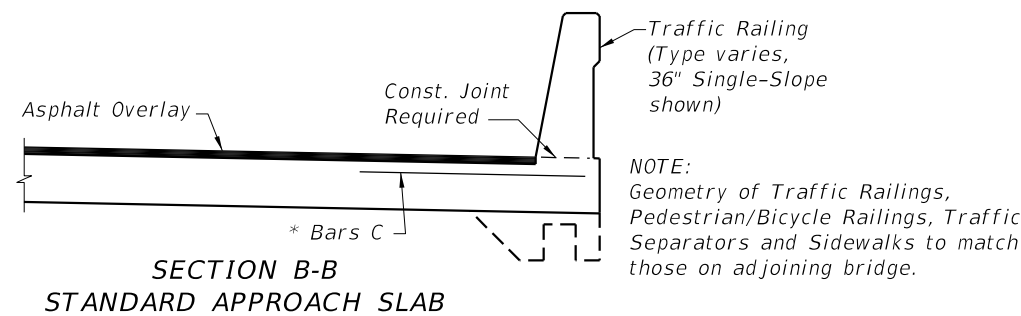

SECTION B-B
STANDARD APPROACH SLAB

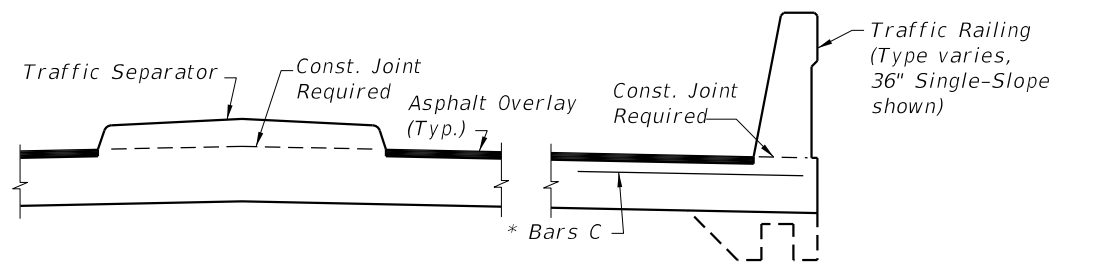

SECTION B-B
APPROACH SLAB WITH TRAFFIC SEPARATOR

*NOTE: Bars C are required as shown when the 36\"/>

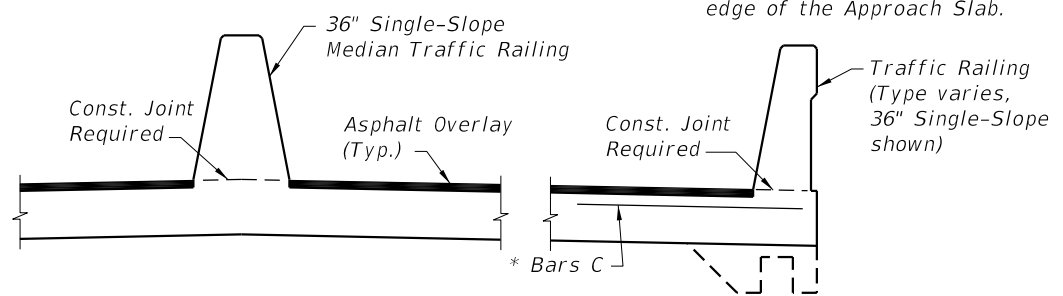

SECTION B-B
APPROACH SLAB WITH MEDIAN TRAFFIC RAILING

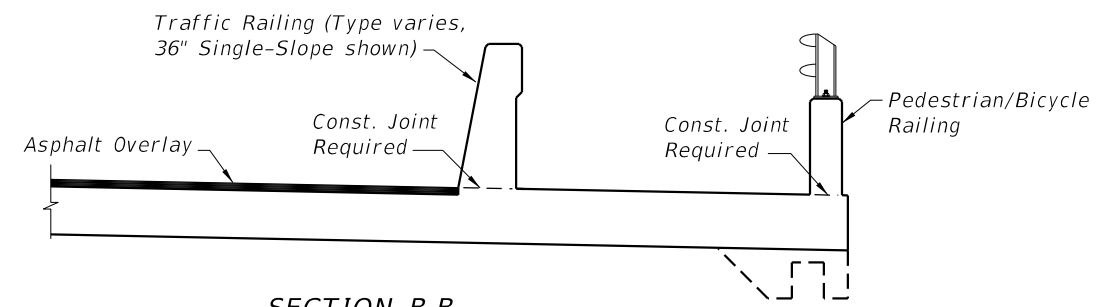

SECTION B-B
APPROACH SLAB WITH SIDEWALK

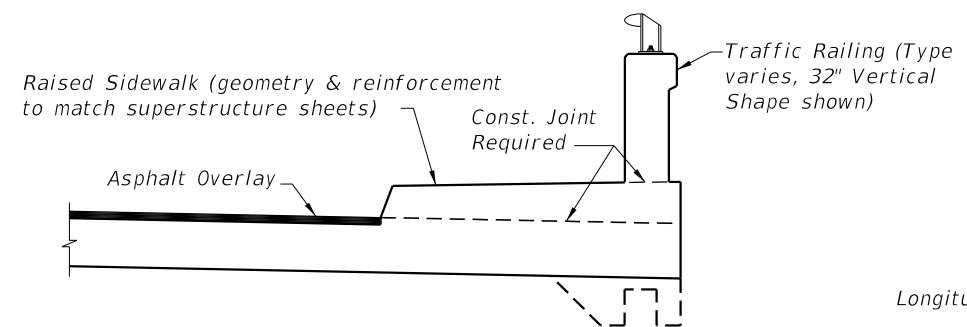

SECTION B-B
APPROACH SLAB WITH RAISED SIDEWALK

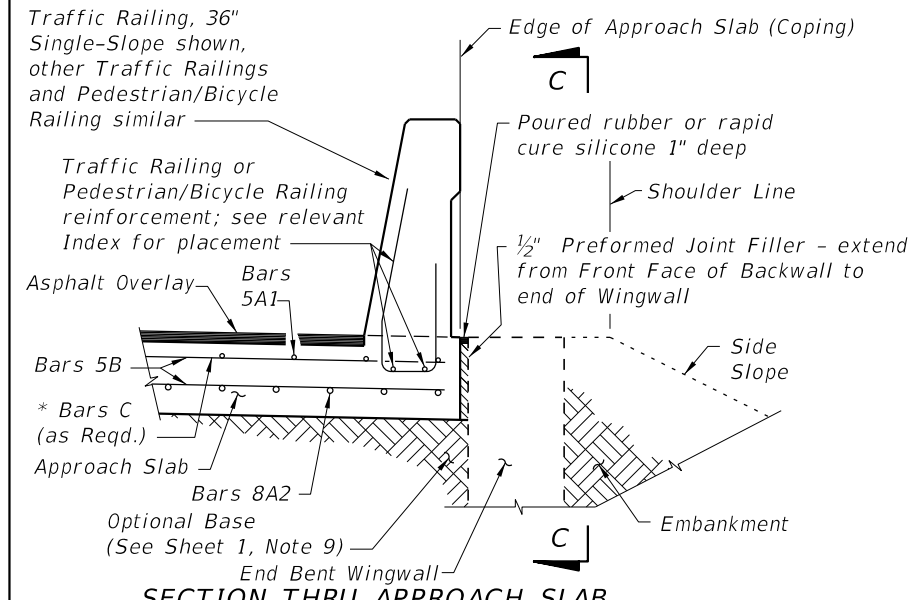

SECTION THRU APPROACH SLAB
AND END BENT WINGWALL

APPROACH SLAB WITH WINGWALL DETAILS

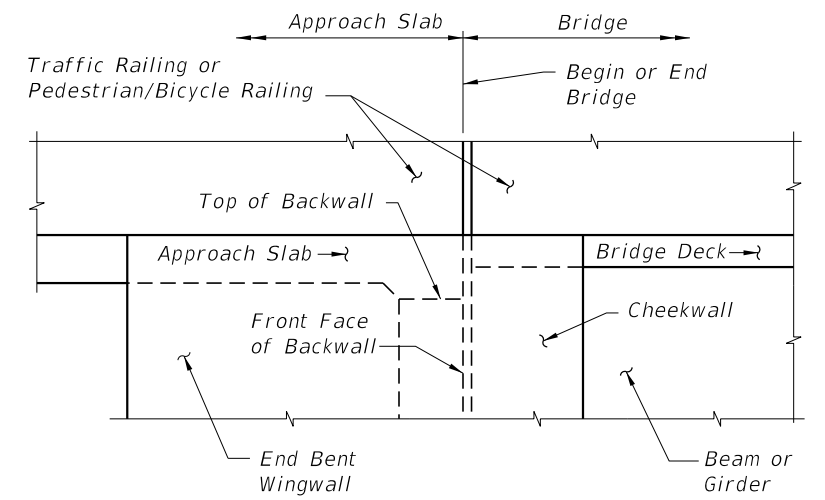

VIEW C-C AT BEGIN OR END BRIDGE (BEAM BRIDGE SHOWN, FLAT SLAB BRIDGE SIMILAR)

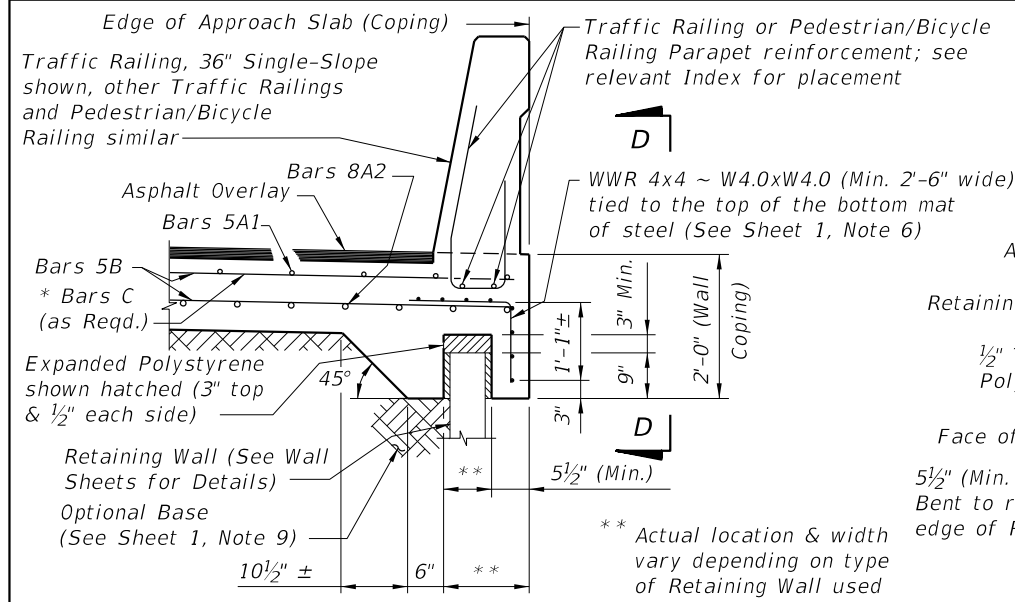

SECTION THRU APPROACH SLAB
AND RETAINING WALL

APPROACH SLAB WITH RETAINING WALL DETAILS

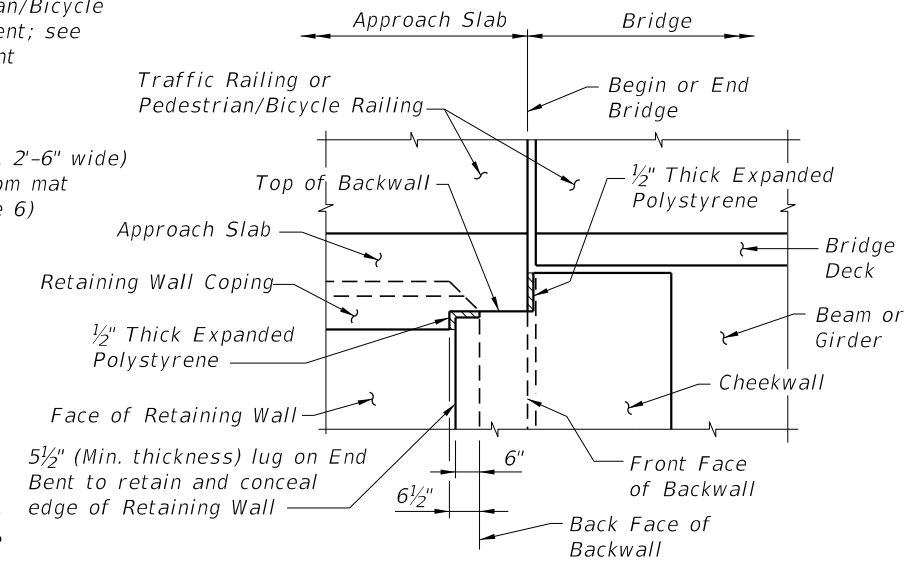

VIEW D-D AT BEGIN OR END BRIDGE (BEAM BRIDGE SHOWN, FLAT SLAB BRIDGE SIMILAR)

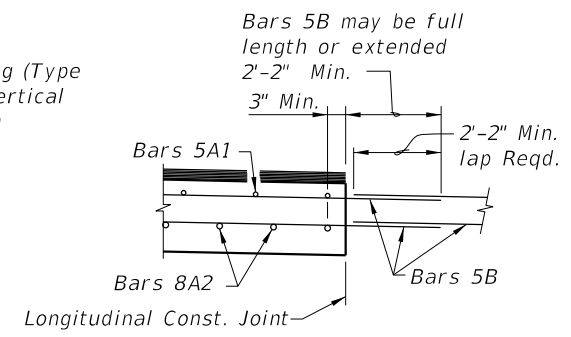

LONGITUDINAL CONSTRUCTION
JOINT DETAIL

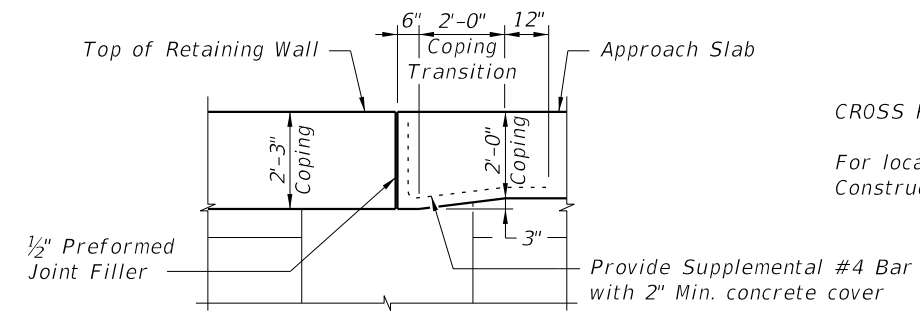

COPING TRANSITION DETAIL FOR
RETAINING WALLS WITH 2'-3\"/>

CROSS REFERENCES:
For location of Section B-B and Longitudinal Construction Joint see Sheet 1.

10/23/2018 12:16:06 PM

LAST REVISION 11/01/17	DESCRIPTION:
---------------------------	--------------