

TYPICAL CROSSOVER

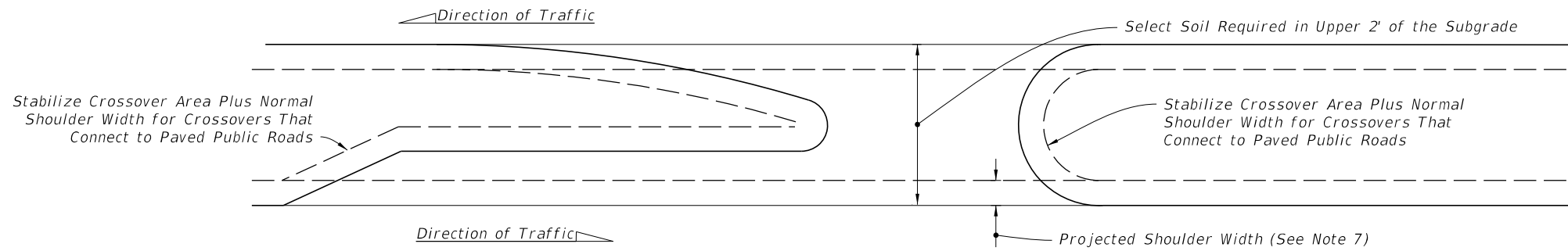

TURN LANE

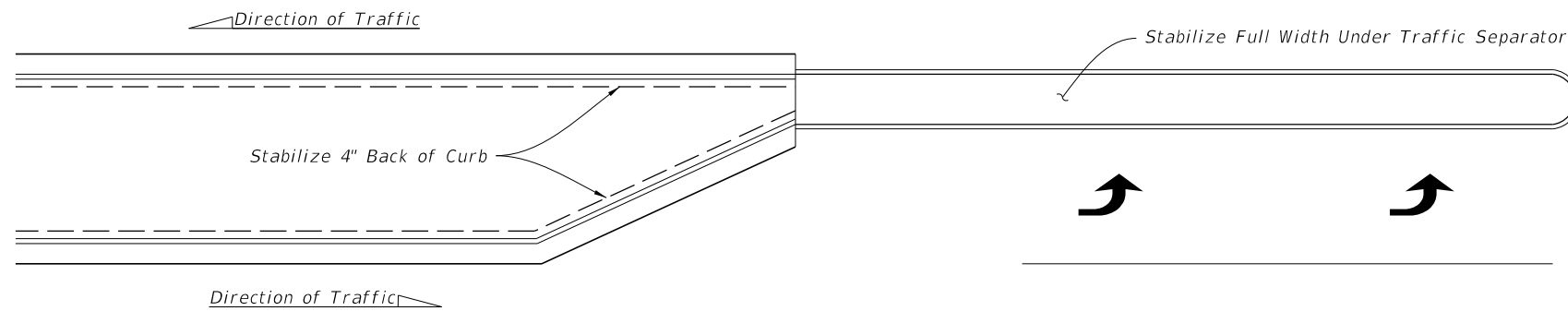

TRAFFIC SEPARATOR

NOTES:

1. When the median has curb or curb and gutter, stabilize 4" back of curb.
2. When the median has shoulder with no curb or curb and gutter, stabilize to normal shoulder width.
3. See the details above for stabilizing requirements at crossroads.
4. Stabilize entire area under all paved traffic islands.
5. Stabilize full width under all traffic separators.
6. Provide select soil where shown above and as defined on Index 120-001. For minor collectors and local facilities the depth of select material thickness may be reduced from 24" to 18".
7. Limits of Stabilization for Intermediate U-Turn Crossovers and, unless otherwise specified in the Plans, at paved and unpaved private roads and unpaved public roads.

MEDIAN STABILIZING DETAILS

8/6/2019 2:37:51 PM

LAST REVISION 11/01/18	REVISION	DESCRIPTION:	 FY 2019-20 STANDARD PLANS	MISCELLANEOUS EARTHWORK DETAILS	INDEX 160-001	SHEET 1 of 1
---------------------------	----------	--------------	---	--	-------------------------	------------------------