

**GENERAL NOTES**

1. The location and construction of mailboxes shall conform to the rules and regulations of the United States Postal Service as modified by this Index.
2. Mailboxes will not be permitted on Interstate highways, freeways, or other highways where prohibited by law or regulation.
3. The contractor shall give the Postmaster of the delivery route(s) written notice of project construction 7 days prior to the beginning of work, with Saturdays, Sundays and Holidays excluded.

The Contractor shall furnish and install one mailbox in accordance with this Index at each mail patron delivery location and maintain the box throughout the contract period. The Contractor shall apply box numbers to each patron box in accordance with identification specifications of the Domestic Mail Manual of the U. S. Postal Service; where local street names and house numbers are authorized by the Postmaster as a postal address, the Contractor shall inscribe the house number on the box; if the box is located on a different street from the patrons residence, the Contractor shall inscribe the street name and house number on the box.

The Contractor shall coordinate removal of the patrons existing mailboxes. Immediately after installing the new mailboxes the Contractor must notify each "Mail Delivery Patron" by Certified Mail that removal of the existing mailboxes must be accomplished in 21 days after receipt of notices. Patrons shall have the option of removing their existing mailboxes or leaving the mailboxes in place for removal by the Contractor; removal by the Contractor shall be included in the contract unit price for Mailbox, Each. The Contractor shall dispose of mailboxes and supports in areas provided by him.

Reuse of existing mailboxes by the Contractor will not be a requirement under any construction project; however where an existing mailbox meets the design requirements of this Index and is structurally and functionally sound, the Contractor at his option may elect to reuse the existing mailbox in lieu of constructing a new mailbox. Any use of existing mailboxes must be approved by the Engineer.

4. Mailboxes shall be light sheet metal or plastic construction, in traditional style only, and only in Size 1 as prescribed by the Domestic Mail Manual of the U. S. Postal Service (DMM).

Mailbox production standards, lists of approved manufacturers and suppliers of mailboxes, design approval and guidance may be obtained by writing to the Rural Delivery Division, Delivery Service Department, Operations Group, USPS Headquarters, Washington, DC 20260.

5. Mailboxes shall be located on the right-hand side of the roadway in the direction of the delivery route, except on one-way roads and streets where they may be placed on the left-hand side.

Mailboxes on rural highways shall be set with the roadside face of the box offset from the edge of the traveled way a minimum distance of the greater of the following:

- a. Shoulder width plus 8" to 12".
- b. 10' for ADT over 10,000 vpd.  
8' for ADT 100 to 10,000 vpd.  
6' for ADT under 100 vpd  
2'-6" for low speed and ADT under 100 vpd.

When a mailbox is installed within the limits of guardrail it should be placed behind the guardrail whenever practical.

Mailboxes on curbed highways, roads, and streets shall be set with the face of the box between 6" and 12" behind the face of curb. If the sidewalk abuts the curb or if an unusual condition exists which makes it difficult or impractical to install or serve boxes at the curb, the Contractor, with concurrence of the local postal authority, may be permitted to install all mailboxes at the back edge of the sidewalk, where they can be served by the carrier from the sidewalk.

6. Mailboxes shall be set with the bottom of the box between 42" and 48" above the mail stop surface, unless the U.S. Postal Service establishes other height restrictions.

7. No more than two mailboxes may be mounted on a support structure unless the support structure and mailbox arrangements have been shown to be safe by crash testing in accordance with NCHRP Report 350.

Neighborhood Delivery and Collection Box Units (NDCBU) are a specialized multiple mailbox installation that must be located outside the highway and street clear zones. The location of NDCBUs is the sole responsibility of the Postmaster for the delivery route under consideration.

8. Lightweight newspaper receptacles may be mounted below the mailbox on the side of the support post in conformance with the USPS Domestic Mail Manual. The mail patron shall be responsible for newspaper receptacle installation and maintenance.

9. Wood and steel support posts for both single and double mailbox mountings shall be embedded no more than 24" into the ground.

Concrete, block, brick, stone or other rigid foundation structure or encasement, either above or below the shoulder ground line, will not be permitted for mailboxes on rural highways. On urban roads and streets where mailbox support posts are set within rigid pavement back of curb, the support posts shall be separated from the pavement by a minimum of 1" of expansion material.

Support posts shall not be fitted nor installed with surface mount base plates.

10. At driveway entrances mailboxes shall be placed on the far side of the driveway in the direction of the delivery route.

At intersecting roads mailboxes shall be located 100' or more from the centerline of the intersecting road on the far side in the direction of the delivery route, with the distance increased to 200' when the route volume exceeds 400 vehicles per day.

11. Wood support posts shall be in conformance with the material and dimensional requirements of Section 952 and the treatment requirements of Section 955 of the Standard Specifications.

Steel support posts shall have an external finish equal to or better than two coats of weather resistant, air dried or baked, paint or enamel. Surface(s) shall be cleaned of all loose scale prior to finishing. The Postal Service prefers that posts be painted white, but other colors may be used when approved by the Engineer. When galvanized posts are used painting is not required.

Mounting brackets, plates, platforms, shelves and accessory hardware surface finishes are to be suited to support post finish.

12. Mailboxes shall be paid for under the contract unit price for Mailboxes, Each. Payment shall be full compensation for boxes, posts and accessory items essential for installation in accordance with this standard; erection; adjustments to suit construction needs; and, for identification letters and numbers.

Payment shall be limited to one mailbox per patron address whether the mailbox is new, reused, salvaged, reset or relocated. Payment shall be per mailbox regardless of the number of mailboxes per support or grouping arrangement.

The above compensation shall include any work and cost incurred by the contractor for removal and disposal of existing mailboxes.

There shall be no payment participation for NDCBU furnishing, assembly, installation, resetting or relocation.

9/18/2018 11:15:31 AM

LAST REVISION 11/01/17	REVISION	DESCRIPTION:		FY 2019-20 STANDARD PLANS	MAILBOXES	INDEX 110-200	SHEET 1 of 3
---------------------------	----------	--------------	--	------------------------------	-----------	------------------	-----------------

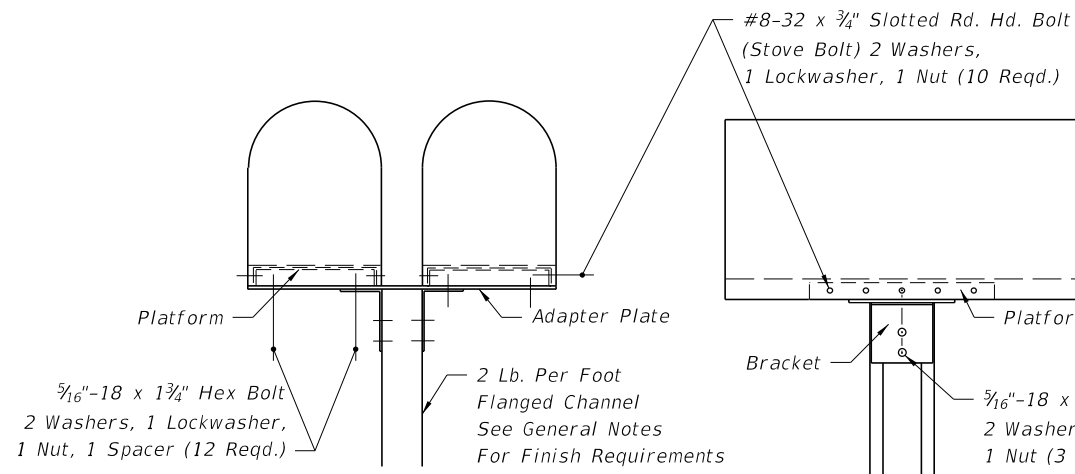

FRONT VIEW

SIDE VIEW

FLANGED CHANNEL

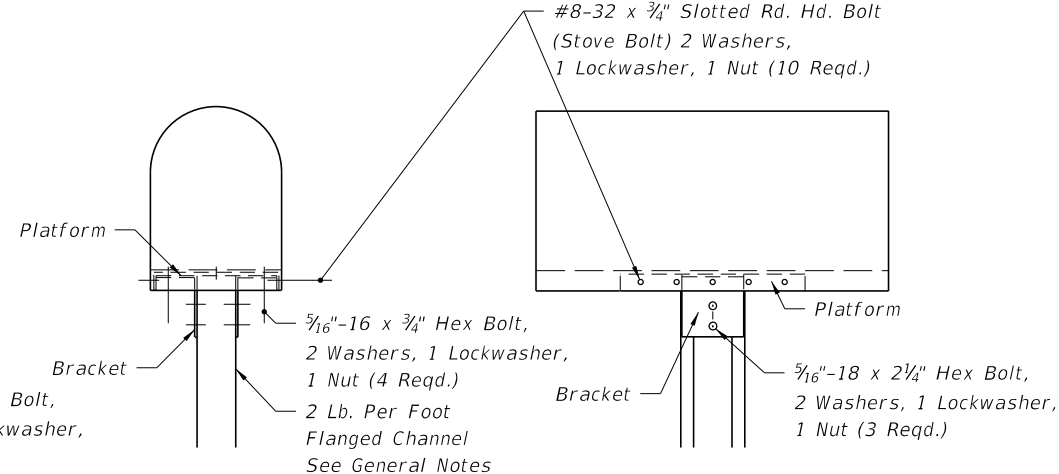

FRONT VIEW

SIDE VIEW

FLANGED CHANNEL

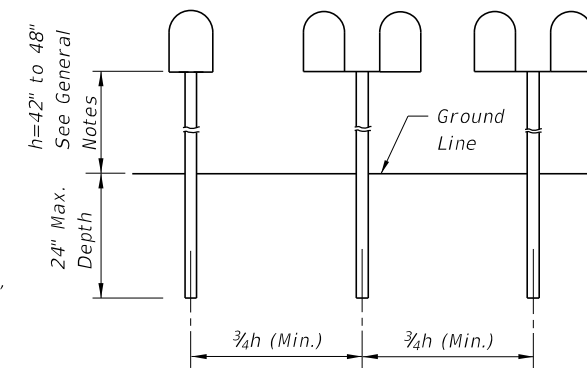

ELEVATION

SINGLE OR COMBINED WOOD, FLANGED CHANNEL OR PIPE POST TYPES SHOWN ON THIS INDEX

POST SPACING

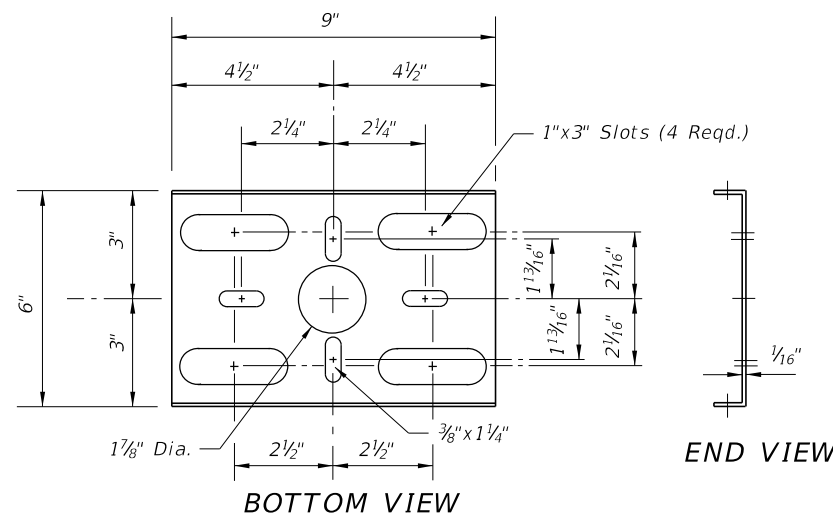

BOTTOM VIEW

END VIEW

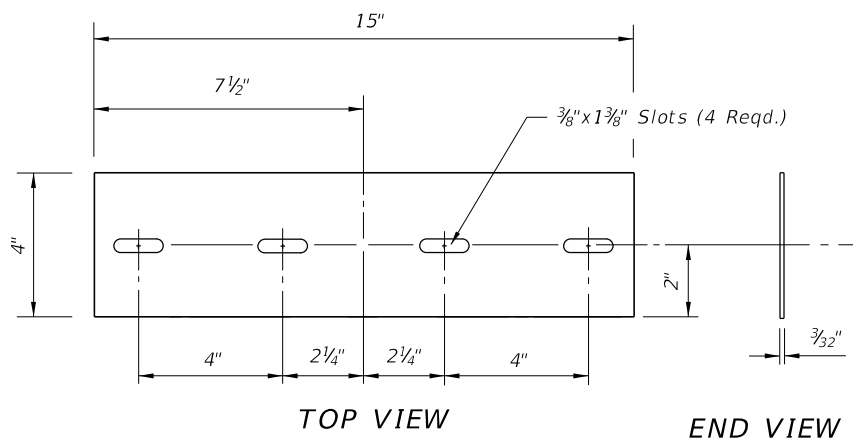

TOP VIEW

END VIEW

STEEL ADAPTER PLATE

Note: See General Notes for finish requirements.

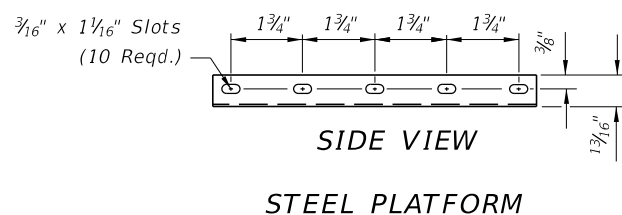

SIDE VIEW

STEEL PLATFORM

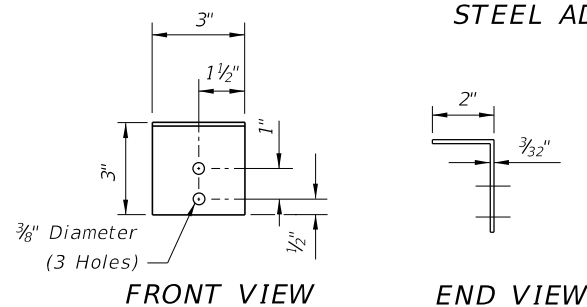

FRONT VIEW

END VIEW

TOP VIEW

STEEL BRACKET

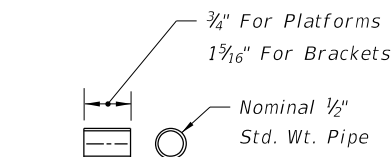

STEEL SPACER

STEEL FLANGED CHANNEL SUPPORT POSTS

9/18/2018 11:15:32 AM

LAST REVISION 11/01/17	REVISION	DESCRIPTION:	 FY 2019-20 STANDARD PLANS	MAILBOXES	INDEX 110-200	SHEET 2 of 3
---------------------------	----------	--------------	---	-----------	------------------	-----------------

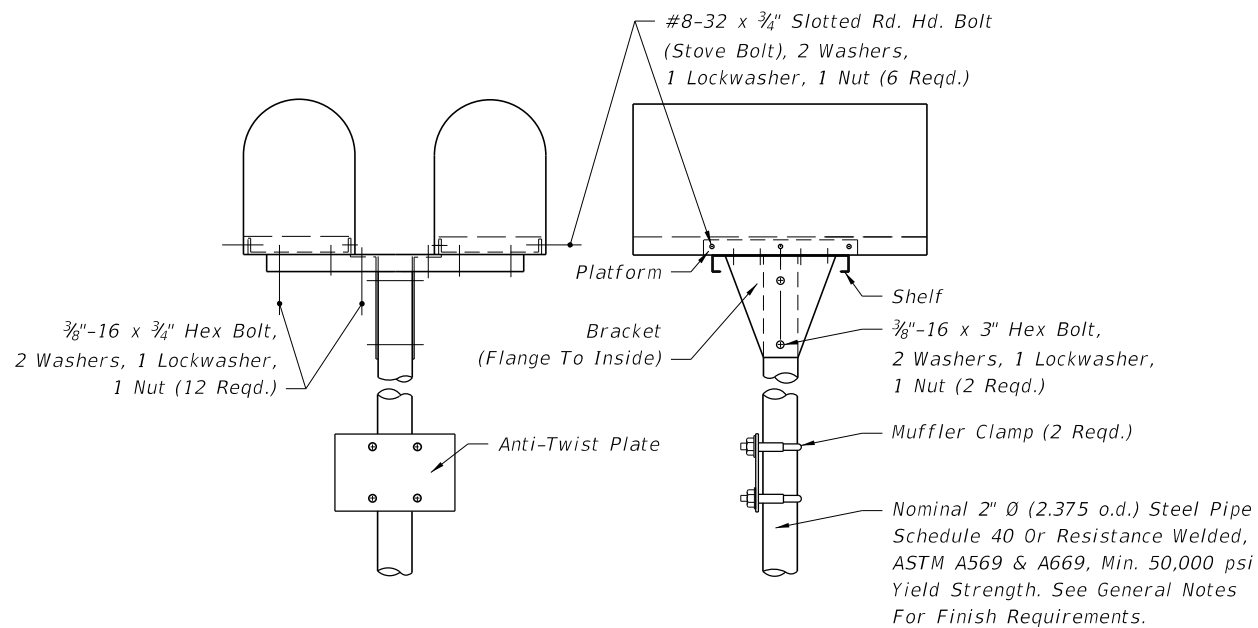

FRONT VIEW SIDE VIEW  
2" Ø PIPE POST

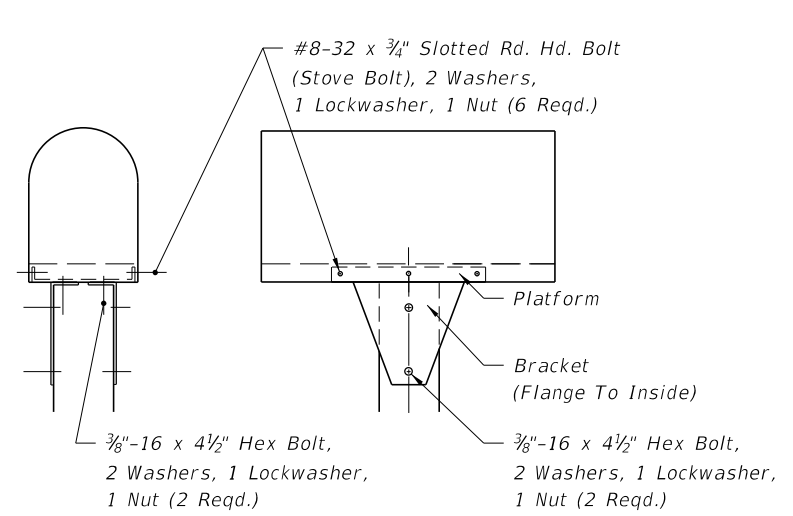

FRONT VIEW SIDE VIEW  
4" X 4" WOOD POST

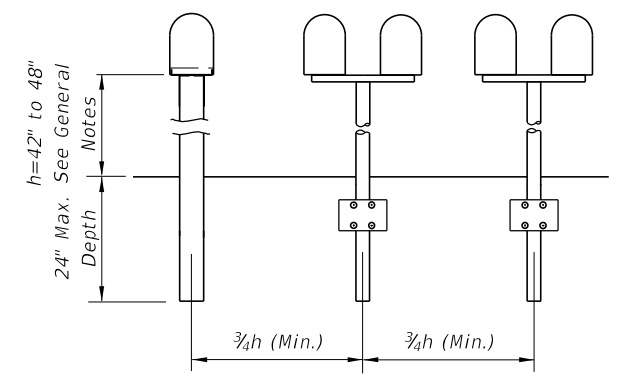

SINGLE OR COMBINED WOOD, FLANGED CHANNEL OR PIPE POST TYPES SHOWN ON THIS INDEX  
ELEVATION  
POST SPACING

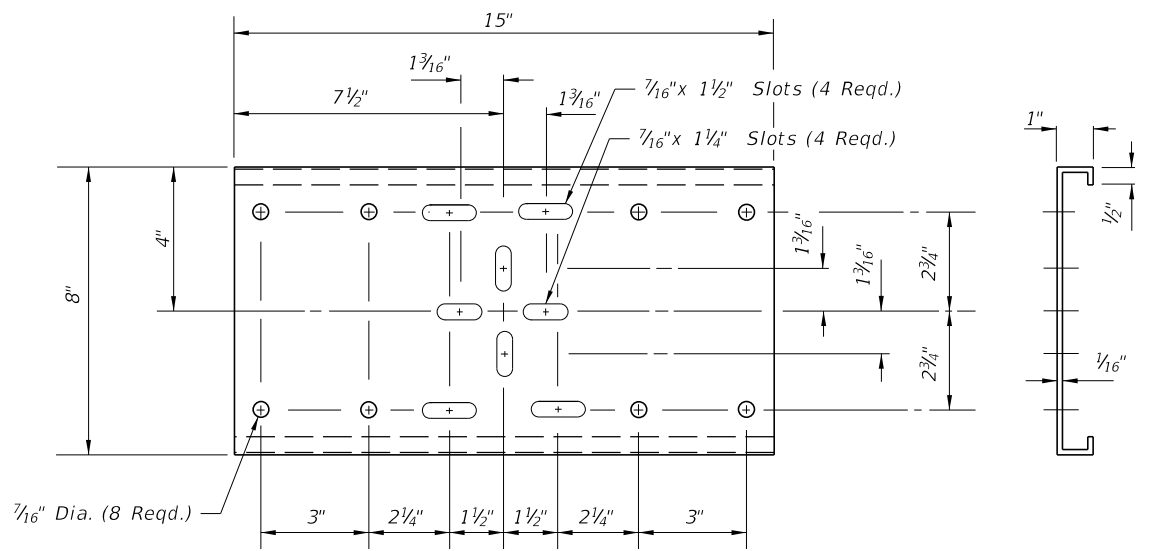

TOP VIEW END VIEW  
STEEL SHELF

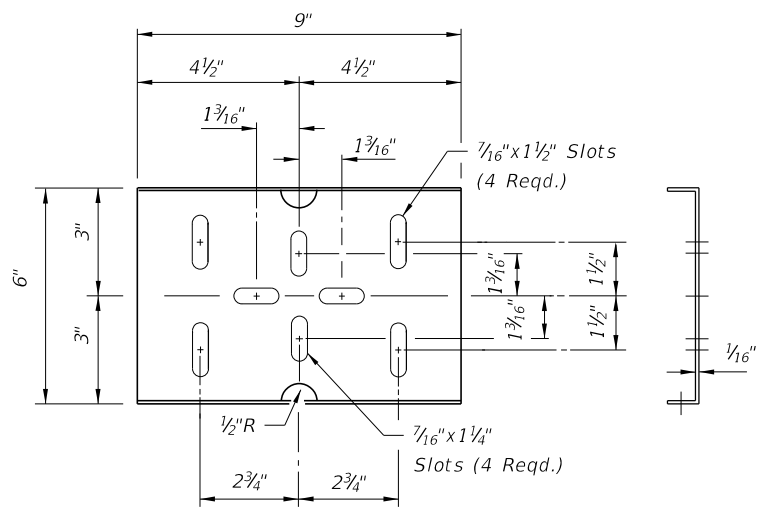

BOTTOM VIEW END VIEW  
STEEL PLATFORM

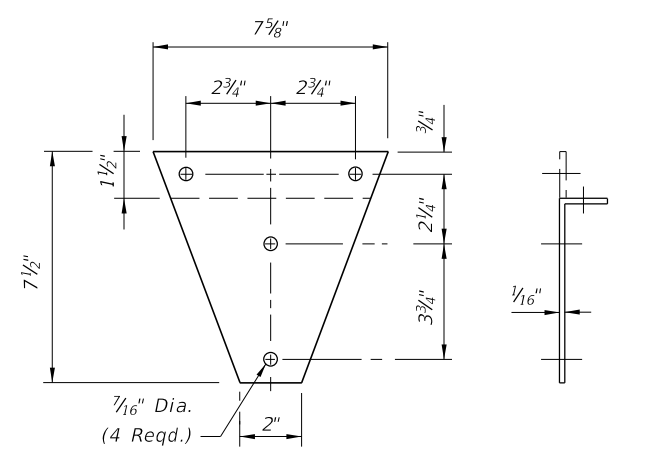

SIDE VIEW END VIEW  
STEEL BRACKET

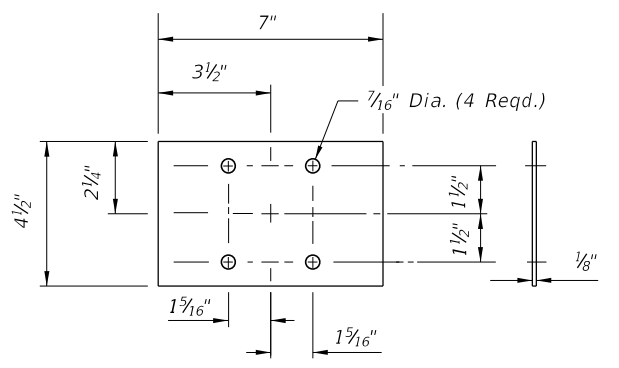

FRONT VIEW END VIEW  
STEEL ANTI-TWIST PLATE

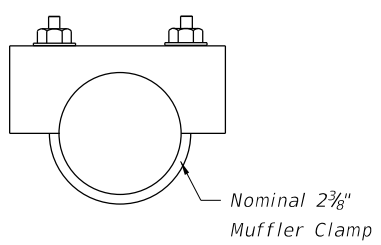

TOP VIEW  
STEEL CLAMP

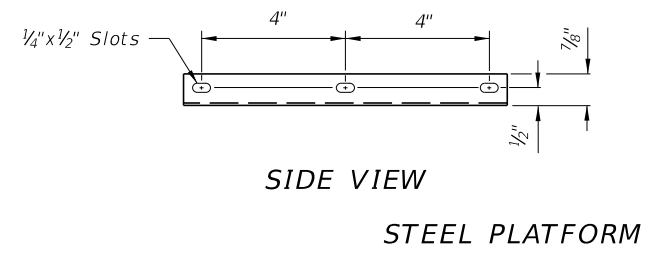

SIDE VIEW  
STEEL PLATFORM

STEEL PIPE AND WOOD SUPPORT POSTS

Note: See General Notes for finish requirements

9/18/2018 11:15:33 AM

LAST REVISION 11/01/17	DESCRIPTION:		FY 2019-20 STANDARD PLANS	MAILBOXES	INDEX 110-200	SHEET 3 of 3
REVISION						